



**N8100-1447F/1448F/1449F**  
**NEC Express5800/110Ge**  
**User's Guide**

1st Edition  
4-2008

ONL-510\_006\_01-110Ge-000-99-0803

## **PROPRIETARY NOTICE AND LIABILITY DISCLAIMER**

The information disclosed in this document, including all designs and related materials, is the valuable property of NEC Corporation (NEC) and /or its licensors. NEC and/or its licensors, as appropriate, reserve all patent, copyright and other proprietary rights to this document, including all design, manufacturing, reproduction, use, and sales rights thereto, except to the extent said rights are expressly granted to others.

The NEC product(s) discussed in this document are warranted in accordance with the terms of the Warranty Statement accompanying each product. However, actual performance of each such product is dependent upon factors such as system configuration, customer data, and operator control. Since implementation by customers of each product may vary, the suitability of specific product configurations and applications must be determined by the customer and is not warranted by NEC.

To allow for design and specification improvements, the information in this document is subject to change at any time, without notice. Reproduction of this document or portions thereof without prior written approval of NEC is prohibited.

First Printing, April 2008  
Copyright 2008  
NEC Corporation  
7-1 Shiba 5-Chome, Minato-Ku  
Tokyo 108-8001, Japan  
All Rights Reserved  
Printed in Japan

Keep this manual at hand for quick reference at anytime necessary.



## SAFETY INDICATIONS

Follow the instructions in this manual for your safety to use the NEC Express server.



Your server contains components with possible danger, hazards that may cause by ignoring warnings, and preventive actions against such hazards.

Server components with possible danger are indicated with a warning label placed on or around them as well as described in this manual.

In this manual or warning labels, "WARNING" or "CAUTION" is used to indicate a degree of danger. These terms are defined as follows:

 <b>WARNING</b>	Indicates the presence of a hazard that may result in death or serious personal injury if the instruction is ignored.
 <b>CAUTION</b>	Indicates the presence of a hazard that may cause minor personal injury, including burns, or property damage if the instruction is ignored.



Precautions and notices against hazards are presented with one of the following three symbols. The individual symbols are defined as follows:

	This symbol indicates the presence of a hazard if the instruction is ignored. An image in the symbol illustrates the hazard type. (Attention)
	This symbol indicates prohibited actions. An image in the symbol illustrates a particular prohibited action. (Prohibited Action)
	This symbol indicates mandatory actions. An image in the symbol illustrates a mandatory action to avoid a particular hazard. (Mandatory Action)

(Example)

Symbol to draw attention

Term indicating a degree of danger







 <b>CAUTION</b>	
 	<p>Plug in to a proper power source. Use a proper wall outlet of the specified voltage. Use of an improper power source may cause a fire or a power leak.</p>

Symbol indicating a prohibited action (may not always be indicated)



Description of a danger

# SYMBOLS USED IN THIS MANUAL AND WARNING LABELS



## Attentions

	Indicates that improper use may cause an electric shock.
	Indicates that improper use may cause personal injury.
 	Indicates that improper use may cause fingers to be caught.
	Indicates that improper use may cause fumes or fire.
	Indicates a general notice or warning that cannot be specifically identified.
	Indicates that improper use may cause loss of eyesight due to laser beam.

## Prohibited Actions

	Indicates a general prohibited action that cannot be specifically identified.
	Do not disassemble, repair, or modify the server. Otherwise, an electric shock or fire may be caused.

## Mandatory Action

	Unplug the power cord of the server. Otherwise, an electric shock or fire may be caused.
	Indicates a mandatory action that cannot be specifically identified. Make sure to follow the instruction.

**NOTE:** This equipment has been tested and found to comply with the limits for a Class A digital device, pursuant to Part 15 of the FCC Rules. These limits are designed to provide reasonable protection against harmful interference when the equipment is operated in a commercial environment. This equipment generates, uses, and can radiate radio frequency energy and, if not installed and used in accordance with the instruction manual, may cause harmful interference to radio communications. Operation of this equipment in a residential area is likely to cause harmful interference in which case the user will be required to correct the interference at his own expense.

### **CE Statement**

**Warning:** This is a Class A product. In domestic environment this product may cause radio interference in which case the user may be required to take adequate measures (EN55022).

### **BSMI Statement**

警告使用者：

這是甲類的資訊產品，在居住的環境中使用時，可能會造成射頻干擾，在這種情況下，使用者會被要求採取某些適當的對策。

## Trademarks

NEC ESMPRO and NEC EXPRESSBUILDER are trademarks of NEC Corporation.

Microsoft, Windows, Windows Server, and MS-DOS are registered trademarks or trademarks of Microsoft Corporation in the United States and other countries.

Intel, Pentium, and Xeon are registered trademarks of Intel Corporation.

PCI Express is a trademark of Peripheral Component Interconnect Special Interest Group.

Datalight is a registered trademark of Datalight, Inc.

ROM-DOS is a registered trademark of Datalight, Inc.

AT is a registered trademark of International Business Machines Corporation in the United States and other countries.

Adaptec and its logo is a registered trademark of Adaptec, Inc. of United States.

LSI, the LSI logo design, iBBU, MegaRAID, and WebBIOS are trademarks or registered trademarks of LSI Corporation of United States.

Adobe, Adobe logo, and Acrobat are trademarks of Adobe Systems Incorporated.

DLT and DLTtape are trademarks of Quantum Corporation of the United States.

AVOCENT and DVC (Dambrackas Video Compression) are registered trademarks or trademarks of AVOCENT in the United States and other countries.

All other product, brand, or trade names used in this publication are the trademarks or registered trademarks of their respective trademark owners.

Windows Server 2003 x64 Editions stands for Microsoft® Windows® Server 2003 R2, Standard x64 Edition Operating system and Microsoft® Windows® Server 2003 R2, Enterprise x64 Edition operating system, or Microsoft® Windows® Server 2003, Standard x64 Edition operating system and Microsoft® Windows® Server 2003, Enterprise x64 Edition operating system. Windows Server 2003 stands for Microsoft® Windows® Server 2003 R2, Standard Edition operating system and Microsoft® Windows® Server 2003 R2, Enterprise Edition operating system, or Microsoft® Windows® Server 2003, Standard Edition operating system and Microsoft® Windows® Server 2003, Enterprise Edition operating system. Windows XP x64 Edition stands for Microsoft® Windows® XP Professional x64 Edition operating system. Windows XP stands for Microsoft® Windows® XP Home Edition operating system and Microsoft® Windows® XP Professional operating system. Windows 2000 stands for Microsoft® Windows® 2000 Server operating system and Microsoft® Windows® 2000 Advanced Server operating system, and Microsoft® Windows® 2000 Professional operating system. Windows NT stands for Microsoft® Windows NT® Server network operating system version 3.51/4.0 and Microsoft® Windows NT® Workstation operating system version 3.51/4.0. Windows Me stands for Microsoft® Windows® Millennium Edition operating system. Windows 98 stands for Microsoft® Windows®98 operating system. Windows 95 stands for Microsoft® Windows®95 operating system. WinPE stands for Microsoft® Windows® Preinstallation Environment.

## Momentary voltage drop prevention:

This product may be affected by a momentary voltage drop caused by lightning. To prevent a momentary voltage drop, an AC uninterruptible power supply (UPS) unit should be used.

## Notes:

- (1) No part of this manual may be reproduced in any form without the prior written permission of NEC Corporation.
- (2) The contents of this manual may be revised without prior notice.
- (3) The contents of this manual shall not be copied or altered without the prior written permission of NEC Corporation.
- (4) All efforts have been made to ensure the accuracy of all information in this manual. If you notice any part unclear, incorrect, or omitted in this manual, contact the sales agent where you purchased this product.
- (5) NEC assumes no liability arising from the use of this product, nor any liability for incidental or consequential damages arising from the use of this manual regardless of Item (4).

## **PREFACE**

Congratulations on the purchase of your NEC Express server.

Purchase of this server is your assurance of receiving state-of-the-art, high quality hardware to meet your needs, both now and in the future.

Read this User's Guide thoroughly to fully understand handling of the NEC Express server and appreciate its functions to the maximum extent.

## ABOUT THIS USER'S GUIDE

This manual is a guide for proper setup and use of your server.

This manual also covers useful procedures for dealing with difficulties and problems that may arise during setup or operation of your server.

Keep this manual for future use.

The following describes how to proceed with this manual.

### How to Use This Manual

To aid you in finding information quickly, this manual contains the following information:

#### **Chapter 1 Notes on Using Your Server**

includes information that needs attention to use the server. Make sure to read this chapter before setting up and using the server. It also includes requirements and advisory information for transfer and disposal of the server.

#### **Chapter 2 General Description**

includes information necessary to use the server, such as names and functions of its components, handling of the optical disk drive.

#### **Chapter 3 Setting Up Your Server**

tells you how to select a site, unpack the system, make cable connections, and power on your system.

#### **Chapter 4 Configuring Your Server**

tells you how to configure the system and provides instructions for running the BIOS SETUP Utility and the RAID configuration utility, which is used to configure RAID drives in your system. This chapter also provides information on mother board jumper settings.

#### **Chapter 5 Installing the Operating System with Express Setup**

describes how to install the operating system.

#### **Chapter 6 Installing and Using Utilities**

describes how to install the utilities for the server. It also includes a description on using the attached "NEC EXPRESSBUILDER" DVD.

#### **Chapter 7 Maintenance**

provides you with all the information necessary to maintain successful operation of the server. This chapter also includes a description on relocating and storing the server.

#### **Chapter 8 Troubleshooting**

contains helpful information for solving problems that might occur with your system.

#### **Chapter 9 Upgrading Your Server**

provides you with instructions for upgrading your system with an additional processor, optional memory, optional add-in cards, hard disk drives, peripheral devices, and power supply.

#### **Chapter 10 Internal Cabling Diagram**

includes cabling information for the SATA2 controller, 5.25-inch device, and the power supply.

#### **Appendix A Specification**

provides specifications for your server.

**Appendix B Other Precautions**

provides supplementary notes on using the server.

**Appendix C IRQ**

provides a list of factory-set IRQs.

**Appendix D Installing Windows Server 2003 x64 Editions**

describes how to install Microsoft Windows Server 2003 x64 Editions without using Express Setup. Using the Express Setup tool is recommended for installing Windows Server 2003 x64 Editions. See Chapter 5 for details.

**Appendix E Installing Windows Server 2003**

describes how to install Microsoft Windows Server 2003 without using Express Setup. Using the Express Setup tool is recommended for installing Windows Server 2003. See Chapter 5 for details.

**Appendix F Using a Client Computer Which Has a CD Drive**

describes how to install the management software of EXPRESSBUILDER to the client computer without the DVD drive.

**Appendix G Product Configuration Record Table**

provides a table to be filled with your server configuration.

**Text Conventions**

The following conventions are used throughout this manual. For safety symbols, see "SAFETY INDICATIONS" provided earlier.

- |                   |   |
|-------------------|---|
| <b>IMPORTANT:</b> | Items that are mandatory or require attention when using the server |
| <b>NOTE:</b>      | Helpful and convenient piece of information                         |

**IN THE PACKAGE**

The carton contains various accessories, as well as the server itself. See the packing list to make sure that you have everything and that individual components are not damaged. If you find any component missing or damaged, contact your service representative.

- Store the provided accessories in a designated place for your convenience. You will need them to install an optional device or troubleshoot your server, as well as to set it up.
- Make a backup copy of each provided floppy disk, if any. Store the original disk as the master disk in a designated place, and use its copy.
- Improper use of any provided floppy disk or CD-ROM may alter your system environment. If you find anything unclear, immediately ask your service representative for help.

---

## CONTENTS

Preface .....	i
About This User's Guide .....	ii
In the Package .....	iii
<b>Chapter 1 Notes on Using Your Server .....</b>	<b>1-1</b>
Warning Labels .....	1-2
Safety Notes .....	1-3
General .....	1-3
Power Supply and Power Cord Use .....	1-4
Installation, Relocation, Storage, and Connection .....	1-5
Cleaning and Working with Internal Devices .....	1-6
During Operation .....	1-7
For Proper Operation .....	1-8
Transfer to Third Party .....	1-9
Disposal and Consumables .....	1-10
User Support .....	1-11
<b>Chapter 2 General Description .....</b>	<b>2-1</b>
Overview .....	2-2
System Chassis .....	2-3
Front View .....	2-3
Rear View .....	2-5
Internal View .....	2-7
Mother Board .....	2-8
Standard Features .....	2-9
Remote Power-On Feature (Wake On LAN) .....	2-10
AC LINK Feature .....	2-10
Security .....	2-10
NEC EXPRESSBUILDER .....	2-11
NEC ESMPRO .....	2-12
Maintenance Tools .....	2-12
System Diagnostic Utility .....	2-12
Remote Management .....	2-13
Using Your Server .....	2-14
POWER Switch .....	2-14
SLEEP Switch .....	2-18
Optical Disk Drive .....	2-19

<b>Chapter 3 Setting Up Your Server .....</b>	<b>3-1</b>
Setup Flow .....	3-2
UNPACKING THE SYSTEM.....	3-3
Installing Optional Devices .....	3-3
Selecting Server Site.....	3-4
Connecting Peripheral Devices.....	3-6
Connecting Power Cord.....	3-8
Turning On the Server .....	3-10
Installing Operating System .....	3-12
Installing Utilities .....	3-12
Making Backup Copies of System Information.....	3-12
<b>Chapter 4 Configuring Your Server.....</b>	<b>4-1</b>
System BIOS (BIOS Setup Utility) .....	4-2
OS Supporting Modes for Onboard SATA Controller .....	4-2
Starting SETUP Utility.....	4-3
Description on On-Screen Items and Key Usage .....	4-4
Configuration Examples.....	4-5
Menu and Parameter Descriptions .....	4-8
Configuring Mother Board Jumpers.....	4-30
RAID System Configuration .....	4-32
RAID.....	4-32
Configuration by Onboard RAID Controller .....	4-37
Setup Utility .....	4-39
LSI Software RAID Configuration Utility and Universal RAID Utility.....	4-52
<b>Chapter 5 Installing the Operating System with Express Setup.....</b>	<b>5-1</b>
About Express Setup .....	5-2
Microsoft Windows Server 2003 .....	5-3
Notes on Windows Installation.....	5-3
Flow of Setup .....	5-9
Installing the Windows Server 2003.....	5-10
Installing and Setting Device Drivers.....	5-19
Setting for Solving Problems .....	5-27
Installing Maintenance Utilities .....	5-32
Updating the System – Installing Service Pack –.....	5-32
Making Backup Copies of System Information .....	5-33
Installing with the OEM-FD for Mass Storage Device .....	5-34
<b>Chapter 6 Installing and Using Utilities .....</b>	<b>6-1</b>
NEC EXPRESSBUILDER.....	6-2
Autorun Menu .....	6-6
Parameter File Creator.....	6-7
Parameter File .....	6-8
NEC ESMPRO .....	6-18
Functions and Features.....	6-18

---

Universal RAID Utility.....	6-19
Setup with Express Setup.....	6-19
Manual Setup.....	6-19
Using Universal RAID Utility via Network.....	6-20
Easy Configuration.....	6-20
Creating Logical Drive of RAID 6.....	6-20
<b>Chapter 7 Maintenance.....</b>	<b>7-1</b>
Making Backup Copies.....	7-1
Cleaning.....	7-2
Cleaning the Server.....	7-3
Cleaning the Interior.....	7-4
Cleaning the Keyboard/Mouse.....	7-5
Cleaning Disc.....	7-6
System Diagnostics.....	7-7
Test Items.....	7-7
Startup and Exit of System Diagnostics.....	7-7
Relocating/Storing The Server.....	7-10
<b>Chapter 8 Troubleshooting.....</b>	<b>8-1</b>
System Viewers.....	8-2
Lamps.....	8-3
POWER/SLEEP Lamp.....	8-4
DISK ACCESS Lamp.....	8-4
LINK/ACT Lamp.....	8-4
1000/100/10 Lamp.....	8-4
Error Messages.....	8-5
Error Messages after Power-on.....	8-5
POST Error Messages.....	8-6
Beep Codes.....	8-8
Solving Problems.....	8-9
Problems with NEC Express Server.....	8-9
Problems with Windows.....	8-14
Problems with NEC EXPRESSBUILDER.....	8-18
Problems with Express Setup.....	8-19
Problems with RAID System Configuration.....	8-20
Problems with Windows Autorun Menu.....	8-22
Collecting Event Log.....	8-23
Collect Configuration Information.....	8-24
Collecting Dr. Watson Diagnostic Information.....	8-25
Memory Dump.....	8-25
Recovery for Windows Server 2003 x64 Editions and Windows Server 2003.....	8-26
Maintenance Tools.....	8-27
Starting Maintenance Tools.....	8-27
Function of Maintenance Tools.....	8-29
Resetting the Server.....	8-31
Forced Shutdown.....	8-32

<b>Chapter 9 Upgrading Your Server .....</b>	<b>9-1</b>
Safety Notes.....	9-2
Static Precautions .....	9-3
Preparing for Installation and Removal.....	9-4
Installation or Removal Procedure .....	9-5
Left Side Cover .....	9-5
Front Mask .....	9-9
3.5-inch Hard Disk Drive .....	9-11
PCI Board.....	9-23
DIMM .....	9-31
File Device .....	9-37
Floppy Disk Drive.....	9-43
<b>Chapter 10 Internal Cabling Diagrams.....</b>	<b>10-1</b>
Interface Cables .....	10-2
Addition of Hard Disk Drive.....	10-2
Connection of 5.25-inch Device.....	10-6
Power Cables .....	10-9
<b>Appendix A Specifications.....</b>	<b>A-1</b>
<b>Appendix B Other Precautions.....</b>	<b>B-1</b>
Transfer Rate of the On-board LAN Controller .....	B-1
Server Management Software .....	B-1
Floppy Disk.....	B-1
DVD/CD-ROM .....	B-4
Tape Media.....	B-4
Keyboard.....	B-5
Mouse.....	B-6
<b>Appendix C IRQ.....</b>	<b>C-1</b>
<b>Appendix D Installing Windows Server 2003 x64 Editions.....</b>	<b>D-1</b>
Before Installing Windows Server 2003 x64 Editions.....	D-1
Optional Board Supported by NEC EXPRESSBUILDER.....	D-1
Service Pack Which EXPRESSBUILDER Supports .....	D-2
Installing Service Pack.....	D-2
Updating System .....	D-2
Re-installing to the Hard Disk Drive which has been upgraded to Dynamic Disk .....	D-2
Mounting MO Device .....	D-2
About Removable Media .....	D-2
About the System Partition Size.....	D-3
Installing Windows Server 2003 x64 Editions.....	D-4
Creating "Windows Server 2003 x64 Edition OEM-Disk for EXPRESSBUILDER" .....	D-5
Windows Server 2003 x64 Editions Clean Installation .....	D-7
Reinstallation to Multiple Logical Drives .....	D-10
Procedure for License Authentication .....	D-11
Updating the System - Applying Service Pack - .....	D-12

Driver Installation and Advanced Settings .....	D-17
PROSet.....	D-17
Adapter Fault Tolerance (AFT)/Adaptive Load Balancing (ALB).....	D-19
Network Driver .....	D-21
Re-install the Network Driver .....	D-22
Optional Network Board Driver.....	D-23
Installation of the Optional Network Board Driver.....	D-23
Graphics Accelerator Driver.....	D-24
Installing SCSI Controller Driver (N8103-75/107).....	D-24
Installing SCSI Controller Driver (N8103-95).....	D-24
About Windows Activation .....	D-25
Setting for Collecting Memory Dump (Debug Information).....	D-26
<b>Appendix E Installing Windows Server 2003 .....</b>	<b>E-1</b>
Before Installing Windows Server 2003 .....	E-1
Optional Board Supported by NEC EXPRESSBUILDER.....	E-1
Service Pack Which EXPRESSBUILDER Supports .....	E-2
Installing Service Pack .....	E-2
Updating System .....	E-2
Re-installing to the Hard Disk Drive which has been upgraded to Dynamic Disk .....	E-2
Mounting MO Device .....	E-3
About Removable Media .....	E-3
About the Upgrade to Windows Server 2003 R2 .....	E-3
About the System Partition Size.....	E-4
Installing Windows Server 2003.....	E-5
Creating "Windows Server 2003 OEM-Disk for EXPRESSBUILDER" .....	E-6
Windows Server 2003 Clean Installation .....	E-8
Reinstallation to Multiple Logical Drives .....	E-11
Re-installing the Operation System if Multiple Logical Drives Exist.....	E-13
Procedure for License Authentication .....	E-14
Updating the System - Applying Service Pack - .....	E-14
Driver Installation and Advanced Settings .....	E-20
PROSet.....	E-20
Network Driver .....	E-21
Re-install the Network Driver .....	E-22
Adapter Fault Tolerance (AFT)/Adaptive Load Balancing (ALB).....	E-22
Graphics Accelerator Driver.....	E-22
Installing SCSI Controller Driver (N8103-75/95/107).....	E-23
About Windows Activation .....	E-23
Setting for Collecting Memory Dump (Debug Information).....	E-24
<b>Appendix F Using a Client Computer Which Has a CD Drive .....</b>	<b>F-1</b>
<b>Appendix G Product Configuration Record Table.....</b>	<b>G-1</b>
Hardware.....	G-1
Software .....	G-3

# Chapter 1

---

## Notes on Using Your Server

This chapter includes information necessary for proper and safe operation of your server.

## WARNING LABELS

The warning label is attached to components with possible danger or their vicinity in your server to inform the user that a hazardous situation may arise when operating the server. (Do not intentionally remove or damage any of the labels.)

If you find any labels totally/partially removed or illegible due to damage, contact your sales representative.

**重畳物注意**  
**注意重畳**  
**注意重畳**  
**WARNING:**  
**HEAVY ITEM**



ぎっくり腰や落下事故防止のため移動のさいは2人以上で行って下さい。  
为了防止腰肌受损以及物体失手落下, 移动设备时请一定由2个人以上进行。  
為了防止腰部受傷以及設備掉落, 移動伺服器時請由2人以上進行。



**To avoid the risk of personal injury or damage to the unit, move the unit with at least two or more people.**

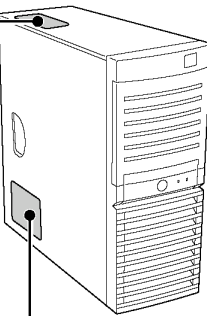

**⚠ 注意 CAUTION**

オプションの取付け、取外し時は電源プラグをコンセントから抜き、外部装置と接続しているケーブルを外して下さい。  
进行可选配件的安装和拆卸时, 请先把电源插头从插座中拔出, 并取下与外部设备连接着的线缆。  
進行選購設備的安裝和拆卸時, 請先把電源插頭從插座中拔出, 並取下與外部設備連接的線纜。

Disconnect all AC power cords from both system and external peripherals prior to installing/removing options.

 電源プラグを抜く  
感電注意  
抜下電源插头  
有触电危险  
拔掉电源插頭  
注意觸電

ネジは本体内部へ落とさない様、十分ご注意ください。  
请一定注意不要把螺丝掉落在主机内部。  
請注意絕對不要將螺絲掉入設備內部。  
Do not drop any screws inside the system.

ボード及びオプション機器の接続の際は、必ずユーザースタンドを参照し、正しく接続して下さい。  
誤った接続は、故障や火災の原因となります。  
对板卡以及可选设备进行连接时, 请务必参照“用户指南”, 正确进行连接。  
如果错误连接, 可能会导致故障或火灾的发生。  
安裝控制卡及選購設備時, 請務必參照“用戶指南”, 進行正確連接。  
連接錯誤時, 可能會造成故障或火災。

Refer to the "User's Guide" when option board or peripherals are installed. Incorrect installations may result in damage to the system and lead to accidents.

指をはさんだり、ぶつけたりしないように注意して下さい。  
请小心不要夹住或碰伤手指。  
請注意不要夾傷手指, 或因碰撞而受傷。  
To avoid the risk of personal injury, be careful when accessing the inside of the system.

装置の持ち上げ、移動の際は、装置の底面をしっかり持って持ち上げて下さい。  
抬起或移动设备时, 请注意托稳设备底部。  
抬起或搬運伺服器時, 請牢牢托住設備底部進行搬運。  
Firmly hold the bottom of the system when required to lift and carry the system.

## SAFETY NOTES

This section provides notes on using your server safely. Read this section carefully to ensure proper and safe use of the server. For symbols, see "SAFETY INDICATIONS" provided earlier.

### General

#### WARNING



Do not use the server for services where critical high availability may directly affect human lives.

Your server is not intended to be used with or control facilities or devices concerning human lives, including medical devices, nuclear facilities and devices, aeronautics and space devices, transportation facilities and devices; and facilities and devices requiring high reliability. NEC assumes no liability for any accident resulting in personal injury, death, or property damage if the server has been used in the above conditions.



Do not use the server if any smoke, odor, or noise is present.



If smoke, odor, or noise is present, immediately turn off the server and disconnect the power plug from the outlet, then contact your service representative. Using the server in such conditions may cause a fire.



Keep needles or metal objects away from the server.

Do not insert needles or metal objects into ventilation holes in the server or openings in the floppy disk or optical disk drive. Doing so may cause an electric shock.

#### CAUTION



Keep water or foreign matter away from the server.



Do not let any form of liquid (water etc.) or foreign matter (e.g., pins or paper clips) enter the server. Failure to follow this warning may cause an electric shock, a fire, or a failure of the server. When such things accidentally enter the server, immediately turn off the power and disconnect the power plug from the outlet. Do not disassemble the server. Contact your service representative.

## Power Supply and Power Cord Use

### WARNING



Do not hold the power plug with a wet hand.

Do not disconnect/connect the plug while your hands are wet. Failure to follow this warning may cause an electric shock.

### CAUTION



Plug in to a proper power source.

Use a proper wall outlet of the specified voltage. Use of an improper power source may cause a fire or a power leak.



Do not install the server where you need an extension cord. Use of a cord that does not meet the power specifications of your server may heat up the cord and cause a fire.



Do not connect the power cord to an outlet that has an illegal number of connections.

The electric current exceeding the rated flow overheats the outlet, which may cause a fire.



Do not pull the cable when disconnecting it.



When disconnecting the cable from the device, hold the cable connector and pull it straight out. Pulling the cable out by the cable portion or giving mechanical stress to the connector could damage the cables and connectors to result in an electrical shock hazard or a fire.



Insert the power plug into the outlet as far as it goes.

Heat generation resulting from a halfway inserted power plug (imperfect contact) may cause a fire. Heat will also be generated if condensation is formed on dusty blades of the halfway inserted plug, increasing the possibility of fire.



Use the authorized power cord only.



Use only the power cord that comes with your server. Use of an unauthorized power cord may cause a fire when the electric current exceeds the rated flow. Also, observe the following to prevent an electric shock or fire caused by a damaged cord.

- Do not stretch the cord harness.
- Do not pinch the power cord.
- Do not bend the power cord.
- Keep chemicals away from the power cord.
- Do not twist the power cord.
- Do not place any object on the power cord.
- Do not bundle power cords.
- Do not alter, modify, or repair the power cord.
- Do not secure the power cord with staples or equivalents.
- Do not use any damaged power cord. (Replace a damaged power cord with a new one of the same specifications. Ask your service representative for replacement.)

## Installation, Relocation, Storage, and Connection

### WARNING



Disconnect the power cord(s) before installing or removing the server.

Make sure to power off the server and disconnect the power cord(s) from a power outlet before installing/removing the server. All voltage is removed only when the power cords are unplugged.

### CAUTION



Never attempt to lift the server only by yourself.

Your server weighs max 18 kg (depending on its hardware configuration). Carrying the server only by yourself may strain your back. Hold the server firmly by its bottom with at least two or more people. Do not hold the front mask to lift the server. The front mask may be disengaged from the server, causing personal injury.



Do not install the server in any place other than specified.

Do not install the server in the following places or any place other than specified in this manual. Failure to follow this instruction may cause a fire.

- a dusty place
- a humid place such as near a boiler
- a place exposed to direct sunlight
- an unstable place



Do not connect any interface cable with the power cord of the server plugged to a power source.



Make sure to power off the server and unplug the power cord from a power outlet before installing/removing any optional internal device or connecting/disconnecting any interface cable to/from the server. If the server is off-powered but its power cord is plugged to a power source, touching an internal device, cable, or connector may cause an electric shock or a fire resulted from a short circuit.



Do not use any unauthorized interface cable.

Use only interface cables provided by NEC and locate a proper device and connector before connecting a cable. Using an authorized cable or connecting a cable to an improper destination may cause a short circuit, resulting in a fire. Also, observe the following notes on using and connecting an interface cable.

- Do not use any damaged cable connector.
- Do not step on the cable.
- Do not place any object on the cable.
- Do not use the server with loose cable connections.

## Cleaning and Working with Internal Devices

### WARNING



Do not disassemble, repair, or alter the server.



Never attempt to disassemble, repair, or alter the server on any occasion other than described in this manual. Failure to follow this instruction may cause an electric shock or fire as well as malfunctions of the server.



Do not look into the optical disk drive.



A laser beam used in the optical disk drive is harmful to the eyes. Do not look into or insert a mirror into the drive while the drive is powered. If a laser beam is caught in your eyes, you may lose your eyesight (the laser beam is invisible).



Do not remove the lithium battery.

Your server contains the lithium battery. Do not remove the battery. Placing the lithium close to a fire or in the water may cause an explosion.

When the server does not operate appropriately due to the dead lithium battery, contact your service representative. Do not disassemble the server to replace or recharge the battery by yourself.



Disconnect the power plug before accessing inside the server, or connecting the peripherals.



Make sure to power off the server and disconnect the power plug from a power outlet before cleaning or installing/removing internal optional devices. Touching any internal device of the server with its power cord connected to a power source may cause an electric shock even if the server is off-powered.

Disconnect the power plug from the outlet occasionally and clean the plug with a dry cloth. Heat will be generated if condensation is formed on a dusty plug, which may cause a fire.

### CAUTION



Avoid installation in extreme temperature conditions.

Immediately after the server is powered off, its internal components such as hard disk drives are very hot. Leave the server until its internal components fully cool down before installing/removing any component.



Make sure to complete board installation.

Always install a board firmly. An incompletely installed board may cause a contact failure, resulting in smoking or fire.



Protect the unused connectors with the protective cap.

The unused power supply cable connectors are covered with the protective cap to prevent short circuits and electrical hazards, when removing the power supply cable connector from the installed devices, attach the protective cap to the connector. Failure to follow this warning may cause a fire or an electric shock.

---

## During Operation

**⚠ CAUTION**

Stay away from the fan.

Keep your hand or hair away from the cooling fan on the rear of the server. Failure to follow this warning may get your hand or hair caught in the fan, resulting in injury.



Avoid contact with the server during thunderstorms.



Disconnect the power plug from the outlet when a thunderstorm is approaching. If it starts thundering before you disconnect the power plug, do not touch any part of the server including the cables. Failure to follow this warning may cause a fire or an electric shock.



Keep animals away from the server.



Failure to follow this warning may cause a fire or an electric shock.



Do not leave the CD tray open.

If dust gets on the lens of optical disk drive, the drive may have problems reading your disks. Also, the CD tray may be broken by contacting any objects.



Take off the headset before connection.

To protect your ears, take off the headset before connecting it to the headset jack. Make sure that the volume is not extremely turned up before connection.



Do not place any object on top of the server.

The server may fall and cause property damage to the surroundings.

## FOR PROPER OPERATION

Observe the following notes for successful operation of the server. Use of the server ignoring the notes will cause malfunctions or failures of the server.

- Install the server in a place that meets requirements for successful operation. For details, see Chapter 3, "Setting Up Your Server."
- If the power cord supplied with your system is not compatible with the AC wall outlet in your region, contact your service representative to obtain a suitable power cord.
- Make sure to power off the server before connecting or disconnecting cables between the server and peripheral devices.
- Verify that the access lamp on the server is unlit before turning off the server or ejecting the floppy disk.
- When plugging the power cord to the system, you may experience 10 seconds delay from the time you press the POWER/SLEEP switch on the front panel. This is normal system operation.
- When you have just turned off the server, wait at least 10 seconds before turning it back on. If the server is connected to the UPS, set at least 10 seconds delay in the power-on schedule.
- For the disk which does not conform to the CD standard, the playback of such a disk with the CD drive is not guaranteed.
- Turn off the power and unplug the power cord from the outlet before relocating the server.
- Clean the server on a regular basis. (See Chapter 7 for cleaning.) Regular cleaning proactively prevents various failures of the server.
- Lightning may cause a momentary voltage drop. To prevent this problem, it is recommended to use of an uninterruptible power supply unit.
- Make sure to use optional devices supported by the server. Some non-supported devices may be physically installed/connected but cause failures of the server as well as malfunctions of the server.
- NEC recommends you use NEC's genuine products. Some third-party products claim that they support the server. However, repair of the server due to a failure or damage resulted from use of such third-party products will be charged.
- Turn off the cellular phone or pager. Radio interference may cause malfunctions of the server.

## TRANSFER TO THIRD PARTY

The following must be observed when you transfer (or sell) the server or software provided with the server to a third party:

Make sure to provide this manual along with the server to a third party.

---

**IMPORTANT:** About data on the hard disk drive

Be sure to take appropriate measures not to leak important data (e.g., customers' information or companies' management information) on the removed hard disk drive to any third parties.

Data seems to be erased when you empty "Recycle Bin" of Windows or execute the "format" command of the operating system. However, the actual data remains written on the hard disk drive. Data not erased completely may be restored by special software and used for unexpected purposes.

It is strongly recommended that the software or service (both available at stores) for data erasure should be used in order to avoid the trouble explained above. For details on data erasure, ask your sales representative.

---

### Provided software

To transfer or sell any software application that comes with the server to a third party, the following requirements must be satisfied:

- All provided software applications must be transferred and no backup copies must be retained.
- Transfer requirements listed in "Software License Agreement" that comes with each software application must be satisfied.
- Software applications that are not approved for transfer must be uninstalled before transferring the server.

## DISPOSAL AND CONSUMABLES

- Dispose of the server, all the internal devices, floppy disks, and CD-ROMs according to all national laws and regulations.

### IMPORTANT:

- For disposal (or replacement) of the battery on the mother board of the server, consult with your service representative.
  - It is the user's responsibility to completely erase or modify all the data stored in storage device such as hard disk drive so that the data cannot be restored.
- 
- Your server contains some components that are only good for a limited period of time and require replacement, such as fans, internal batteries, the internal optical disk drive, the floppy disk drive, and the mouse. For stable operation of the server, NEC recommends you replace these components on a regular basis. Consult with your service representative for replacement or the product lives.

**⚠ WARNING**



Do not remove the lithium battery.

Your server contains the lithium battery. Do not remove the battery. Placing the lithium or nickel cadmium battery close to a fire or in the water may cause an explosion.

When the server does not operate appropriately due to the dead lithium battery, contact your service representative. Do not disassemble the server to replace or recharge the battery by yourself.

**CAUTION:** Risk of explosion if battery is replaced with an incorrect type. Dispose of used batteries according to the instructions.

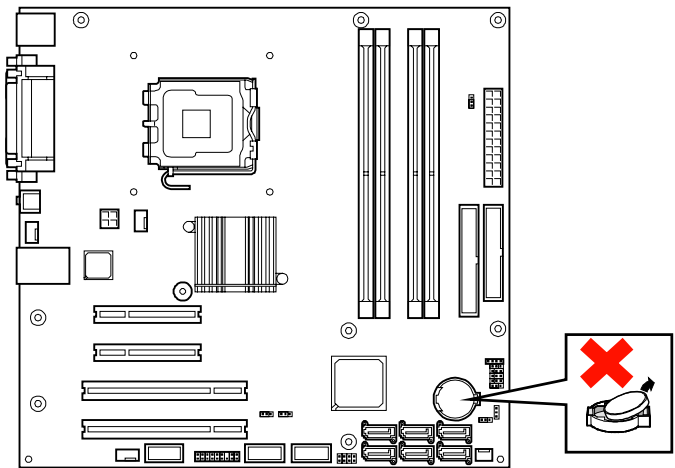

**Mother board**

## USER SUPPORT

Before Asking for Repair, do the following when the server appears to fail:

1. Check if the power cord and the cables to other devices are properly connected.
2. See Chapter 8 to find if your problem fits the description. If it does, take the recommended measure for it.
3. Check if the software required for operation of the server is properly installed.

If the server still appears to fail after you have taken the above actions, consult with your service representative immediately. Take notes on lamp indications of the server and alarm indications on the display unit before consultation, which may provide a significant help to your service representative.

## Advice for Health

The longer you keep using the computer equipment, the more you become tired, which may cause disorders of your body. When you use a computer, observe the following to keep yourself from getting tired:

### Good Working Posture

You have good posture if the following are satisfied when you use a computer:

- You sit on a chair with your back straight.
- Your hands are parallel with the floor when you put them on the keyboard.
- You look at the screen slightly lower than your eye height.



You have "good working posture" as described in the above when no part of your body is under excess strain, in other words when your muscles are most relaxed.

You have "bad posture" when you sit with your back hunched up or you operate a display unit with your face close to the screen. Bad working posture may cause eye strain or poor eyesight.

### Adjustment of Display Unit Angles

Most display units are designed for adjustment of the horizontal and vertical angles. This adjustment is important to prevent the screen from reflecting bright lights and to make the display contents easy to see. You will not be able to keep "good working posture" and you will feel more tired than you should if you operate a display unit without adjusting horizontal and vertical angles.

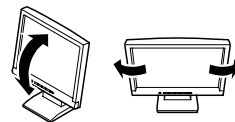

### Adjustment of Screen Brightness and Contrast

The display unit has brightness and contrast adjustment functions. The most suitable brightness and contrast depend on the individual and the working environment (well-lighted room or insufficient light). Adjust brightness and contrast so that the screen will be easy to see. An extremely bright or dark screen will give a bad effect to your eyes.

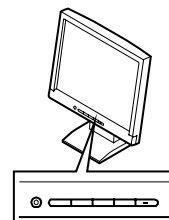

### Adjustment of Keyboard Angle

The keyboard provided with the server is designed for adjustment of an angle. Adjust the keyboard angle at which the keyboard is easy to operate. The adjustment assists in reducing strain on your shoulders, arms, and fingers.

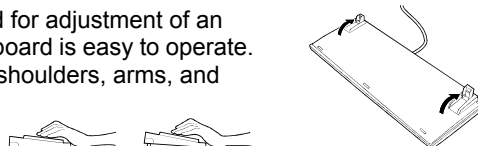

### Cleaning of Equipment

Clean equipment regularly. It is difficult to see the display contents on a dusty screen. Keeping equipment clean is also important for your sight.

### Fatigue and Rest

If you feel tired, you should stop working and do light exercises.



# Chapter 2

---

## General Description

This chapter provides information that you should be familiar with before using the server. It includes names and functions of the components and features of the server.

## OVERVIEW

Your server is a modular, multiprocessing server based on the Intel microprocessor family. It is a solid performer and offers the latest technology. The combination of compute performance, memory capacity, and integrated I/O provides a high performance environment for many server market applications. These range from large corporations supporting remote offices to small companies looking to obtain basic connectivity capability such a file and print services, e-mail, web access, web site server, etc. Your server is housed and available as a tower-based system.

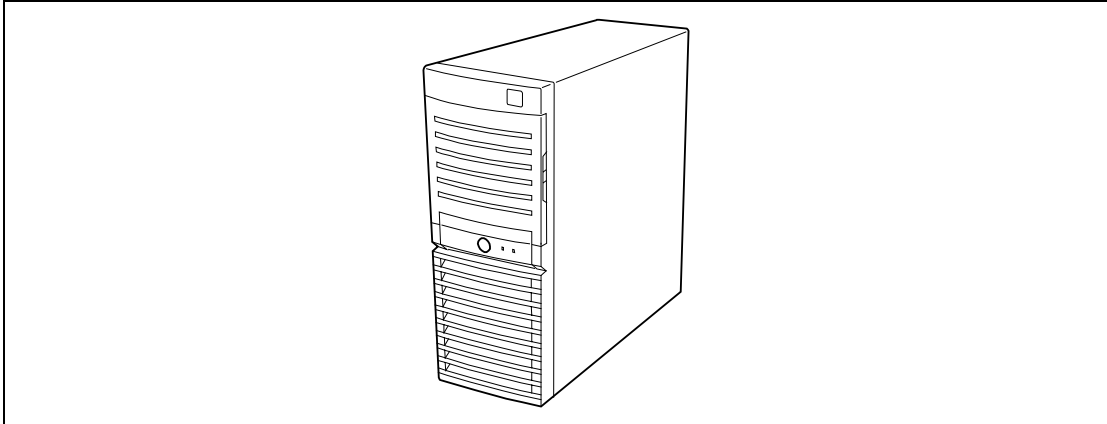

**Front View**

As application requirements increase, you can expand your server with an additional memory, add-in boards and peripheral devices; tape devices, DVD-ROM, and hard disk drives. The server features the following major components.

- A high-performance DualCore Intel® Xeon® Processor, Intel® Pentium® DualCore Processor, or Intel® Celeron® Processor
- Up to 8GB of memory (using 2GB DIMMs)  
Minimum configuration is 256MB of memory
- Dual channel memory configuration
- Four integrated I/O expansion PCI-e/PCI-X slots for add-in boards (two PCI Express slots and two 32-bit/33 MHz slots)
- Onboard enhanced IDE interface controller
- Onboard enhanced serial ATA RAID controller
- Onboard 1000/100/10 network controller
- Integrated optical disk drive
- Four hard disk drive bays
- Embedded PC-compatible support (serial, parallel, mouse, keyboard, USB, LAN, and video)
- High degree of SATA hard disk drive fault tolerance and advanced RAID management features through the use of RAID Technology.

## SYSTEM CHASSIS

Names and functions of the components are shown below.

### Front View

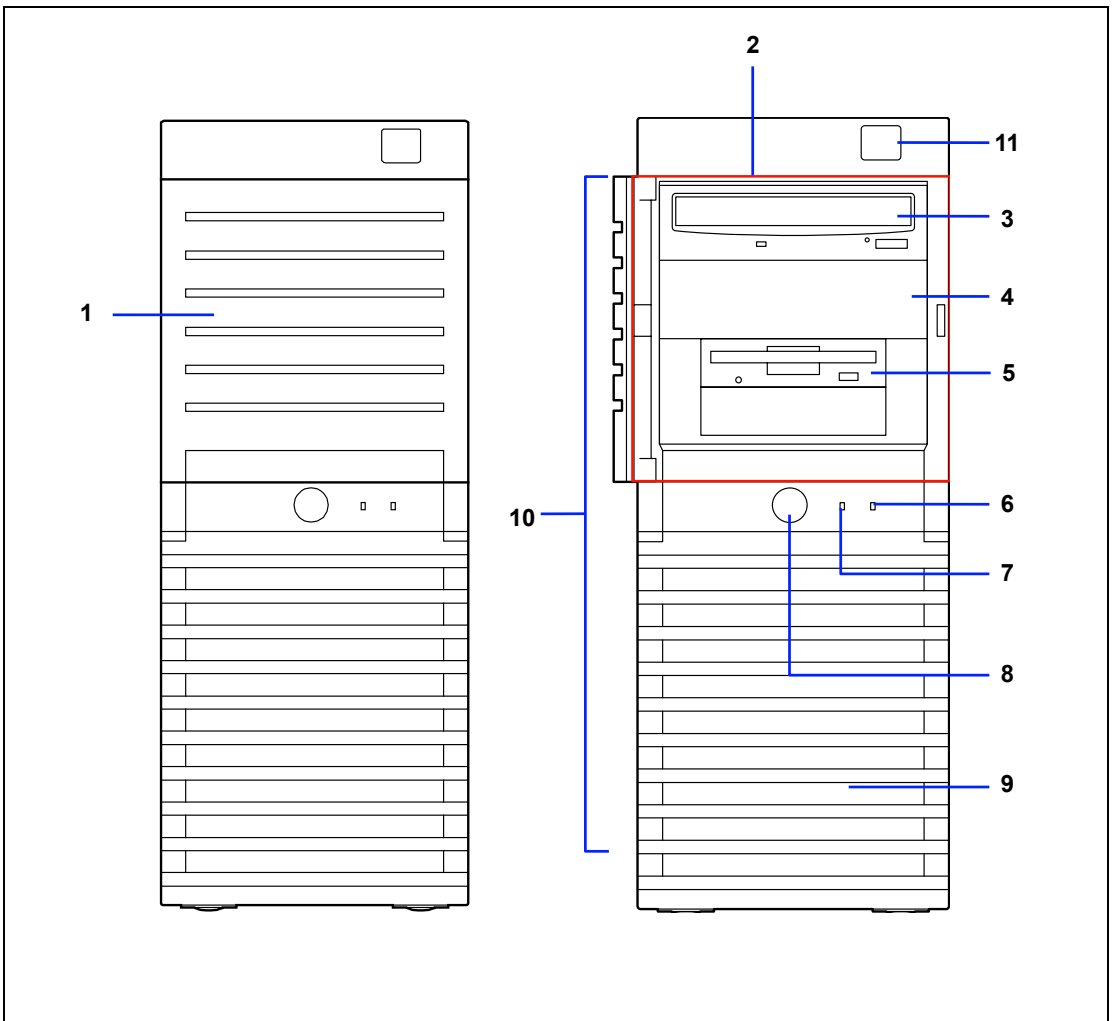

### 1 Front mask

Open the front mask when accessing the 5.25-inch device, 3.5-inch device, optical disk drive, and/or floppy disk drive.

### 2 File bay

The file bay contains both a 5.25-inch device bay and a 3.5-inch device bay.

### 3 Optical disk drive

The optical disk drive reads data from the inserted CD-ROM or DVD-ROM.

The drive is equipped with the following:

- Open/Close button to eject the tray
- Access lamp that indicates the disk access status
- Emergency hole to forcibly eject the tray

### 4 5.25-inch device bay

Up to two backup file devices of 5.25-inch width such as DAT drive or MO drive may be installed in the 5.25-inch device bay.

An optical disk drive is factory-installed on the top of bay.

### 5 3.5-inch floppy disk drive (option)

Reads/writes data from/to the 3.5-inch floppy disk inserted.

The floppy disk drive is equipped with the following:

- Eject button to eject the floppy disk
- Access lamp that indicates the floppy disk access status

### 6 Disk access lamp (green)

The disk access lamp is lit while the system accesses to a built-in hard disk drive. If the built-in hard disk drive is connected to the proper optional board, this lamp can be lit only when the LED cable provided with the system is connected.

### 7 POWER/SLEEP lamp (green)

Lights in green when the server is powered on. Blinks when the system is placed in the sleep mode.

### 8 POWER/SLEEP switch

The POWER/SLEEP switch is used to turn the power of the server ON/OFF. If you press this switch once, the power is turned on with the lamp going on green. If you press the switch again, the power is turned off.

Some OS setting can provide the function of switching to the power saving (sleep) mode. If you press the POWER/SLEEP switch once after the setting, the system is entered into the power saving mode. If you press the switch again, the system is returned to the normal state. (Depending on installed optional boards, the function cannot be provided.)

### 9 Front mask

The front mask protects the front face of the server.

### 10 Release tabs (3 at an end of front mask)

The release tabs are provided to release the lock of the front mask. Press the tabs to remove the front mask.

#### Front USB connector

Connect the USB device to this connector.

### Rear View

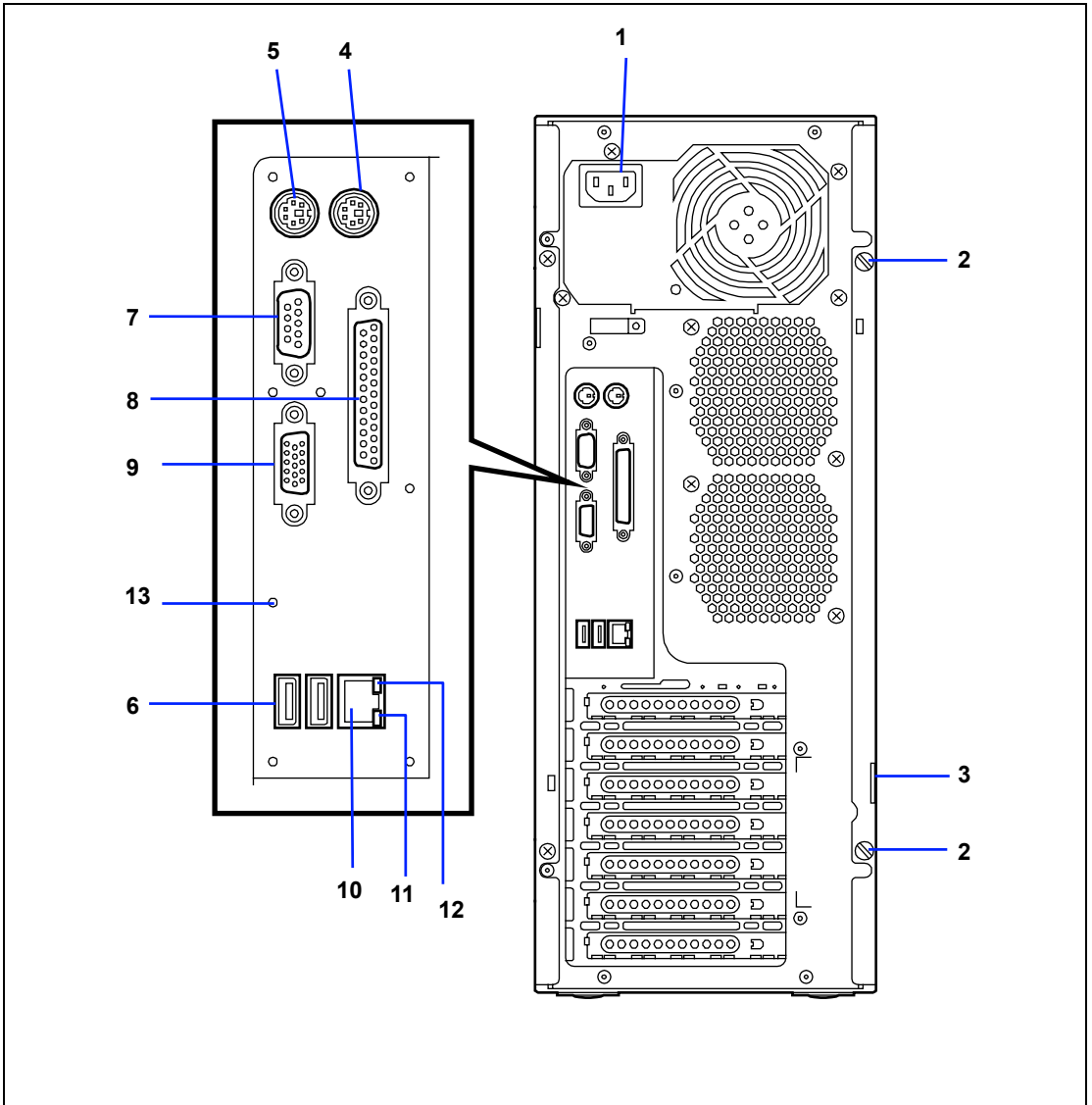

**1 AC inlet**  
The AC inlet is connected with the power cord.

**2 Fixing screws**  
Secures the left side cover.

**3 Cover lock plate**  
Installing a theft prevention device protects the internal components of the server from being stolen.

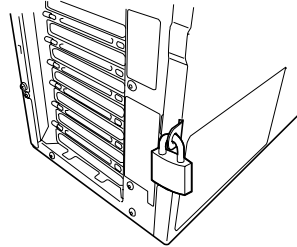

**4 Mouse connector**  
The mouse connector is connected with the mouse coming with the server.

**5 Keyboard connector**  
The keyboard connector is connected with keyboard coming with the server.

**6 USB connectors**  
The USB connectors are connected with devices accepting the USB interface.

**7 Serial port A connector**  
The serial port connector is used to connect the server to a device with the serial interface. The server cannot be directly connected to a leased line through the connector.

Note: If N8117-01A is connected, the connector on N8117-01A side becomes serial port B connector.

**8 Printer port connector**  
The printer port connector is connected with a printer with the Centronics interface.

**9 Monitor connector**  
The monitor connector is connected with the display unit.

**10 LAN connector**  
The LAN connector is connected with a network system on LAN (1000BASE-T/100BASE-TX/10BASE-T). The value following the bold-faced number indicates the port number.

**11 Link/ACT lamp**  
The Link/ACT lamp shows the LAN access status.

**12 1000/100/10 lamp**  
1000/100/10 lamp indicates the LAN transfer rate.

**13 NMI switch**  
Press this switch when collecting system event logs occurred in the system.

NOTE: Consult with your service representative before collecting logs. Collecting logs while the server is in the successful operation may affect the system operation.

## Internal View

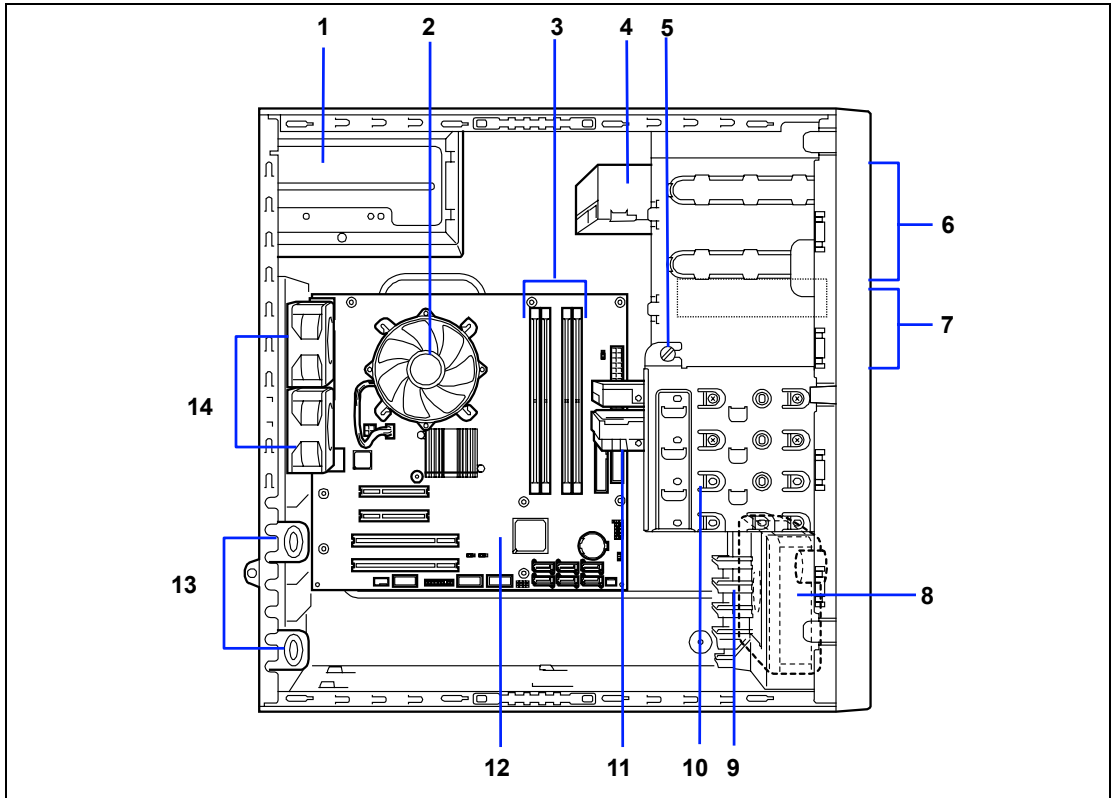

- 1 **Power supply**
- 2 **Processor cooling fan**
- 3 **DIMM slots**
- 4 **Optical disk drive**
- 5 **Device bay fixing screw**  
To remove the hard disk drive bay, loosen this screw. To remove the file bay, remove this screw.
- 6 **5.25-inch device bay**  
An optical disk drive is factory installed in top bay.
- 7 **3.5-inch floppy disk drive**
- 8 **Front cooling fan**
- 9 **PCI guide rail**
- 10 **Hard disk drive bay**
- 11 **Hard disk drive (optional)**
- 12 **Mother board**
- 13 **PCI board retention spring**
- 14 **Rear cooling fan**

## MOTHER BOARD

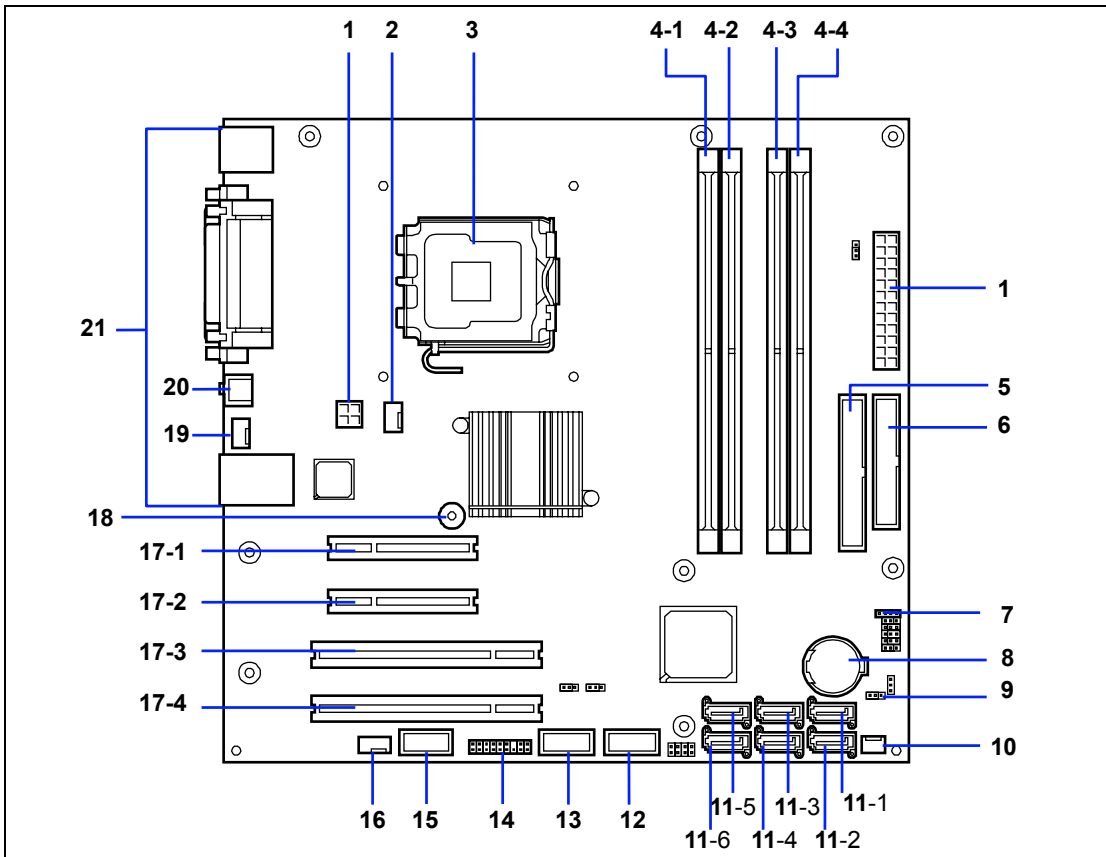

- |  |   |
|--|---|
| <b>1</b> Power connector   | <b>12</b> Internal USB connector (unused)   |
| <b>2</b> Rear cooling fan connector (for CPU)  | <b>13</b> Internal USB connector for front panel  |
| <b>3</b> Processor socket  | <b>14</b> LED connector   |
| <b>4</b> DIMM sockets<br>(The last digit indicates connector number.)                    | <b>15</b> Internal COM connector (unused)   |
| <b>5</b> IDE connector   | <b>16</b> Rear cooling fan connector  |
| <b>6</b> Floppy disk drive connector   | <b>17</b> PCI board slots<br>17-1: PCI Express x8<br>17-2: PCI Express x4<br>17-3, 17-4: 32bit/33 MHz |
| <b>7</b> LED/SW connector  | <b>18</b> Speaker   |
| <b>8</b> Lithium battery   | <b>19</b> Rear cooling fan connector  |
| <b>9</b> CMOS configuration jumper switch  | <b>20</b> NMI switch  |
| <b>10</b> PCI cooling fan connector  | <b>21</b> Connectors for external devices   |
| <b>11</b> Serial ATA connectors #1 to #6<br>(The last digit indicates connector number.) |   |

## STANDARD FEATURES

### High performance

- DualCore Intel® Xeon® Processor  
Intel® Pentium® DualCore Processor  
Intel® Celeron® Processor
- High-speed 100BASE-T/100BASE-TX/10BASE-T interface  
(1Gbps/100Mbps/10Mbps supported)
- High-speed disk access (SATA)
- Dual channel memory configuration

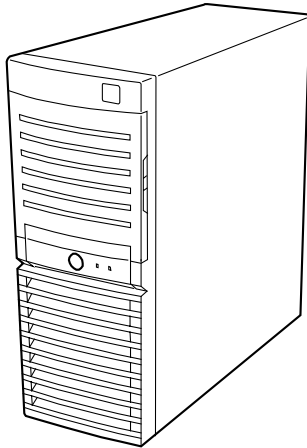

### Expandability

- Four integrated I/O expansion PCI slots
  - PCI Express (x8): 1 slot
  - PCI Express (x4): 1 slot (connector: x8)
  - PCI bus (32-bit/33MHz): 2 slots
- Large memory of up to 8GB  
(four 2GB DIMMs)
- USB interface (USB 2.0)

### High-reliability

- Memory monitoring feature (error correction/error detection)
- Temperature detection
- Cooling fan monitoring feature
- Voltage monitoring feature
- BIOS password feature
- RAID System (SATA)

### Many Available Features

- El Torito Bootable CD-ROM (no emulation mode) format support
- Remote power-on feature
- AC-LINK feature
- Onboard RAID controller (SATA)

### Self-diagnosis

- Power On Self-Test (POST)
- Test and Diagnosis

### Management Utilities

- NEC ESMPRO
- Off-line Maintenance Utility
- RAID System Management Utility

### Easy and Fine Setup

- NEC EXPRESSBUILDER (system setup utility)
- BIOS SETUP utility
- Parameter File Creator

### Power Saving Feature

- Sleep feature  
(available for Windows Server 2003)

---

## Remote Power-On Feature (Wake On LAN)

The remote power-on function turns on the server through a network. It sends a special packet from the management computer to a remote server to turn it on if the server is off-powered.

To enable this feature, you must select "Enabled" for each submenu in the Power Management Setup of the Advanced menu of the BIOS SETUP utility. (See Chapter 4.)

The remote power-on feature is not available in the following cases. Press the POWER/SLEEP switch once to start the OS, and turn off the server in an appropriate procedure.

- Abnormal previous system shut-down
- No power supply to the server (due to turned-off breaker, disconnected power cord, power blackout, etc.)

---

## AC LINK Feature

When the power cord of the server is connected to an uninterruptible power supply (UPS) unit, the server supports the power linkage feature that enables control over the power supply from the UPS to the server. The AC LINK feature can be enabled or disabled with Power Management Setup in the Server menu of the BIOS SETUP utility. (See Chapter 4.)

---

## Security

The BIOS SETUP utility provides a number of security features to prevent unauthorized or accidental access to the system. Once the security measures are enabled, access to the system is allowed only after the user enters the correct password(s). For example:

- Set and enable an administrative password.
- Set and enable a user password
- Check the user account when entering the BIOS SETUP utility or booting the system.

---

## NEC EXPRESSBUILDER

The DVD-ROM that comes with the server contains a setup utility called "NEC EXPRESSBUILDER."

The major functions of the NEC EXPRESSBUILDER are:

- To install the Operating System.  
"Express Setup" helps you to install the Windows Operating System. (See Chapter 5.)
  - To diagnose the system.  
NEC EXPRESSBUILDER includes the System Diagnostics to check your server. (See Chapter 6.)
  - To create a support disk.  
Use this function to create the support disks used to boot the utilities from the floppy disk, or the OEM-disk used for a manual installation of Windows. (See Chapter 6.)
  - To update the BIOS.  
Use this function to update the system BIOS or firmware of the server. (See Chapter 6.)
  - To update the Windows System\*  
"Update Express5800 system" in Windows Autorun Menu (Windows-based NEC EXPRESSBUILDER feature) updates the several resources of Microsoft Windows Server 2003. (See Chapter 6.)
  - To install the utilities.  
NEC EXPRESSBUILDER DVD includes some management software for Windows (NEC ESMPRO, NEC DianaScope and so on).  
You can install the applications for Windows from Windows Autorun Menu. (See Chapter 6.)
  - To read the online documents\*  
You can refer to the online documents from Windows Autorun Menu. (See Chapter 6.)
- \* These functions are available under the Windows system.

---

**NOTE:** Some features among those listed above can be used from the remote computer via cross cable (COM), or LAN. See Chapter 6 for details.

---

---

## NEC ESMPRO

The NEC ESMPRO is server management software that runs on the OS. The NEC ESMPRO includes the NEC ESMPRO Manager for the server monitoring terminal and the NEC ESMPRO Agent for the NEC Express server.

---

**NOTE:** For details of major functions of the NEC ESMPRO, system configuration and setups with the NEC ESMPRO, see Chapter 6. Available functions of the NEC ESMPRO depend on the OS you install. Ask your service representative for details.

---

---

## Maintenance Tools

The Maintenance Tools is used for maintenance and fault analysis of the server. This tool is usually used by the service representative.

---

## System Diagnostic Utility

The system diagnostic utility contained in the NEC EXPRESSBUILDER is useful to detect hardware failures. See Chapter 7 for details.

---

## Remote Management

The server may be monitored and managed via LAN/WAN by using EXPRESSSCOPE Engine 2 and NEC DianaScope utility stored in NEC EXPRESSBUILDER DVD.

The EXPRESSSCOPE Engine 2 provides the following features:

- Monitoring of temperature, voltage, fans, and electric power status
- Monitoring of power supply unit
- Monitoring of hard disk drives
- Generation of SEL (system event log) at occurrence of hardware failure
- Monitoring of the system management watchdog timer
- Monitoring of the periodic SMI timer
- Remote management by using Web browser (e.g., resetting the server, power on/off, viewing System Event Log (SEL))
- Remote KVM and remote device features (A separately priced remote management license is required.)
- Remote management via LAN/WAN by using NEC DianaScope and centralized management of several systems

For more information about remote management using Web browser, remote KVM feature, and remote device feature, refer to the "EXPRESSSCOPE Engine 2 User's Guide" stored in NEC EXPRESSBUILDER DVD.

---

**NOTE:** To use the Remote Management Extended License (N8115-03), visit our Web site to see the latest information about remote console/remote media feature.

---

## USING YOUR SERVER

This section describes basic operations of your server including how to use devices such as the floppy disk drive and the optical disk drive. See Appendix B for notes on using the floppy disk, CD-ROM, and accessories including the keyboard and the mouse.

---

### POWER Switch

Use the POWER/SLEEP switch to turn on/off the server.

#### Power On

Press the POWER switch on the front of the server.

The POWER/SLEEP lamp lights in green.

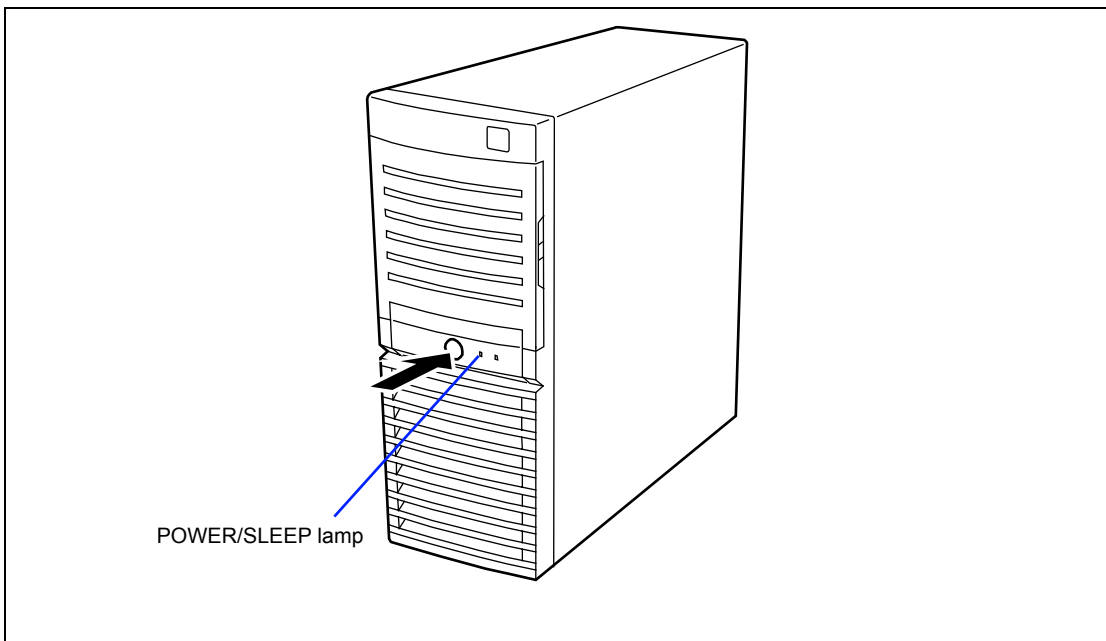

---

#### IMPORTANT:

- If the power cord is connected to a power control device such as a UPS (Uninterruptible Power Supply), make sure that the power control device is powered.
  - Do not turn off the server until characters appear on the screen.
-

## POST

POST (Power On Self-Test) is the self-diagnostic program stored in the system memory.

When you power on the server, the system automatically runs POST to check the mother board, ECC memory module, CPU module, keyboard, and mouse. POST also displays messages of the BIOS Setup utility, such as the start-up message, while in progress.



With the factory setup of the server, the NEC logo appears on the display unit while POST is in progress. (To display the POST check results, press **Esc**.)

---

**NOTE:** You can set the POST check results to appear on the display unit without pressing **Esc**. To do so, select "Enabled" for "Boot-time Diagnostic Screen" under the Advanced menu of the BIOS SETUP utility.

---

You don't always need to check the POST check results. Check messages that POST displays when:

- you use the NEC Express server for the first time.
- the server appears to fail.
- the server beeps for many times between power-on and OS start-up.
- an error message appears on the display unit.

## POST Execution Flow

The following describes the progress of POST in the chronological order.

---

### IMPORTANT:

- Do not power off the server while POST is in progress.
  - Do not make key entries or perform mouse operations while POST is in progress.
  - Some system configurations may display the message "Press Any Key" to prompt a key entry. This message is driven by BIOS of an installed optional board. Make sure to read the manual that comes with the optional board before any key entry.
  - Powering on the server, after you installed or removed an optional PCI board or moved it to another slot, may display the message that indicates incorrect board configuration and suspend POST. In such a case, press **F1** to continue POST. Board configuration can be made using the utility described later.
- 

1. After a few seconds from power-on, POST starts checking the memory. The count message of the basic and expansion memory appears at top left on the display unit screen. The memory check may takes a few minutes to complete depending on the memory size of the server. Also, it may take approximately one minute for the screen display to appear after rebooting the server.
2. Some messages appear upon completion of the memory check. These messages appear to indicate that the system has detected the CPU, keyboard, and mouse.
3. After a few seconds, POST displays the following message prompting you to launch the BIOS SETUP utility, stored in the system memory of the server. This message appears at bottom left on the screen.

Press <F2> to enter SETUP or Press <F12> to boot from Network

Launch the BIOS SETUP utility when you need to change the settings to meet the requirements for the server. As long as the above message is not displayed with an error message, you don't have to launch the utility. (Ignore the message. POST will automatically proceed.)

To launch the BIOS SETUP utility, press **F2** while the above message is displayed. See Chapter 4 for setup and parameters.

The server automatically restarts POST all over again when you exit the BIOS SETUP utility.

4. If your server uses Onboard RAID Controller, the following message is displayed to prompt you to run RAID utility.

Press <Ctrl><M> to Run LSI SoftwareRAID Configuration Utility

Press **Ctrl + M** to run the utility. For detail explanation, see Chapter 4 for detail.

---

**IMPORTANT:** The LSI Software RAID Configuration Utility is used to manage the data stored in hard disk drive, or for maintenance. See Chapter 4 for detail.

---

5. If the POST detects the optional add-in card, it displays the message prompting you to launch the add-in card BIOS configuration utility. (Ignore the message. POST will automatically proceed a few seconds later.)

Refer to the manual that comes with the optional add-in card for detail.

6. If you set a password entry using the BIOS SETUP utility, the password entry screen appears upon successful completion of POST.

Up to three password entries will be accepted. Three incorrect password entries disable the server to boot. In such a case, turn off the power and wait about ten seconds before turning on to boot the server.

---

**IMPORTANT:** Do not set a password before installing an OS.

---

7. The OS starts when POST completes.

## POST Error Messages

When POST detects an error, it displays an error message on the display unit screen or emits beep code. See Chapter 8 for POST error codes.

---

**IMPORTANT:** Take a note on the messages displayed before consulting with your sales agent. Alarm messages are useful information for maintenance.

---

## Power Off

Follow the procedure below to power off the server. If the power cord of the server is connected to a UPS, refer to the manual that comes with the UPS or the manual for the application that controls the UPS.

---

**IMPORTANT:** Always allow POST to complete before turning off the server.

---

1. Shut down the OS.
2. Press the POWER/SLEEP switch on the front of the server.  
The POWER/SLEEP lamp goes out.
3. Power off peripheral devices.

---

## SLEEP Switch

The POWER/SLEEP switch allows you to save almost all power of the server (power-saving mode or sleep mode).

Press the POWER/SLEEP switch on the front of the server to place the server in the power-saving mode. (The POWER/SLEEP lamp blinks.) In the power-saving mode, the server retains the memory data and the status of the previous operations.

To resume the original state, press the POWER/SLEEP switch again. (It may take a little time to resume the original state.)

---

**NOTE:** The operational level in the power-saving mode depends on the OS in use. (Available for Windows Server 2003.)

---

---



**IMPORTANT:** Do not change system configuration while turning into the power-saving mode or in the power-saving mode. Otherwise, you may fail to resume the original state.

---

---

## Optical Disk Drive

The server is provided with the optical disk drive on its front to read/write data from/to a disc.

 <b>CAUTION</b>	
 	<p>Observe the following instructions to use the server safely. Failure to follow these instructions may cause a fire, personal injury, or property damage. See pages 1-3 to 1-8 for details.</p> <ul style="list-style-type: none"><li>■ Do not leave the tray ejected from the optical disk drive.</li><li>■ Take off the headphone before you plug in the headphone jack.</li></ul>

### Setting and Removing the Disc

1. Make sure that the power of the server is on (with the POWER/SLEEP lamp being lit in green) before setting the disc on the optical disk drive.
2. Press the Open/Close button on the front of the optical disk drive.  
The tray comes out.
3. Put the disc on the tray carefully and securely with the character printed surface facing upward.
4. Press the Open/Close button or gently push on the tray front.  
The tray is automatically retracted into the optical disk drive.

---

**IMPORTANT:** If a noisy sound in driving the optical disk drive occurs after setting a disc, set it again correctly.

---

To take out the disc from the optical disk drive, press the Open/Close button in the similar way in setting the disc to make the tray go out. If the access LED is lit orange or green, the disc is being accessed. Confirm that the access LED is not lit before pressing the Open/Close button.

Your OS may have a command to eject the tray.

When you have taken out the disc, retract the tray back in place.

### When you fail to eject:

When you fail to eject the tray with the Open/Close button and take out the disc from the server, follow the procedure below.

1. Press the POWER switch to power off the server. (The POWER/SLEEP lamp goes off.)
2. Insert a metal pin of approximately 1.2 mm in diameter and 100 mm in length (a straightened large paper clip will make a substitute) into the emergency hole on the front of the optical disk drive and gently push it in until the tray is ejected.

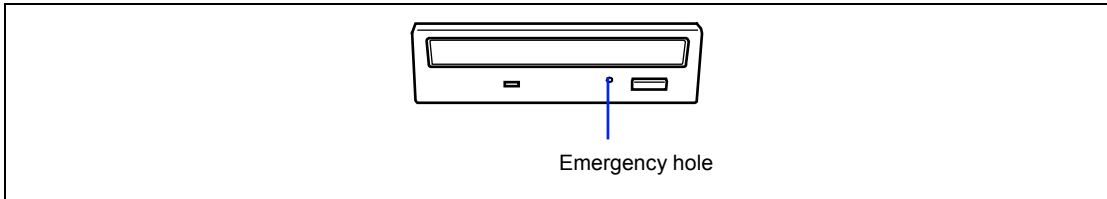

---

#### **IMPORTANT:**

- Do not use a toothpick or plastic stick that is easy to break.
  - If the above procedure does not let you take out the DVD/CD-ROM, contact your service representative.
- 

3. Hold the tray and pull it out.
4. Take out the disc.
5. Push the tray back into position.

## Use of the Disc

Keep the following notes in mind to use the disc for the server:

- For the disk which does not conform to the CD standard, the playback of such a disk with the CD drive is not guaranteed.
- Do not drop the disc.
- Do not place anything on the disc or bend the disc.
- Do not attach any label onto the disc.
- Do not touch the signal side (nothing is printed on this side) with your hand.
- Place the disc with its printed side upward and gently put it on the tray.
- Do not scratch the disc or write anything directly on it with a pencil or ball-point pen.
- Keep the disc away from cigarette smoke.
- Do not leave the disc in a high-temperature place (e.g., place exposed to direct sunlight or close to a heater).
- When dust or fingerprints are attached on the disc, wipe the disc from its center to edge with a dry soft cloth slowly and gently.
- Use the CD cleaner to clean the disc. Do not use record spray/cleaner, benzene, or thinner.
- Keep the disc in a disc case when not in use.
- If the disc emits large noise in the optical disk drive, remove the disc and insert it back again.

(This page is intentionally left blank.)

# Chapter 3

---

## Setting Up Your Server

This chapter describes how to set up your server appropriate for your system, on a step-by-step basis.

## SETUP FLOW

Follow the flowchart below to set up the server.

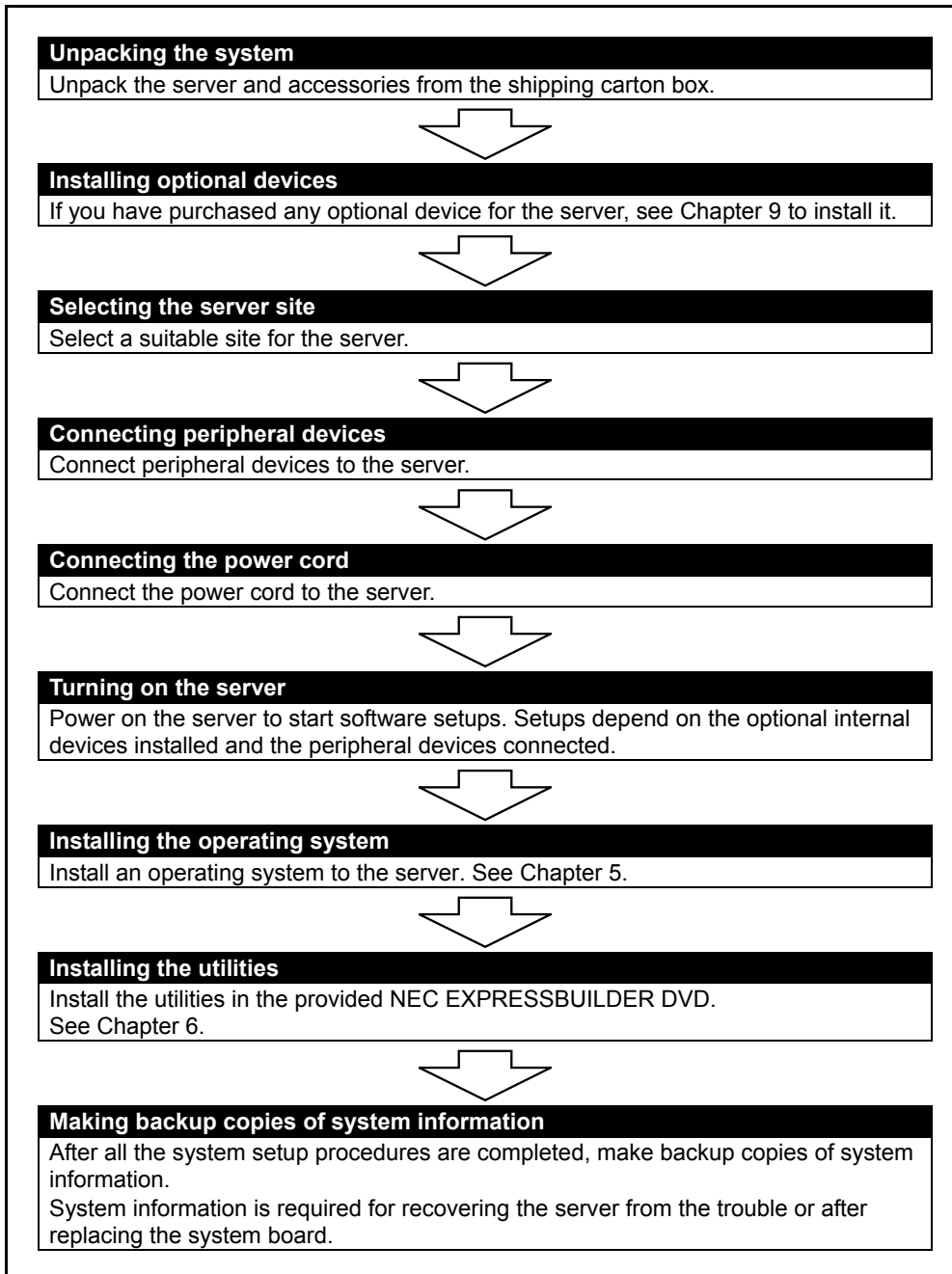

## UNPACKING THE SYSTEM

When you receive your system, inspect the shipping containers prior to unpacking. If the shipping boxes are damaged, note the damage, and if possible, photograph it for reference. After removing the contents of the containers, keep the cartons and the packing materials. If the contents appear damaged when you unpack the boxes, file a damage claim with the carrier immediately.

## INSTALLING OPTIONAL DEVICES

To install any optional device, see Chapter 9, "Upgrading Your Server," for the installation procedure. Proceed to the next section if you have no optional devices to install.

---

**IMPORTANT:** There are third-party products (memory modules, hard disk drives, etc.) available for the server in the markets. However, NEC recommends that you should use NEC products for stable operation. NEC assumes no liability for data errors and failures due to malfunction of the server resulted from installation of those third-party products.

---

## SELECTING SERVER SITE

Read the following precautions before selecting a suitable site for your server. The following describes installation of the server and connections to the server.

**⚠ CAUTION**



Observe the following instructions to use the server safely. Failure to follow these instructions may cause a fire, personal injury, or property damage. See pages 1-3 to 1-8 for details.

- Never attempt to lift the server only by yourself.
- Do not install the server in any place other than specified.

The following figure illustrates a site suitable for installing the server.

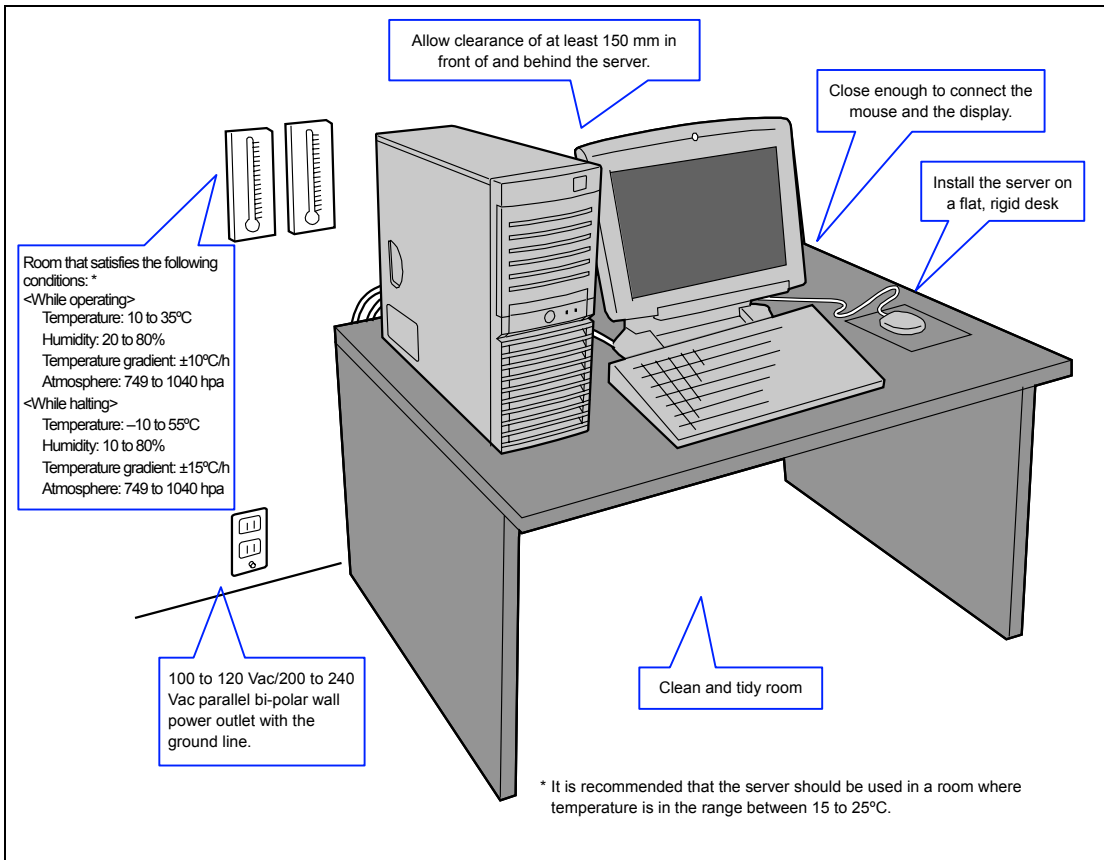

When you have selected a server site, hold the server by its bottom with at least three persons and carry it to the site, then place it slowly and gently.

---

**IMPORTANT:** Do not hold the server by its front mask to lift the server. The front mask may be disengaged and damage the server.

---

Do not install the server in the following locations as it may cause malfunctions of the server.

- Places with drastic changes in temperature (e.g., near a heater, air conditioner, or refrigerator)
- Places with strong vibration
- Places with corrosive gas in presence, near chemicals, or with possibilities of chemicals sprayed over
- On a non-antistatic carpet
- Places with possibilities of falling objects
- Places where a power outlet that shares the ground line with another (especially the one to which a device with large power consumption is connected) must be used for the server
- Do not install the server near equipment that generates power noise (e.g., contact spark at power-on/power-off of commercial power supply through a relay). (To install the server near equipment that generates power noise, ask your service representative for separating the power wiring or installing a noise filter.)

## CONNECTING PERIPHERAL DEVICES

Connect peripheral devices to the server. The server is provided with connectors for wide variety of peripheral devices. The figure on the next page illustrates available peripheral devices for the server in the standard configuration and locations of the connectors for the devices.

<b>⚠ CAUTION</b>	
	<p>Observe the following instructions to use the server safely. Failure to follow these instructions may cause a fire, personal injury, or property damage. See pages 1-3 to 1-8 for details.</p> <ul style="list-style-type: none"><li>■ Do not use any damaged cable connector.</li><li>■ Do not use any unauthorized interface cable.</li><li>■ Do not use the server with any loose interface connection.</li><li>■ Do not step on the interface cable or place any heavy object on it.</li></ul>

---

### IMPORTANT:

- Power off the server and a peripheral device before connection. Connecting a powered peripheral device to the powered server will cause malfunctions and failures.
  - To connect a third-party peripheral device or interface cable to the server, consult with your service representative for availability of such a device or cable. Some third-party devices may not be used for the server.
  - To connect the provided keyboard and mouse, plug their connectors to the server with the "Δ" mark on the connectors facing right.
  - Do not connect the serial ports with the telephone line directly.
  - Do not connect any devices to the connectors not instructed in this subsection. Doing so could damage the device, your server, or both.
-

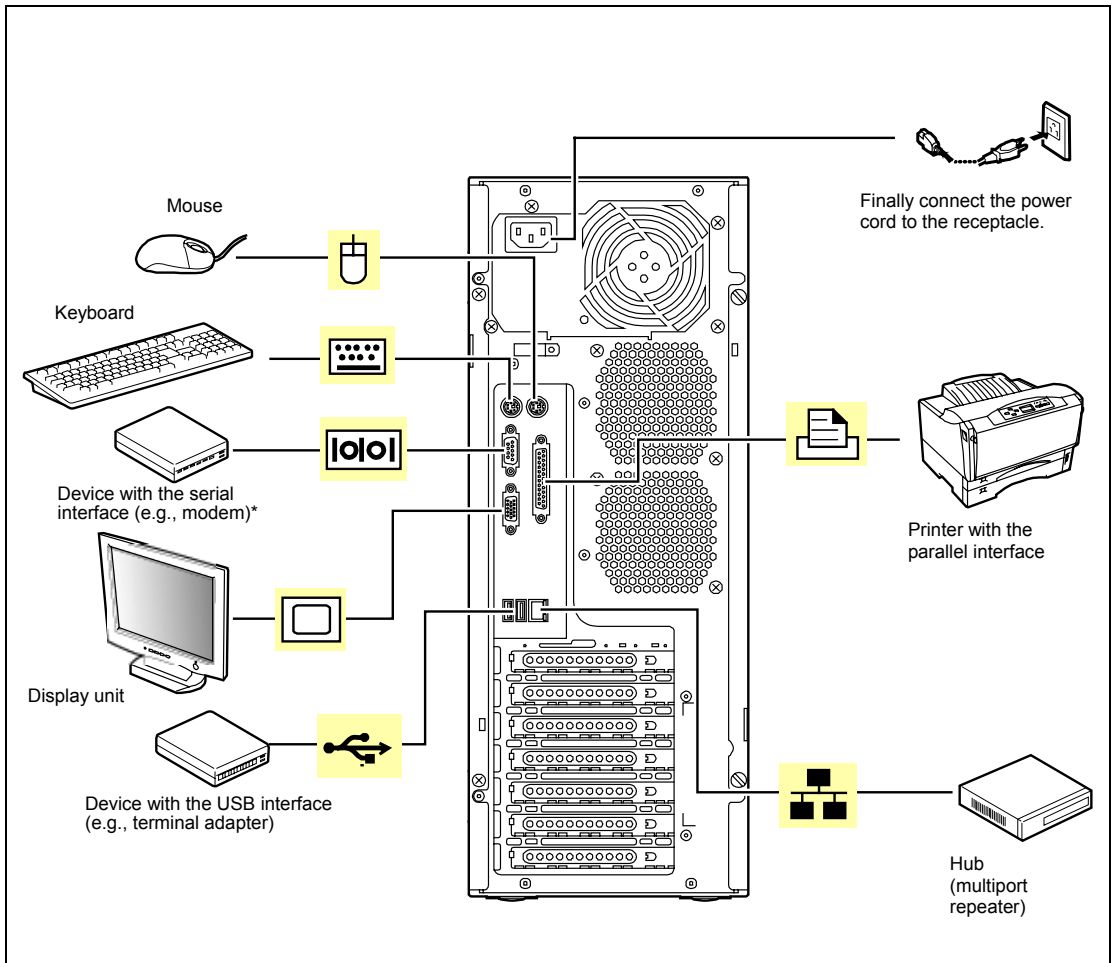

## CONNECTING POWER CORD

Connect the provided power cord to the server.

### ⚠ WARNING



Observe the following instructions to use the server safely. Failure to follow these instructions may result in death or serious personal injury. See pages 1-3 to 1-8 for details.

- Do not hold the power plug with a wet hand.

### ⚠ CAUTION



Observe the following instructions to use the server safely. Failure to follow these instructions may cause a fire, personal injury, or property damage. See pages 1-3 to 1-8 for details.

- Do not plug the power cord in to an improper power source.
- Do not connect the power cord to an outlet that has an illegal number of connections.
- Insert the power plug into the outlet as far as it goes.
- Use the authorized power cord only.

1. Plug the provided power cord into the power receptacle on the rear of the server.
2. Plug the other end of the power cord into the wall outlet.

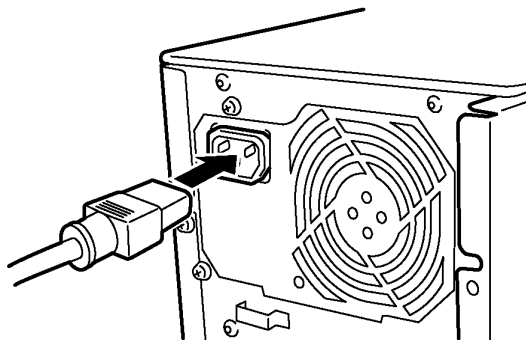

---

**NOTES:**

- To connect the power cord from the server to an uninterruptible power supply (UPS), use service outlets on the rear of the UPS. Refer to the manual that comes with the UPS for details.
  - When the power cord from the server is connected to a UPS, change the BIOS SETUP utility of the server to link with power supply from the UPS.  
Change a parameter for "AC-LINK" of the Server menu of the BIOS SETUP utility. See Chapter 4 for details.
-

## TURNING ON THE SERVER

Turn on the server and follow the on-screen instructions for setup.

---

**IMPORTANT:** Before turning on the server:

- Some optional boards require setups with the BIOS SETUP utility before installation. If the server has a PCI board with the PCI-to-PCI bridge installed, the BIOS SETUP utility is enabled to launch. Check on the board specifications to find out whether it requires pre-installation setups before actually installing the board.
- Some installed optional devices or connected peripheral devices require setups before proceeding to the next step.

To use the server with no optional devices installed besides the graphic board, install a desired OS to the server.

---

1. Make sure all external devices, such as a video display, keyboard, and mouse (optional) have been connected, and the power cords are connected.
2. Power on the video display and any other external devices.
3. Make sure that the floppy disk drive contains no floppy disk and the optical disk drive contains no bootable DVD/CD-ROM.
4. Press the POWER/SLEEP switch.

---

### NOTES:

- If the power cord is connected to the power control unit such as the UPS, turn on the power control unit.
  - Connect the power cord and wait a few seconds before pressing the POWER switch. The POWER/SLEEP switch does not work in a few seconds after connecting the power cord due to firmware start-up.
- 

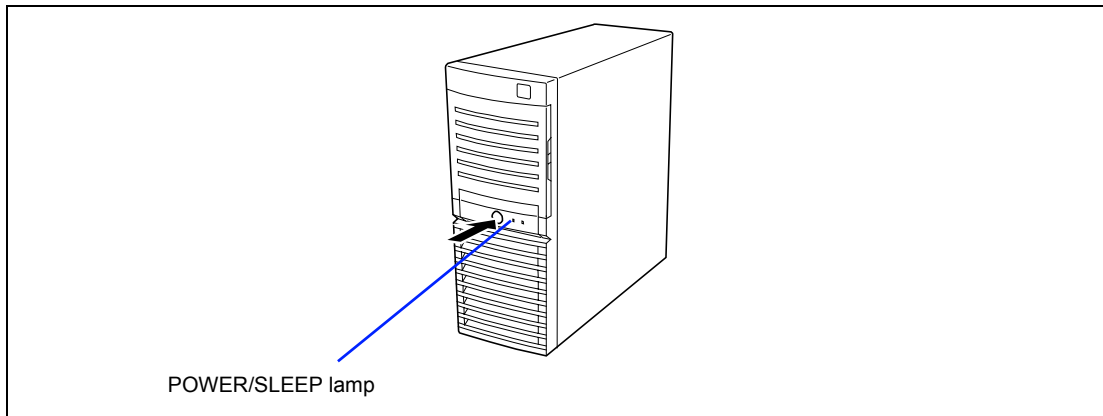

The POWER/SLEEP lamp on the front of the server comes on.

In a few seconds, the NEC logo appears on the screen and the Power On Self-Test (POST) begins.

The POST runs automatically when you power on the server or reset it with a keyboard operation (**Ctrl + Alt + Delete**). The POST runs diagnostics, initializes the server, sets interrupt vectors, detects installed peripheral devices, and boots the operating system (if installed). See Chapter 2 for detailed description on POST.

If the server halts before completing the POST, the POST emits a beep code indicating a fatal system error requiring immediate attention. (See Chapter 8, "Troubleshooting," for troubleshooting information.)

During memory test, the POST displays the amount of memory it was able to access and test. Depending on the amount of installed memory, it may take several minutes to complete the memory test.

---

**NOTE:** The factory-set is defined to hide the POST screen with the NEC logo screen. You can always change the NEC logo screen to the POST screen by pressing **Tab**. To change the start-up screen, use the BIOS SETUP utility. (See Chapter 4 for details.)

---

During the POST, you will see the banner message to prompt you to launch the BIOS SETUP utility stored in ROM on the mother board or on an installed option board.

Start the BIOS SETUP utility appropriate to your system environment to change the CMOS Setup. For detail explanation on the BIOS SETUP utility for the server, see Chapter 4. For the BIOS utility for the option board, refer to the manual that comes with the option board.

---

**IMPORTANT:** Always allow POST to complete before turning off your system.

---

## INSTALLING OPERATING SYSTEM

See Chapter 5 for installing Microsoft Windows Server 2003.

To install the other operating system listed above, contact your service representative.

---

**IMPORTANT:** Use NEC EXPRESSBUILDER for initial setup of your server. The NEC EXPRESSBUILDER is a support software for the server. It simplifies the process of installing and configuring your server. See Chapter 6 for details on NEC EXPRESSBUILDER.

---

## INSTALLING UTILITIES

Install the utilities that come with the server. See Chapter 6 for details.

## MAKING BACKUP COPIES OF SYSTEM INFORMATION

The system information includes the current BIOS settings and any specific information for the server.

Save the information after completing the system setup.

Without the backup data, you will not be able to recover the information.

You can save the information by the following process.

1. Insert the NEC EXPRESSBUILDER DVD into the optical disk drive and reboot the system.
2. Select [Tool menu (Normal mode)].
3. Select [English].
4. Select [Maintenance Utility].
5. Select [System Information Management].
6. Insert a floppy disk into the floppy disk drive.
7. Select [Save].

# Chapter 4

---

## Configuring Your Server

Configuration and setup utilities are used to change your system configuration. You can configure your system, as well as option boards you may add to your system, using the BIOS SETUP Utility. Several unique system parameters are configured using the BIOS SETUP, which is stored in the system FLASH memory.

The RAID configuration utility configures the RAID System and logical drives connected to the Onboard RAID controller or optional RAID controller.

If your system has been factory configured, the BIOS SETUP or RAID configuration utility do not need to be run unless you want to change the password or security features, add certain types of option boards or devices, upgrade your system board, or change the RAID configuration.

This chapter also provides information on several system configuration parameters that are set by jumpers on the system board. However, these parameters do not usually require change.

## SYSTEM BIOS (BIOS SETUP UTILITY)

The BIOS Setup utility is provided to make basic hardware configuration for the server. This utility is pre-installed in the flash memory of the server and ready to run.

The server is configured with the correct parameters using the BIOS Setup utility and shipped in the best conditions. Thus, you don't need to use the BIOS Setup utility in most cases. However, you might wish to use the BIOS Setup utility in the cases described below.

---

### IMPORTANT:

- The BIOS Setup utility is intended for system administrator use only.
  - The BIOS Setup utility allows you to set a password. The server is provided with two levels of password: Supervisor and User. With the Supervisor password, you can view and change all system parameters of the BIOS Setup utility. With the User password, system parameters available for viewing and changing are limited.
  - Do not set any password before installing the OS.
  - The server contains the latest version of the BIOS Setup utility. Dialog boxes appear on your BIOS Setup utility, thus, may differ from descriptions in this manual. If you find anything unclear, see the online help or ask your service representative.
- 

---

## OS Supporting Modes for Onboard SATA Controller

When using the onboard SATA controller, the following modes are supported by your OS.

- Windows 2003: Supports AHCI mode or RAID mode
  - Setting AHCI mode
    - Run BIOS Setup and select [Advanced] → [Peripheral Configuration] → [SATA AHCI Enable] → [Enabled].
  - Setting RAID mode
    - Use the RAID configuration jumper switch. See "Configuration by Onboard RAID Controller" described later.



## Description on On-Screen Items and Key Usage

Use the following keyboard keys to work with the BIOS Setup utility. These keys are also listed at the bottom of the menu screen.

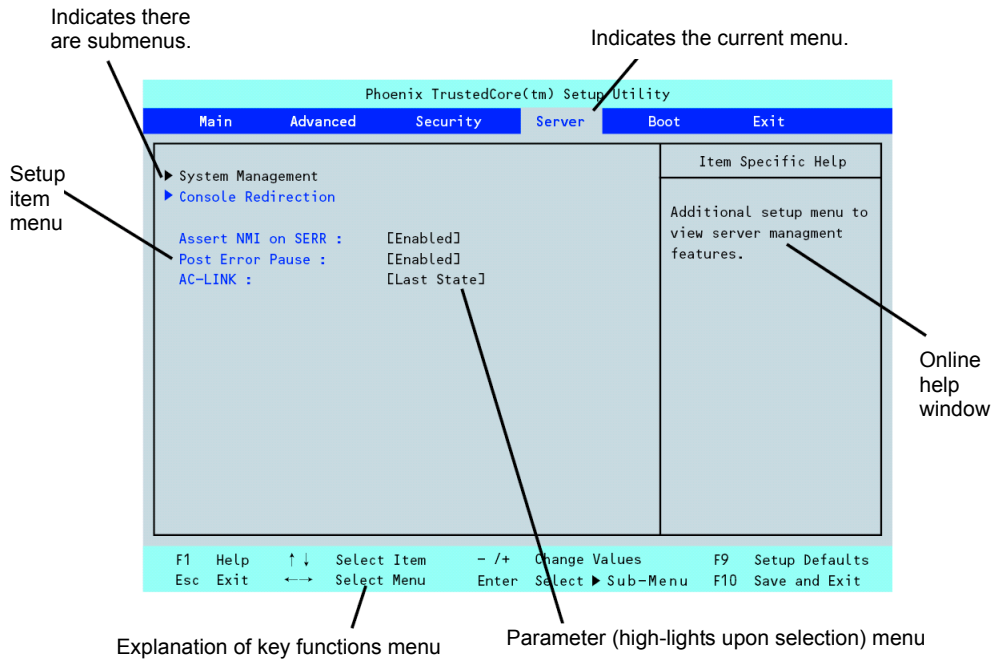

- Cursor (↑, ↓):** Move cursor up and down. The cursor moves only to the settings that you can change.
- Cursor (←, →):** Move between menus.
- and +:** Select the previous value (-) or the next value (+) for the field.
- Enter** Execute command or select ▶ submenu.
- Esc** Exit the current menu and return to the previous menu.
- F1:** Get Help about an item.
- F9:** Load default configuration values for this menu.
- F10:** Save configuration values and exit.

---

## Configuration Examples

The following describes examples of configuration required to use software-link features or for system operations.

### Time and Date Settings

You can also change the time and date settings via the operating system commands.

Select [Main] - [System Time].

Select [Main] - [System Date].

### Link with Management Software

To control power supply of the server with NEC ESMPRO Manager via the network

Select [Advanced] - [Advanced Chipset Control] - [Wake On LAN/PME] - [Enabled].

Select [Server] - [AC LINK] - [Stay Off].

### UPS

To link power supply with the UPS

- To power on the server when power is supply from the UPS

Select [Server] - [AC LINK] - [Power On].

- To keep the server off-powered even when power is supplied from the UPS

Select [Server] - [AC LINK] - [Stay Off].

### Boot

To check the boot order

Select [Boot] and check the current boot order.

To change the boot order of devices connected to the server

Select [Boot] and specify the boot order.

---

**IMPORTANT:** If you have installed any bootable device, be sure to run BIOS Setup menu to check the boot priority on [Boot] menu. If the bootable device is displayed in "Excluded from boot order", put the cursor onto the device, then press **x** to move it to "Boot priority order".

---

## Memory

To check the installed memory (DIMM board) status

Select [Advanced] - [Memory Configuration] and check the status indications.

The on-screen DIMM group numbers and socket locations on the motherboard are associated as shown in the following figure.

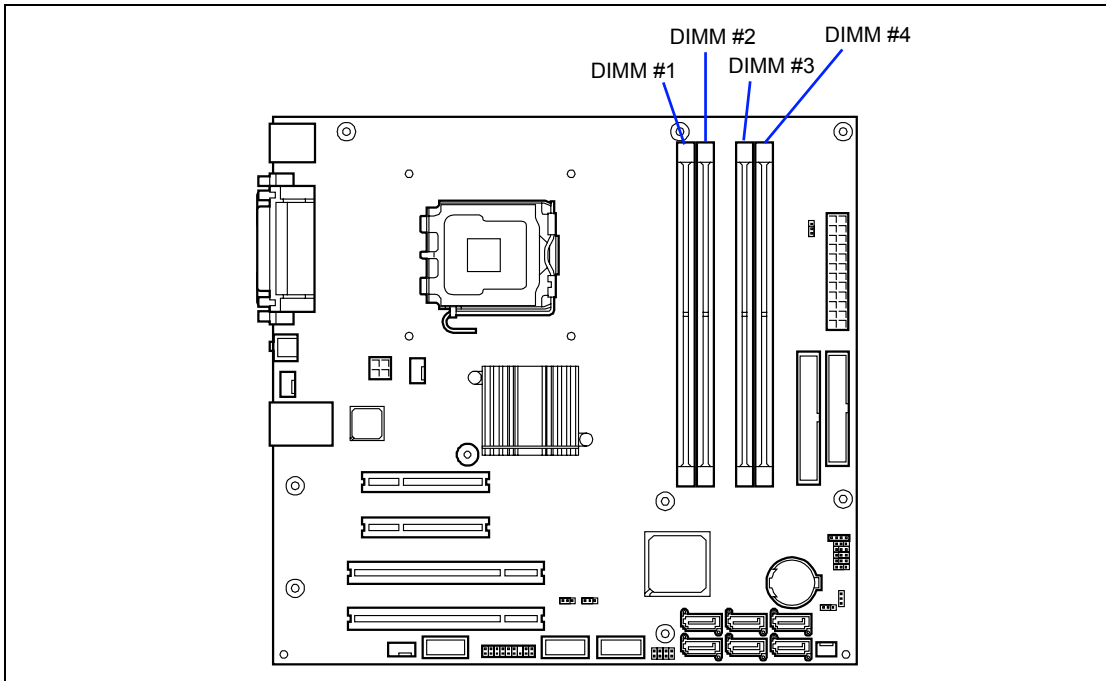

To clear the memory (DIMM board) error information

Select [Advanced] - [Memory Configuration] - [Memory Retest] - [Yes] and reboot.

To run power-on memory test

Select [Advanced] - [Memory Configuration] - [Extended RAM Step] - [1MB] and reboot.

## CPU

To check the installed CPU status

Select [Main] - [Advanced Processor Options] - [Processor CPUID] and check the status indications.

To clear the CPU error information

Select [Main] - [Advanced Processor Options] - [Processor Retest] - [Yes] and reboot.

## Keyboard

To set Numlock

Select [Advanced] - [Numlock] – [On]/[Off].

## Security

To set passwords on the BIOS

Select [Security] - [Set Supervisor Password] and enter a password.

Select [Security] - [Set User Password] and enter a password.

Set Supervisor password first, then User password.

## External Devices

To set up external devices

Select [Advanced] - [Peripheral Configuration] and set up each device.

## Internal Devices

To install the RAID controller card or SCSI controller card

Select [Advanced] - [PCI Configuration] - [PCI Slot n Option ROM] - [Enabled].

n: slot number

To clear the hardware configuration data (after installing/removing internal devices)

Select [Advanced] - [Reset Configuration Data] - [Yes] and reboot.

## Saving the Configuration Data

To save the current configuration data and exit from SETUP

Select [Exit] - [Exit Saving Changes].

To discard changes to the current configuration data and exit from SETUP

Select [Exit] - [Exit Discarding Changes].

To load the default setup

Select [Exit] - [Load Setup Defaults].

To discard changes to the current configuration data

Select [Exit] - [Discard Changes].

To save the current configuration data

Select [Exit] - [Save Changes].

## Menu and Parameter Descriptions

The SETUP utility has the following six major menus:

- Main
- Advanced
- Security
- Server
- Boot
- Exit

To set minute functions, select a submenu from the above menus. The following describes available functions and parameters, as well as the factory-set, for each menu.

### Main

If BIOS Setup is started, the Main menu appears first. If you select a menu item preceded by symbol ► and press **Enter**, the appropriate submenu appears.

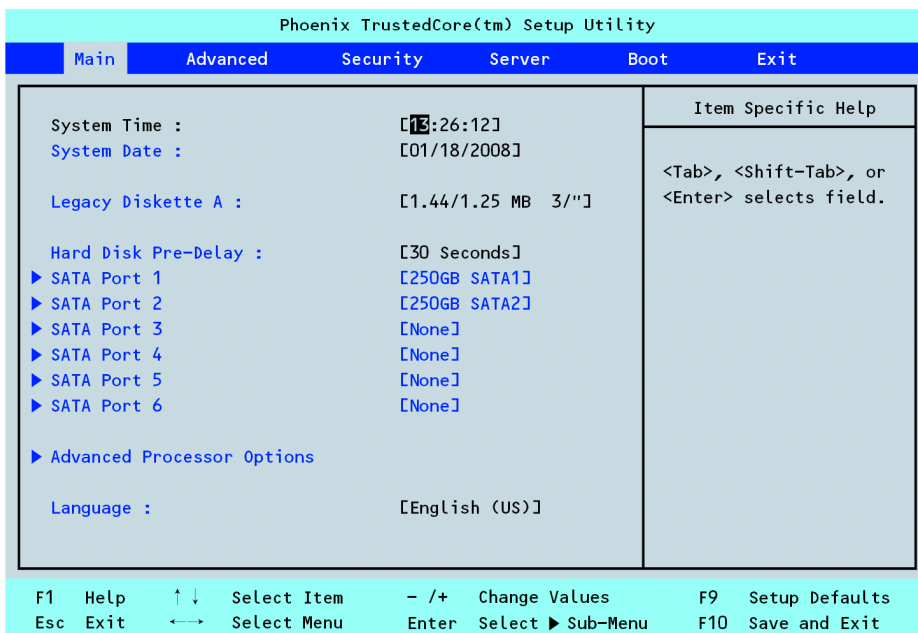

The items which can be set on the Main menu screen and their functions are described below.

Option	Parameter	Description	Your Setting
System Time	HH:MM:SS	Set the system time.	
System Date	MM/DD/YYYY	Set the system date.	
Legacy Diskette A	[Disabled] 360Kb 5 <sup>1</sup> / <sub>4</sub> 1.2MB 5 <sup>1</sup> / <sub>4</sub> 720Kb 3 <sup>1</sup> / <sub>2</sub> 1.44/1.25MB 3 <sup>1</sup> / <sub>2</sub> 2.88MB 3 <sup>1</sup> / <sub>2</sub>	Set the settings of optional floppy disk drive. If you install an optional internal floppy disk drive, set this item to "1.44/1.25MB 3 <sup>1</sup> / <sub>2</sub> ". If you replace the floppy disk drive with internal backup device and use the external USB floppy disk drive for reinstallation of OS or maintenance work, set this item to "Disabled".	
Hard Disk Pre-Delay	Disabled 3 seconds 6 seconds 9 seconds 12 seconds 15 seconds 21 seconds [30 seconds]	When accessing the internal SATA hard disk drive for the first time during POST, the system waits for the specified time until the drive becomes ready.	
SATA Port 1 - 6	–	Displays the type of devices connected to each port. The settings of some items may be changed. However, leave the items as they are at the shipment.	
Advanced Processor Options	Select submenu	Shows the processor settings submenu.	
Language	[English (US)] Français Deutsch Español Italiano	Select which language BIOS displays.	

[ ]: Factory-set

**IMPORTANT:** Check and adjust the system clock before the operation if any of the following conditions is applicable.

- After carriage of device
- After storage of device
- After the device is entered into the pause state under the environmental condition enduring device operation (temperature: 10°C - 35°C, humidity: 20% - 80%)

Check the system clock at the rough rate of once per month. When the system clock is installed in a system requiring high time precision, it is recommended to use a time server (NTP server).

If the system clock is remarkably delayed or advanced as the passage of time in spite of adjustment, contact your service representative for maintenance.

### Advanced Processor Options

If you select "Advanced Processor Options" on the Main menu, the screen shown below appears. The menu displayed depends on the installed CPU.

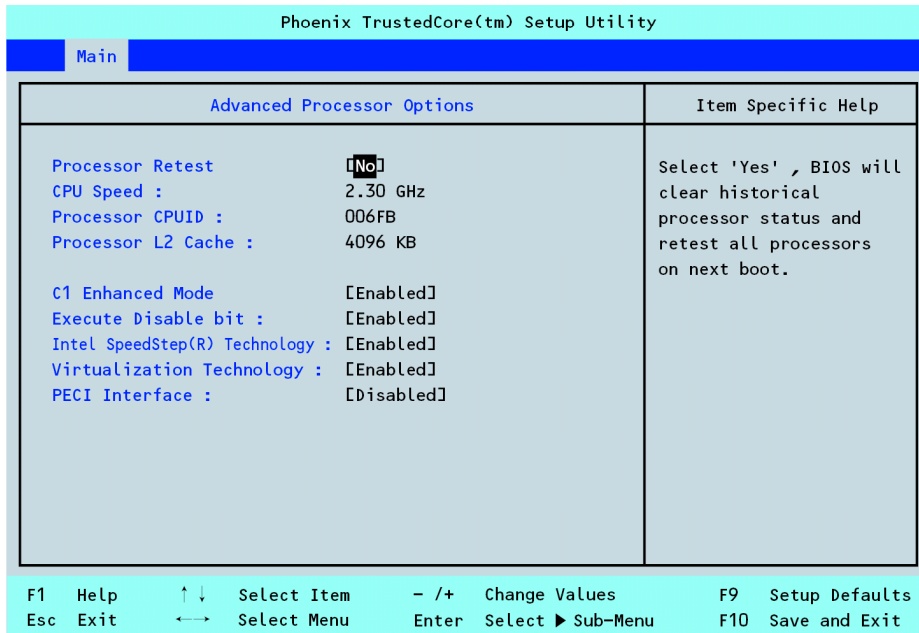

See the table below for the items.

Option	Parameter	Description	Your Setting
Processor Retest	[No] Yes	If yes, BIOS will clear historical processor status and retest the processor on the next boot.	
CPU Speed	nnn GHz	Displays clock speed for the processor. (View only)	
Processor CPUID	Numeral Error	Displays CPU ID for processor, if present. "Error" indicates that the processor is defected. (View only)	
Processor L2 Cache	nnn KB	Displays L2 cache size for processor. (View only)	
C1 Enhanced Mode	[Enabled] Disabled	Displayed only when the CPU supports Enhanced Halt State (C1). Specify whether to enable or disable this feature.	
Execute Disable Bit	[Enabled] Disabled	Displayed only when the CPU supports Execute Disable Bit. Specify whether to enable or disable this feature.	
Intel SpeedStep(R) Technology	[Enabled] Disabled	Specify whether to enable or disable the Intel SpeedStep Technology. This menu is displayed only when the installed CPU supports this technology.	
Virtualization Technology	[Enabled] Disabled	Specify whether to enable or disable the virtualization technology of Intel processor. This menu is displayed only when the installed CPU supports this technology.	
PECI Interface	Enabled [Disabled]	The server does not support Peci interface. Always set this item to [Disabled].	

[ ]: Factory-set

## Advanced

The Advanced menu appears if you move the cursor to the position of "Advanced".

If you select a menu item preceded by symbol ► and press **Enter**, the appropriate submenu appears.

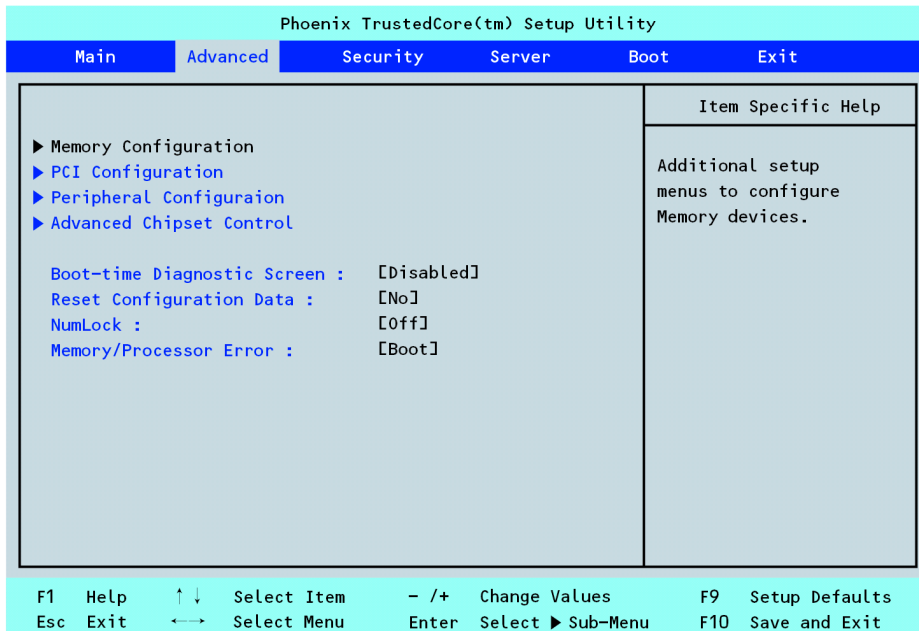

See the table below for the items.

Option	Parameter	Description	Your Setting
Boot-time Diagnostic Screen	[Disabled] Enabled	Specify whether the power-on self-test (POST) running screen is displayed or not on booting. If disabled, the BIOS will display the NEC logo during POST. Press <b>Esc</b> to switch to the POST running screen.	
Reset Configuration Data	[No] Yes	Select "Yes" if you want to clear the system configuration data stored in POST. This parameter is automatically reset to "No" at the next boot.	
NumLock	[On] Off	Specify whether to enable or disable the Numlock feature at system start-up.	
Memory/Processor Error	[Boot] Halt	Specify whether to stop POST execution if a memory or processor error was detected during POST.	

[ ]: Factory-set

## Memory Configuration

The following screen appears if you select "Memory Configuration" on the Advanced menu.

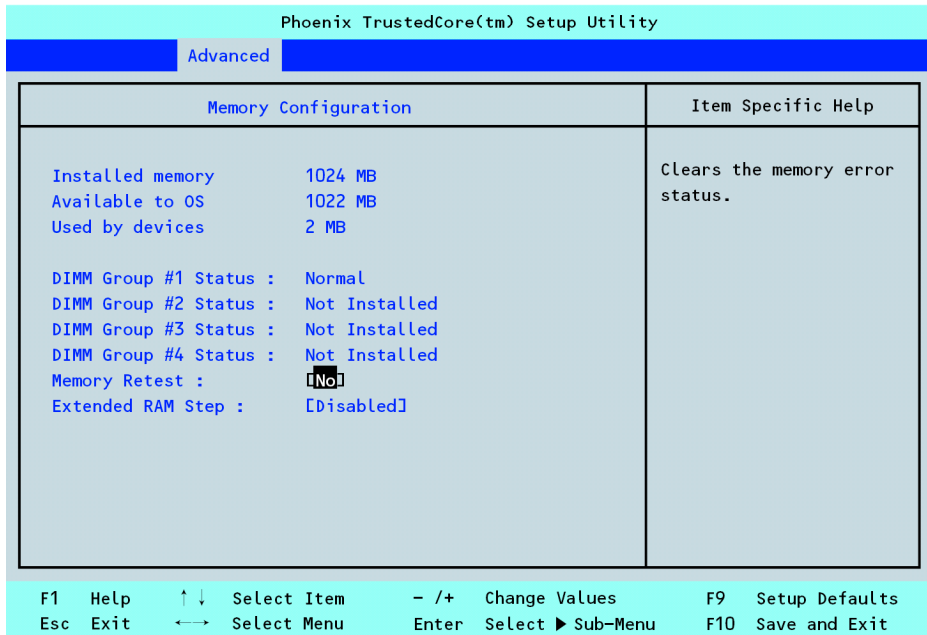

See the table below for the items.

Option	Parameter	Description	Your Setting
Installed memory	–	Indicates the total capacity of the base memory. (View only)	
Available to OS	–	Indicates the total capacity of the memory available for OS. (View only)	
Used by devices	–	Indicates the total capacity of the base memory used by devices. (View only)	
DIMM Group #1 - #4 Status	Normal Not installed Disabled	Indicates the current memory status. (View only) "Normal" indicates that the memory devices operate normally. "Not Installed" indicates that no memory devices are installed. "Disabled" indicates that one or more memory devices are defected.	
Memory Retest	[No] Yes	Specify whether to execute a memory retest for all memory devices.	
Extended RAM Step	1MB [Disabled]	Specify whether to execute a memory test for extended memory or not. If the test is executed, specify the block size.	

[ ]: Factory-set

### PCI Configuration

The following screen appears if you select "PCI Configuration" on the Advanced menu. Selecting an item on the screen allows the proper submenu to appear.

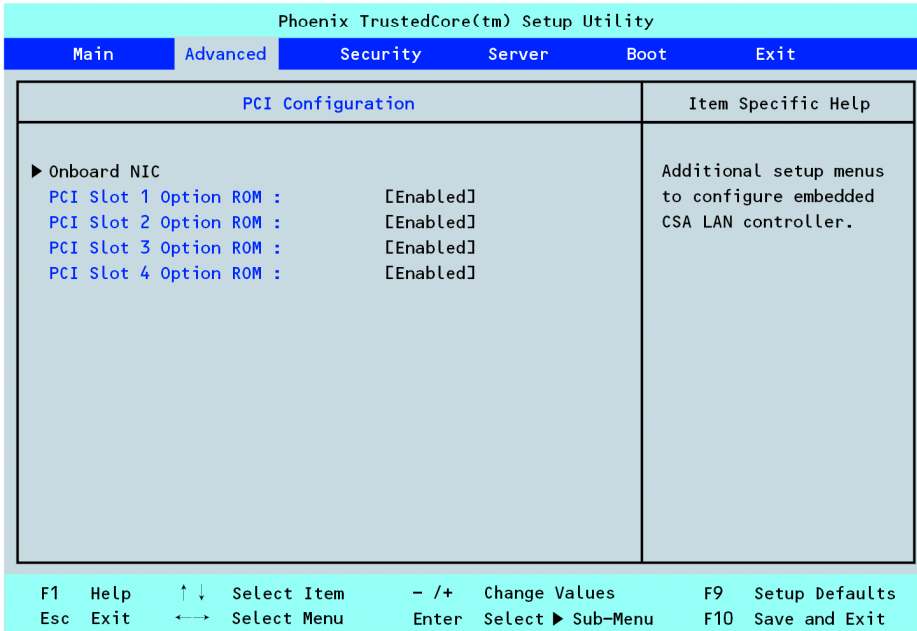

See the table below for the items.

Option	Parameter	Description	Your Setting
PCI Slot 1-4 Option ROM	[Enabled] Disabled	Displays the submenu to specify whether to enable or disable the BIOS on the device (board) connected to PCI slot. Set this item to "Enabled" when the RAID controller or SCSI controller is connected with the hard disk drive which contains an OS. Set this item to "Disabled" when the LAN controller which contains ROM BIOS is used but the board does not provide network booting. Disabling Option ROM Scan saves memory consumption and time for startup.	

[ ]: Factory-set

## Onboard NIC

The following screen appears if you select "Onboard NIC" on the "PCI Configuration" of Advanced menu.

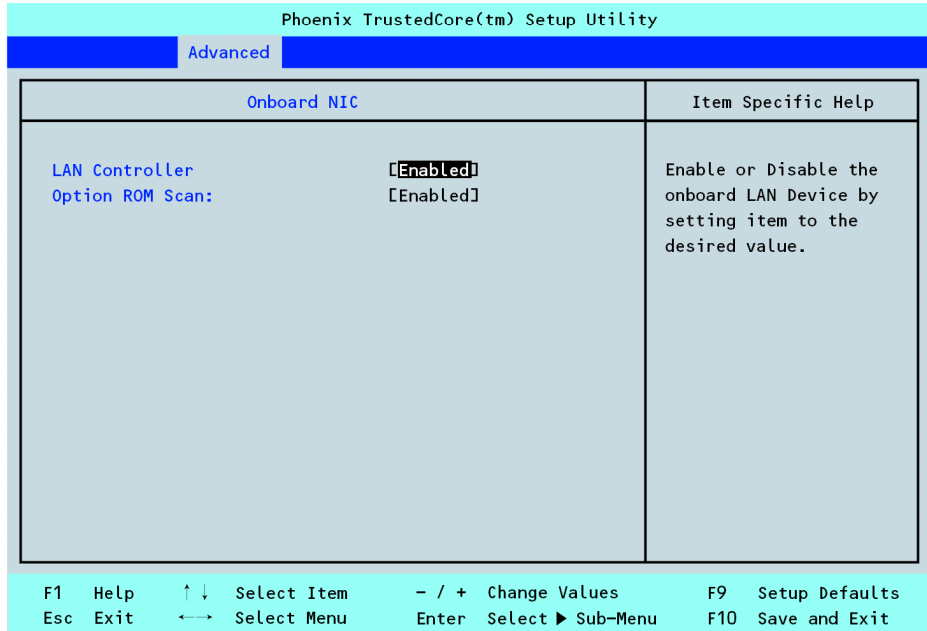

See the table below for the items.

Option	Parameter	Description	Your Setting
LAN Controller	Disabled [Enabled]	Specify whether to enable or disable the onboard LAN controller.	
Option ROM Scan	Disabled [Enabled]	Displays a submenu to specify whether to enable or disable option ROM scan of onboard LAN controller.	

[ ]: Factory-set

### Peripheral Configuration

The screen shown below appears if you select "Peripheral Configuration" on the Advanced menu.

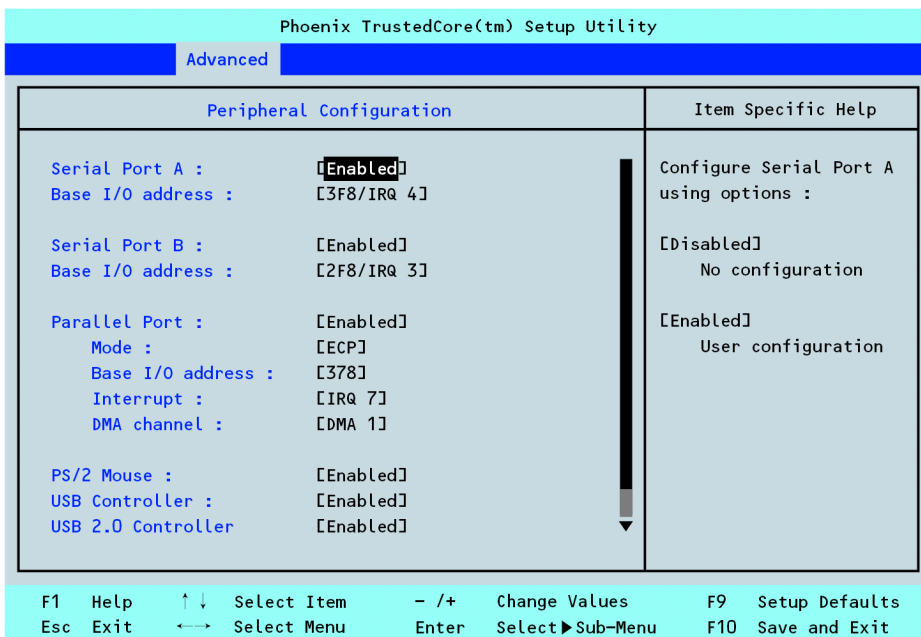

See the table below for the items.

**IMPORTANT:** Note that the interrupt and/or base I/O address are not overlapped with others. If the value set for the interrupt or base I/O address is used in another resource, the yellow asterisk (\*) appears. Reset any item with the yellow asterisk properly.

Option	Parameter	Description	Your Setting
Serial Port A	Disabled [Enabled]	Selects whether serial port A is enabled or disabled.	
Base I/O Address	[3F8/IRQ4] 2F8/IRQ3 3E8/IRQ4 2E8/IRQ3	Selects the base I/O address for serial port A.	
Serial Port B	Disabled [Enabled]	Selects whether serial port B is enabled or disabled (display only).	
Base I/O Address*	3F8/IRQ4 [2F8/IRQ3] 3E8/IRQ4 2E8/IRQ3	Selects the base I/O address for serial port B.	
Parallel Port	Disabled [Enabled]	Selects whether the parallel port is enabled or disabled.	
Mode	Bi-directional EPP [ECP]	Selects the operation mode of the parallel port.	

Option	Parameter	Description	Your Setting
Base I/O address	[378] 278	Selects the base I/O address for parallel port.	
Interrupt	IRQ5 [IRQ7]	Selects the interrupt for parallel port.	
DMA channel	[DMA1] DMA3	Selects the interrupt for parallel port.	
PS/2 Mouse	Disabled [Enabled]	If disabled, PS/2 mouse port will not function.	
USB Controller	Disabled [Enabled]	If disabled, the USB ports do not accept the USB device class 3 (HID: Human Interface Deice).	
USB 2.0 Controller	Disabled [Enabled]	If disabled, the USB2.0 device will not function.	
Legacy USB Support	Disabled [Enabled]	Selects whether the USB keyboard is made available in OS which does not support USB formally.	
Serial ATA	Disabled [Enabled]	Selects whether the serial ATA is enabled or disabled.	
Native Mode Operation	Auto [Serial ATA]	Selects the native mode for ATA. Auto: I/O port is assigned as legacy IDE-compatible device. Serial ATA: I/O port is assigned as PCI device. Note: A specific OS does not support the native mode.	
SATA RAID Enable	[Disabled] Enabled	Indicates whether the RAID disk drives that uses the onboard SATA is enabled or disabled. (View only) Note: If you attempt to start the system from SATA hard disk drive with different setting, the data may be destroyed.	
SATA AHCI Enable	Disabled [Enabled]	Selects whether the native SATA interface (AHCI: Advanced Host Controller Interface) is enabled or disabled. Note: If you use the onboard SATA controller, the supported mode depends on OS you are using.	
SATA AHCI Legacy Enable	[Disabled] Enabled	Selects whether the AHCI Legacy mode is enabled or disabled. This menu appears only when [SATA AHCI Enable] is set to "Enabled".	

[ ]: Factory-set

### Advanced Chipset Control

The following screen appears if you select "Advanced Chipset Control" on the Advanced menu.

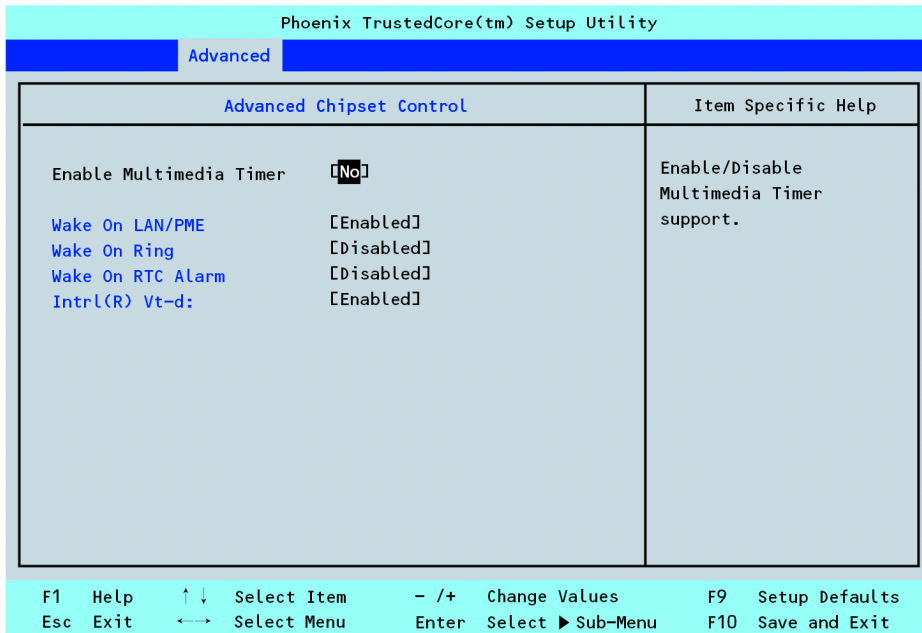

See the table below for the items.

Option	Parameter	Description	Your Setting
Enable Multimedia Timer	[No] Yes	Specify whether the timer corresponding to multimedia is enabled or disabled.	
Wake On LAN/PME	Disabled [Enabled]	Specify whether the remote power-on function through network is enabled or disabled.	
Wake On Ring	[Disabled] Enabled	Specify whether the remote power-on function through a serial port is enabled or disabled.	
Wake On RTC Alarm	[Disabled] Enabled	Specify whether the remote power-on function by using RTC alarm feature is enabled or disabled.	
Intel(R) Vt-d	Disabled [Enabled]	Specify whether the "Intel(R) Virtualization Technology for Directed I/O" of Intel chipset is enabled or disabled. This item is displayed only when the processor supports this feature.	

[ ]: Factory-set

## Security

The Security menu appears if you move the cursor to the position of "Security".

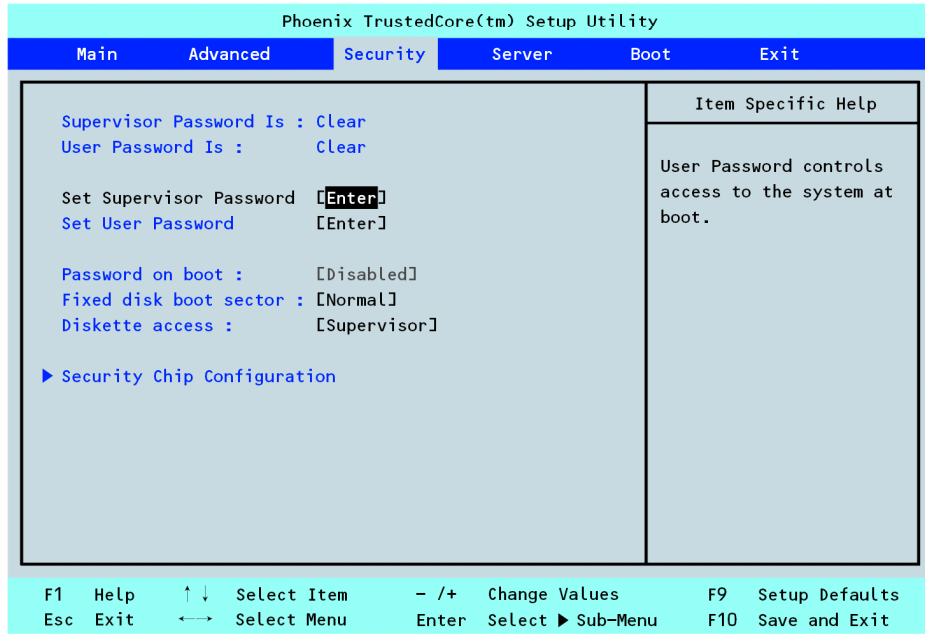

Press **Enter** on "Set Supervisor Password" or "Set User Password" to display the dialog to set/change password.

---

### IMPORTANT:

- User password can be set only when Supervisor password is already set.
  - Set the passwords only after OS is installed.
  - If you forget the passwords, contact your service representative.
-

See the table below for the items.

Option	Parameter	Description	Your Setting
Supervisor Password Is	Clear Set	Indicates the password setting status.	
User Password Is	Clear Set	Indicates the password setting status.	
Set Supervisor Password	Up to eight alphanumerics	Press <b>Enter</b> to display the supervisor password input screen. This password enables all the SETUP menus to be accessed. This setting can be done only on login with the password input of "Supervisor" at start of SETUP.	
Set User Password	Up to eight alphanumerics	Press <b>Enter</b> to display the user password input screen. For this password, accessing to the SETUP menu is restricted.	
Password on boot*	[Disabled] Enabled	Specify whether the passwords are entered or not on booting. At first the supervisor password must be set. If the supervisor password is set and this option is disabled, BIOS determines that a user is booting.	
Fixed disk boot sector	[Normal] Write Protect	Specify whether to permit writing into boot sector of the hard disk drive or not.	
Diskette access*	User [Supervisor]	Set an authority to access the floppy disk in floppy disk drive.	

[ ]: Factory-set

\* You can set this item on [Set Supervisor Password] menu.

### Security Chip Configuration

Selecting "Security Chip Configuration" on the Security menu shows the following screen. The screen shows when [TPM Support] is set to [Enabled].

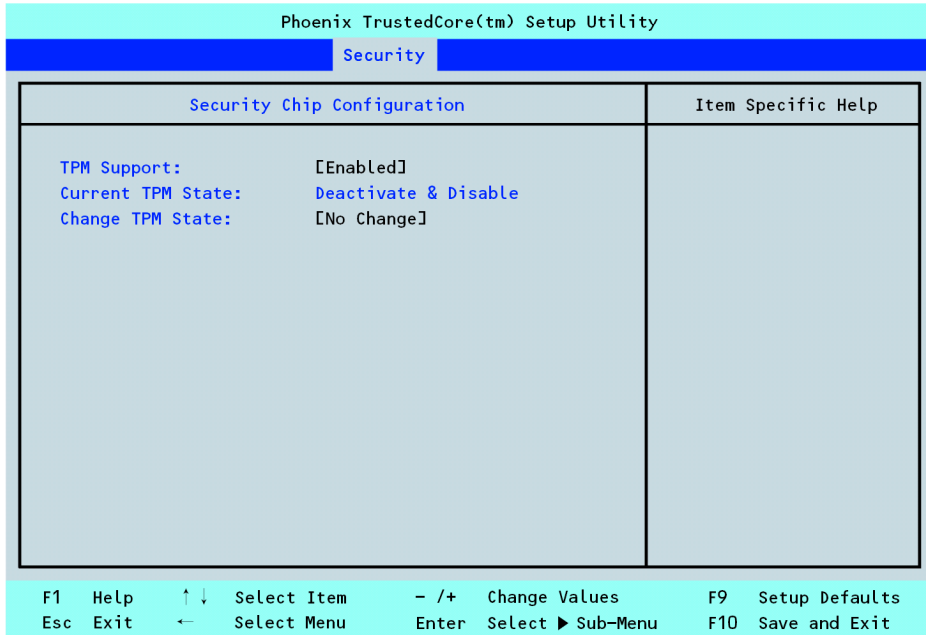

See the table below for the items.

Option	Parameter	Description	Your Setting
TPM Support	[Disabled] Enabled	Specify whether the TPM (Trusted Platform Module) is enabled or disabled.	
Current TPM State	–	This menu appears only when "Enabled" is selected in [TPM Support]. Indicates the TPM State currently being set. (Display only)	
Change TPM State	[No Change] Enable & Activate Deactivate & Disable Clear	This menu appears only when "Enabled" is selected in [TPM Support]. Select [Enable & Activate] to use the TPM features. If you change parameter for this item, a confirmation screen appears at the end of POST after restarting the system. Select [Execute] on the confirmation screen.	

[ ]: Factory-set

**IMPORTANT:** If you select any parameter except for [No Change] to change TPM State, a confirmation screen as shown below appears at the end of POST after restarting the system. Select [Execute] on the confirmation screen to determine the change you have made.

When [Enable & Activate] is selected:

```
Physical Presence operations

TPM configuration change was requested to
State:  Enable & Activate

Note:
This action will switch on the TPM

Reject
Execute
```

When [Deactivate & Disable] is selected:

```
Physical Presence operations

TPM configuration change was requested to
State:  Deactivate & Disable

Note:
This action will switch off the TPM

WARNING!!!
Doing so might prevent security applications
that rely on the TPM from functioning
as expected

Reject
Execute
```

When [Clear] is selected:

```
Physical Presence operations

TPM configuration change was requested to
State:  Deactivate & Disable

Note:
This action will switch off the TPM

WARNING!!!
Doing so might prevent security applications
that rely on the TPM from functioning
as expected

Reject
Execute
```

---

## Server

The Server menu appears if you move the cursor to "Server".

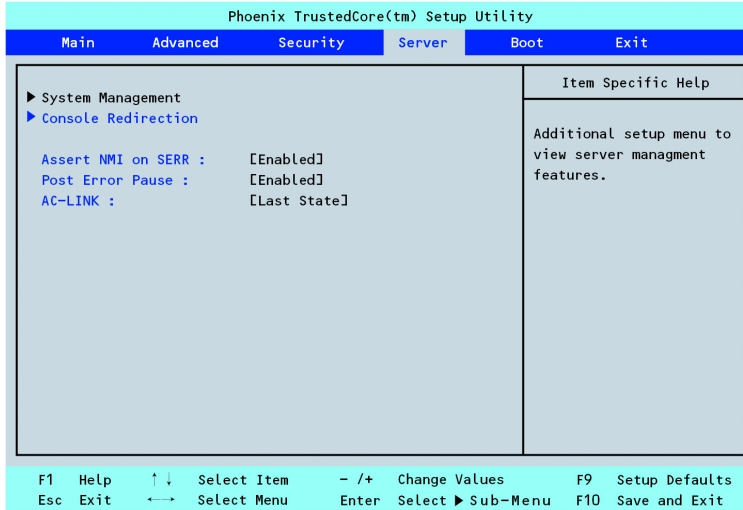

See the table below for the items.

Option	Parameter	Description	Your Setting
Assert NMI on SERR	Disabled [Enabled]	Indicates whether PCI SERR is supported or not.	
Post Error Pause	Disabled [Enabled]	Indicates whether POST is aborted once at the end of POST if an error occurs during the execution of POST.	
AC LINK	Stay Off [Last State] Power On	Specify the state of power when the AC power to the server is turned off once and then on. (See the table below.)	

[ ]: Factory-set

The table below shows the operation when the AC power to the server is turn off once and then on again, depending on the setting of "AC LINK".

System status before AC power off	Setting of AC LINK		
	Stay Off	Last State	Power On
Operating	Off	On	On
Aborting (DC power being off also)	Off	Off	On
Forced shutdown*	Off	Off	On

\* Press the power switch continuously for four seconds or longer. This forcibly turns off the power.

### IMPORTANT:

- To power on the server from the UPS (Uninterruptible Power Supply), select [Server] - [AC Link] - [Power On].
- If the server is connected to the UPS, set at least 10 seconds delay in the power-on schedule.

## System Management

The following screen appears if you select "System Management" on the Server menu and press **Enter**.

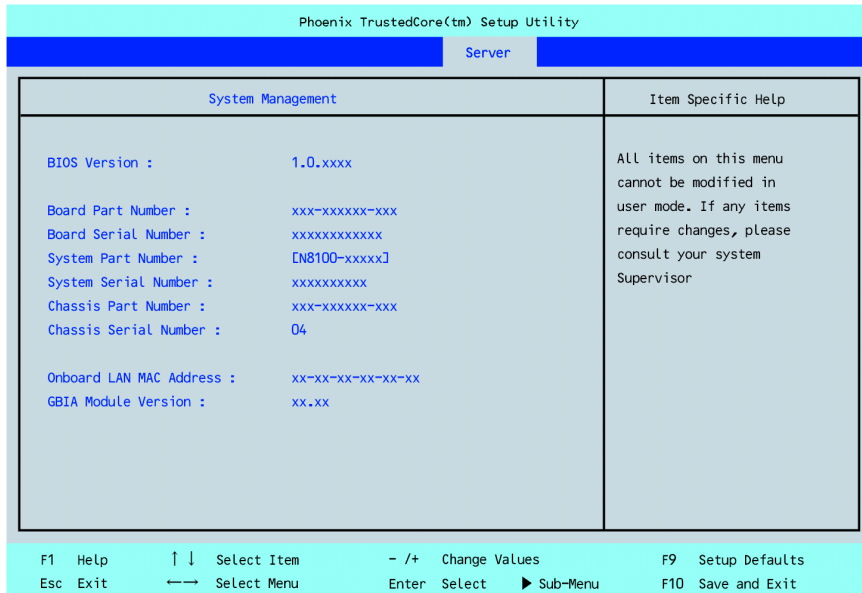

See the table below for the items.

Option	Parameter	Description	Your Setting
BIOS Version	–	Displays the current BIOS version.	
Board Part Number	–	Displays the mother board part number.	
Board Serial Number	–	Displays the mother board serial number.	
System Part Number	–	Displays the system part number.	
System Serial Number	–	Displays the System serial number.	
Chassis Part Number	–	Displays the chassis part number.	
Chassis Serial Number	–	Displays the chassis serial number.	
Onboard LAN MAC Access	–	Displays the MAC access of onboard LAN controller.	
GBIA Module Version	–	Displays the GBIA module version.	

### Console Redirection

The following screen appears if you select "Console Redirection" on the Server menu and press **Enter**.

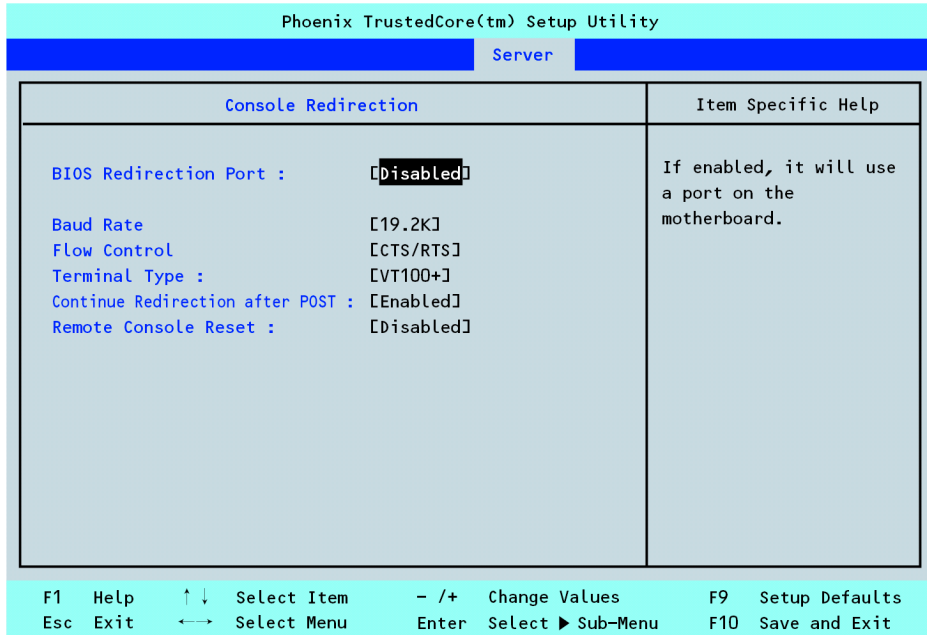

See the table below for the items.

Option	Parameter	Description	Your Setting
BIOS Redirection Port	[Disabled] Serial Port A Serial Port B	Specify the address/interrupt of the serial port to which a remote console is connected.	
Baud Rate	9600 [19.2k] 38.4k 57.6k 115.2k	Specify the baud rate used for the interface with remote consoles.	
Flow Control	None XON/XOFF [CTS/RTS] CTS/RTS+CD	Specify the flow control method.	
Terminal Type	PC ANSI [VT100+] VT-UTF8	Specify the type of remote console.	
Continue Redirection after POST	[Enabled] Disabled	Specify whether to continue console redirection feature after completion of POST.	
Remote Console Reset	[Disabled] Enabled	Specify whether to enable or disable resetting from the remote console.	

[ ]: Factory-set

## Boot

If you move the cursor to the position of "Boot", the Boot menu appears, which is used to set the boot priority.

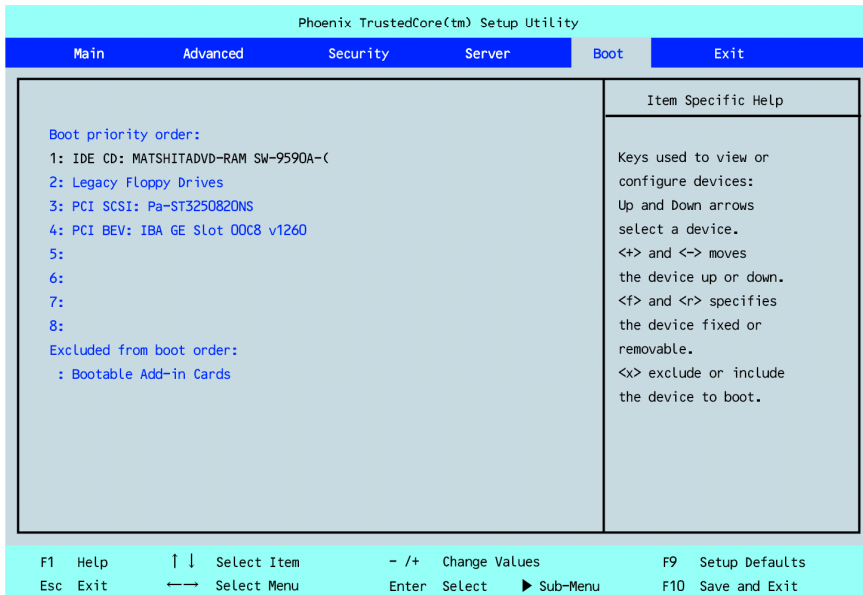

The server searches for devices in the order set in this menu on booting. Finding the boot software, the server starts the software.

Indication	Device
USB CDROM	USB CD-ROM drive
IDE CD	ATAPI CD-ROM (including factory-installed optical disk drive)
Legacy Floppy Drives	Internal floppy disk drive
USB FDC	USB floppy disk drive
USB KEY	USB flash memory device
PCI SCSI	Internal hard disk drives installed in your system
IDE HDD	IDE hard disk drives (when "Auto" for [Native Mode Operation] or "Disabled" for [SATA AHCI Enable] is specified in BIOS SETUP).
PCI BEV	<b>IBA GE Slot xxxx:</b> Onboard LAN <b>Other indication:</b> Optional PCI board

1. When BIOS detects a bootable device, it displays the information on the device in the relevant indication.

To boot the server from a desired device, the device must be registered as a boot device. (Up to eight boot devices can be registered.)

2. Pressing **X** after selecting a device allows the selected device to be registered as a boot device or deleted from the registration.

With eight boot devices being registered, any other device cannot be registered as a boot device even if you press **X**. To register a device as a boot device newly, first delete the registration of a device registered as a boot device but not booted any more.

Pressing **Shift + 1** after selecting a device allows the selected device to be made enabled/disabled.

3. You can change the boot priority (first to eighth) of each device by using **↑**, **↓**, **+** and/or **-**.

To change the priority of a device, move the cursor to the device by using the **↑** or **↓**, and press **+** or **-**.

---

**IMPORTANT:** To boot NEC EXPRESSBUILDER, set the priority of the devices as shown in the figure above.

---

## Exit

The Exit menu appears if you move the cursor to "Exit".

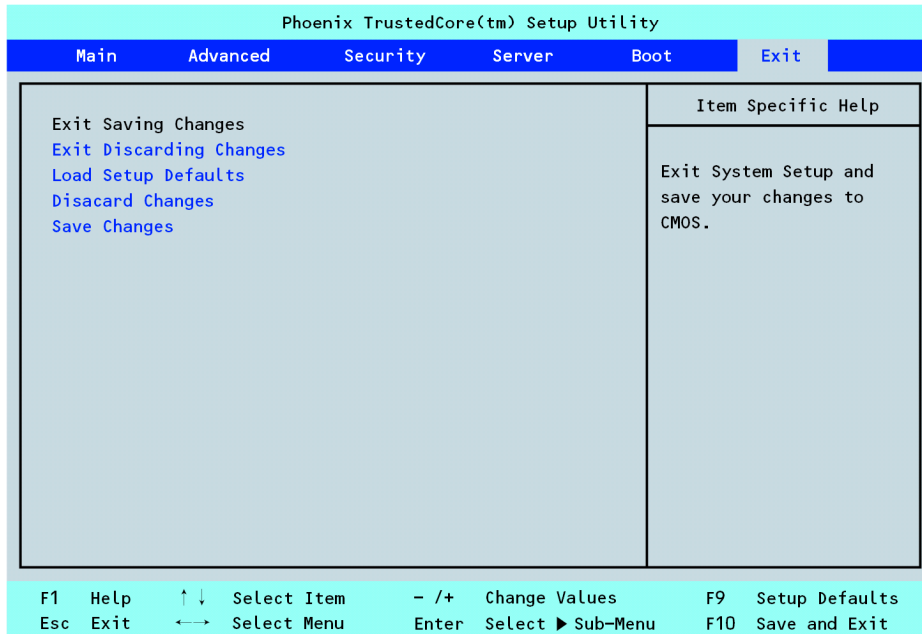

The options on the menu are described below.

### Exit Saving Changes

Select this item to terminate SETUP after saving the newly selected information in CMOS (nonvolatile memory). Selecting "Exit Saving Changes" causes the confirmation screen to appear. If you select "Yes", SETUP is terminated with the newly selected information saved in CMOS (nonvolatile memory). Then the server automatically reboots the system.

### Exit Discarding Changes

Select this item to terminate SETUP without saving the newly selected information in CMOS (nonvolatile memory). Selecting "No" allows SETUP to be terminated without storage of the modified information. Then the server automatically reboots the system. Selecting "Yes" allows SETUP to be terminated with storage of the modified information. Then the server automatically reboots the system.

### Load Setup Defaults

Select this item to return all the values of SETUP to the default values. Selecting "Load Setup Defaults" causes the confirmation screen to appear. Select "Yes" to return the values to the default values. Select "No" to return to the Exit menu screen.

**Discard Changes**

Select this item to return the values modified currently to the previous values before saving the values to CMOS.

**Save Changes**

Select this item to save the newly selected information to CMOS (non-volatile memory) without the termination of SETUP.

## CONFIGURING MOTHER BOARD JUMPERS



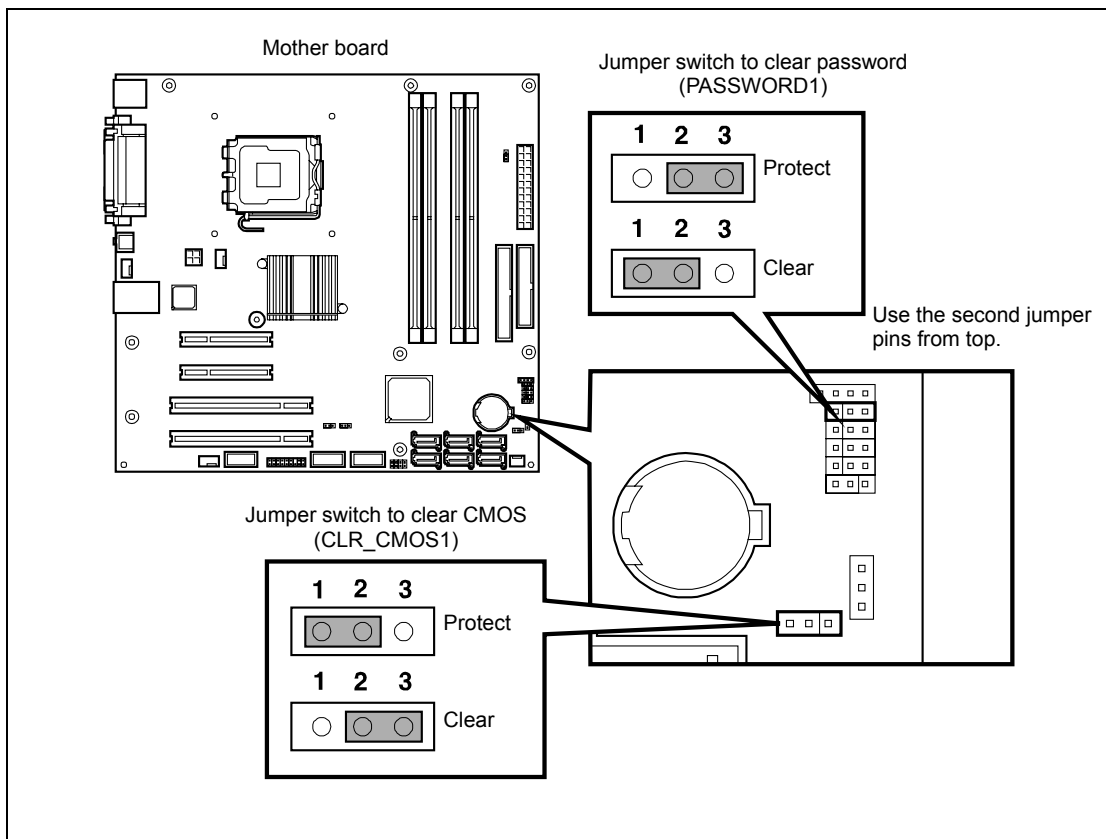

You can use the following procedure to clear the CMOS data in the server.

### IMPORTANT:

- Clearing the CMOS data resumes the factory-set configuration data.
- Do not change any other switch settings. Any change may cause the server to fail or malfunction.



The following describe the clearing procedure.

 <b>WARNING</b>	
  	<p>Do not disassemble, repair, or alter the server.</p> <p>Never attempt to disassemble, repair, or alter the server on any occasion other than described in this manual. Failure to follow this instruction may cause an electric shock or fire as well as malfunctions of the server.</p>

### Clearing CMOS Data

4. See the section "Preparing for Installation and Removal" as described in Chapter 9 of this guide to prepare.
5. Remove the left side cover (see Chapter 9).
6. Install the jumper on position 3 - 2 (CMOS clear) of the jumper block. See the figure on the previous page to find the location of this jumper.
7. After three seconds later, reinstall the jumper.
8. Reinstall the server and then turn on the power.
9. Press **F2** at the prompt to run the BIOS SETUP utility, and select "Load Setup Default" at the Exit menu.

### Clearing Password

1. See the section "Preparing for Installation and Removal" as described in Chapter 9 of this guide to prepare.
2. Remove the left side cover (see Chapter 9).
3. Check the location of jumper switch to clear the password.
4. Change jumper switch setting according to the figure on the previous page.
5. Plug the power cord to your server and turn on the server.
6. POST stops at the error message shown below.  

```
ERROR
8151 Password Cleared By Jumper

Press <F1> to resume, <F2> to Setup
```
7. Turn off the power of the server. Restore the jumper strap removed in Step 4.
8. Reassemble the server.

## **RAID SYSTEM CONFIGURATION**

This section describes how to use the internal hard disk drives as RAID System by Onboard RAID Controller (LSI Embedded MegaRAID).

About the optional RAID Controller (N8103-116/117), refer to the documents provided with optional RAID Controller.

---

### **RAID**

#### **Overview of RAID System**

##### **What is RAID (Redundant Array of Inexpensive Disks)?**

RAID is an abbreviation for "Redundant Array of Inexpensive Disks". The RAID technology allows more than one hard disk drive (HDD) to be handled collectively.

In actual, RAID can configure more than one HDDs as a single array (disk group) to operate the HDDs effectively. This can bring higher performance than a single HDD of a large capacity.

The Onboard RAID Controller (LSI Embedded MegaRAID) has a feature to divide a single disk group into several logical drives (virtual disks). The RAID controller recognizes these virtual disks as if it were a single hard disk drive. The RAID Controller accesses to more than one hard disk drive configuring a disk group in parallel.

Some RAID levels can recover data from remaining data and parity by using rebuild feature if an error occurs in a single HDD. This can provide high reliability for the system.

## RAID Levels

The record mode enabling the RAID feature includes several levels. Among the levels, the Onboard RAID Controller (LSI Embedded MegaRAID) supports RAID levels 0, 1, and 10. The number of hard disk drives required to create a disk group varies depending on the RAID level as shown in the table below.

RAID level	Number of required HDDs	
	Min.	Max.
RAID 0	1	4
RAID 1	2	2
RAID 10	4	4

---

**NOTE:** For details of the RAID levels, see "RAID Levels" described later in this chapter.

---

## Disk Group

A disk group is configured with more than one HDDs. The allowable number of disk groups is equal to the number of HDDs.

The figure below shows a sample configuration. The three HDDs are connected to the Onboard RAID Controller (LSI Embedded MegaRAID), creating one disk group (DG).

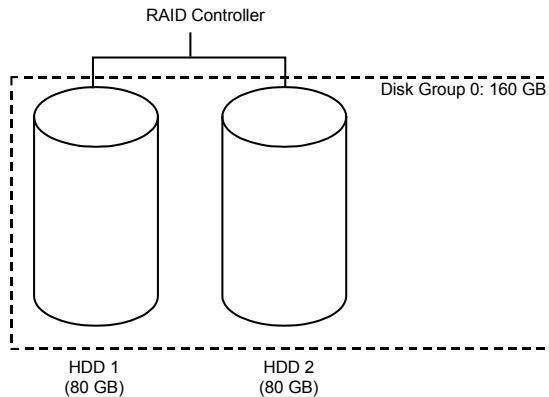

### Virtual Disk

Virtual disk is a logical drive defined in disk group. It is recognized as a physical drive by OS. The allowable number of virtual disks is up to 8 per disk group, or up to 8 per controller.

The figure below shows a sample configuration in which the Onboard RAID Controller (LSI Embedded MegaRAID) is connected with two HDDs, creating one Disk Group. Two RAID5 virtual disks (VD) are defined in the Disk Group.

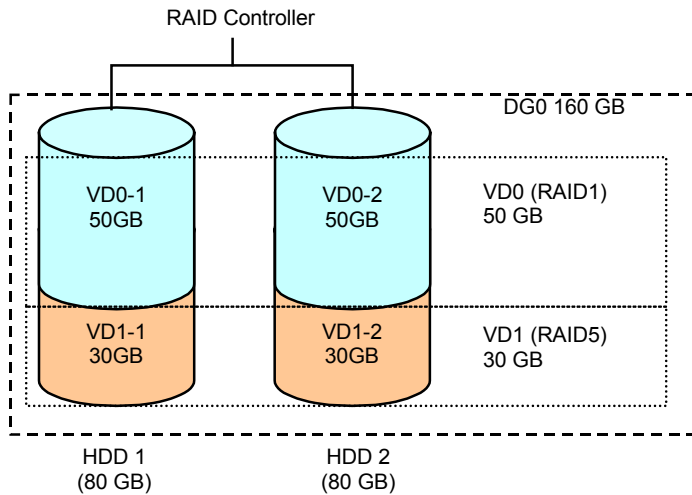

### Hot-Spare

The hot-spare is prepared as an auxiliary HDD substituting for a defected HDD included in a logical drive which is configured at a redundant RAID level. Detecting a HDD fault, the system disconnects the HDD (or makes it offline) and starts rebuild using the hot-spare.

## RAID Levels

This section describes RAID levels that the Onboard RAID Controller (LSI Embedded MegaRAID) supports. The available RAID levels are RAID0, RAID1, and RAID10 (striping of RAID1).

### Characteristics of RAID Levels

The table below lists the characteristics of the RAID levels.

Level	Function	Redundancy	Characteristics
RAID0	Striping	No	<ul style="list-style-type: none"> <li>• Data read/write at the highest rate</li> <li>• Largest capacity</li> <li>• Capacity: (capacity of single HDD) × (number of HDDs)</li> </ul>
RAID1	Mirroring	Yes	<ul style="list-style-type: none"> <li>• Two HDDs required</li> <li>• Capacity: capacity of single HDD</li> </ul>
RAID10	Striping of RAID1	Yes	<ul style="list-style-type: none"> <li>• Four or more HDDs required</li> <li>• Capacity: (capacity of single HDD) × ((number of HDDs) / 2)</li> </ul>

### RAID0

In RAID0, data to be recorded is distributed to HDDs. The mode is called "striping".

In the figure below, data is recorded in stripe 1 (disk 1), stripe 2 (disk 2), and stripe 3 (disk 3)... in the order. Because RAID0 allows all HDDs to be accessed collectively, it can provide the best disk access performance.

**IMPORTANT:** RAID0 cannot have data redundancy. If a HDD is defected, the data saved in the HDD cannot be recovered.

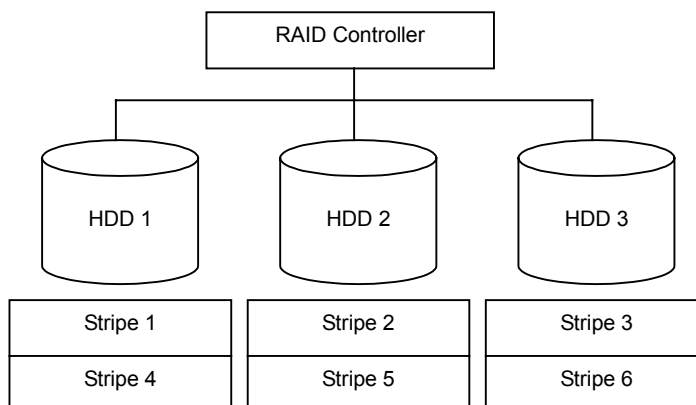

### RAID1

In the RAID1 level, data saved in a HDD is written to another HDD without change. The mode is called "mirroring".

When data is written onto a single HDD, the same data is written onto another HDD. If either of the HDDs is defected, the other HDD containing the same data can substitute for the defected HDD. Thus the system can continue to operate without interruption.

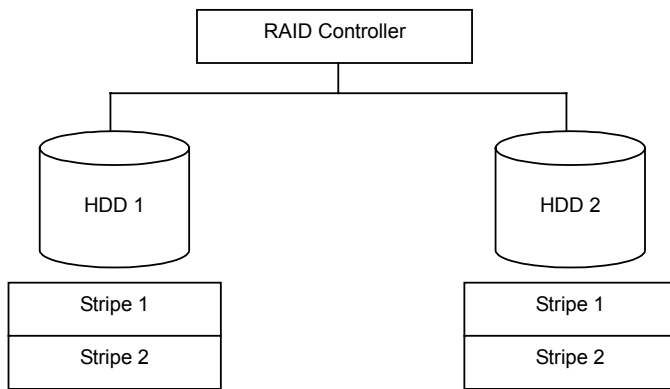

### RAID10

Data to be recorded is distributed to two HDDs in mirroring mode. Then, each mirrored data is written onto HDD by striping. Owing to this feature, high disk access performance of RAID0 and, in addition, high reliability of RAID1 can be achieved.

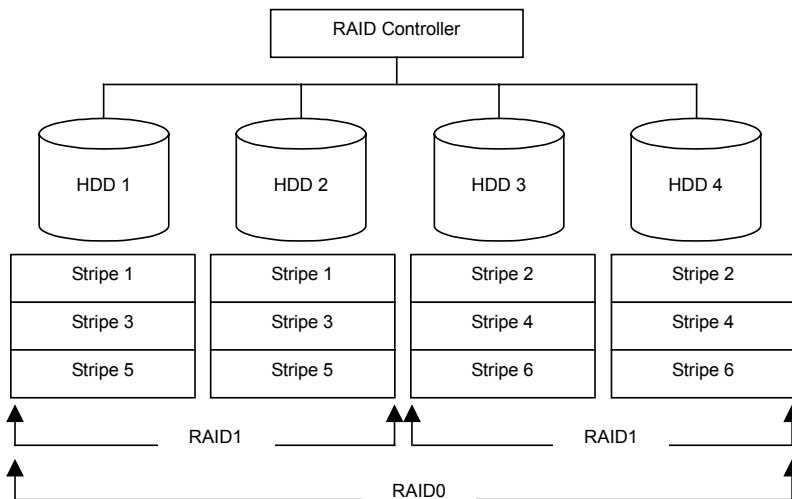

## Configuration by Onboard RAID Controller

This section describes how to use the internal hard disk drives as RAID System by Onboard RAID Controller (LSI Embedded MegaRAID).

### Installing the Hard Disk Drives

Install the required number of hard disk drives for the desired RAID level to your server. See Chapter 9 for installation procedure.

**IMPORTANT:** Use hard disk drives of the same revolution. In addition, use two hard disk drives of the same capacity if you are going to configure RAID1.

### Enabling RAID Feature

To configure a hard disk drive as RAID System, change the RAID System configuration jumper switch on mother board.

**NOTE:** The RAID System is factory-set to "Disabled".

#### ⚠ WARNING



Observe the following instructions to use the server safely. Failure to follow these instructions may result in death or serious personal injury. See pages 1-3 to 1-8 for details.

- Do not disassemble, repair, or alter the server.
- Do not remove the lithium battery.

#### ⚠ CAUTION



Observe the following instructions to use the server safely. Failure to follow these instructions may result in death or serious personal injury. See pages 1-3 to 1-8 for details.

- Make sure to complete board installation.
- Do not install the server on a rack with leaving covers removed.
- Do not pinch your finger with mechanical components.
- Note high temperature.
- Do not pull out a device from the rack if the rack is unstable.
- Do not leave more than one device being pulled out from the rack.

1. See the section "Preparing for Installation and Removal" as described in Chapter 9 of this guide to prepare.
2. Remove the left side cover (see Chapter 9).
3. Locate the position of the RAID configuration jumper on the mother board as shown below.

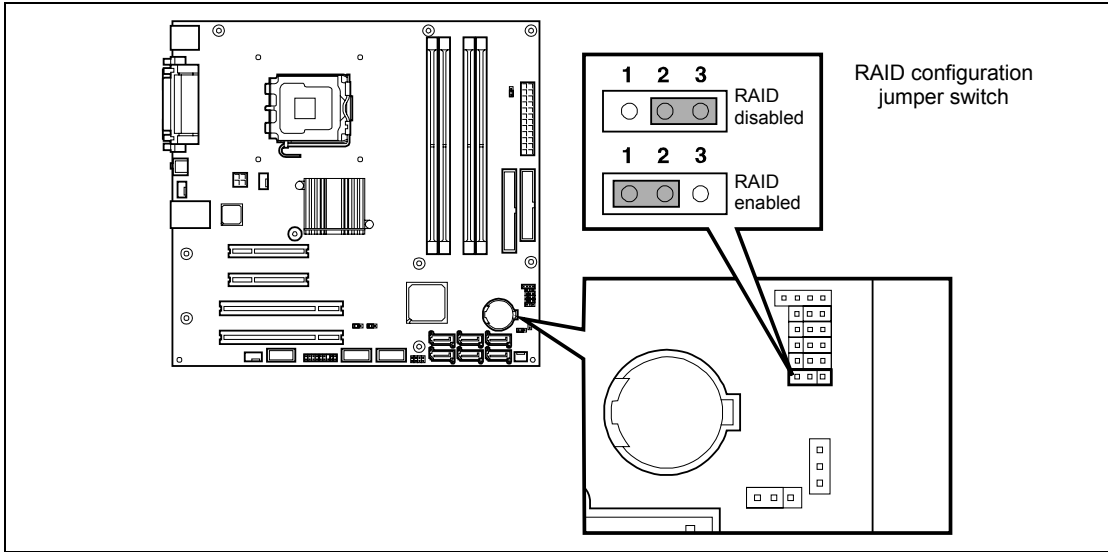

---

**NOTE:** If you are using an Optional RAID Controller, set the RAID configuration jumper switch to the position "RAID disable".

---

4. Install the duct cover removed in Step 3, and secure it with a setscrew.
5. Install the left side cover removed in Step 2.

## Setup Utility

This section describes the RAID configuration tool, LSI Software RAID Configuration Utility. This utility resides on the LSI Software RAID, therefore, its operation is independent from the operating system.

### Running LSI Software RAID Configuration Utility

1. When the following screen appears after you have powered on the server, press **Esc**.

The POST screen appears.

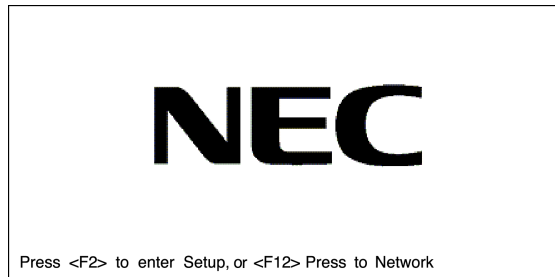

2. Check the description as shown below on the POST screen, then press **Ctrl + M**.

LSI Software RAID Configuration Utility starts.

```
LSI SoftwareRAID BIOS Version xxxxxx
LSI MPT RAID Found at PCI Bus No:xx Bev No:xx
Scanning for port 00 Responding xxxxxxxx xxxMB
Standard FW xxx DRAM=128MB(SDRAM)
xx Logical drive(s) Configured
Press <Ctrl><M> to Run LSI Software RAID Configuration Utility
```

**NOTE:** At least one hard disk drive must be connected to launch the LSI Software RAID Configuration Utility.

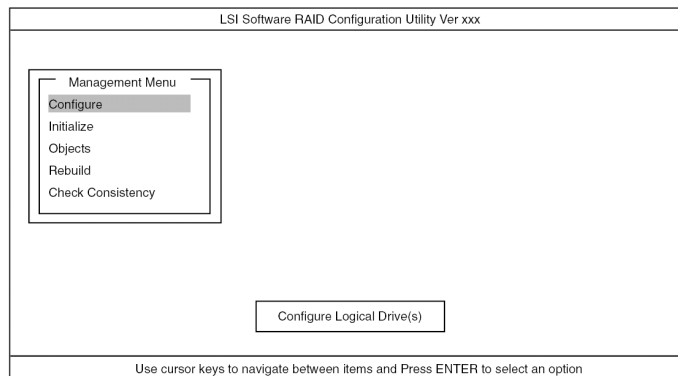

### **LSI Software RAID Configuration Utility TOP Menu (Management Menu)**

### Quitting LSI Software RAID Configuration Utility

To quit the utility, press **Esc** in the TOP menu of LSI Software RAID Configuration Utility.

When a confirmation message appears, select [Yes].

Press <Ctrl> <Alt> <Del> to REBOOT the system.

When the above message appears, press **Ctrl + Alt + Delete**.

The server is rebooted.

## Menu Tree

+ : Selection/execution parameter \* : Setting parameter. • : Information display  
> : Can be set (modified) after creation of virtual drive

Menu	Description
+Configure	Performs Configuration settings
+Easy Configuration	Set configuration (Using fixed value)
+New Configuration	Set new configuration
+View/Add Configuration	Additional setting / viewing configuration
+Clear Configuration	Clear configuration
+Select Boot Drive	Chose Bootable Virtual Drive
+Initialize	Initialize virtual drive
+Objects	Various settings
+Adapter	Set disk array controller
+Sel. Adapter	Clear configuration
*Rebuild Rate	30
*Chk Const Rate	30
*FGI Rate	30
*BGI Rate	30
*Disk WC	Off
*Read Ahead	On
*Bios State	Enable
*Cont on Error	Yes
*Fast Init	Enable
*Auto Rebuild	On
*Auto Resume	Enable
*Disk Coercion	1GB
*Factory Default	
+Virtual Drive	Virtual drive operation
+Virtual Drives	Select virtual drive (when multiple virtual drives exist)
+Initialize	Initialize virtual drive
+Check Consistency	Check virtual drive redundancy
+View/Update Parameters	Display virtual drive information
• RAID	Display RAID level
• SIZE	Display virtual drive capacity
• Stripe SIZE	Display stripe size
• #Stripes	Display the number of hard disk drives in virtual drive
• State	Display virtual drive status
• Spans	
• Disk WC	Off: Write through On: Write back
• Read Ahead	
+Physical Drive	Physical drive operation
+Physical Drive Selection Menu	Select physical drive
+Make HotSpare	Set as hot-spare disk for auto rebuilding
+Force Online	Make a disk online
+Force Offline	Make a disk offline
+Drive Properties	Display hard disk drive information
• Device Type	Hard disk drive type
• Capacity	Hard disk drive capacity
• Product ID	Hard disk drive model
• Revision No.	Hard disk drive revision
+Rebuild	Perform rebuilding
+Check Consistency	Perform virtual drive redundancy check

## Operating Procedures for Configuration Utility

### Creating/Adding Configuration

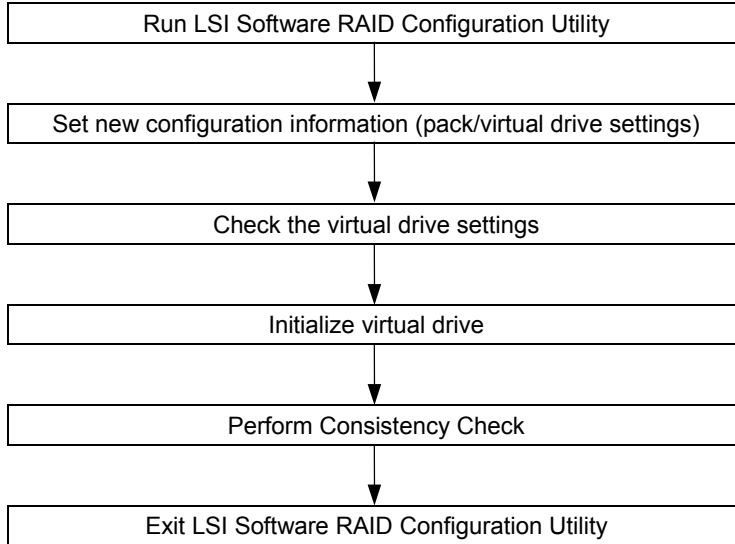

1. Run LSI Software RAID Configuration Utility.
2. Select "Configure" → "New Configuration" from the TOP menu (Management Menu).  
Select "View/add Configuration" to add configuration.

---

#### **IMPORTANT:**

- Creating a configuration using "New Configuration" menu clears the existing configuration information. To add configuration information to the existing configuration, select "View/add Configuration."
  - You cannot create Striping of RAID1 or set the virtual drive capacity on "Easy Configuration" menu.  
Use "New Configuration" or "View/Add Configuration" instead.
-

3. When a confirmation message (Proceed?) is displayed, select "Yes."

The SCAN DEVICE starts (scanning information is displayed at the bottom of the screen). Upon completion of SCAN DEVICE, the "New Configuration - ARRAY SELECTION MENU" screen appears.

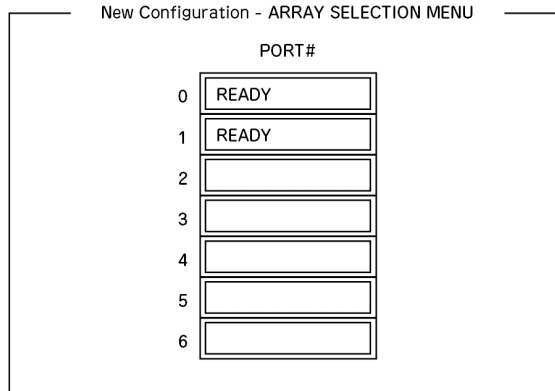

4. Move the cursor onto the hard disk drive to be packed by using cursor key and then press **Space** to select the hard disk drive.

The display for the selected hard disk drive changes from READY to ONLINE.

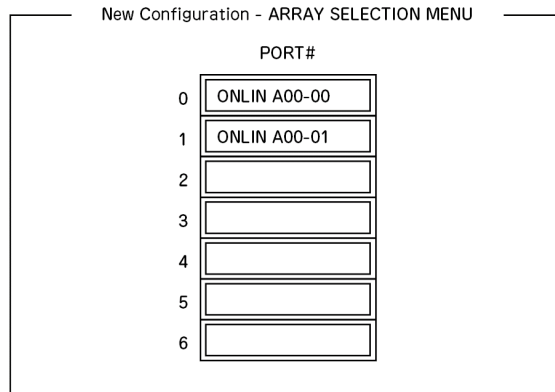

5. Press **F10** to set "Select Configurable Array(s)".

6. Press **Space**.

SPAN-1 is set.

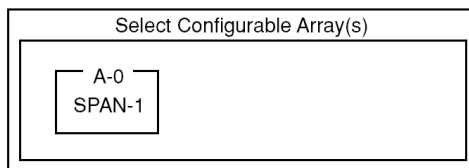

7. Press **F10** to create virtual drive.

The "Virtual Drives Configured" screen appears. (The figure below shows an example of RAID1 configured with two hard disk drives.)

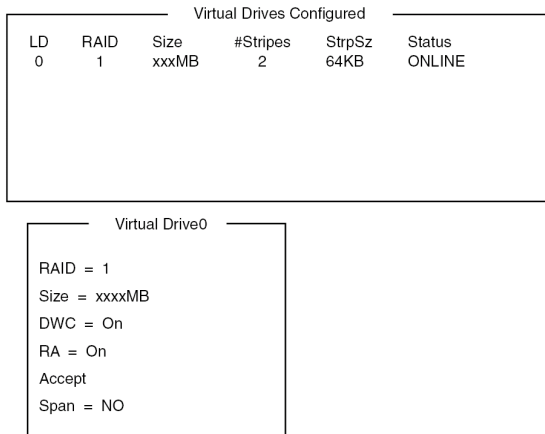

8. Select "RAID," "Size", "DWC", "RA", or "Span" by using cursor keys. Then press **Enter** to fix the selection and set each value.

(1) "RAID": Sets RAID level.

Parameter	Remarks
0	RAID0
1	RAID1
10	Striping of RAID1

The selectable RAID level varies depending on the number of hard disk drives that configure a pack.

(2) "Size": Sets virtual drive size.

Up to 8 virtual drives can be created per RAID Controller.

(3) "DWC": Sets parameter for Disk Write Cache.

Parameter	Remarks
Off	Write through
On *1	Write back

\*1 Recommended setting.

"Write-back On" enables good performance, however, cache data may be lost at an unexpected power failure. "Write-back Off" reduces performance by approximately 50%.

(4) "RA": Sets parameter for Read Ahead.

Parameter	Remarks
Off	Does not perform read ahead.
On	Performs read ahead.

(5) "Span: Sets Span.

Parameter	Remarks
SPAN=NO	Does not set span.
SPAN=YES	Sets span.

When performing SPAN, create two or more sets of the same pack at pack creation, as shown in the figure below.

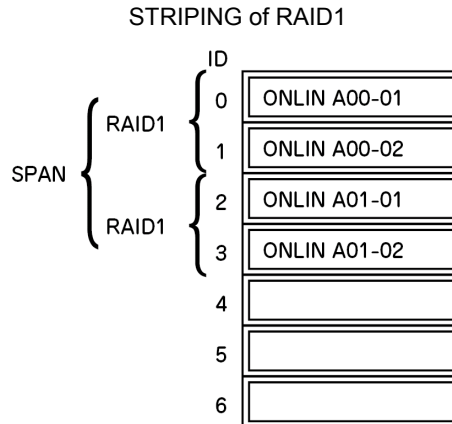

9. When all settings are completed, select "Accept" and then press **Enter** to create virtual drive.  
The created virtual drive is displayed in the "Virtual Drive Configured" screen.
10. After creating virtual drive, press **Esc** to close the screen.  
Go back to the "Save Configuration?" screen and then select "Yes" to save the configuration.
11. When the confirmation message shows that the configuration has been saved, press **Esc** to return to the TOP menu screen.
12. On the TOP menu screen, select "Objects" → "Virtual Drive" → "View/Update Parameters" to check virtual drive information.
13. Select "Initialize" in the TOP menu screen.
14. When the "Virtual Drives" screen appears, move the cursor to the virtual drive to be initialized, and press **Space**.  
The virtual drive is selected.
15. After selecting virtual drive, press **F10** to start initialization.  
A confirmation screen for execution appears. Select "Yes" to start initialization.  
When the progress bar in the "Initialize Virtual Drive Progress" screen indicates 100%, initialization is completed.

16. Execute Check Consistency on the virtual drive that has been initialized.  
See "Check Consistency" for details.
17. Press **Esc** to return to the TOP menu and exit from LSI Software RAID Configuration Utility.

---

**IMPORTANT:**

- Be sure to execute Check Consistency after creating configuration.
  - Be sure to execute Consistency Check if you have configured the RAID drives by Express Setup.
-

## Manual Rebuild

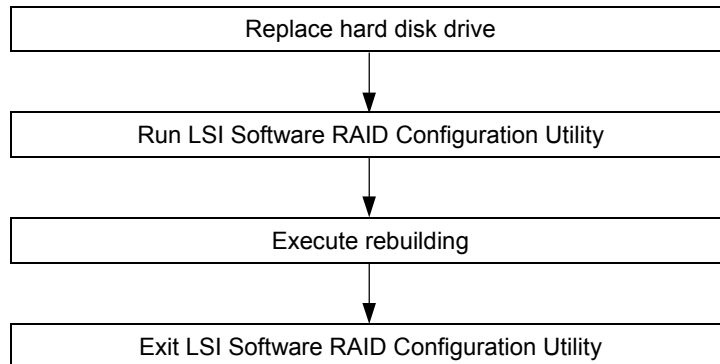

1. Replace a hard disk drive and turn on the server.
2. Run LSI Software RAID Configuration Utility.
3. Select "Rebuild" from the TOP menu.

The "Rebuild – PHYSICAL DRIVES SELECTION MENU" screen appears.

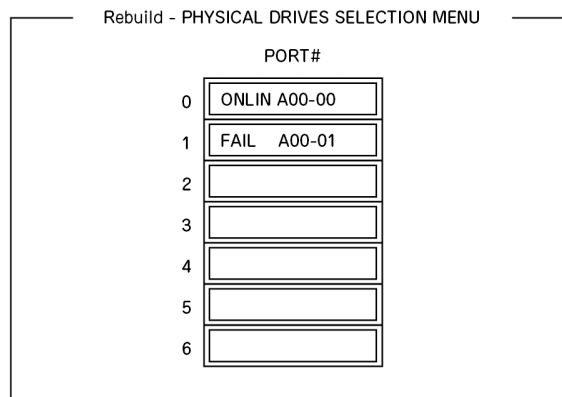

4. Move the cursor onto the hard disk drive displaying "FAIL," and then press **Space** to select it. Multiple hard disk drives can be selected (simultaneous rebuilding.)

The "FAIL" indication for the hard disk drive selected starts blinking.

5. When hard disk drive has been selected, press **F10** to start rebuilding.
6. When confirmation screen for execution appears. Select "Yes".

The rebuild process starts.

When the progress bar in the "Rebuild Physical Drives in Progress" screen indicates 100%, rebuilding is completed.

7. Press **Esc** to return to the TOP menu and exit LSI Software RAID Configuration Utility.

### Setting Hot Spare

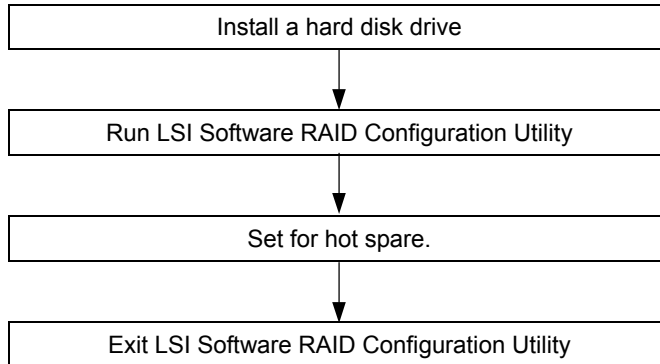

1. Install a hard disk drive to be used as hot spare, and then turn on the server.
2. Run LSI Software RAID Configuration Utility.
3. Select "Objects" → "Physical Drive" from the TOP menu.

The "Objects - PHYSICAL DRIVES SELECTION MENU" screen appears.

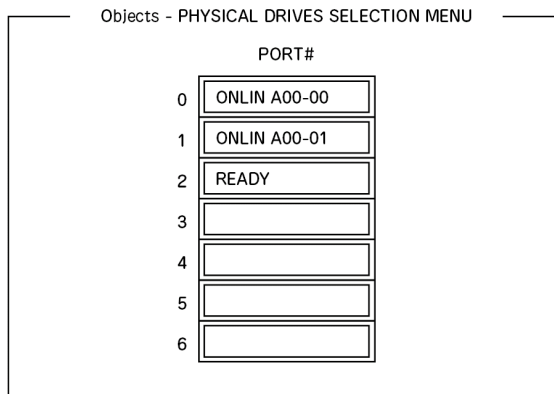

4. Move the cursor onto the hard disk drive to be used as hot spare and press **Enter**.
5. The "Port #X" screen appears. Select "Make HotSpare."
6. A confirmation screen appears. Select "Yes."

The hard disk drive indication is changed to "HOTSP."

7. Press **Esc** to return to the TOP menu and exit LSI Software RAID Configuration Utility.

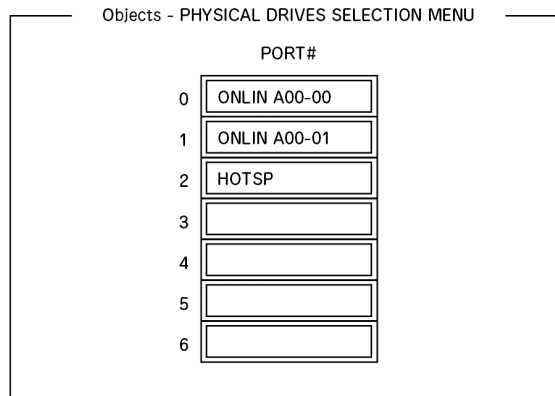

---

**IMPORTANT:**

- Select "Objects" → "Physical Drive" → "Port #X" → "Force Offline" to cancel the hot spare setting.
  - When two or more hard disk drives (of the same capacity) are assigned as hot spare, rebuilding is performed in order starting from the one with the smaller CH number/ID number.
-

### Check Consistency

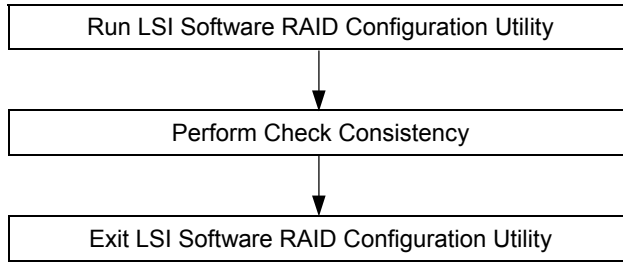

1. Run LSI Software RAID Configuration Utility.
2. Select "Check Consistency" from the TOP menu.  
The "Virtual Drives" screen appears.
3. Move the cursor onto the virtual drive to be checked, and press **Space** to select it.
4. When virtual drive has been selected, press **F10** to start consistency check.
5. A confirmation screen for execution appears. Select "Yes".  
The consistency check starts.  
When the progress bar in the "Check Consistency Progress" screen indicates 100%, the consistency check is completed.
6. Press **Esc** to return to the TOP menu and exit LSI Software RAID Configuration Utility.

---

#### IMPORTANT:

- Be sure to execute Check Consistency after creating configuration.
  - Be sure to execute Consistency Check if you have configured the RAID drives by Express Setup.
-

## Others

- Clear Configuration

Clears configuration information. Select "Configure" → "Clear Configuration" from the TOP menu. Executing "Clear Configuration" clears all configuration information on the RAID Controller and hard disk drives. The configuration information on all channels of the RAID Controller is also cleared.

---

### NOTES:

- When configuration information on the RAID Controller and that on the hard disk drive do not match (excluding at replacement of faulty RAID Controller), configuration may fail if you select the configuration information on the RAID Controller. In this case, execute "Clear Configuration" to create configuration again.
  - LSI Software RAID Configuration Utility cannot delete each virtual drive. Use Universal RAID Utility instead.
- 

- Force Online

Puts a hard disk drive being in the FAIL status online.

Select "Objects" → "Physical Drive" → (select hard disk drive) → "Force Online" from the TOP menu.

- Rebuild Rate

Sets the Rebuild Rate.

Select "Objects" → "Adapter" → "Sel. Adapter" → "Rebuild Rate" from the TOP menu.

Available value is between 0% and 100%. Default value (recommended) is 30%.

- Hard disk drive information

Checks hard disk drive information.

Select "Objects" → "Physical Drive" → (select hard disk drive) → "Drive Properties" from the TOP menu.

---

## LSI Software RAID Configuration Utility and Universal RAID Utility

You can use Universal RAID Utility for configuration and management, monitoring of RAID System after start up operating system.

The point to keep in mind when I use Universal RAID Utility together with LSI Software RAID Configuration Utility is as follows.

### Terms

LSI Software RAID Configuration Utility and Universal RAID Utility are different in term. When you use Universal RAID Utility together with LSI Software RAID Configuration Utility, please convert terms by the following list.

Term of LSI Software RAID Configuration Utility	Term of Universal RAID Utility
Adapter	RAID Controller
Logical Drive	Logical Drive
Array	Disk Array
Physical Drive	Physical Device

### Number and ID

The number to manage each component of disk array of Universal RAID Utility is different to LSI Software RAID Configuration Utility.

### Adapter and RAID Controller

LSI Software RAID Configuration Utility manages Adapter by a number beginning with 0. You can see a number of Adapter where [Sel. Adapter] in [Objects] menu. Universal RAID Utility manages RAID Controller by a number beginning with 1. You can see a number of RAID Controller where [Number] in the property of RAID Controller on RAID Viewer.

Also, you can see the number of Adapter managed by LSI Software RAID Configuration Utility where [ID] in the property of RAID Controller by Universal RAID Utility.

### Logical Drive

LSI Software RAID Configuration Utility manages Logical Drive by a number beginning with 0. You can see a number of Logical Drive where [Logical Drives] in [Objects] menu.

Universal RAID Utility manages Logical Drive by a number beginning with 1. You can see a number of Logical Drive where [Number] in the property of Logical Drive on RAID Viewer.

Also, you can see the number of Logical Drive managed by LSI Software RAID Configuration Utility where [ID] in the property of Logical Drive by Universal RAID Utility.

## Disk Array

LSI Software RAID Configuration Utility manages Disk Array by a number beginning with 0. You can see a number of Disk Array where [Axx] of [Objects - PHYSICAL DRIVE SELECTION MENU] DG X] in [Objects] menu.

Universal RAID Utility manages Disk Array by a number beginning with 1. You can see a number of Disk Array where [Disk Array] in the property of Logical Drive on RAID Viewer.

## Physical Drive and Physical Device

LSI Software RAID Configuration Utility manages Physical Drive by ID. You can see ID of Physical Drive where [Port #] of [Objects - PHYSICAL DRIVE SELECTION MENU] DG X] in [Objects] menu.

Universal RAID Utility manages Physical Device by a number beginning with 1 and ID. The ID is same value of ID on LSI Software RAID Configuration Utility. You can see a number and ID of Physical Device where [Number] and [ID] in the property of Physical Device on RAID Viewer.

## Setting of Priority

LSI Software RAID Configuration Utility displays and sets Rebuild Priority and Consistency Check Priority of RAID Controller by percentage. But, Universal RAID Utility uses three levels as High/Middle/Low for them.

The setting value of LSI Software RAID Configuration Utility and the display level of Universal RAID Utility

Item	Setting value of LSI Software RAID Configuration Utility	Universal RAID Utility Level
Rebuild Priority	15 to 100	High
Rebuild Rate (LSI Software RAID Configuration Utility)	8 to 14	Middle
	0 to 7	Low
Consistency Check Priority	15 to 100	High
Chk Const Rate (LSI Software RAID Configuration Utility)	8 to 14	Middle
	0 to 7	Low

The setting level of Universal RAID Utility and the setting value

Item	Setting level of Universal RAID Utility	Setting value
Rebuild Priority Rebuild Rate (LSI Software RAID Configuration Utility)	High	90
	Middle	50
	Low	10
Consistency Check Priority Chk Const Rate (LSI Software RAID Configuration Utility)	High	90
	Middle	50
	Low	10

---

**NOTES:**

- LSI Software RAID Configuration Utility can set FGI Rate (Foreground Initialize) and BGI Rate (Background Initialize Priority). But Universal RAID Utility can't set it.
  - Universal RAID Utility can set Initialization Priority, but it can't set it to the LSI Embedded MegaRAID. Therefore, Universal RAID Utility doesn't display [Initialization Priority] in the property of RAID Controller.
-

# Chapter 5

---

## Installing the Operating System with Express Setup

This section describes information on using Express Setup to install and configure the following operating systems to the server.

- Microsoft® Windows® Server 2003 Standard Edition
- Microsoft® Windows® Server 2003 R2 Standard Edition

To use the server with the other operating systems described in this section, contact your service representative.

---

**IMPORTANT:** Before installing the operating system, adjust the system date and time by using the BIOS setup utility "SETUP." See Chapter 4 for detail.

---

## About Express Setup

"Express Setup" helps you to install the Windows Operating System. The setup automatically configures the RAID system and installs the Operating System and some management software.

---

**IMPORTANT:** Executing the Express Setup erases all data on the hard disk drive.

---

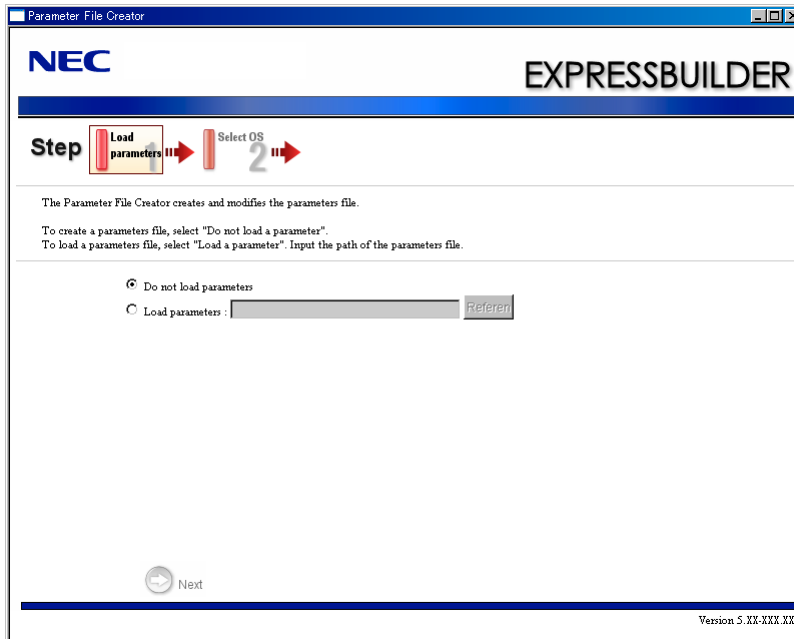

You can also use "Parameter File" at "Express Setup" in order to save or backup parameters for installation.

If you want to set up the server as before, execute the Express Setup with the parameter file you have saved before.

---

### NOTES:

- If you want to create a parameters file, have a blank floppy disk (MS-DOS 1.44MB format) ready.
  - When using a floppy disk, a USB floppy disk drive is required.
  - If you want to use the drivers located on the "OEM-Disk for Mass Storage Device" that ships with optional boards, a parameters file is mandatory.
  - You can create a parameters file in advance using "Parameter File Creator" included in NEC EXPRESSBUILDER.
-

## Microsoft Windows Server 2003

This section explains how to install Microsoft® Windows® Server 2003 by using the Express Setup.

---

**IMPORTANT:** Be sure to prepare Windows Server 2003 CD-ROM that includes Service Pack 1.

---

---

### NOTES:

- Express Setup does not support the installation of Windows Server x64 Editions. If you want to install it, see Appendix D.
  - If you install Windows Server 2003 without using Express Setup, see Appendix E.
- 

---

## Notes on Windows Installation

This section explains the notes on the Windows installation.

Confirm these notes before starting the Express Setup.

### About the Windows family

This computer supports the following Windows editions:

- Microsoft® Windows® Server 2003 Standard Edition (hereinafter, referred to as "Windows Server 2003")
- Microsoft® Windows® Server 2003 R2 Standard Edition (hereinafter, referred to as "Windows Server 2003")

---

**NOTE:** Express Setup does not support the installation of Windows Server 2003 x64 Editions. If you want to install it, see Appendix D.

---

On installing other OS, contact sales dealer or the maintenance service representative.

### BIOS Settings

Confirm the BIOS settings described in Chapter 4 before installing Windows Server 2003.

### **Service Pack Which EXPRESSBUILDER Supports**

The EXPRESSBUILDER DVD attached to the server supports the following combination of the OS installation media and Service Pack.

- Windows Server 2003 R2 x64 Edition
  - OS installation media (with Service Pack 2)
  - OS installation media (No Service Pack) + Service Pack 2
  - OS installation media (No Service Pack)
- Windows Server 2003 R2
  - OS installation media (with Service Pack 2)
  - OS installation media (No Service Pack) + Service Pack 2
  - OS installation media (No Service Pack)
- Windows Server 2003
  - OS installation media (with Service Pack 1)
  - OS installation media (with Service Pack 1) + Service Pack 2

## Optional Board Supported by NEC EXPRESSBUILDER

NEC EXPRESSBUILDER attached to this computer supports the following optional boards:

---

**NOTE:** If you want to install the other boards except ones listed below by using a driver floppy disk ("OEM-FD for Mass storage device"), see "Exceptional setup" and "Installing Optional Mass Storage Driver" of "Parameter File Creator" in Chapter 6.

---

- Controllers supporting installation of OS with Express Setup
    - N8103-116 RAID controller (128 MB, RAID0/1)
    - N8103-117 RAID controller (128 MB, RAID0/1/5/6)
    - LSI Embedded MegaRAID™ (embedded on the mother board)
  - Other controllers
    - N8103-75 SCSI Controller\*
    - N8103-95 SCSI Controller\*
    - N8103-107 SCSI Controller\*
- \* Option

---

### NOTES:

- The driver of option card mentioned above is stored in the EXPRESSBUILDER DVD.
  - If you use the board not mentioned above, the ExpressSetup will fail. Refer to the instructions attached to the board.
- 

## About the Hardware Components

When you install the Windows Server 2003, Express Setup requires several preparations if this computer uses the following hardware components.

### Installing on the Mirrored Volume

If you want to install the Windows Server 2003 on the volume that is mirrored using "Disk Management", invalidate the mirroring and set back to the basic disk before the installation, and validate the mirroring again after the installation.

You can create, invalidate or delete the mirror volume by using "Disk Management" in "Computer Management".

### Mounting MO Device

Do not mount an MO device on this computer during the Windows installation.

### About Removable Media

Do not set removable media, such as DAT, into the device mounted on this computer during the Windows installation.

### Connecting Hard Disk Drive

Do not connect the other hard disk drives except the drive that you want to create the Windows system drive.

If you create multiple logical drives in your system, see "Re-installing the Operating system when multiple logical drive exist" (Appendix E).

### Re-installing to the hard disk drive which has been upgraded to Dynamic Disk

You cannot re-install Windows Server 2003 with the current partition of the hard disk drive upgraded to Dynamic Disk kept remained.

If you want to keep the current partition remained, see Appendix E to re-install the system.

## About the System Partition Size

The system partition size can be calculated from the following formula.

Size necessary to install the system	+ Paging File Size + Dump File Size + Application Size
Size necessary to install the system	= 3500MB (Windows Server 2003 R2) = 3500MB (Windows Server 2003 with Service Pack1) = 3500MB (Windows Server 2003 R2 with Service Pack2) = 5300MB (Windows Server 2003 R2 + ServicePack 2 CD-ROM) = 5300MB (Windows Server 2003 with Service 1 + ServicePack 2 CD-ROM)
Paging File Size (Recommended)	= Mounted Memory Size * 1.5
Dump File Size	= Mounted Memory Size + 12MB
Application Size	= Required Size

---

### IMPORTANT:

- The above-mentioned paging file size is recommended for collecting debug information (memory dump). The paging file with initial size large enough to store the dump file in the boot drive is required.  
Correct debug information might not be able to be collected due to virtual memory shortage when the paging file is insufficient, so set an enough size of the paging file with the entire system.
  - The maximum paging file size which can be set on one partition is 4095MB. If the above paging file size exceeds 4095MB, specify 4095MB for the paging file size.
  - The maximum dump file size for the system with more than 2GB memory mounted is '2048MB + 12MB'.
  - If you install any application program or the like, add necessary space to the partition to install these programs.
- 

For example, if the mounted memory size is 512MB, the partition size will be calculated by the above formula as follows:

$$3500\text{MB} + (512\text{MB} * 1.5) + (512\text{MB} + 12\text{MB}) + \text{Application Size} \\ = 4792\text{MB} + \text{Application Size}$$

Dividing into the partition of the recommended size into multiple disks as written below will solve problem that it cannot be reserved in one disk.

1. Set the "Size required for installation + Paging file size".
2. See Chapter 5 and set that debugging information (equivalent to the dump file size) is to be written to a separate disk.

(If the disk does not have enough free space to enable the dump file size to be written, then after installing the system using the "Size required for installation + Paging file size", install an additional new disk.)

### **Installing the Service Pack**

When installing Windows Server 2003 R2, it is not necessary to install the Service Pack 1.

## FLOW OF SETUP

This section visually describes the flow of the setup operated by Express Setup.

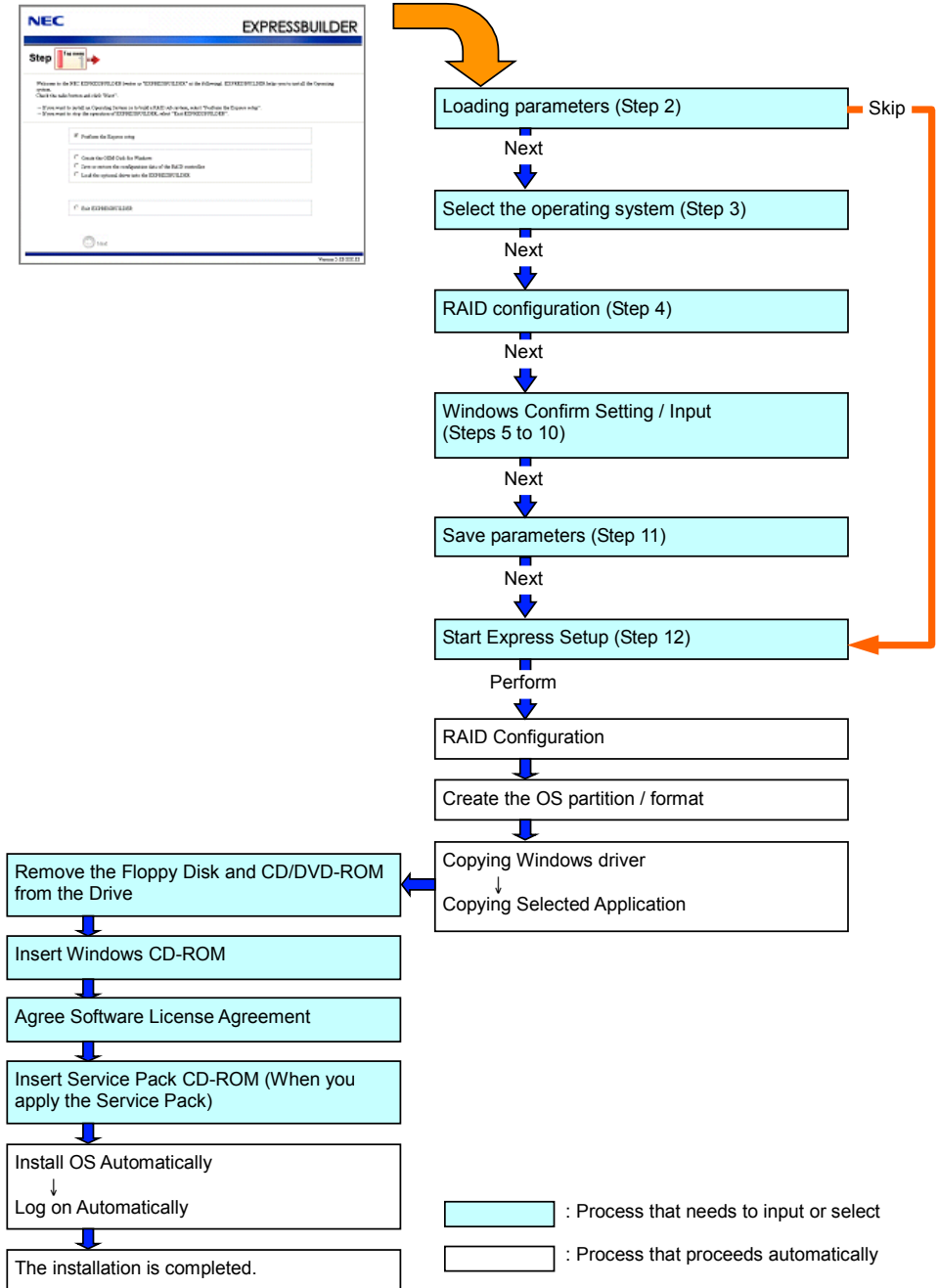
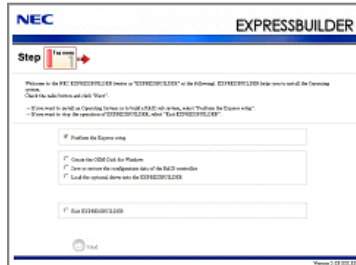

## Installing the Windows Server 2003

Express Setup proceeds the setup by selecting or inputting several parameters on the wizard. You can also save the parameters to a floppy disk as a parameters file.

1. Turn the power of peripheral device on, and then turn on the server.
2. Insert the NEC EXPRESSBUILDER DVD into the optical disk drive of the server.
3. Press the RESET switch or press **Ctrl, Alt, and Delete** to reboot from the NEC EXPRESSBUILDER. (You may also turn off and then on again to reboot the server.)

The system will boot from the DVD-ROM and NEC EXPRESSBUILDER starts.

Select "OS installation \*\*\* default \*\*\*" from the boot selection menu. (If you do not hit any key, "OS installation" is selected automatically.)

The Top menu will appear.

4. Select [Perform the Express setup] from the Top Menu, click [Next].

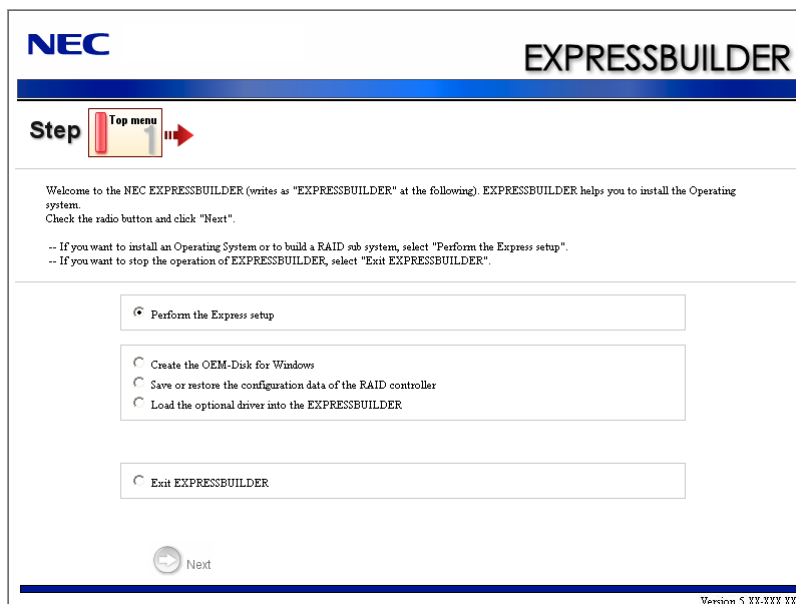

5. [Load parameters] steps are displayed.

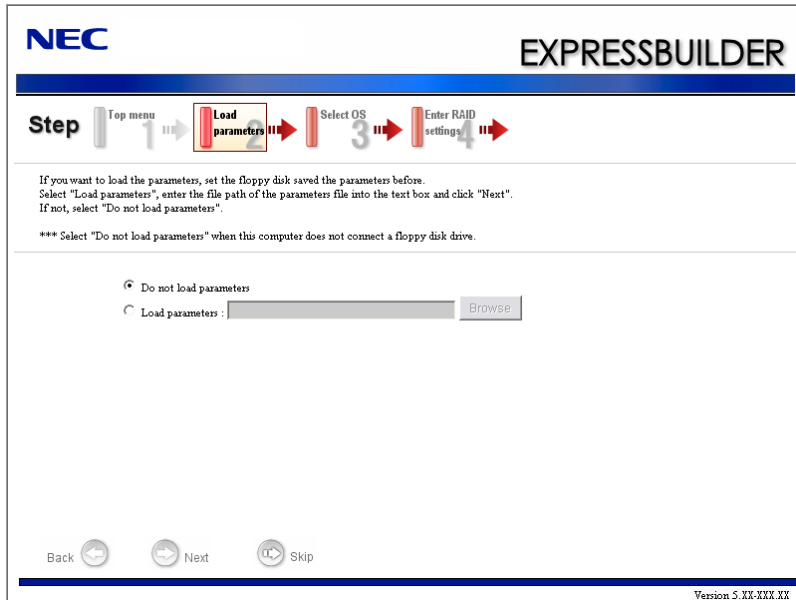

[Do not load parameters]

- (1) Select [Do not load parameters].
- (2) Click [Next].

---

**NOTE:** If a floppy disk drive is not connected, select this item.

---

[Load parameters]

- (1) Insert the floppy disk containing the parameters file.
- (2) Select [Load parameters], enter the file path of the parameters file into the text box.
- (3) Click [Next].

6. Select the installing Operating System.

Select [Install the Windows (32bit editions)] from the menu, click [Next].

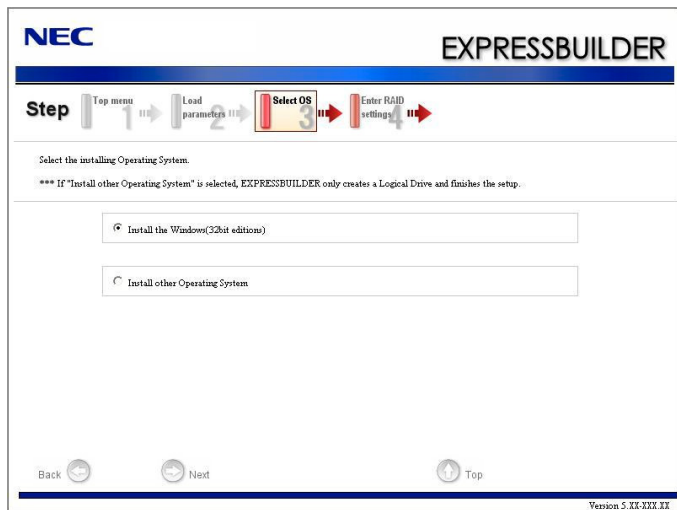

7. Enter the setting of a logical drive.

[Enter RAID settings] steps are displayed. Confirm the parameters, modify if necessary, and then click [Next].

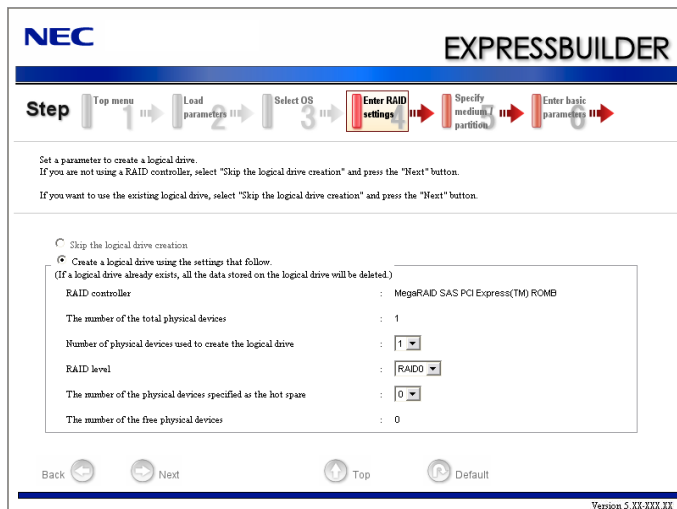

**NOTES:**

- You can use only the physical devices that have same model number to configure logical drive.
- If the process is not finished normally, the driver may not be stored in the EXPRESSBUILDER. See "Optional Board Supported by NEC EXPRESSBUILDER" described earlier in this chapter.

8. Specify the installing medium and the Windows system partition.

[Specify medium / Partition] steps are displayed. Confirm the parameters, modify if necessary, and then click [Next].

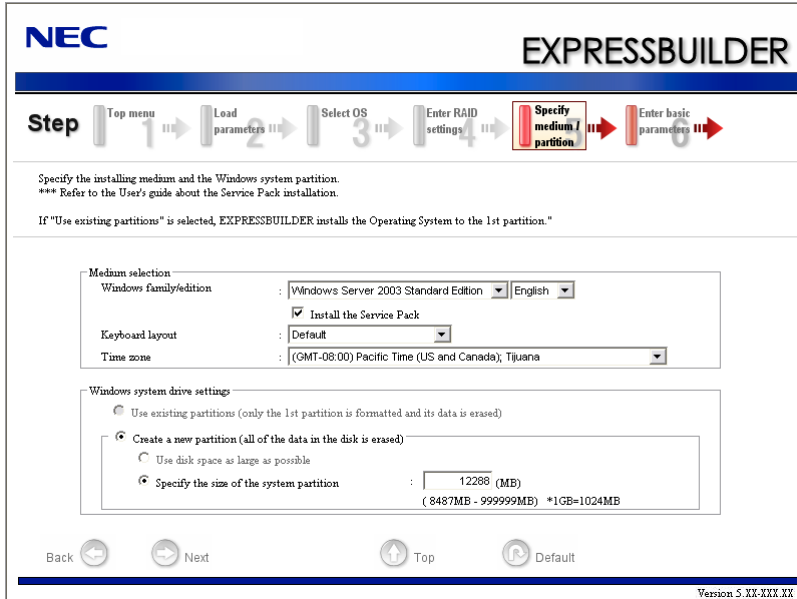

**IMPORTANT:**

- About partition size
  - Specify the partition size larger than required minimum size for OS installation.
  - Do not specify larger partition size than the capacity of connected hard disk drive.
  - You can not specify the partition size larger than 2,097,152MB (2TB) at RAID system.
- If you select "Create a new partition" at "Windows system drive settings", the contents of the hard disk will be all deleted.
- If "Use existing partitions" is selected, EXPRESSBUILDER installs the Operating System to the 1st partition (1st partition is deleted). The data in the other partition is kept if the system has two or more partitions. (See the figure below.)

First Partition Deleted	Second Partition Retained	Third Partition Retained
-------------------------	---------------------------	--------------------------

- You can not re-install the system with the existing partition that is upgraded to Dynamic Disk remained. Do not select "Use existing partitions" at "Windows system drive settings".

9. Enter the user information and client license mode.

[Enter basic parameters] steps are displayed. Confirm the parameters, modify if necessary, and then click [Next].

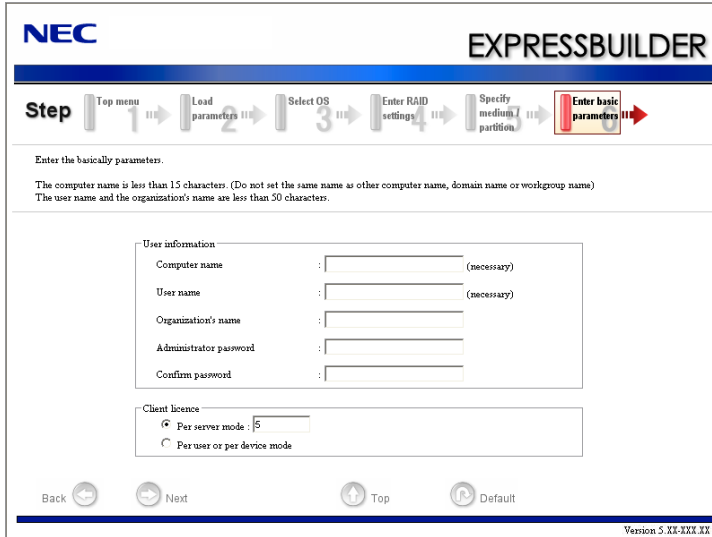

**NOTE:** Even if you do not input value into "Administrator password", "Confirm password", "???????" is displayed.

10. Enter the setting of the network protocol.

[Enter Network Protocol] steps are displayed. Confirm the parameters, modify if necessary, and then click [Next].

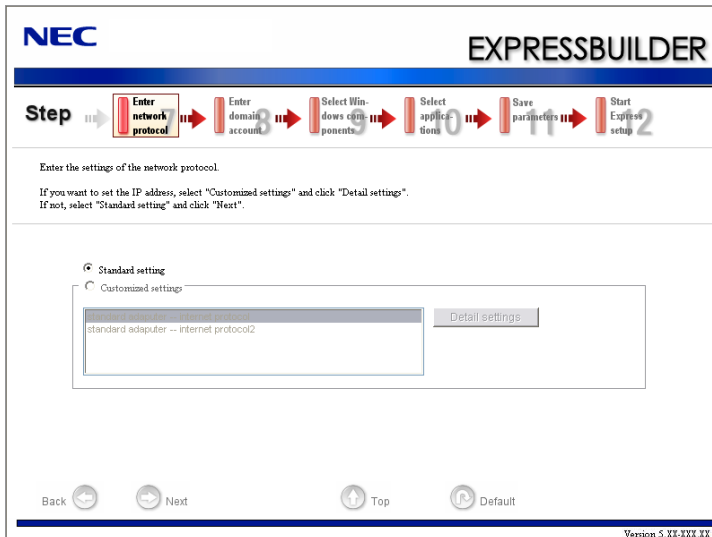

11. Enter the domain or workgroup name to be used.

[Enter domain account] steps are displayed. Confirm the parameters, modify if necessary, and then click [Next].

**NEC EXPRESSBUILDER**

Step 7 Enter network protocol 8 Enter domain account 9 Select Windows components 10 Select applications 11 Save parameters 12 Start Express setup

If you want to join in a domain, enter the account name/password of the domain.  
If not, select "Join in a workgroup" and click "Next".

Join in a workgroup  
Workgroup name : WORKGROUP

Join in a domain  
Domain name :  
Account name :  
Password :  
Confirm password :

Back Next Top Default

Version 5.XX-XXX.XX

12. Select the installing components.

[Select Windows components] steps are displayed. Confirm the parameters, modify if necessary, and then click [Next].

**NEC EXPRESSBUILDER**

Step 7 Enter network protocol 8 Enter domain account 9 Select Windows components 10 Select applications 11 Save parameters 12 Start Express setup

Select the installing Windows components.

Application Server  
 Internet Information Services(IIS) [Detail settings](#)

Management and Monitoring Tools  
 Simple Network Management Protocol [Detail settings](#)  
 Network Monitor Tools

Networking Services  
 Simple TCP/IP Services  
 Dynamic Host Configuration Protocol(DHCP)  
 Domain Name System(DNS)  
 Windows Internet Name Services(WINS)

Other Network File and Print Services  
 File Services for Macintosh  
 Print Services for Macintosh  
 Print Services for Unix

Back Next Top Default

Version 5.XX-XXX.XX

**13.** Select the installing applications.

[Select applications] steps are displayed. Confirm the parameters, modify if necessary, and then click [Next].

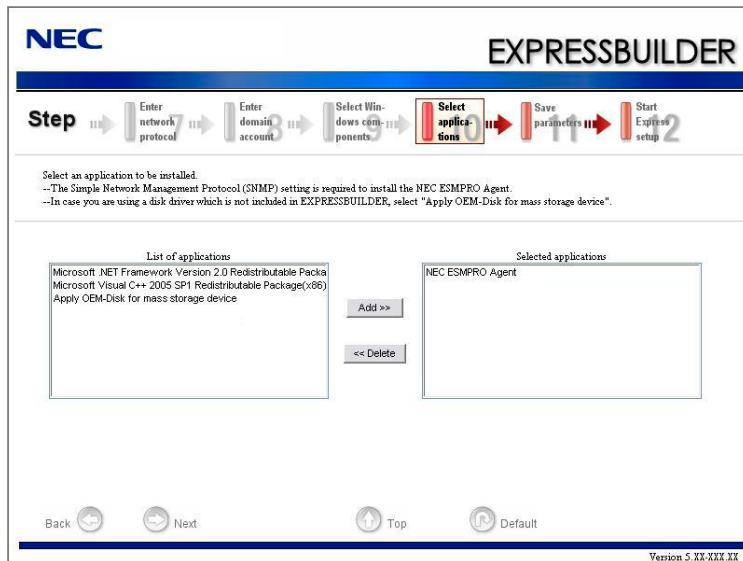

**14.** Save the parameters.

[Save parameters] steps are displayed.

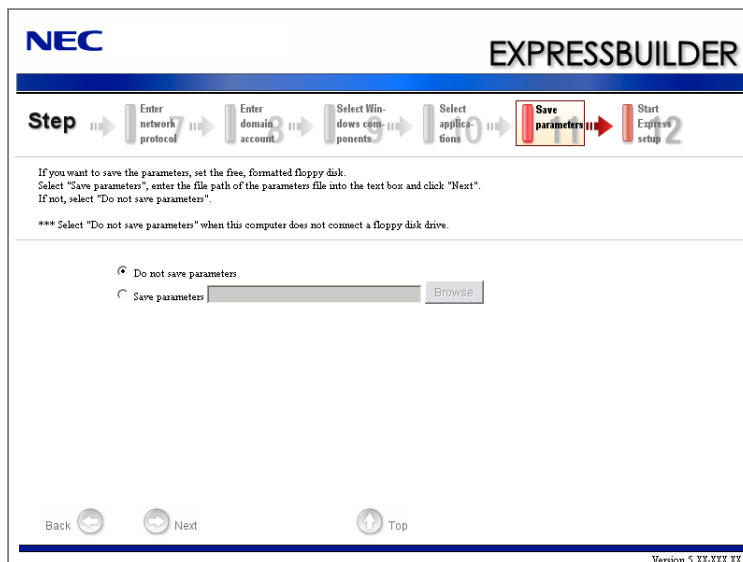

If you want to save the parameters , set the free formatted floppy disk.

Select [Save parameters], enter the file path of the parameters files into the text box and click [Next].

If not, select [Do not save parameters].

15. The Express Setup will start when you click [Perform] in [Start Express setup] step.

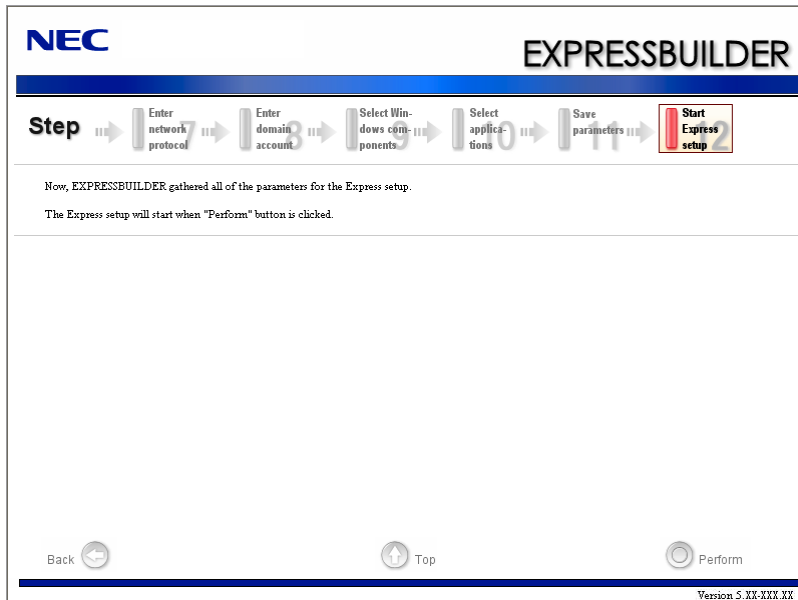

16. Copy optional Mass Storage Driver module.

If you install optional Mass Storage Driver, the message will be shown.

Insert CD-ROM or floppy disk attached to the Mass Storage Driver and proceed operation according to the message.

17. Remove NEC EXPRESSBUILDER DVD from the optical disk drive according to the message.

If you proceed the setup by using setup parameter file, remove the floppy disk from the floppy disk drive.

Insert Windows Server 2003 CD-ROM into the optical disk drive.

[Agree Software License Agreement] screen appears.

18. Read the contents carefully and click [Yes] if you do agree. If you do not agree, click [No].

---

**IMPORTANT:**

- If you do not agree to this agreement, the setup terminates and Windows Server 2003 will not be installed.
  - If "NetWare Gateway (and Client) Service" is specified to install, the window to specify the details of "NetWare Gateway (and Client) Service" pops up on the first logon. Specify the appropriate value.
-

- 19.** If you selected [Install the Service Pack] at [Specify Medium Partition] step, follow the procedure below.
- 1) Follow the message to take Windows Server 2003 CD-ROM out of the optical disk drive.
  - 2) Follow the message to insert Windows Server 2003 Service Pack 2 into the optical disk drive.

**IMPORTANT:** If you install Windows CD-ROM that contains Service Pack 2 to your system, you do not have to apply Service pack 2 again.

Windows Server 2003 and selected applications will be installed automatically and rebooted several times. After rebooting, it logs on to the system automatically.

- 20.** If you install Microsoft Windows Server 2003 R2, insert Microsoft Windows Server 2003 R2 Standard Edition DISC 2 into the optical disk drive after the OS installation.

Hereinafter, proceed operations according to the message.

When the installation has finished, remove Microsoft Windows Server 2003 R2 Standard Edition DISC 2 from the optical disk drive, and restart the system.

Now the Setup using Express Setup has completed.

---

## Installing and Setting Device Drivers

Follow these steps to install and configure the device drivers.

### PROSet

PROSet is a utility that confirms the function of network contained in network driver.

Utilizing PROSet enables the following items:

- Confirm detailed information of the adapter.
- Diagnose loop back test, packet transmission test and so on.
- Setup of teaming.

Configuring several network adapters as one team provides the server a tolerant environment on any trouble and enhances throughput between the switches.

PROSet is necessary to utilize these features.

---

**NOTE:** All of the operation that related to Intel® PROSet must be execute by administrator privileges. Operation by [Remote Desktop Connection] is prohibited.

Without changing any parameter when opened the properties of adapter teaming, please click the [Cancel] button for close the dialog.

Click [OK] button will cause temporary loss of network connectivity.

---

Follow the procedure below to install PROSet.

- 1.** Insert the NEC EXPRESSBUILDER DVD into the optical disk drive.  
If the autorun menu is displayed, close menu screen.
- 2.** The [Windows Explorer] dialog starts.
  - \* The procedure in the case of the standard start menu  
Click Start menu and click [Windows Explorer].
  - \* The procedure in the case of the classic start menu  
Click Start menu, point to [Programs], [Accessories] and click [Windows Explorer].
- 3.** Run "dxsetup.exe" in the following directory.  
\\006\win\winnt\dotnet\dl3\proset\win32  
The [Intel(R) PROSet - InstallShield Wizard] dialog starts.
- 4.** Click [Next].
- 5.** Choose "I accept the terms in the license agreement" and click [Next].
- 6.** Click [Next].
- 7.** Choose "I accept the terms in the license agreement" and click [Next].
- 8.** Click [Install].
- 9.** When [InstallShield Wizard Completed] window is displayed, click [Finished].
- 10.** Remove the NEC EXPRESSBUILDER DVD from the optical disk drive, restart the system.

## Adapter Fault Tolerance (AFT)/Adaptive Load Balancing (ALB)

Adapter Fault Tolerance (AFT) is a feature that creates a group containing more than one adapter and automatically converts the process of the working adapter to the other adapter in the group when any trouble occurred on that adapter.

Adaptive Load Balancing (ALB) is a feature that creates a group containing more than one adapter and enhance the through put by operating packet transmission from the server by all the adapters.

This feature includes AFT feature.

---

### IMPORTANT:

- AFT/ALB setup must be operated after installing the drivers and restarting the system.
  - All the adapters specified as a group of Adapter Teaming must exist on the same LAN. If they are connected to the separate switches, they will not work normally.
  - The adapters specified as a group of Adaptive Load Balancing (ALB) can be connected to only Switching Hub.
  - When exchange the mother board or option network card, make sure to remove the adapter team before exchanges and recreate the adapter team after exchange complete.
- 

If you want to utilize AFT/ALB feature, follow the procedure below to setup.

1. The [Intel (R) PROSet] dialog box appears.
  - \* The procedure in the case of the standard start menu  
Click Start menu, point to [Control Panel], [administrative tools], and click [Computer Management] and then double click the [(Network Adapter Name)] in the Network Adapter list.
  - \* The procedure in the case of the classic start menu
    1. Click Start menu, point to [Settings] and click [Control Panel].
    2. Click [administrative tools].
    3. Click [Computer Management] and double click the [(Network Adapter Name)] in the Network Adapter list.
2. Select [Teaming] tab and then check on [Team with other adapters] and click [New Team...].

The [New Team Wizard] dialog box appears. Click [Next].

  - \* Specify a name for the team if it necessary.
3. Select the adapters to include in team.
4. Select "Adapter Fault Tolerance" or "Adaptive Load Balancing" and click [Next].
5. Click [Finish].

6. If necessary to set the adapter priority setting, refer the following step. If not, go through to step 7.
  1. Click [Settings] tab on [TEAM:xxx #yy Properties].
  2. Click [Modify Team].
  3. Point to the adapter [Intel(R)PRO/1000....]and click [Set Primary] or [Set Secondary].
  4. Click [OK].
  5. The setup will go back to [EAM:xxx #yy Properties] and the priority setting will display in list ().
  6. Click [OK].
7. The setup will go back to [Intel (R) PROSet for Wired Connections]dialog box, so click [OK].
8. Restart the system.

## Network Driver

Specify the details of network driver.

One standard network driver that is mounted will be installed automatically, but the link speed and Duplex mode need to be specified manually.

IP addresses is not be able to set when the "Internet Protocol (TCP/IP)" check box OFF.

This phenomenon will occur with the certain condition.

Check ON the "Internet Protocol (TCP/IP)" check box and IP address will be able to set.

[When PROSet is not installed]

1. The [Local Area Connection Properties] dialog box appears.
  - \* The procedure in the case of the standard start menu
    1. Click Start menu, Click [Control Panel], Click [Network Connections], and Click [Local Area Connection].
  - \* The procedure in the case of the classic start menu
    1. Click Start menu, Click [Settings] and Click [Network Connections].  
The [Network Connections] dialog box appears.
    2. Right-click [Local Area Connection] and click [Properties] from pop-up menu.
2. Click [Configure].  
The property dialog box for network adapter appears.
3. Click the [Advanced] and specify the [Link Speed & Duplex] value the same as the value specified for HUB.
4. Click [OK] on the property dialog box for network adapter.

[When PROSet is installed]

1. The [Intel(R) PROSet] dialog box appears.
  - \* The procedure in the case of the standard start menu  
Click Start menu, point to [Control Panel], [administrative tools], and click [Computer Management] and then double click the [(Network Adapter Name)] in the Network Adapter list.
  - \* The procedure in the case of the classic start menu
    1. Click Start menu, point to [Settings] and click [Control Panel].
    2. Click [administrative tools].
    3. Click [Computer Management] and double click the [(Network Adapter Name)] in the Network Adapter list.
2. Click the [Link] and specify the [Speed and Duplex] value the same as the value specified for HUB.
3. Click [Apply] and click [OK].

Also, add or delete any protocols and services if necessary.

You can operate the process on the property dialog box for local area network which can be appeared from [Network and Dial-up Connection].

---

**NOTE:** We recommend you to add [Network Monitor] at [Adding Services]. [Network Monitor] can monitor the frame (or the packet) that the computer installing [Network Monitor] sends or receives. This tool is valuable when analyzing network trouble. For information on how to install the tool, see the "Setting for Solving Problems" described later in this chapter.

---

## Optional Network Board Driver

If you want to utilize optional Network Board (N8104-112/119/111/120/121/125/126), the network driver will be installed automatically. Therefore, the driver attached to the Network board should not be used.

If you want to utilize optional Network Board, install the driver stored in NEC EXPRESSBUILDER DVD.

In case of utilizing (N8104-111)

"\006\win\winnt\dotnet\dl3\pro100\win32"

In case of utilizing (N8104-112/119/120/121/125/126)

"\006\win\winnt\dotnet\dl3\pro1000\win32"

## Installation of the Optional Network Board Driver

1. Start Device Manager.
2. Click [Network adapters] and Double-click [(Network Adapter Name)].  
[(Network Adapter Name) Properties] appears.

---

**NOTE:** [(Intel(R) PRO/1000...)] is the name of On-Board adapter. All other names show the Optional Network Board.

---

3. Click [Driver] tab and click [Update Driver...]. [Hardware Update Wizard] appears.
4. Select the [Install from a list or specific location(Advanced)] radio button and click [Next].
5. Select the [Search for the best driver in these locations] radio button and check off the [Search removable media (floppy, CD-ROM...)] check box.
6. Check the [Include this location in the search] check box and when using [(N8104-111)], specify  
[\006\win\winnt\dotnet\dl3\pro100\win32].  
Then click [Next].  
When using [(N8104-112/119/120/121/125/126)], specify  
[\006\win\winnt\dotnet\dl3\pro1000\win32].  
Then click [Next].
7. Click [Finish].

## Graphics Accelerator Driver

If you utilize standard graphics accelerator drivers, update your system with NEC EXPRESSBUILDER DVD attached to your system.

Standard graphics accelerator drivers will be installed automatically.

Please follow the following procedure when you want to re-install the driver individually.

- 1.** Insert the NEC EXPRESSBUILDER DVD into the optical disk drive.  
If the autorun menu is displayed, close menu screen.
- 2.** Click Start menu, point to [Programs], [Accessories] and click [Windows Explorer].
- 3.** Run "setup.exe" in the following directory.  
\\006\win\winnt\dotnet\video\setup.exe
- 4.** Follow the message to continue the installation.  
If the dialog message "Digital Signature could not been found." appears, select [Yes] to continue.
- 5.** Remove the NEC EXPRESSBUILDER DVD from the optical disk drive, restart the system.

## Installing SCSI Controller Driver (N8103-75/95/107)

If you utilize SCSI controller driver (N8103-75/95/107), update your system with NEC EXPRESSBUILDER DVD attached to your system.

The SCSI controller driver will be installed automatically.

---

## Setting for Solving Problems

Setup the following issue in advance so that your computer can recover from any trouble precisely and as soon as possible when it should occur.

### Memory Dump (Debug Information)

This section describes the procedures for collecting memory dump (debug information) in the server.

---

**IMPORTANT:** Cautions for the Memory Dump

- The staff of maintenance service representative is in charge of collecting memory dump. Customers need only to specify the memory dump.
  - If any trouble occur after specifying the process below, the message to inform that the system is in short of virtual memory may appear, but continue to start the system. If you restart the system in such case, memory dump may not be stored correctly.
- 

Follow the procedure below to specify.

1. Select [Control Panel] and click [System].  
The [System Properties] dialog box appears.
2. Select [Advanced] tab.
3. Click [Settings] on the [Startup and Recovery] group box.

---

**IMPORTANT:**

Windows Server 2003 x64 Editions

- To specify "Complete Memory Dump" to write the debug information is recommended.  
If the mounted memory size is larger than 2GB, "Complete Memory Dump" cannot be specified so that specify "Kernel Memory Dump" instead.
- Specify the drive where there is a free area more than the size of "the memory capacity mounted on Express server + 1MB".
- In case the mounted memory size exceeds 2GB due to the added memory, change the write debugging information to [Kernel Memory Dump] before adding memory. The size of debugging information (memory dump) to be taken also changes due to adding memory. Verify the size of the empty space in the debugging information (memory dump) write destination drive.

Windows Server 2003

- To specify "Complete Memory Dump" to write the debug information is recommended.  
If the mounted memory size is larger than 2GB, "Complete Memory Dump" cannot be specified so that specify "Kernel Memory Dump" instead.
  - Specify the drive where there is a free area more than the size of "the memory capacity mounted on Express server + 12MB" (In case the memory capacity is more than 2GB, a free area of "2048+12MB" or more).
  - In case the mounted memory size exceeds 2GB due to the added memory, change the write debugging information to [Kernel Memory Dump] before adding memory. The size of debugging information (memory dump) to be taken also changes due to adding memory. Verify the size of the empty space in the debugging information (memory dump) write destination drive.
-

4. Specify "Complete memory dump" and modify [Dump file:] in the [Write debugging information] group box.  
e.g. Write the debug information in D drive write the file name "MEMORY.DMP".  
D:\MEMORY.DMP
5. Click [Settings] on the [Performance] group box.  
The [Performance Options] window appears.
6. Click [Advanced] tab on the [Performance Options] window.
7. Click [Change] on the [Virtual memory] group box.
8. Modify [Initial Size] in the [Paging file size for selected drive] box to the value larger than the value of [Recommended] in the [Total paging file size for all drives], and click [Set].

---

**IMPORTANT:**

- The above-mentioned paging file size is recommended for collecting debug information (memory dump). The paging file with initial size large enough to store the dump file in the boot drive is required.  
Correct debug information might not be able to be collected due to virtual memory shortage when the paging file is insufficient, so set an enough size of the paging file with the entire system.
  - For more information on "Recommended" value, see "About the System Partition Size" described earlier.
  - In case the memory is expanded, re-specify the paging file to suit the new memory size.
- 

9. Click [OK].

The message to restart the system may appear according to the modified specification. In such case, follow the message to restart the system.

## Windows Dr. Watson

Windows Dr. Watson is a debugger for application errors. If any application error is detected, Dr. Watson diagnoses the server and logs diagnostic information (log). Follow the procedure below and specify Dr. Watson to collect diagnostic information.

1. Click [Run] on Start menu.
2. Type "drwtsn32.exe" in the [Open] box, and click [OK].  
The [Dr. Watson for Windows] dialog box appears.
3. Specify the location to store the diagnostic information in the [Log File Path] box.  
The diagnostic information will be stored with the file name "DRWTSN32.LOG".

---

**NOTE:** You can not specify network path. Specify the path on local computer.

---

4. Specify the location of crash dump file in the [Crash Dump] box.

---

**NOTE:** "Crash Dump File" is a binary file that can be read with Windows Debugger.

---

5. Check the following check box on the [Option] box.

- Dump Symbol Table
- Dump All Thread Contexts
- Add To Existing Log File
- Create Crash Dump File

For more information on each function above, refer to Online Help.

6. Click [OK].

## Network Monitor

Utilizing Network Monitor helps you to investigate and manage with network trouble. To utilize Network Monitor, you need to restart the system after the installation has completed, so we recommend to install Network Monitor before any network trouble may occur.

1. Point to [Settings] from Start menu and click [Control Panel].  
The [Control Panel] dialog box appears.
2. Double-click [Add or Remove Programs].  
The [Add or Remove Programs] dialog box appears.
3. Click [Add/Remove Windows Component].  
The [Windows Components Wizard] dialog box appears.
4. Click [Management and Monitoring Tools] and then click [Details].  
The [Management and Monitoring Tools] dialog appears.
5. Click to select the [Network Monitor Tools] check box, and then click [OK].
6. The [Windows Components Wizard] dialog box appears again, so click [Next].
7. If the setup asks to install the disk, insert the OS CD-ROM into optical disk drive and click [OK].
8. Click [Finish] in the [Windows Component Wizard] dialog box.
9. Close the [Add or Remove Programs] dialog box.
10. Close the [Control Panel] dialog box.

To start Network Monitor, point to [Program] → [Administrative Tools] and click [Network Monitor]. For information on how to operate Network Monitor, refer to Online Help.

---

## Installing Maintenance Utilities

Various maintenance utilities are contained in your NEC EXPRESSBUILDER DVD. See Chapter 6 for installing the utilities to your server or management workstations.

---

## Updating the System – Installing Service Pack –

---

**IMPORTANT:** If you install Windows Server 2003 CD-ROM which contains Service Pack 2 to your system, you do not have to apply Service Pack 2 again.

---

"Updating the System" is executed by Express Setup automatically.

Execute "Updating the System" in following cases.

- Processor is expanded (expanded to single processor to multi-processor).
- Modified system configuration.
- Recovered the system using recovery process.

See "Updating the System - Applying Service Pack -" section in Appendix D for detail of update process.

---

## **Making Backup Copies of System Information**

The system information includes the current BIOS settings and any specific information for the server.

Save the information after completing the system setup.

Without the backup data, you will not be able to recover the information.

You can save the information by the following process.

1. Insert the NEC EXPRESSBUILDER DVD into the optical disk drive and reboot the system.
2. Select [Tool menu (Normal mode)].
3. Select [English].
4. Select [Maintenance Utility].
5. Select [System Information Management].
6. Insert a floppy disk into the floppy disk drive.
7. Select [Save].

---

## Installing with the OEM-FD for Mass Storage Device

This section explains how to setup with the OEM-FD. You usually do not have to do as follows. The detailed information is provided by the manual of the Mass Storage Device.

### Installation of Mass storage device not to be supported by ExpressSetup

If you would like to install or re-install the OS when the system has new mass storage device not to be supported by NEC EXPRESSBUILDER, you have to set as follows.

1. Read the manual supplied with the mass storage device before setting the server.
2. If the mass storage device is RAID Controller, configure the RAID system before running the NEC EXPRESSBUILDER.
3. Boot the system from NEC EXPRESSBUILDER DVD.
4. Select [Load the optional driver into the EXPRESSBUILDER] from the Top menu, click [Next].

Setting the driver disk for the mass storage controller.

Press the "Perform" button.

---

**NOTE:** By choosing this option, you can load the driver provided by CD-ROM or floppy disk to proceed with the Express Setup.

---

5. Perform Express Setup with the following settings.
  - (a) When "Enter RAID settings" appears, check "Skip the logical drive creation".
  - (b) Select "Apply OEM-Disk for Mass storage device".
6. Copy the driver for the mass storage device in the Express Setup.

Insert the floppy disk attached the mass storage device into the floppy disk drive.

Continue the Express Setup, referring to messages displayed on the display.

# Chapter 6

---

## Installing and Using Utilities

This section describes how to use the NEC EXPRESSBUILDER DVD that comes with your server and to install the utilities stored on the NEC EXPRESSBUILDER.

## NEC EXPRESSBUILDER

The NEC EXPRESSBUILDER (referred to as "EXPRESSBUILDER" hereinafter) helps you install the Operating system/the Management software or use the maintenance utilities.

When you insert the EXPRESSBUILDER disk into the optical disk drive and reboot the system, the following menu appears.

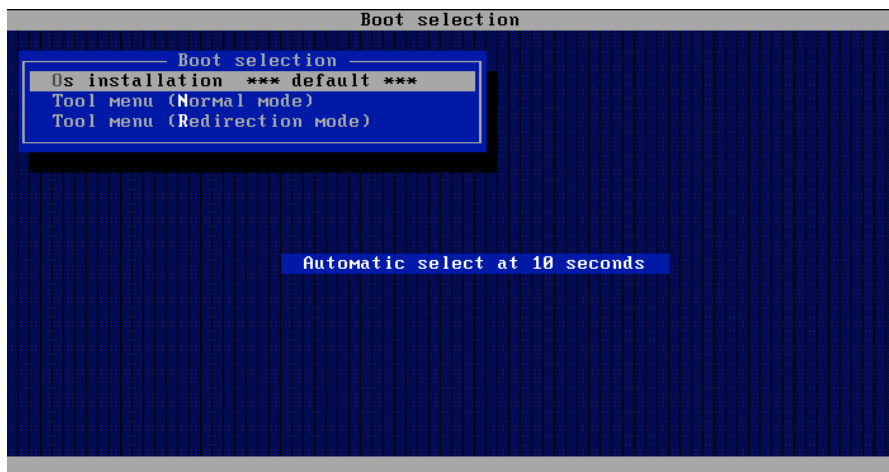

- OS installation

If you select this item, the Top menu appears.

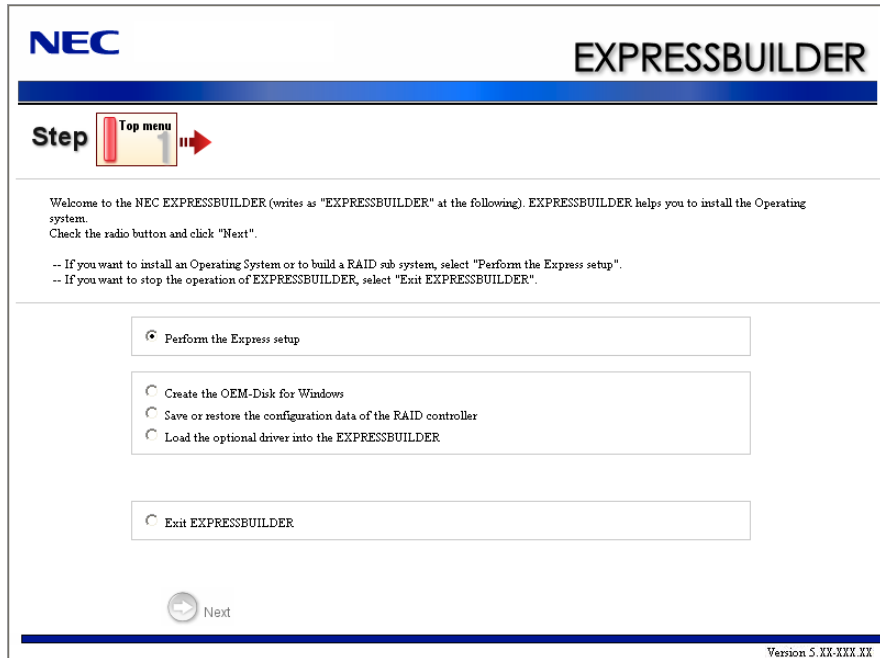

---

**IMPORTANT:**

- This tool is Configuration Tool that built on Windows PE 2.0 technology.  
Pay attention to the automatic reboot that occurs after 72 hours from start.
  - The configuration with Windows PE 2.0 supports Windows Server 2003 (32bit) and Windows Vista Business (32-bit (x86)), but the other operation is not supported.
- 

You can use the Express Setup (see Chapter 5) or the following functions from this menu.

- Create the OEM-Disk

You can create the Windows OEM-Disk to use at the Windows manual setup.

- Load the driver

This function is not usually used. If you add the new device to the server, this function may use. (See Chapter 5.)

■ Tool menu (Normal Mode)

If you select this item, the Tool menu appears.

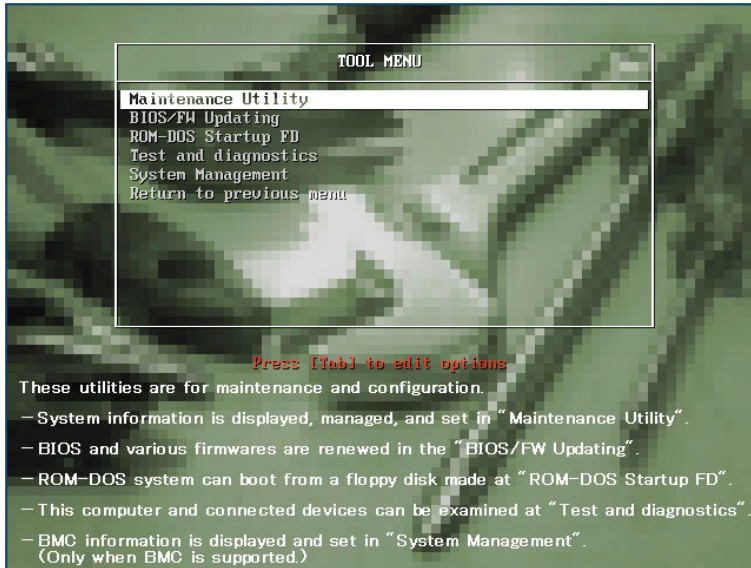

You can use the below functions for maintenance.

– Maintenance Utility

The Maintenance Utility is usually used by the service representative. (See Chapter 8.)

– BIOS/FW Updating

You can update the system BIOS by using the floppy disk (prepare a 3.5-inch floppy disk).

– ROM-DOS Startup FD

The ROM-DOS Startup FD is used for starting the ROM-DOS system.

– Test and diagnostics

This function allows you to diagnose this computer. (See Chapter 7.)

– System Management

You can configure the parameters of BMC (Baseboard Management Controller).

This function is not supported in this server.

- Tool menu (Redirection Mode)

If you want to operate this computer via the BIOS redirection (the console-less function), select this item.

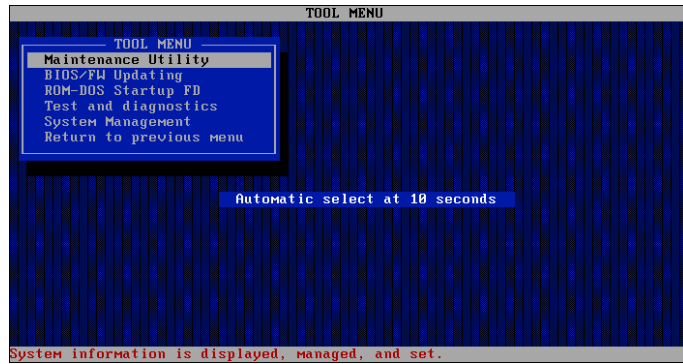

The menu's functions are the same as the "Tool menu (Normal Mode)".

---

## Autorun Menu

When the EXPRESSBUILDER disk is inserted into the optical disk drive, Windows automatically launches the menu as shown below.

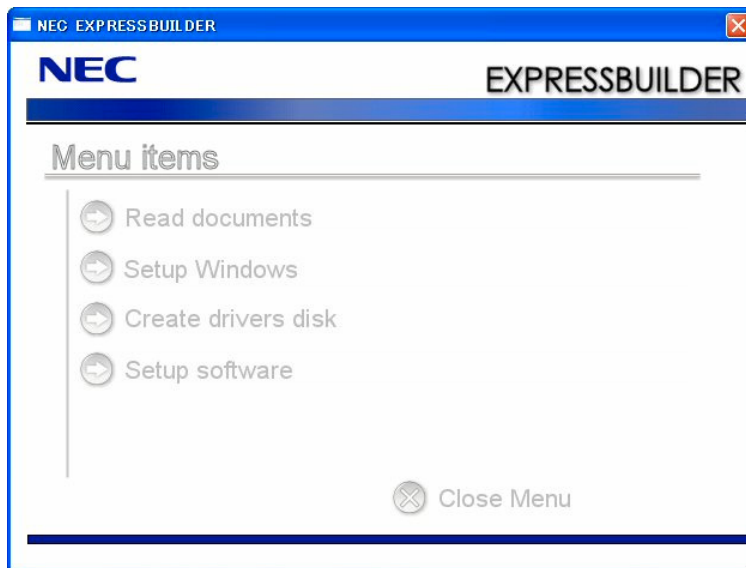

This menu is used to,

- Read the User's Guide or the other documents,
- Update the server system (Windows drivers), and
- Install the management software.

---

### NOTES:

- This menu requires Microsoft Windows XP, Vista or Windows Server 2003 (or later).
  - Some documents are provided in PDF format. Use the Adobe Reader to view or print these documents.
- 

If the menu does not appear, select "My computer" by using the Explorer, and double-click the icon of the optical disk drive that contains the EXPRESSBUILDER DVD.

Some menu items are grayed-out when the logon user does not have the authority of the administrator or the menu item is not available for your system.

To use the menu,

- Click on the menu items, or
- Click the right mouse button on the menu window.

## PARAMETER FILE CREATOR

"Parameter File Creator" is a tool to create [Parameter file] that is used for configuring the server with the Express Setup (see Chapter 5 for details).

If you use the Parameter file created by the Express Setup and Parameter File Creator to operate the setup, you can setup from the installation of OS to several utilities automatically except for a few key input to confirm the specification. Also, you can install the system with the same specification as before when re-installing the system. We recommend you to create [Parameter file] to setup the servers from NEC EXPRESSBUILDER.

When using a floppy disk, a USB floppy disk drive is required.

---

**IMPORTANT:** You can not create [Parameter file] for Microsoft Windows Server 2003 x64 Editions.

---

---

**NOTE:** You can install Windows Server 2003 without [Parameter file]. Also, you can modify/newly create [Parameter file] during the setup with NEC EXPRESSBUILDER.

---

## Parameter File

This section describes about specifying setup information that is necessary for OS installation and creating [Parameter file].

Follow the procedure below.

**IMPORTANT:** Do not remove NEC EXPRESSBUILDER DVD from drive during a parameter file creation.

1. Start the OS.
2. Insert the NEC EXPRESSBUILDER DVD into the optical disk drive.  
The menu will appear.
3. Right-click on the screen or left-click [Setup Windows]. The menu will appear.

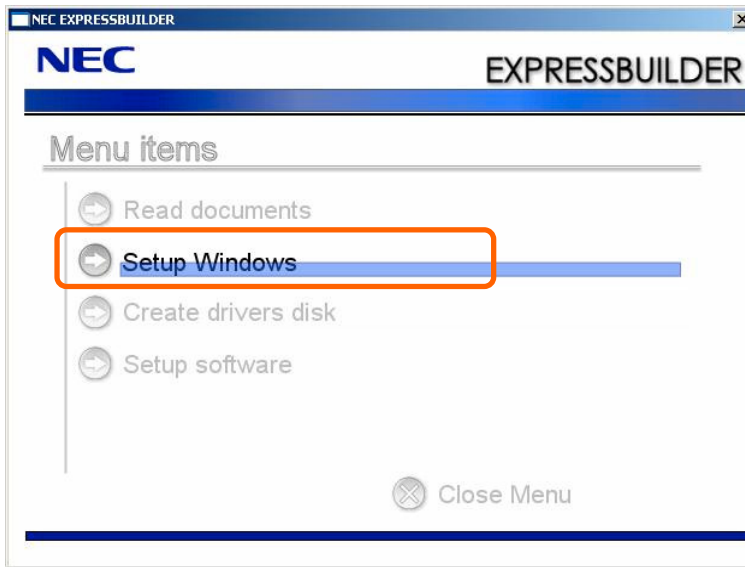

4. Click [Parameter File Creator].

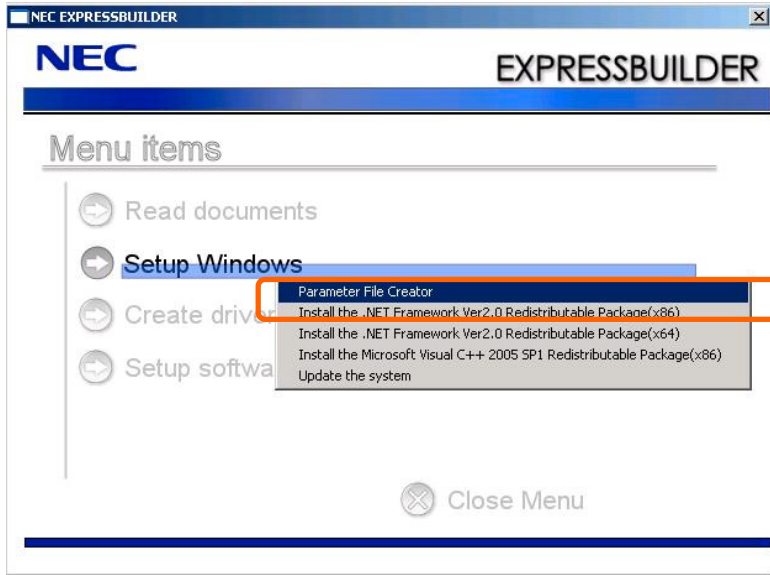

Parameter File Creator will appear.



5. [Load Parameters] step is displayed.

Select [Do not load parameters] from the menu, click [Next].

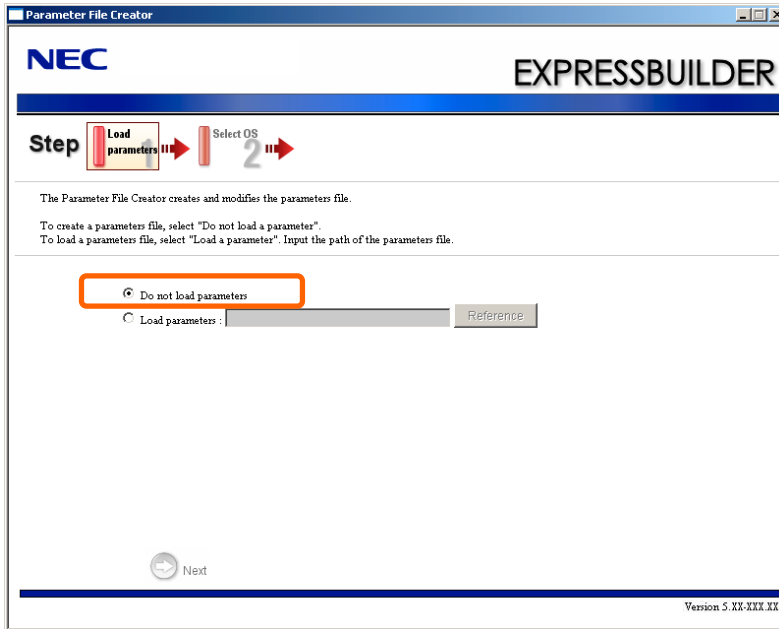

6. Select the installing Operating System.

Select [Install the Windows (32bit editions)] from the menu, click [Next].

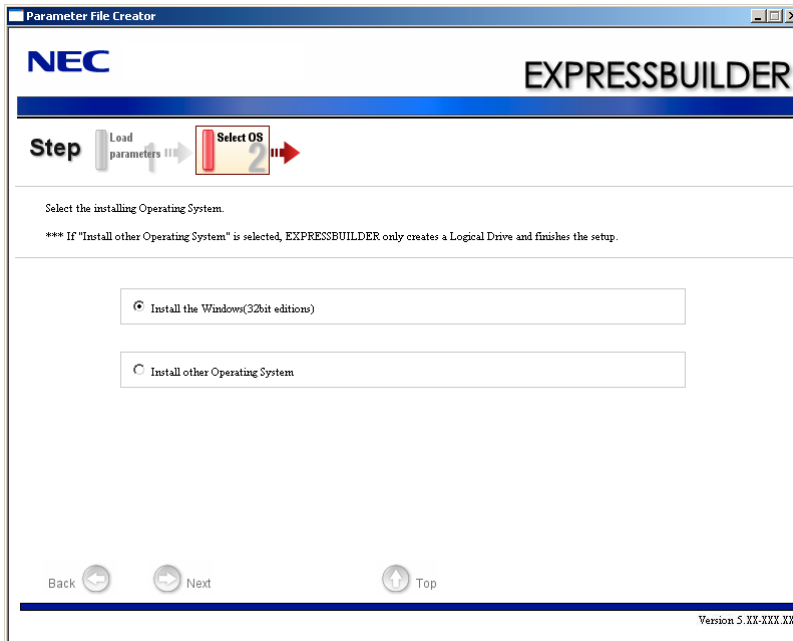

7. Enter the setting of a logical drive.

[Enter RAID setting] steps are displayed. Confirm the parameters, modify if necessary, and then click [Next].

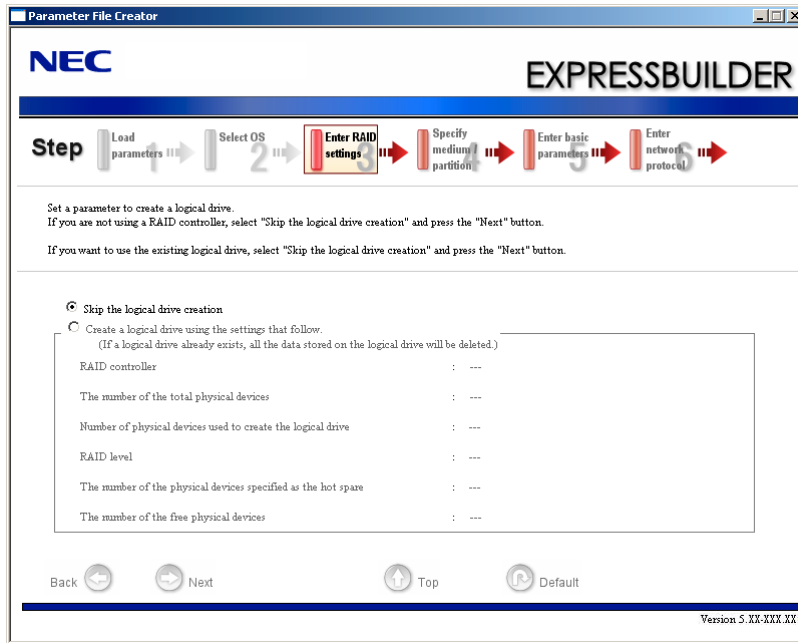

**IMPORTANT:** At "The number of the total physical devices", Parameter File Creator displays upper limit that the RAID controller can support.

The total of "The number of physical devices used to create the logical drive" and "The number of the physical devices specified as the hot spare" must not exceed "The number of the total physical devices" which connected to the target system.

**NOTE:** You can use only the physical devices that have same model number to configure logical drive.

8. Specify the installing medium and the Windows system partition.

[Specify medium / Partition] steps are displayed. Confirm the parameters, modify if necessary, and then click [Next].

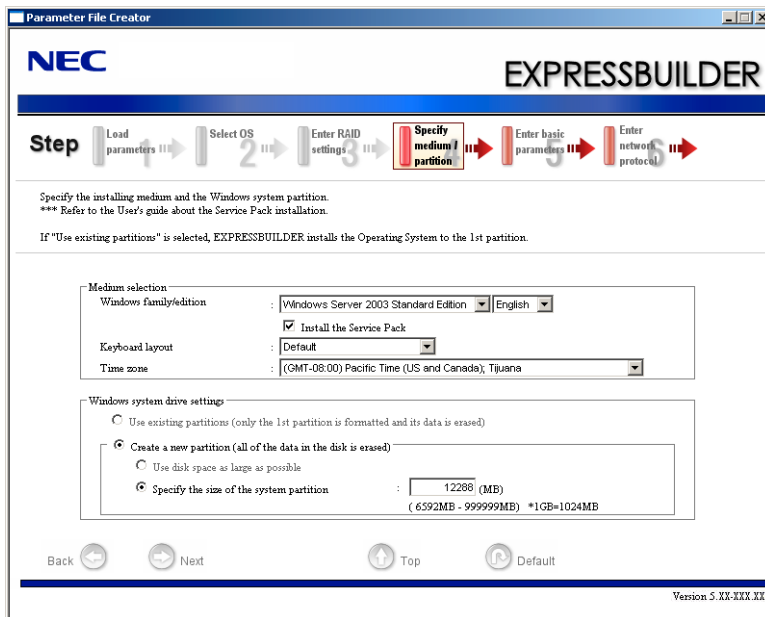

**IMPORTANT:**

- About partition size
  - Specify the partition size larger than required minimum size for OS installation.
  - Do not specify larger partition size than the capacity of connected hard disk drive.
  - You can not specify the partition size larger than 2,097,152MB (2TB) at RAID system.
- If you select "Create a new partition" at "Windows system drive settings", the contents of the hard disk will be all deleted.
- If "Use existing partitions" is selected, EXPRESSBUILDER installs the Operating System to the 1st partition (1st partition is deleted). The data in the other partition is kept if the system has two or more partitions. (See the figure below.)

First Partition Deleted	Second Partition Retained	Third Partition Retained
-------------------------------	---------------------------------	--------------------------------

- You can not re-install the system with the existing partition that is upgraded to Dynamic Disk remained. Do not select "Use existing partitions" at "Windows system drive settings".

9. Enter the user information and client license mode.

[Enter basic parameters] steps are displayed. Confirm the parameters, modify if necessary, and then click [Next].

---

**IMPORTANT:** Computer name and User name are required parameters.

---

**NOTE:** Even if you do not input value into "Administrator password", "Confirm password", "●●●●●●" is displayed.

---

10. Enter the setting of the network protocol.

[Enter network protocol] steps are displayed. Confirm the parameters, modify if necessary, and then click [Next].

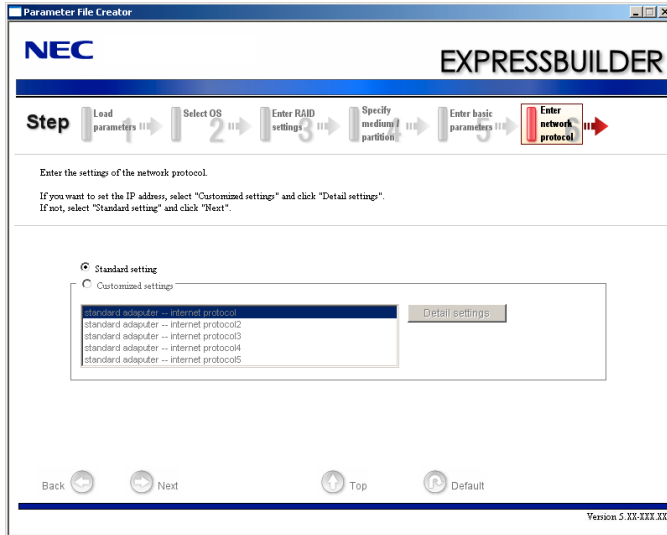

**NOTE:** The order of entry in custom setting may differ from the numbering of LAN port.

11. Enter the domain or workgroup name to be used.

[Enter domain account] steps are displayed. Confirm the parameters, modify if necessary, and then click [Next].

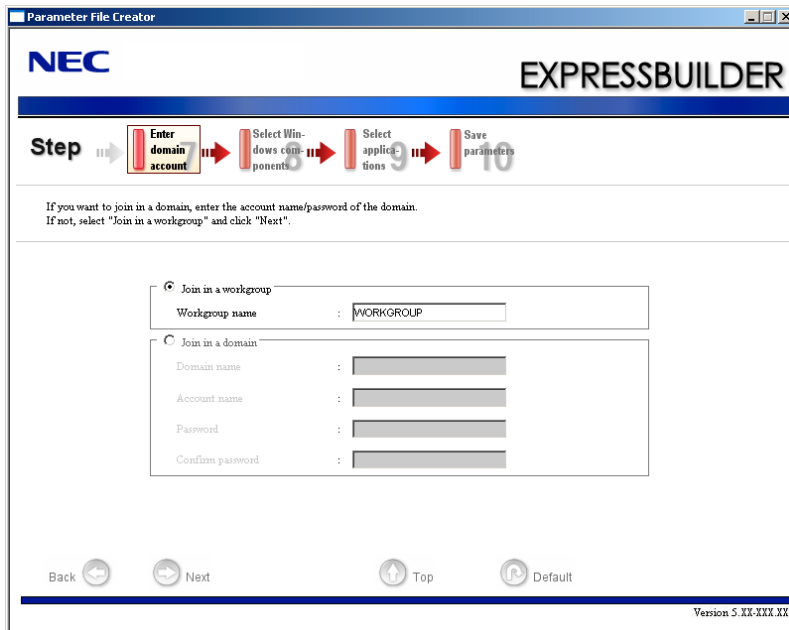

## 12. Select the installing components.

[Select Windows components] steps are displayed. Confirm the parameters, modify if necessary, and then click [Next]

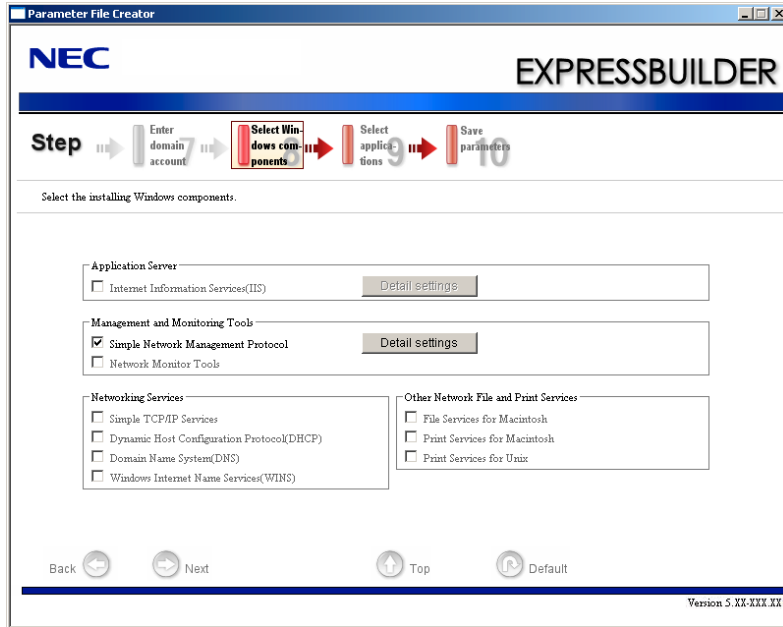

## 13. Select the installing applications.

[Select applications] steps are displayed. Confirm the parameters, modify if necessary, and then click [Next].

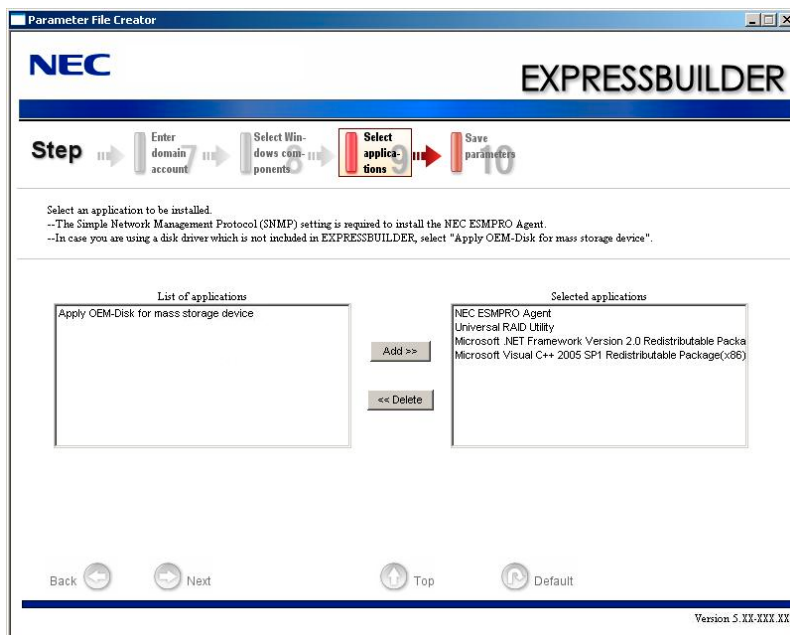

14. Save the parameters.

[Save parameters] steps are displayed.

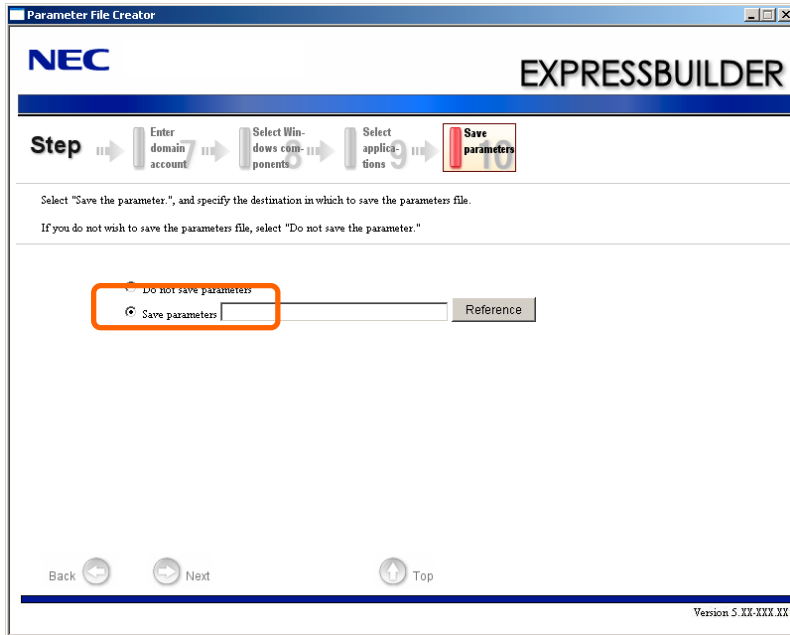

If you want to save the parameters, set the free formatted floppy disk.

Select [Save parameters], enter the file path of the parameters files into the text box and click [Next].

If not, select [Do not save parameters].

15. Saved to a floppy disk.

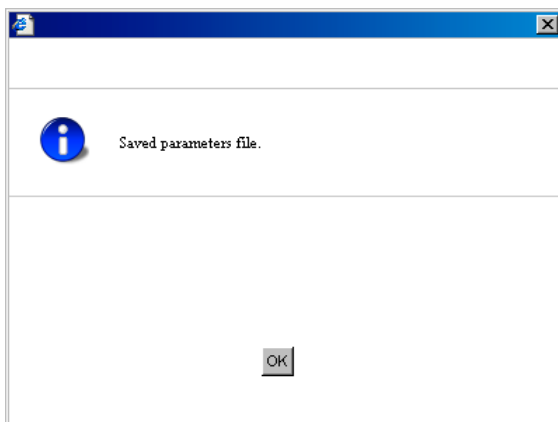

Now [the floppy disk containing the parameters file] has been created.

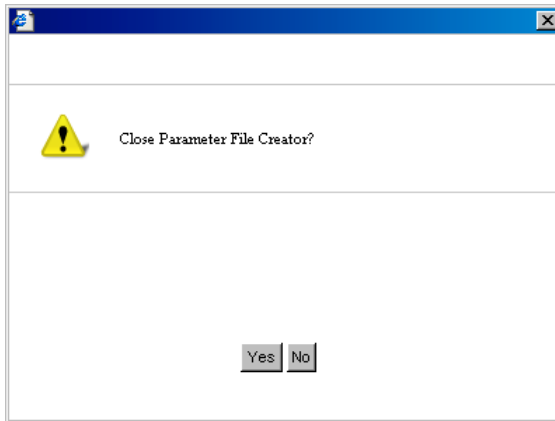

Click [Yes] to exit Parameter File Creator.

---

**NOTES:**

- If you modify existing information file (parameter file), click "Load Parameters" at [Load Parameters] screen. Refer to help to modify information file.
  - If you cancel operation on the way, click  at the upper-right corner of the screen.
-

## NEC ESMPRO

The NEC ESMPRO lets a system administrator manage remote servers across a network. NEC ESMPRO monitors server hardware and software configurations, failures, and performance. With log data collected by NEC ESMPRO, a system administrator can track long-term and short-term performance, monitor server usage, create graphs to record trends, and check server failure rates. The administrator can use the information collected to create more efficient data routing procedures and optimize server usage.

---

### Functions and Features

The NEC ESMPRO offers many functions and features for managing remote servers across a network. These features help the system administrator perform daily system operation, system extension, and transfer tasks. Some features of NEC ESMPRO Manager include:

- Hardware and software server configuration
  - Hardware resources mounted in servers, such as the CPU, memory, disks, RAID System, and LAN boards.
  - Software resources, such as operating system information and drivers running on each server.
- Server failures
  - On-screen real-time displays provide the system administrator with the failure type, location, cause, and suggested corrective action.
  - Failure data includes hardware failure information such as system board temperature, memory failure, crashes, and software failure information.
- Performance
  - NEC ESMPRO monitors server performance and displays server usage on the screen and displays information, such as the rate of CPU load, memory usage, disk usage, and LAN traffic. Usage threshold values can help the system administrator monitor and prevent server overloads.

**For installation procedure and detailed explanations on NEC ESMPRO, refer to the online document in the NEC EXPRESSBUILDER DVD.**

## Universal RAID Utility

Universal RAID Utility is an application to manage or monitor the following RAID Controllers.

- LSI Embedded MegaRAID
- N8103-116 RAID controller (128 MB, RAID0/1)
- N8103-117 RAID controller (128 MB, RAID0/1/5/6)

Before attempting to operate Universal RAID Utility, read the "Universal RAID Utility User's Guide" contained in NEC EXPRESSBUILDER DVD. The manual explains the installation procedure and notes on operating Universal RAID Utility.

---

### Setup with Express Setup

You can install Universal RAID Utility with Express Setup contained in NEC EXPRESSBUILDER DVD. When you start the Express Setup, a dialog to specify an application appears. Select [Universal RAID Utility] on the dialog.

---

### Manual Setup

#### Windows

You can start the setup program of Universal RAID Utility from [Autorun Menu].

Click [Setup Software] → [Universal RAID Utility] in [Autorun Menu].

You need to install the following software.

- Microsoft .NET Framework 2.0
- The Runtime component of the Microsoft Visual C++ 2005 SP1

You can install these software from [Autorun Menu] too.

Click [Setup Windows] → [Install the .NET Framework Ver 2.0 Redistributable Package (x86)] (If CPU architecture is x64, [Install the .NET Framework Ver2.0 Redistributable Package (x64)]) in [Autorun Menu] for the setup of Microsoft.NET Framework 2.0.

Click [Setup Windows] → [Install the Microsoft Visual C++ 2005 SP1 Redistributable Package(x86)] (Use the x86 package whatever the CPU architecture may be.) for the setup of the Runtime component of the Microsoft Visual C++ 2005 SP1.

---

## **Using Universal RAID Utility via Network**

Universal RAID Utility doesn't have the function of management to computer installed RAID Controller via network. If you want to manage it via network, please use the function of remote console (ex. Remote Desktop of Windows).

---

## **Easy Configuration**

You can not use the function of Easy Configuration to LSI Embedded MegaRAID.

---

## **Creating Logical Drive of RAID 6**

You must use four or larger Physical Devices for creating the Logical Drive of RAID 6 by Universal RAID Utility. If you want to create the Logical Drive from three Physical Devices, you need to use WebBIOS.

# Chapter 7

---

## Maintenance

This chapter describes the daily maintenance of the server and precautions when relocating or storing the server.

### MAKING BACKUP COPIES







NEC recommends you make backup copies of your valuable data stored in hard disk drives of the server on a regular basis. For backup storage devices suitable for the server and backup tools, consult with your service representative.



When you have changed the hardware configuration or BIOS configuration, select "System Information Management" and then "Save" of the Off-line Maintenance Utility to make a backup copy of the system information.

Also make a backup copy of the RAID configuration data if your system is in the RAID configuration. When your hard disk drives have been auto-rebuilt due to a failure, it is recommended to make a backup copy of the configuration data. To make a backup copy of the configuration data, use the configuration utility that is resident in the FLASH memory on the optional RAID controller board. Refer to the manual supplied with the board.

## CLEANING

Clean the server on a regular basis to keep the server in a good shape.

 <b>WARNING</b>	
     	<p>Observe the following instructions to use the server safely. Failure to follow these instructions may result in death or serious personal injury. See pages 1-3 to 1-8 for details.</p> <ul style="list-style-type: none"><li>■ Do not disassemble, repair, or alter the server.</li><li>■ Do not remove the lithium battery.</li><li>■ Disconnect the power plug before working with the server.</li></ul>

 <b>CAUTION</b>	
 	<p>Observe the following instructions to use the server safely. Failure to follow these instructions may cause a fire, personal injury, or property damage. See pages 1-3 to 1-8 for details.</p> <ul style="list-style-type: none"><li>■ Avoid installation in extreme temperature conditions.</li><li>■ Make sure to complete board installation.</li><li>■ Protect the unused connectors with the protective cap.</li></ul>

---

## Cleaning the Server

For daily cleaning, wipe the external surfaces of the server with a dry soft cloth. Follow the procedure below if stains remain on the surfaces:

---

**IMPORTANT:**

- To avoid altering the material and color of the server, do not use volatile solvents such as thinner and benzene to clean the server.
  - The power receptacle, the cables, the connectors on the rear panel of server, and the inside of the server must be kept dry. Do not moisten them with water.
- 

1. Make sure that the server is off-powered (the POWER/SLEEP lamp goes off).
2. Unplug the power cord of the server from a power outlet.
3. Wipe off dust from the power cord plug with a dry cloth.
4. Soak a soft cloth in neutral detergent that is diluted with cold or lukewarm water, and squeeze it firmly.
5. Rub off stains on the server with the cloth prepared in Step 4.
6. Soak a soft cloth in water, squeeze it firmly, wipe the server with it once again.
7. Wipe the server with a dry cloth.
8. Wipe off dust from the fan exhaust opening on the rear of the server with a dry cloth.

---

## Cleaning the Interior



One of the most important items in a good maintenance program is regular and thorough cleaning of the interior of the server, especially around the mother board.

Dust buildup inside the server can lead to several problems. As dust acts as a thermal insulator, a buildup can prevent proper system cooling. Excessive heat will shorten the life of server components. Also, dust may contain conductive or corrosive materials that can cause short circuits or corrosion of electrical contacts.

How often you should clean the interior of the server depends on the environment in which it is located. For most office environments, you probably should clean the server every 12 months. For more severe environments, clean the interior every 6 months.

Cleaning the interior of the server entails powering off the server and removing the left side cover. You will need a small vacuum cleaner (with plastic tipped nozzle and electrostatic protection), computer grade canned air, and a small brush for cleaning the interior.

Follow the procedure below to clean the interior of the server.

 <b>WARNING</b>	
	<p>Unplug all power cords.</p> <p>Unplug all power cords before performing any maintenance. Voltage is present inside the server and display unit even after the power is turned off. All voltage is removed only when the power cord is unplugged.</p>

---

**IMPORTANT:** Do not use the brush made of chemical fabric, or the cleaning material that will generate an electrostatics.

---

1. Turn off the server and unplug all power cables.
2. Remove the left side cover. (See Chapter 9.)
3. Remove the dust accumulate on the air inlet of the front and the rear fan.
4. Use a small brush to loosen any dust and debris on the mother board.
5. Use computer grade canned air to blow dust off components on the mother board.
6. Use a small vacuum cleaner with plastic tip to vacuum out dust and debris from the interior of the server.
7. Reinstall the left side cover. (See Chapter 9.)
8. Reconnect all power cables and turn on the server.

---

## Cleaning the Keyboard/Mouse

Make sure that the server and peripheral devices are all off-powered (the POWER/SLEEP lamp goes off), and then wipe the keyboard surface with a dry cloth.

The mouse operation depends on the degree of smoothness of the internal ball rotation. To keep the mouse ball clean, use the mouse in a place with little dust. Follow the steps below to clean the mouse regularly:

1. Prepare cold or lukewarm water, neutral detergent, alcohol, two dry soft clothes, and cotton swabs.
2. Make sure that the server is off-powered (the POWER/SLEEP lamp goes off).
3. Turn the mouse upside down, and rotate the mouse ball cover counterclockwise to remove it.
4. Take out the ball from the mouse. Cover the bottom of the mouse with your hand, and turn your hand holding the mouse (the mouse is on your palm with the button upward). The mouse ball is released onto your palm.

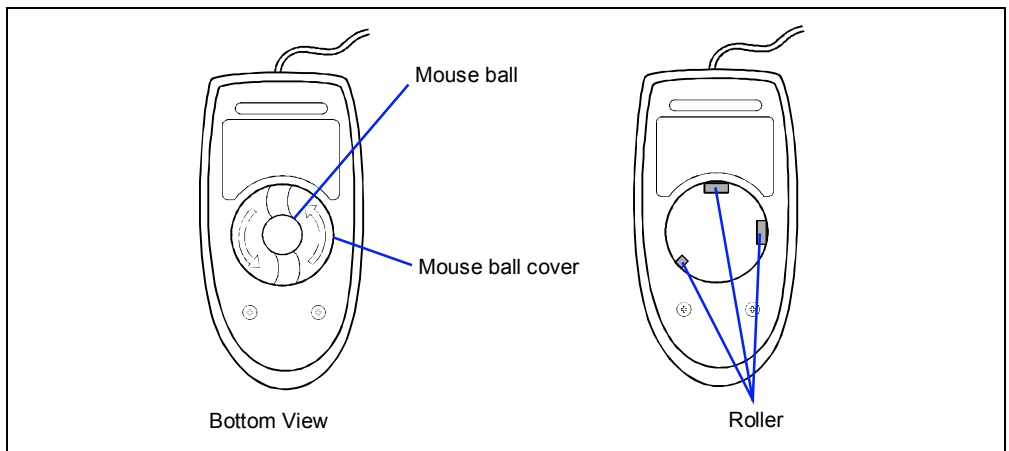

5. Soak a soft cloth in neutral detergent that is diluted with cold or lukewarm water, and squeeze it firmly.
6. Rub off stains on the mouse ball. Softly wipe the mouse ball with the cloth prepared in Step 5.
7. Wipe the mouse ball with a dry soft cloth.
8. Wipe three small rollers inside the mouse with a cotton swab soaked with alcohol. Wipe stains slowly and carefully by rotating rollers with the tip of the cotton swab.
9. Blow out any dust from the mouse. Protect your eyes from the dust.
10. Put the mouse ball back into the mouse.
11. Place the mouse ball cover, and rotate it clockwise until it is locked.

---

## Cleaning Disc

A dusty disc or dust-accumulated tray causes the device to fail to read data correctly.

Follow the procedure below to clean the tray and disc regularly:

1. Make sure that the server is powered (the POWER/SLEEP LED is lit).
2. Press the CD tray Open/Close button on the front of the optical disk drive. The tray opens.
3. Hold the disc lightly and take it out from the tray.

---

**NOTE:** Do not touch the signal side of the disc with your hand.

---

4. Wipe the tray with a dry soft cloth.

---

**IMPORTANT:** Do not wipe the lens of the optical disk drive. Doing so may damage the lens and may cause a malfunction of the drive.

---

5. Push on the tray front to close the tray.
6. Wipe the signal side of the disc with a dry soft cloth.

---

**IMPORTANT:** Wipe disc from the center to the outside. Use only disc cleaner if necessary. Cleaning a disc with record spray/cleaner, benzene, or thinner causes damage to the disc contents. At worst, inserting the disc into the server may cause failure.

---

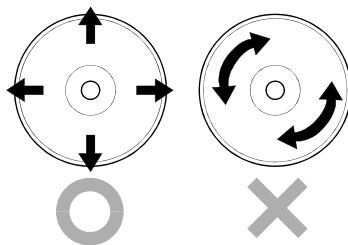

## SYSTEM DIAGNOSTICS

The System Diagnostics runs several tests on the server.

Select [Tool menu] - [Test and diagnostics] in the NEC EXPRESSBUILDER to diagnose the system.

---

### Test Items

The following items are tested in system diagnostics.

- Memory
- CPU cache memory
- Hard disk drive used as a system

---

**IMPORTANT:** When executing the system diagnostics, make sure to disconnect the LAN cable. Executing the system diagnostics with the LAN cable connected, the network may be influenced.

---

---

**NOTE:** On checking the hard disk drive, no data is written into the disk.

---

---

### Startup and Exit of System Diagnostics

There are two ways to diagnose the server: to use the local console (keyboard) of the server itself, and to use the management PC via serial port (remote console).

Procedures to start the diagnostics program are as follows:

1. Shutdown the OS, and power off the server. Then, unplug the power cord.
2. Disconnect all the LAN cables from the server.
3. Plug the power cord and power on the server.
4. Use the NEC EXPRESSBUILDER DVD to start the system.
5. Select [Tool menu (Normal mode)] when local console of the server is used for, or select [Tool menu (Redirection mode)] when remote console is used for.

---

**NOTE:** If the system displays the [Language selection] menu, select [English].

---

**6.** Select [Test and diagnostics].

Select [End-User Mode] and the system diagnostics starts. The diagnostics will be completed in approximately three minutes. When the diagnostics is completed, the screen of the display changes as shown below:

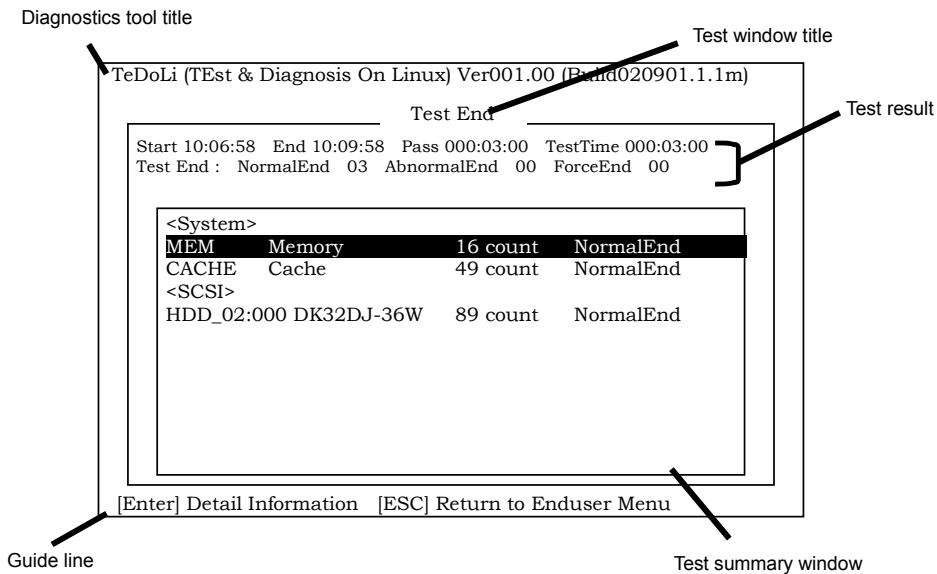

- Diagnostics tool title  
Shows the name and version of the diagnostic tool.
- Test window title  
Shows the progress of the diagnostics. "Test End" is displayed when the diagnostics completes.
- Test result  
Shows the start, end, and elapsed time and completion status of the diagnostics.
- Guide line  
Shows the details of the keys to operate window.
- Test summary window  
Shows the results of each test that executed the diagnostics. Move the cursor and press the **Enter** key on the cursor line to display the details of the test.

When an error is detected by the system diagnostics, the relevant test result in the test Summary window is highlighted in red, and "Abnormal End" is displayed in the result on the right side.

Move the cursor to the test that detected the error, and press the **Enter** key. Record the error message that has been output to the Detail Information screen and contact your service representative.

7. Follow the guide line shown at the bottom of the screen, and press the **Esc** key.  
The [Enduser Menu] below is displayed.

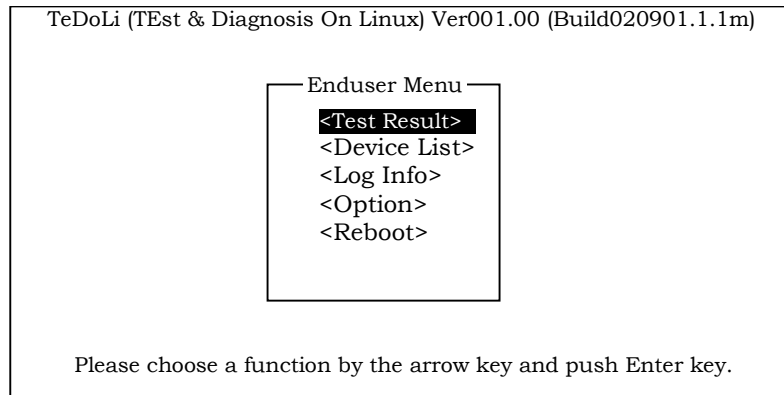

- <Test Result> Shows the diagnostics completion screen of the above diagnostics.
  - <Device List> Shows a list of connected devices.
  - <Log Info> Shows the log information of the diagnostics. It can be saved on a floppy disk.  
To save it on a floppy disk, insert a formatted floppy disk to the floppy disk drive, and select <Save(F)>.
  - <Option> Optional features can be used from this menu.
  - <Reboot> Reboots the system.
8. Select <Reboot> in the [Enduser Menu] above.  
The server restarts and the system is started from the NEC EXPRESSBUILDER.
  9. Exit the NEC EXPRESSBUILDER, and remove the DVD-ROM from the optical disk drive.
  10. Power off the server and unplug the power cord from the receptacle.
  11. Reconnect all the LAN cables that have been disconnected in Step 2 to the server.
  12. Plug in the power cord.

This completes the system diagnostics.

## RELOCATING/STORING THE SERVER

Follow the procedure below to relocate or store the server:

<b>⚠ CAUTION</b>	
	<p>Observe the following instructions to use the server safely. Failure to follow these instructions may cause a fire, personal injury, or property damage. See pages 1-3 to 1-8 for details.</p> <ul style="list-style-type: none"><li>■ Never attempt to lift the server only by yourself.</li><li>■ Do not install the server in any place other than specified.</li><li>■ Do not connect/disconnect any interface cable with the power cord of the server plugged to a power source.</li></ul>

---

### IMPORTANT:

- If the server needs to be relocated/stored due to a change in the floor layout to a great extent, contact the service representative.
  - Make sure to make a backup copy of your valuable data in the hard disk drive, if any.
  - Make sure not to apply a shock to hard disk drives to relocated the server if the contains any.
- 

1. Take a media out of the server, if any.
2. Power off the server (the POWER/SLEEP lamp goes off).
3. Unplug the power cord of the server from a power outlet.
4. Remove all the cables from the server.
5. Hold the server by its bottom to carry the server.

---

**IMPORTANT:** Do not hold the front mask to lift the server. The front mask may be disengaged from the server, causing personal injury.

---

6. Protect the server with the shock-absorbing materials, and pack it securely.

# Chapter 8

---

## Troubleshooting

If your server does not operate as expected, read this chapter before assuming a failure.

---

**NOTE:** For provision against an unexpected failure, it is recommended to install NEC ESMPRO to your computer.

---



## LAMPS

The following describes lamps on the server and their indications. See Chapter 2 for each location.

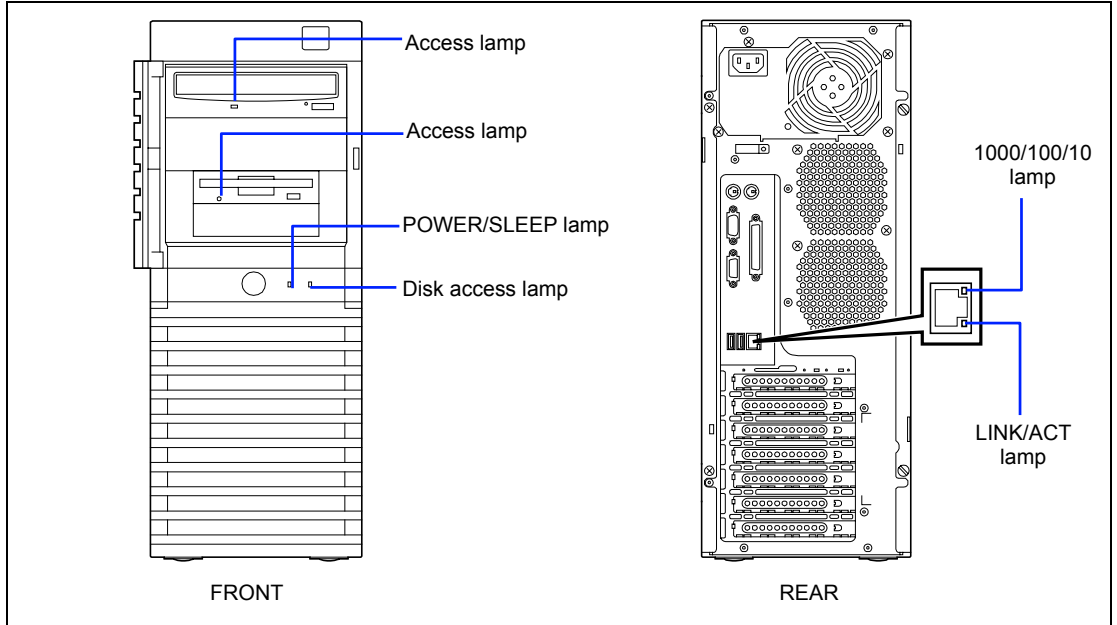

---

## **POWER/SLEEP Lamp**

The green POWER/SLEEP lamp lights to indicate normal operation while the server is powered. When the server is off-powered, the POWER/SLEEP lamp stays unlit.

The POWER/SLEEP lamp indicates that the server is running in the power-saving mode (sleep mode). If the OS supports the power-saving mode such as Windows, pressing the POWER/SLEEP switch blinks the POWER/SLEEP lamp in green and places the server in the power-saving mode. Press the POWER/SLEEP switch to turn out the POWER/SLEEP lamp and place the server back in the normal mode.

The power-saving mode is only available when the OS supports the power-saving feature. Some OS's allow you to set the server to automatically turn in the power-saving mode when no access is made to the server for a certain period of time or to select the power-saving mode with a command.

---

## **DISK ACCESS Lamp**

The DISK access lamp lights in green every time any of internal hard disk drive is accessed. The access lamp for the optical disk drive lights when access is made to a media in the drive.

---

## **LINK/ACT Lamp**

The link/ACT lamp indicates the state of each network port normally equipped with the server. If the power is supplied to the server and the hub and they are correctly connected with each other, the lamp is lit green (LINK state). If information is transmitted through a network port, the lamp blinks green (ACT state).

If the lamp is not lit in the LINK state, check the network cable and the cable connection. If the lamp is not lit still after the checking, the network (LAN) controller may be defected. Contact your service representative.

---

## **1000/100/10 Lamp**

The 1000/100/10 lamp indicates whether each of the network ports normally equipped with the server is operated through the 1000BASE-T, 100BASE-TX or 10BASE-T network interface. If the lamp is lit orange, the network port is operated through 1000BASE-T. If the lamp is lit green, the network port is operated through 100BASE-TX. If the lamp is off, the network port is operated through 10BASE-T.

## ERROR MESSAGES

If an error occurs in the server, an error message appears on the display unit connected to the server.

---

### Error Messages after Power-on

Powering on the server automatically starts the self-diagnostic program, POST (Power On Self-Test). When the POST detects any error, it displays an error message and its measure on the display unit.

Follow the table below to troubleshoot such errors. However, even when there is no hardware failure, use of the keyboard or mouse at the following timing causes the POST to assume a keyboard controller error and stop processing.

- Immediately after the server is powered
- Immediately after the system is rebooted in response to a keyboard instruction (simultaneous key entry of **Ctrl + Alt + Delete**)
- Immediately after the system is rebooted in response to an OS instruction
- During hardware initialization following restart of the POST

When the POST detects a hardware failure due to the above reason, restart the server once again. If the same error message reappears, you may assume there is no hardware error. To ensure normal operation of the server, however, make sure to follow the following restrictions.

- Do not make any keyboard entry or use the mouse before the memory count appears on the screen following the server power-on.
- Do not make any keyboard entry or use the mouse before the start-up message of the Configuration Utility appears on the screen following the server reboot.

---

**IMPORTANT:** Take a note on the on-screen message before contacting your service representative. The alarm indication would be a great help for maintenance.

---

## POST Error Messages

When POST detects an error, it displays an error message on the display unit screen. The following table lists error codes, error messages, and actions to take.

**IMPORTANT:** Take a note on the messages displayed before consulting with your service representative. Alarm messages are useful information for maintenance.

Error code	Error message	Recommended Action
0200	Failure Fixed Disk	Contact your service representative.
0210	Stuck Key	Disconnect the keyboard and connect it again.
0213	Keyboard locked - Unlock key switch	Release the lock of the key switch. If the error cannot be corrected in spite of the release of the lock, contact your service representative.
0220	Monitor type does not match CMOS - Run SETUP	Start the SETUP. If the error cannot be corrected in spite of the start of SETUP, contact your service representative.
0230	System RAM Failed at offset:	Contact your service representative.
0231	Shadow Ram Failed at offset:	
0232	Extended RAM Failed at address line:	
0250	System battery is dead - Replace and run SETUP	Contact your service representative to replace the battery. (After restarting the computer, start the SETUP to provide the setting again.)
0251	System CMOS checksum bad - Default configuration used	The default values have just been set. Start the SETUP to provide the setting again. If the error cannot be corrected, contact your service representative.
0252	Password checksum bad - Passwords cleared.	The password has just been cleared. Start the SETUP to provide the setting again.
0260	System timer error	Start the SETUP to set the date and time again. If the same error occurs successively in spite of the resetting, contact your service representative.
0270	Real time clock error	
0271	Check date and time settings.	
02B0	Diskette drive A error	Start the SETUP to set the "Legacy Floppy A" in the Main menu again. If the same error occurs successively in spite of the resetting, contact your service representative.
02B2	Incorrect Drive A type - run SETUP	Start the SETUP to provide the setting again. If the error cannot be corrected, contact your service representative.
02D0	System cache error - Cache disabled	The cache cannot be used. Contact your service representative.

<b>Error code</b>	<b>Error message</b>	<b>Recommended Action</b>
02D1	System Memory exceeds the CPU's caching limit.	Contact your service representative.
02F4	EISA CMOS not write able	
02F5	DMA Test Failed	
02F6	Software NMI Failed	
02F7	Fail-safe Timer NMI Failed	
0615	COM B Configuration changed	Start the SETUP and select [Advanced] - [Peripheral Configuration] - [Serial Port A] and [Serial Port B] to check if settings are correct. If the error cannot be corrected, contact your service representative.
0B5F	Forced to use Processor with error	Contact your service representative.
0B71	System Temperature out of the range	Check internal fans for dust or debris. Contact your service representative for maintenance.
0BB2	POST memory Resize	Contact your service representative.
8151	Password Cleared By Jumper	Restore the jumper setting after powering off the server.
None	Expansion ROM not initialized – PCI Mass Storage Controller in slot xx (xx: slot number)	Disable initialization of the optional device expansion ROM by using the BIOS SETUP utility (see Chapter 4).
	All Memories are No Good. Please replace Memories and clear Memory ECC Error Information by SETUP.	Contact your service representative.

## Beep Codes

If an error occurs during the POST, the server beeps, indicating the type of error.

Each number indicates the number of short beeps, and a hyphen indicates a pause. For example, the beep interval 1-3-1-1 indicates 1 beep, pause, 3 beeps, pause, 1 beep, pause, and 1 beep notifying that the DRAM refresh test error occurred.

Beep code	Description	Recommended action
3-3 (repetitive)	ROM checksum error	Contact your service representative to replace the mother board.
1-2-2-3		
1-3-1-1	DRAM refresh test error	Check if the DIMMs are properly connected. If the error persists, contact your service representative to replace DIMM or mother board.
1-3-1-3	Keyboard controller error	Disconnect the keyboard and connect it again. If the error persists, contact your service representative to replace the mother board.
1-3-3-1	No memory or capacity check error	Check if the DIMMs are properly connected. If the error persists, contact your service representative to replace DIMM or mother board.
1-3-4-1	DRAM address error	
1-3-4-3	DRAM test Low Byte error	
1-4-1-1	DRAM test High Byte error	
1-5-1-1	CPU startup error	Contact your service representative to replace the mother board.
1-5-2-2	No CPU installed	Contact your service representative to replace the CPU or mother board.
2-1-2-3	BIOS ROM copyright test error	Contact your service representative to replace the mother board.
2-2-3-1	Unexpected interrupt test error	
1-2	Option ROM initialization error	Check if BIOS SETUP is correctly configured. If an expansion of Option ROM for additionally installed PCI board is not displayed, check if the PCI board is properly installed. If the error persists, contact your service representative to replace the mother board or PCI board.

## SOLVING PROBLEMS

When the server fails to operate as expected, see the following to find out your problem and follow the instruction given before asking for repair.

If the server still fails to operate successfully after solving your problem, take a note on the on-screen message and contact your service representative.

---

### Problems with NEC Express Server

#### No screen display appears and beep occurs.

- Is the DIMM board installed securely?
  - Check whether the DIMM board is inserted into the mating connector securely.
  - Make sure the jumper switches have been returned to their original positions after CMOS clearing. See "Configuring Mother Board Jumpers" in Chapter 4 for the positions of the jumper switches.

#### Fail to power on the server:

- Is the server is properly supplied with power?
  - Check if the power cord is connected to a power outlet (or UPS) that meets the power specifications for the server.
  - Check the power cord for broken shield or bent plugs.
  - Make sure the power breaker for the connected power outlet is on.
  - If the power cord is plugged to a UPS, make sure the UPS is powered and it outputs power. See the manual that comes with the UPS for details.

Power supply to the server may be linked with the connected UPS using the BIOS Setup utility of the server.

<Menu to check: [Advanced] - [AC-LINK]>
- Did you press the POWER/SLEEP switch?
  - Press the POWER/SLEEP switch on the front of the server to turn on the power (the POWER/SLEEP lamp lights).

**POST fails to complete:**

- Is the DIMM board installed?
  - Check the installation location of DIMMs (see Chapter 9).
- Is the memory size large?
  - The memory check may take a few seconds if the memory size is large. Wait for a while.
- Did you perform any keyboard or mouse operation immediately after you started the server?
  - If you perform any keyboard or mouse operation immediately after start-up, POST may accidentally detect a keyboard controller error and stops proceeding. In such a case, restart the server once again. Do not perform any keyboard or mouse operation until the BIOS start-up message appears when you restart the server.
- Does the server have contains appropriate memory boards or PCI devices?
  - Operation of the server with unauthorized devices is not guaranteed.

**Fail to access to internal or external devices (or such devices fail to operate):**

- Are cables properly connected?
  - Make sure that the interface cables and power cord are properly connected. Also make sure that the cables are connected in the correct order.
- Is the power-on order correct?
  - When the server has any external devices connected, power on the external devices first, then the server.
- Did you install drivers for connected optional devices?
  - Some optional devices require specific device drivers. Refer to the manual that comes with the device to install its driver.
- Is BIOS configuration correct?
  - Some devices connected to the serial or parallel port may require I/O port address or operation mode settings. Refer to the manual that comes with the board for details to make correct settings.

**The keyboard or mouse fails to operate:**

- Is the cable properly connected?
  - Make sure that the cable is connected to the correct connector on the rear of the server.
  - The keyboard or mouse does not operate if it is connected when the server is powered (not applicable to USB devices). Power of the server first and connect it properly.
- Are the server drivers installed?
  - Refer to the manual that comes with your OS to check that the keyboard and mouse drivers are installed. (These drivers are installed along with the OS.) Some OS's allow you to change the keyboard and mouse settings. Refer to manual that comes with your OS to check that the keyboard and mouse settings are correct.

**Fail to access (read or write) to the floppy disk:**

- Does the floppy disk drive contain a floppy disk?
  - Insert a floppy disk into the floppy disk drive until it clicks.
- Is the floppy disk write-protected?
  - Place the write-protect switch on the floppy disk to the "Write-enabled" position.
- Is the floppy disk formatted?
  - Use a formatted floppy disk or format the floppy disk in the floppy disk drive. Refer to the manual that comes with the OS for formatting a floppy disk.
- Is BIOS configuration correct?
  - The internal floppy disk drive may be disabled with the BIOS SETUP utility of the server. Check the setting with the BIOS SETUP utility.  
 <Menus to check:-[Main] - [Legacy Diskette A]>

**Fail to access to the DVD/CD-ROM:**

- Is the DVD/CD-ROM properly set in the optical disk drive tray?
  - The tray is provided with a holder to secure the DVD/CD-ROM. Make sure that the DVD/CD-ROM is placed properly in the holder.
- Is the DVD/CD-ROM applicable to the server?
  - The DVD/CD-ROM for Macintosh is not available for use.
  - For the disk which does not conform to the CD standard, the playback of such a disk with the optical disk drive is not guaranteed.

**The POWER/SLEEP lamp goes on when the power cord is connected:**

- When the server receives an AC power after the power cord is connected, the POWER/SLEEP lamp goes on. This is a normal operation of the server, not a fault. The lamp will go off when DC power is turned on, and then off.

**Inserted the correct DVD/CD-ROM but the message like the following is displayed:**

The DVD/CD-ROM is not inserted or the wrong DVD/CD-ROM is inserted. Please insert the correct DVD/CD-ROM. OK
--

- Is the data side of the DVD/CD-ROM dirty or injured?
  - Take the DVD/CD-ROM out of the optical disk drive, confirm that it is not dirty or injured, reset and click [OK].

**Fail to access the hard disk drive:**

(Refer to the documentation supplied with the RAID Controller.)

- Is the hard disk drive applicable to the server?
  - Operation of any device that is not authorized by NEC is not guaranteed.
- Is the hard disk drive properly installed?
  - See Chapter 9.

**Fail to access the (internal or external) SCSI devices:**

- Is the SCSI device applicable to the server?
  - Operation of any SCSI device that is not authorized by NEC is not guaranteed.
- Is the cable connection changed?
  - See Chapter 10 for cable connection.
- Are SCSI devices properly configured?
  - When the server has external SCSI devices connected, hard disk drive settings, including SCSI ID and terminator, are required. Refer to the manual that comes with the SCSI device for details.
- Is cable length exceeded?
  - Refer to the manual that comes with the SCSI device for details.
- Are the optional SCSI controllers properly configured?
  - Use the BIOS Setup utility for proper configuration of SCSI devices connected to the SCSI connector on the mother board. When the server has an optional SCSI controller installed and SCSI devices connected to it, use the BIOS Setup utility that comes with the optional SCSI controller for proper configuration. See the manual that comes with the optional SCSI controller for details.

**Event logs in using Intel Network adapter teaming**

Event Type: Warning  
 Event Source: IANSMiniport  
 Event Category: None  
 Event ID: 11  
 Description: Adapter link down: Intel(R)PRO/1000 ----

Event Type: Warning  
 Event Source: IANSMiniport  
 Event Category: None  
 Event ID: 13  
 Description: Intel(R)PRO/1000 ---- has been deactivated from the team.

Event Type: Error  
 Event Source: IANSMiniport  
 Event Category: None  
 Event ID: 16  
 Description: Team #0: The last adapter has lost link.  
 Team network connection has been lost.

Event Type: Warning  
 Event Source: IANSMiniport  
 Event Category: None  
 Event ID: 22  
 Description: Primary Adapter does not sense any Probes:  
 Intel(R)PRO/1000 ---- Possible reason: partitioned Team.

→ Above-mentioned event log will appear when the system starts.  
 There is no problem in LAN driver operation.

---

## Problems with Windows

**There are some cases that an event log is registered as follows when you install Windows Server 2003 x64 Editions.**

Source: DCOM  
Category: Error  
Event ID: 10016  
Description: The application-specific permission settings do not grant Local Activation permission for the COM server application with CLSID {555F3418-D99E-4E51-800A-6E89CFD8B1D7} to the user {NT AUTHORITY\LOCAL SERVICE} SID {S-1-5-19}.  
This security permission can be modified using the component Services administrative tool.

→ It is not a problem in operating the system.

**There are some cases that an event log is registered as follows when you install Windows Server 2003 x64 Editions.**

Event Source: Service Control Manager  
Event Type: Error  
Event ID: 7011  
Description: Timeout (30000 milliseconds) waiting for a transaction response from the IMAP4Svc service.

→ When this event is not registered by rebooting the system, it is not a problem in operating the system.

**There are some cases that an event log is registered as follows when you operate Windows Server 2003 R2.**

Source: IPMIDRV  
Type: Error  
Event ID: 1001  
Description: The IPMI device driver attempted to determine if the system supported an IPMI BMC device. The driver attempted to detect the presence of the IPMI BMC by searching the SMBIOS for Type 38 record. But either no record was found or the record was not compatible with the version of the device driver. If a SMBIOS Type 38 record was detected, the Dump Data field of the event contains a binary representation of the record.

→ If you use "Hardware Management" which is provided by Windows Server 2003 R2, above-shown event log will be registered.

For more details, refer to "Enabling Microsoft Windows Server 2003 R2 Hardware Management" on the following site.

[NEC Express5800 Web Site]

[http://www.nec.co.jp/express/download/W2K3\\_R2](http://www.nec.co.jp/express/download/W2K3_R2)

**The system displays the message below and fails to log on.**

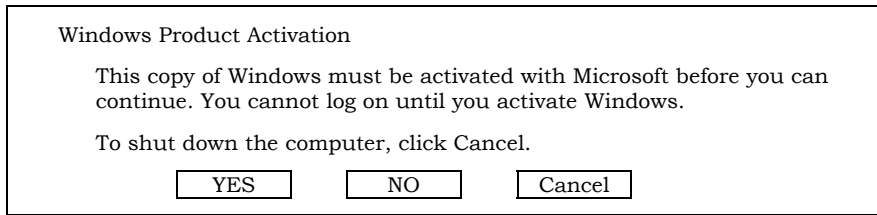

→ In Windows Server 2003, the above message will be displayed if you use the operating system without executing the license authentication. Select "Yes", and execute the procedure for license authentication.

**Cannot install the operating system correctly.**

- Did you confirm the notes on installing the operating system?

→ See Chapter 6.

**During installation, the following warning is registered in the System Log of the EventViewer:**

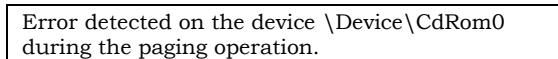

→ There is no problem on this issue.

**Fail to start the OS:**

- Is the NEC EXPRESSBUILDER DVD in the optical disk drive?

→ Take out the NEC EXPRESSBUILDER DVD and restart the server.

- Is the OS broken?

→ Use recovery process to recover the system.

**The OS presents unstable operation:**

- Did you update the system?

→ Installing a network drive after installation of the OS may cause unstable operation. Use the NEC EXPRESSBUILDER DVD to update the system. (See Chapter 6.)

**The system does not restart automatically when a stop error occurs, though the system is adjusted to automatically restarting:**

→ When the system does not restart automatically, restart it manually.

**The system restarts automatically when a stop error occurs, though the system is NOT adjusted to automatically restarting:**

- There is no problem about this issue.  
Check the System Event Log to confirm that STOP error occurred.

**Cannot turn the power OFF at the blue screen:**

- If you want to turn off the power at the blue screen, execute forced shutdown (forced shutdown: continue to press POWER/SLEEP switch for 4 seconds). The power will not be turned off if you press the switch for less than 3 seconds.

**The PXE boot (network boot) fails or the server is not found on the network:**

- Is the cable connected properly?
  - Connect the proper cable to the network port on the rear of the Express server. In addition, make sure that the used cable conforms to the network interface standard.
- Is BIOS configuration correct?
  - The internal LAN controller may be disabled with the BIOS Setup utility of the server. Check the setting with the BIOS setup utility.
- Have the protocol and service already configured?
  - Install the distinctive network driver for the server. Make sure that the protocol, such as TCP/IP, and services are properly specified.
- Is the transfer speed correct?
  - Open the network property dialog box in control panel to specify the link speed and duplex value the same as the value specified for HUB.

**The Telnet Service is not installed.**

- Adjust the computer name to 14 characters or less, and then install the Telnet Service according to <How to install the Telnet Service>.

<How to install the Telnet Service>

1. Click [Run] on Start menu.
2. Type "tntsvr /service" in the [Open] box, and click [OK].
3. Click Start menu, point to [Control Panel] and click [Computer Management] and then click the [Services] to specify whether the Telnet Service is registered.

\* When the installation of Telnet Service is finished, there is no problem if the computer name is set to 15 characters or more.

**Wake-On-LAN Function**

The Remote Power ON/OFF function (Wake-On-LAN) is disabled immediately after the AC power is turned on.

Start Windows 2003 once, perform the steps below, and then shut down the system. After restart, the Remote Power On/Off function is enabled unless the AC power is turned off.

1. Select [Start] - [Administrative Tools] - [Computer Management].
2. Select [Device Manager] - [Network Adapter], and double-click [Intel(R) PRO/1000 82566DM-2 Gigabit Network Connection]. Set as follows in the [Detail] tab.

PME: [ON]

Wake On: [Magic Packet]

**Fail to start the OS with the /3GB switch**

→ System often fails to start the OS with the /3GB switch.

In this case, please adjust the capacity of the user mode area using the /userva switch in reference to the following URL.

<http://support.microsoft.com/kb/316739/en>

## Problems with NEC EXPRESSBUILDER

When the server is not booted from the NEC EXPRESSBUILDER DVD, check the following:

- Did you set the NEC EXPRESSBUILDER during POST and restart the server?
  - If you do not set the NEC EXPRESSBUILDER during POST and restart the server, an error message will appear or the OS will boot.
- Is BIOS configuration correct?
  - The boot device order may be specified with the BIOS SETUP utility of the server. Use the BIOS Setup utility to change the boot device order to boot the system from the optical disk drive first.
  - <Menu to check: [Boot]>
- If [OS installation \*\*\*default\*\*\*] is selected at BOOT Selection screen, following message is displayed.

After this message appears, check the error and take the appropriate corrective action according to the message listed in the table below.

Message	Cause
This EXPRESSBUILDER version was not designed for this computer. Insert the correct version and click [OK]. (When you click [OK], the computer reboots.)	This NEC EXPRESSBUILDER version is not designed for this server. Execute the NEC EXPRESSBUILDER on the compliant server.
EXPRESSBUILDER could not get the hardware parameters written in this motherboard. This version is not designed for this computer or the motherboard may be broken. (When you click [OK], the computer reboots.)	This message is shown when NEC EXPRESSBUILDER could not find system-specific information because of mother board exchange and so on.
The hardware parameters written in this motherboard are incorrect. This version is not designed for this computer or the motherboard may be broken.	

---

## Problems with Express Setup

**Following message appeared when you tried to install Express Setup to the hard disk drive that has smaller capacity than the specified partition size:**

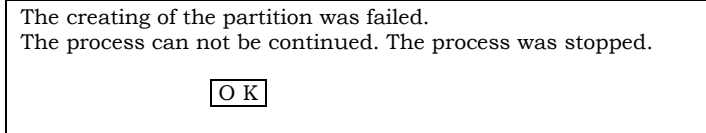

- Cannot continue the setup.  
Specify smaller partition size than the capacity of connected hard disk drive, and then retry the setup.

### **Express Setup terminated and asks to input setup information.**

- There are some errors on the specified setup information.  
Follow the instruction to input the correct value. It is not necessary to cancel the installation.

### **The system partition is created by size smaller than specified value.**

- In ExpressSetup, there are some cases that the system partition is created by size about 8MB smaller than specified size.  
It is not a problem in operating the system.

### **Specified to join the Domain, but the system is installed as Workgroup.**

- When the setup fails to join the Domain during the installation, it will install the system as Workgroup. Open [System] in Control Panel to specify joining the Domain.

**Changed the giga driver speed from 1000M bps to 100M bps. But the changed speed is not properly displayed in Network Details of NEC ESM PRO DataViewer (still 1000M bps is indicated):**

- It does not affect the operation of LAN driver.

### **Fail to start Parameter File Creator:**

- Parameter File Creator requires to run by "Microsoft(R) HTML Application host".  
If Parameter File Creator does not start, associate the file type with "Microsoft(R) HTML Application host" via following process.
  - 1) Click [Run] on Start menu.
  - 2) Type "%windir%\system32\mshta.exe /register" in the [Open] box, and click [OK].

---

## Problems with RAID System Configuration

Check the following if the server configuring a RAID System does not operate properly or a utility does not operate correctly. If a relevant item is found, follow the processing method.

### Fail to install the OS:

- Is the RAID Controller configured?
  - Provide proper configuration for the RAID Controller by using the LSI Software RAID Configuration Utility.

### Fail to start the OS:

- Is the BIOS of the RAID Controller changed?
  - Set the BIOS correctly by using the LSI Software RAID Configuration Utility.
- Does POST recognize the RAID Controller?
  - After making sure that the RAID Controller is connected correctly, then power on the server.  
  
If the RAID Controller is not recognized correctly despite correct connection, the RAID Controller may be failed. Contact your service representative.

### Rebuild fails:

- Is the capacity of the hard disk drive to be rebuilt sufficient?
  - The hard disk drive to be rebuilt should have the same capacity of the failed had disk drive.
- Is RAID0 configured?
  - RAID0 has no data redundancy, therefore, Rebuild is disabled in the RAID0 configuration. Replace the failed hard disk drive, create the configuration data again and initialize the hard disk drives. Then recover the data by using backup data.

### Auto rebuild fails:

- Was a sufficient time taken for hot swap of hard disk drives?
  - To allow the auto rebuild to operate correctly, it should take 90 seconds or longer for the interval between the removal of the failed hard disk drive and the installation of a new hard disk drive.
- Is configuration correct?
  - Check the setting of auto rebuild by using the LSI Software RAID Configuration Utility. <Menus to check: Top menu - [Objects] - [Adapter] - [Auto Rebuild]>

**A hard disk drive fails:**

→ Contact your service representative.

**Physical device is not correctly displayed on Universal RAID Utility**

→ If you use LSI Embedded MegaRAID™, a part of information on a physical device is not correctly displayed on Universal RAID Utility.  
It is no problem.

**Fail to access to USB devices on Windows Server 2003 x64 Edition or Windows Server 2003:**

- ❑ Did you apply [Hotfix for Windows x64 "KB921411"] or [Hotfix for Windows Server 2003 (KB921411)] prior to the "Updating the System" process?

Specify whether "!" is displayed or not on the USB root hub.

<verification process>

Click Start menu, right-click [My Computer], and click [Manage] to start Device Manager.

And then, select [Device Manager] from the left side window.

→ If "!" is displayed on the USB root hub, apply the Hotfix according to the "Recovery process".

For "Recovery process", see Appendix D or Appendix E for details.

**Fail to restart the system with the message means "pci.sys missing or corrupt" after you executed "Updating the System" process to Windows Server 2003 x64 Edition or Windows Server 2003:**

- ❑ During the application of the ChipSet driver by "Updating the System" process, the driver for the USB device may be deleted.

Follow the process detailed below.

- (1) Start the Recovery console.
- (2) Copy "<Systemdrive>\system32\dlldata\pci.sys" to under "<Systemdrive>\system32\drivers".
- (3) Exit the Recovery console, and restart the system.
- (4) Refer to "Recovery process" and follow to the process detailed to apply [Hotfix for Windows x64 "KB921411"] or [Hotfix for Windows Server 2003 (KB921411)] and "Updating the System".

For "Recovery process", see Appendix D or Appendix E for details.

---

## Problems with Windows Autorun Menu

### Cannot read online document:

- Do you have Adobe Reader installed correctly in your system?
  - Some online documents are supplied with PDF format. To read the document of PDF format, Adobe Reader is required in your system.
- Is the operating system Windows XP SP2?
  - With Windows XP SP2, the following information may appear in browser.

"To help protect your security, Internet Explorer has restricted this file from showing active content that could access your computer. Click here for options..."

    1. Click the Information Bar.  
The shortcut menu appears.
    2. Click [Allow blocked content].  
The security alert dialog box appears.
    3. Click [Yes] on dialog box.

### The menu fails to appear:

- Is your system Windows XP or later, or Windows 2003 or later?
  - The Windows Autorun menu is supported by Windows XP/Windows 2003 or later.
  - If your system runs on Windows Autorun Menu on Windows 2000 system, you need to setup IE6.0 before using Windows Autorun Menu.
- Is **Shift** pressed?
  - Setting the DVD/CD-ROM with **Shift** pressed down cancels the Autorun feature.
- Is the system in the proper state?
  - The menu may not appear depending on the system registry setting or the timing to set the DVD/CD-ROM. In such a case, start the Explorer and double-click the icon of the optical disk drive.

### Some menu items are grayed-out:

- Is your system environment correct?
  - The menu items are grayed-out when the logon user does not have the authority of the Administrator or the system does not meet the requirements to install the application. Login with the user having the proper authority on the proper system, and try again.

---

## Collecting Event Log

This section describes on how to collect the log of various events that occurred on the server.

---

**IMPORTANT:** If STOP error, system error, or stall occurred, follow the procedure below after restarting the system.

---

1. Click [Management Tool] → [Event Viewer] from the Control Panel.
2. Select the type of the log to collect.  
On [Application Log], the events related to the running application is archived. On [Security Log], the events related to the security is archived. On [System Log], the events occurred at the item which configures Windows system is archived.
3. Click [Save as...] in the [Run] menu.
4. Input the file name of archived log in the [File Name] box.
5. Select the type of the log file you want to save in the [File Type] list box and click [OK].

For more information, refer to Windows Online Help.

---

## Collect Configuration Information

This section describes on how to collect the information on hardware configuration and inside specification.

In order to collect information, "Diagnostic Program" is used.

---

**IMPORTANT:** If STOP error, system error, or stall occurred, follow the procedure below after restarting the system.

---

1. Point to [Settings] in Start menu, and click [Control Panel].  
The [Control Panel] dialog box appears.
2. Double-click [Management Tool], and double-click [Computer Management].  
The [Computer Management] dialog box appears.
3. Click [System Tool] → [System Information].
4. Click [Save as System Information File] in the [Operation] menu.
5. Input the file name to save in the [File Name] box.
6. Click [Save].

---

## Collecting Dr. Watson Diagnostic Information

Dr. Watson collects diagnostic information related to application errors. The location to save the information can be specified as you like. For more information, see Chapter 5.

---

## Memory Dump

If an error occurs, the dump file should be saved to acquire necessary information.

If you saved the dump to DAT, write down that it is saved as "NTBackup" or "ARCServe" on the label. You can specify the location to save the diagnostic information as you like. For more information, see "Specifying Memory Dump (Debug Information (see Chapter 5 for detail))".

---

### IMPORTANT:

- Consult with your service representative before dumping the memory. Dumping the memory while the server is in the successful operation may affect the system operation.
  - Restarting the system due to an error may display a message indicating insufficient virtual memory. Ignore this message and proceed. Restarting the system may result in dumping improper data.
-

## **RECOVERY FOR WINDOWS SERVER 2003 X64 EDITIONS AND WINDOWS SERVER 2003**

If the system fails to start by some reasons, recover the system with the recovery console. However, recovery using this method should be performed only by system administrator or a user who has an expert knowledge.

See Online Help for details.

---

## MAINTENANCE TOOLS

The Maintenance Tools is a tool of this product prevention to maintain, and to analyze the trouble.

---

### Starting Maintenance Tools

The Maintenance Tools is started according to the following procedure.

1. Turn on peripheral devices and the server in this order.
2. Insert the NEC EXPRESSBUILDER DVD supplied with your server into the optical disk drive of your server.
3. Press **Ctrl, Alt, and Delete** to reboot the server from the NEC EXPRESSBUILDER.  
(You may also turn off and then on again to reboot the server.)

System boots up displaying Boot Selection menu.

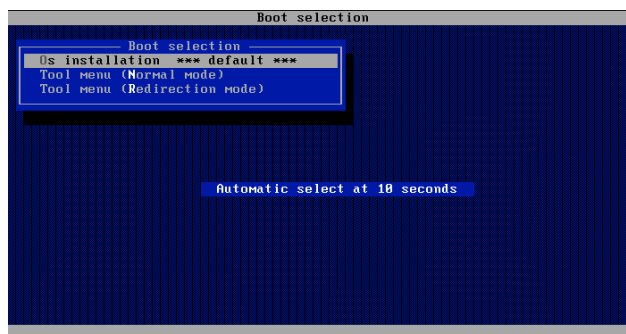

---

**IMPORTANT:** An initial selection of the menu is "Os installation".  
"Os installation" starts by the automatic after the Boot Selection menu is displayed.

---

4. When a local console is used, "Tool menu (Normal mode)" is selected.  
Moreover, "Tool menu (Redirection mode)" is selected when using it with remote console.

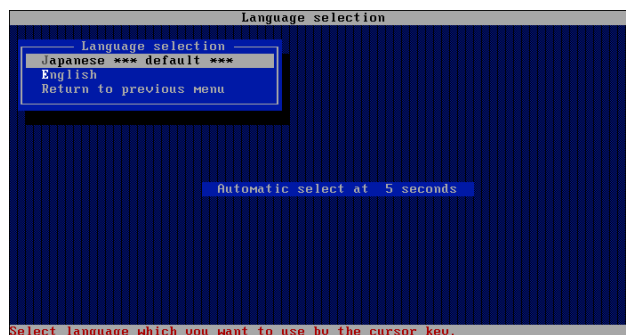

**IMPORTANT:** An initial selection of the menu is "Japanese".  
"Japanese" starts by the automatic operation when the operation is not done for five seconds after the Language Selection menu is displayed.

5. "English" is selected.

The tool menu is displayed.



**When you use a local console**

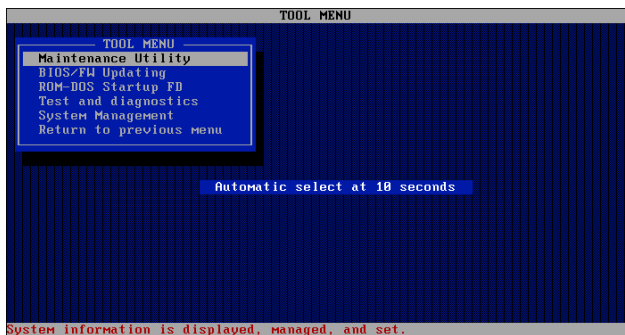

**When you use a remote console**

6. Each tool is selected, and it starts.

---

## Function of Maintenance Tools

The following functions can be executed in the Maintenance Tools.

- Maintenance Utility

The Off-line Maintenance Utility is started in Maintenance Utility. The Off-line Maintenance Utility is an OS-independent maintenance program. When you are unable to start the OS-dependent NEC ESMPRO to troubleshoot a problem, the Off-line Maintenance Utility can be used.

---

### IMPORTANT:

- The Off-line Maintenance Utility is intended for use of your service representative. The NEC EXPRESSBUILDER DVD you have created contain a file that describes operation of the utility, but do not attempt to use the utility by yourself. Contact your service representative and follow instructions.
  - See the on-line help for details of the Off-line Maintenance Utility. For further information, ask your service representative.
- 

The Off-line Maintenance Utility provides the following features.

- BIOS Setup Viewer

Provides the functions to export the current configuration data defined with the SETUP utility to a text file.

- System Information Viewer

Provides the functions to view information on the processor and the BIOS and export it to a text file.

- System Information Management

Provides the function to make a back-up copy of your data.

Without the backup data, the system-specific information and/or configuration may not be restored.

Only the authorized personnel is allowed to restore the backup data.

- BIOS/FW Updating

This menu allows you to update the software module such as BIOS and firmware of the server by using the update disk (3.5-inch floppy disk) that is distributed from NEC customer service representative.

After rebooting the system, an update program is started automatically from floppy disk, and the various BIOS and firmware programs are updated.

---

**IMPORTANT:** Do not turn off the server while the update program is running. If the update processing is discontinued, the system becomes unable to start.

---

- ROM-DOS startup FD

Creates a support disk for starting the ROM-DOS system.

- Test and diagnostics

Execute various tests on the server system to check if the server functions are normal and if the connection between the server and additional board is normal.

After the Test and diagnostics is executed, a system check program assigned to each model starts. See Chapter 7 for details.

- System Management

The parameters of BMC (Baseboard Management Controller) are set for remote control and alert.

This function is not supported in this server.

## RESETTING THE SERVER

If the server halts before starting the OS, press and hold **Ctrl** and **Alt** and press **Delete**. This restarts the server.

---

**IMPORTANT:** Resetting the server clears the DIMM memory and the data in process. To reset the server when it is not frozen, make sure that no processing is in progress.

---

## FORCED SHUTDOWN

Use this function when an OS command does not shut down the server, the POWER/SLEEP switch does not turn off the server, or resetting does not work.

Press and hold the POWER/SLEEP switch on the server for at least four seconds. The power is forcibly turned off. To turn on the power back again, wait approximately 10 seconds after turning off the power (forced shutdown).

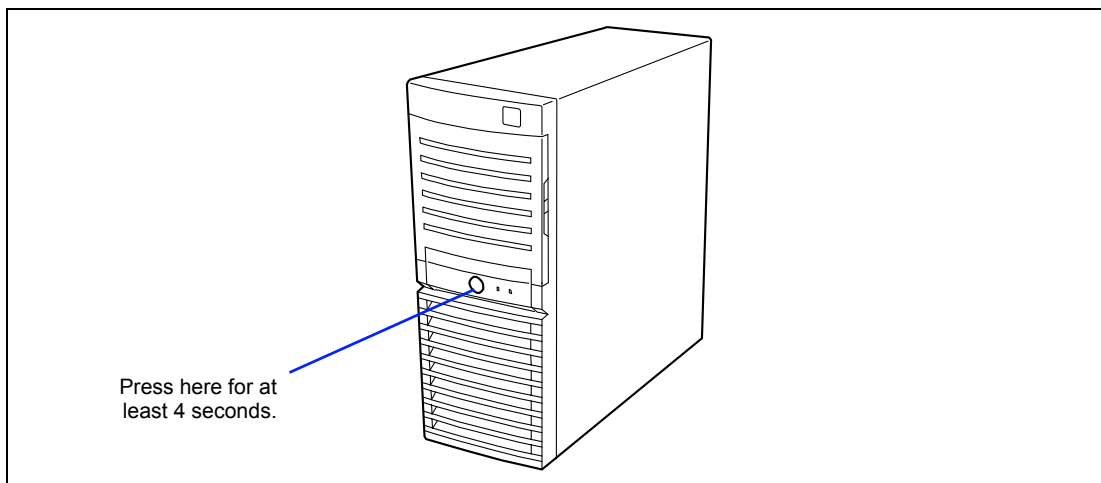

---

### IMPORTANT:

- If the remote power-on function is used, cycle the power once to load the OS, and turn off the power again in the normal way.
  - If the processor is heated excessively, the circuit for protecting expensive components is started. If so, the POWER/SLEEP switch cannot be used to control the power because the system is entered into the reset status. Pull out the power cord and turn off the power. After a while, check the operation environment (including the ambient temperature). Then connect the power cord and turn on the power. It may be necessary to leave the power-off status in the period until the processor is cooled sufficiently (about five minutes in normal).
-

# Chapter 9

---

## Upgrading Your Server

This chapter describes internal optional devices available for the server, procedures for install or removing such optional devices, and notes on using them.







---





**IMPORTANT:**

- Optional devices described in this chapter may be installed or removed by any user. However, NEC does not assume any liability for damage to optional devices or the server or malfunctions of the server resulted from installation by the user. NEC recommends you ask your service representative for installing or removing any optional devices.
  - Use the options and cables approved by NEC. You will be charged by any repair of a malfunction, fault, or defect occurring in a server in which one or more component not approved by NEC are used.
  - Always update the system if the hardware configuration is changed (See Chapter 5 for details).
-

## SAFETY NOTES

Observe the following notes to install or remove optional devices safely and properly.

 <b>WARNING</b>	
     	<p>Observe the following instructions to use the server safely. Failure to follow these instructions may result in death or serious personal injury. See pages 1-3 to 1-8 for details.</p> <ul style="list-style-type: none"><li>■ Do not disassemble, repair, or alter the server.</li><li>■ Do not remove the lithium battery.</li><li>■ Disconnect the power plug before working with the server.</li></ul>

 <b>CAUTION</b>	
  	<p>Observe the following instructions to use the server safely. Failure to follow these instructions may cause a fire, personal injury, or property damage. See pages 1-3 to 1-8 for details.</p> <ul style="list-style-type: none"><li>■ Avoid installation in extreme temperature conditions.</li><li>■ Make sure to complete board installation.</li><li>■ Protect the unused connectors with the protective cap.</li><li>■ Never attempt to lift the server only by yourself.</li></ul>

## STATIC PRECAUTIONS

An electrostatic discharge (ESD) can damage disk drives, option boards, and other components. Electronic device can be easily damaged by static electricity. To prevent damage, observe the following information.

- Wear a wrist strap (an arm belt or anti-static glove).
  - Wear a wrist strap on your wrist.
- Select a suitable work space.
  - Work with the server on the anti-static or concrete floor.
  - When you work with the server on a carpet where static electricity is likely to be generated, make sure take anti-static measures beforehand.
- Use a work table.
  - Place the server on an anti-static mat to work with it.
- Clothe
  - Do not wear a wool or synthetic cloth to work with the server.
  - Wear anti-static shoes to work with the server.
  - Take off any jewels (a ring, bracelet, or wrist watch) before working with the server.
- Handling of components
  - Keep any component in an anti-static bag until you actually install it to the server.
  - Hold a component by its edge to avoid touching any terminals or components.
  - To store or carry any component, place it in an anti-static bag.

## PREPARING FOR INSTALLATION AND REMOVAL

Prepare the installation or removal of a component depending on the following procedure:

1. Shut down the OS.
2. Press the POWER/SLEEP switch to turn off the power of the server. (The POWER/SLEEP lamp goes off.)

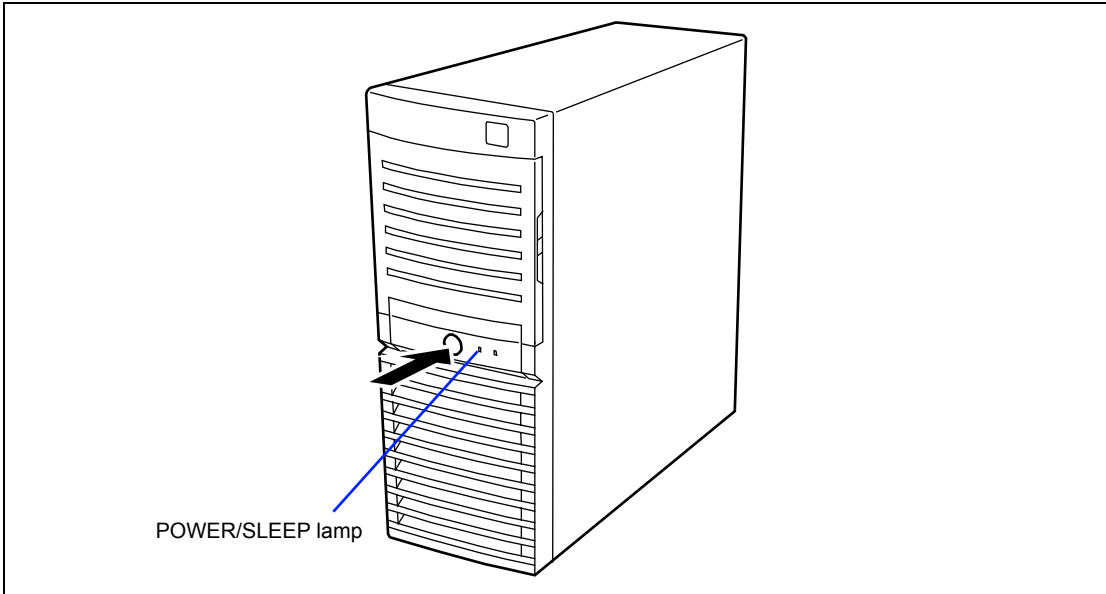

3. Pull out the power cord from the AC inlet on the server.

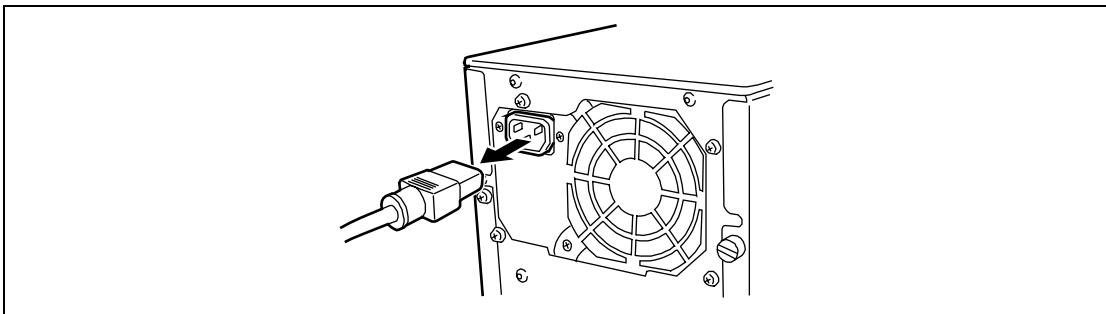

4. Remove all the cables connected to the server on the rear panel.

## INSTALLATION OR REMOVAL PROCEDURE



Install or remove a component from the server in the following procedure.

### Left Side Cover

The left side cover should be removed to access to built-in devices and/or mother board in the server. It is not necessary to remove the right side cover.

### Removal

Remove the left side cover in the following procedure.

 <b>WARNING</b>	
	<p>Observe the following instructions to use the server safely. Failure to follow these instructions may result in death or serious personal injury. See pages 1-3 to 1-8 for details.</p> <ul style="list-style-type: none"><li>■ Disconnect the power plug before working with the server.</li></ul>

1. See the section "Preparing for Installation and Removal" described earlier to prepare.
2. Unlock the left side cover if required.

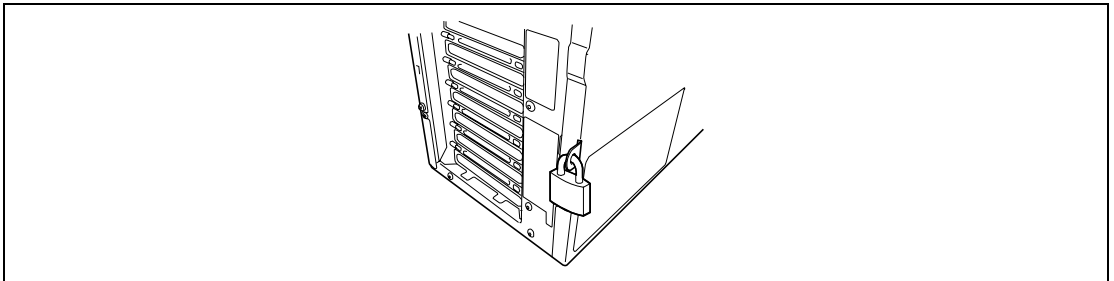

3. Loosen the two screws.

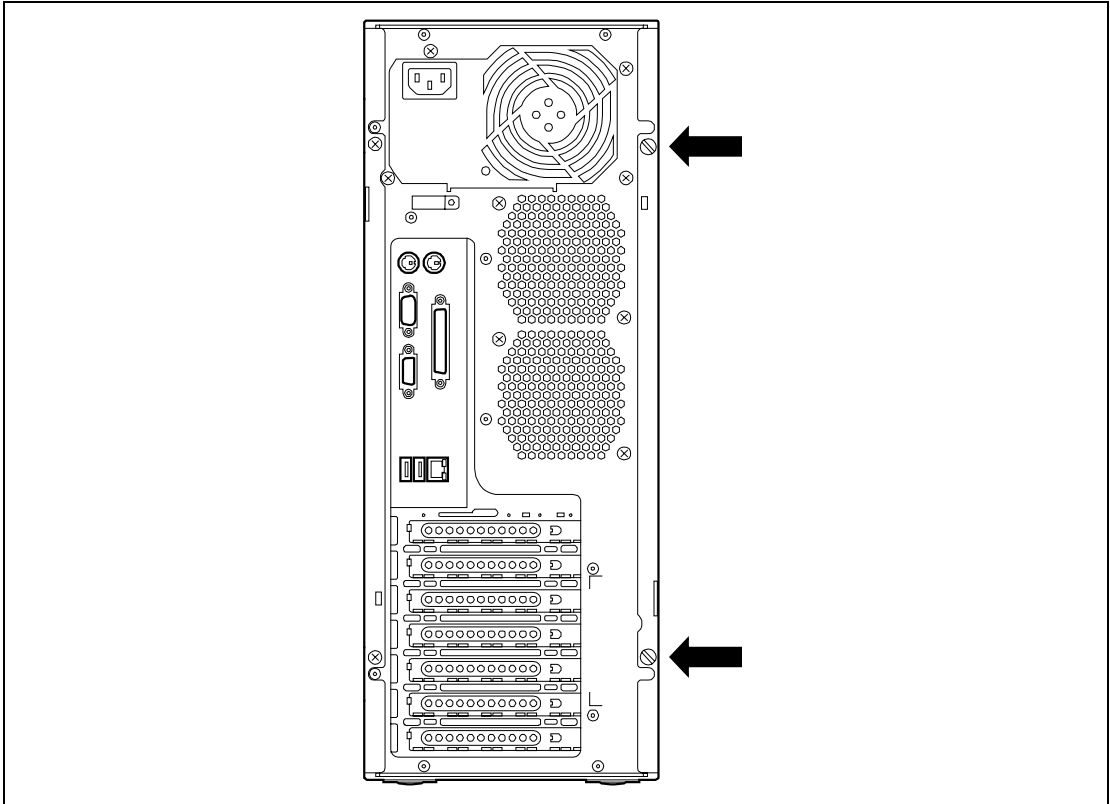

4. Hold the side cover securely to remove it.

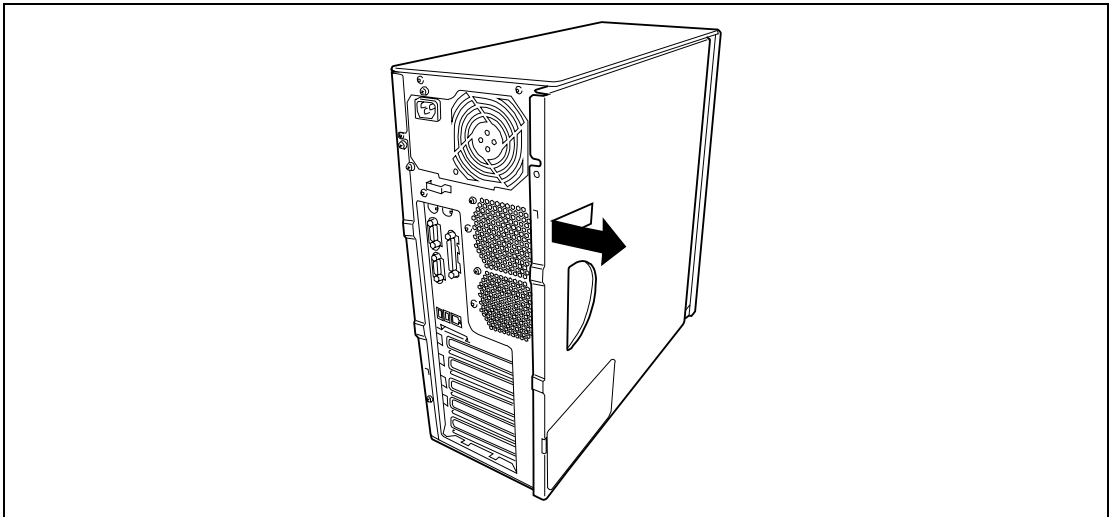

5. Position the server until on its right side.

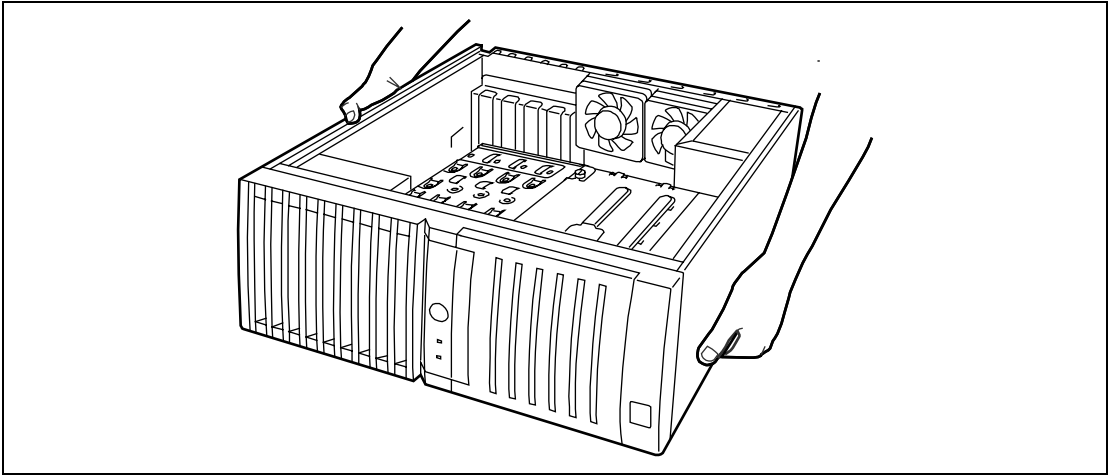

### Installation

The side cover can be installed in the reverse procedure of the removal. Make sure that the hooks on the side cover are inserted into the frames and holes of the server securely.

---

**IMPORTANT:** After one or more optional devices are installed or removed completely, install the removed side cover securely.

---

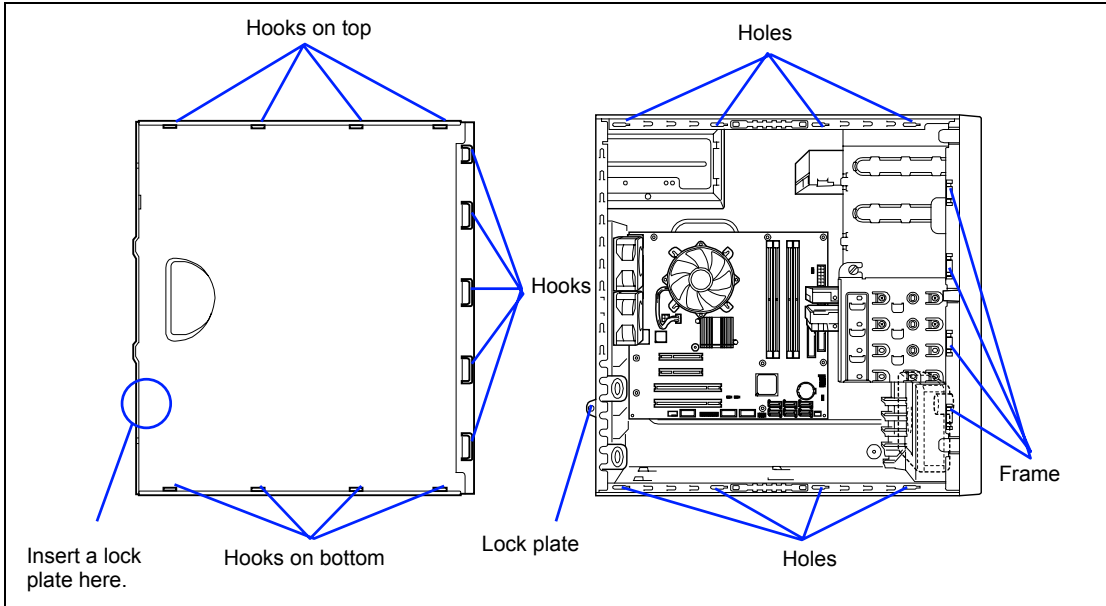

Secure the side cover with two screws removed in the removal procedure.

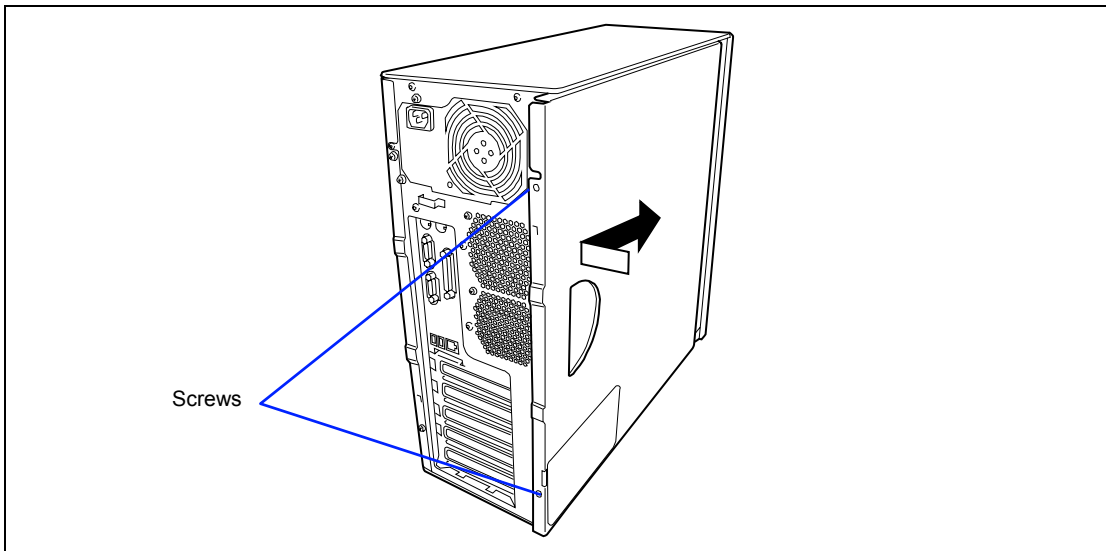

---

## Front Mask

The front mask must be removed to install or remove the hard disk drive and 5.25-inch device.

### Removal

Follow the procedure below to remove the front mask.

1. See the section "Preparing for Installation and Removal" described earlier to prepare.
2. Remove the left side cover as described earlier in this chapter.
3. Pull the release tabs (3) at the left end of the front mask toward you so that the tabs are removed from the frame of the server.

---

**IMPORTANT:** If the tabs are pulled out toward you excessively, the hooks fixing the right end of the front mask will be damaged. Only pull out the tabs a little.

---

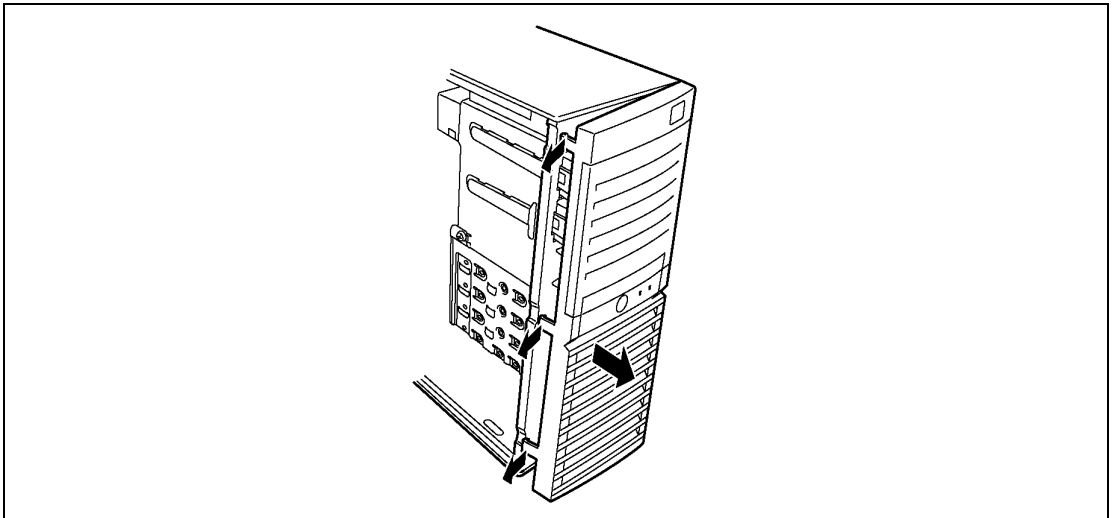

4. Remove the front mask to the left to release the tabs on the front mask from the server.

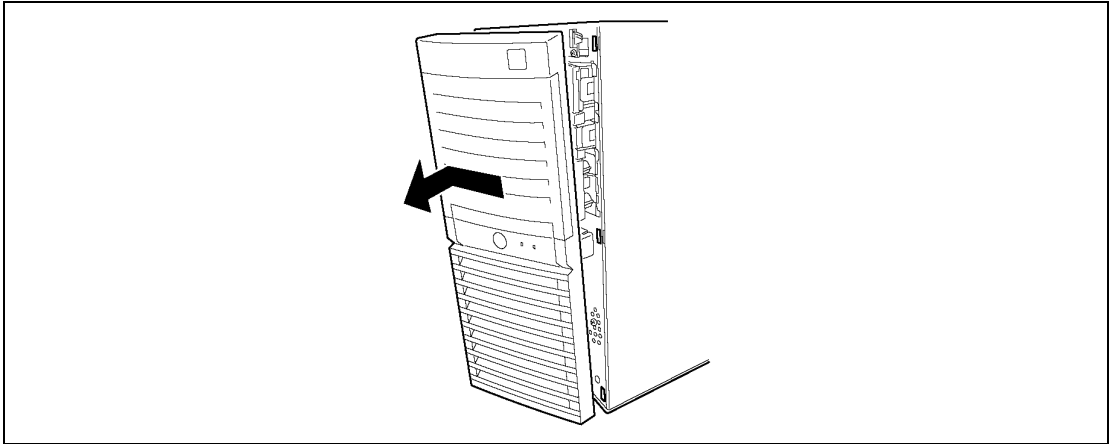

5. Position the server until on its right side.

### Installation

The front mask can be installed in the reverse order of the removal. Insert the three tabs at the right end of the front mask into the holes on the front of the server, press the left end of the front mask to the server, and lock the mask with the release tabs.

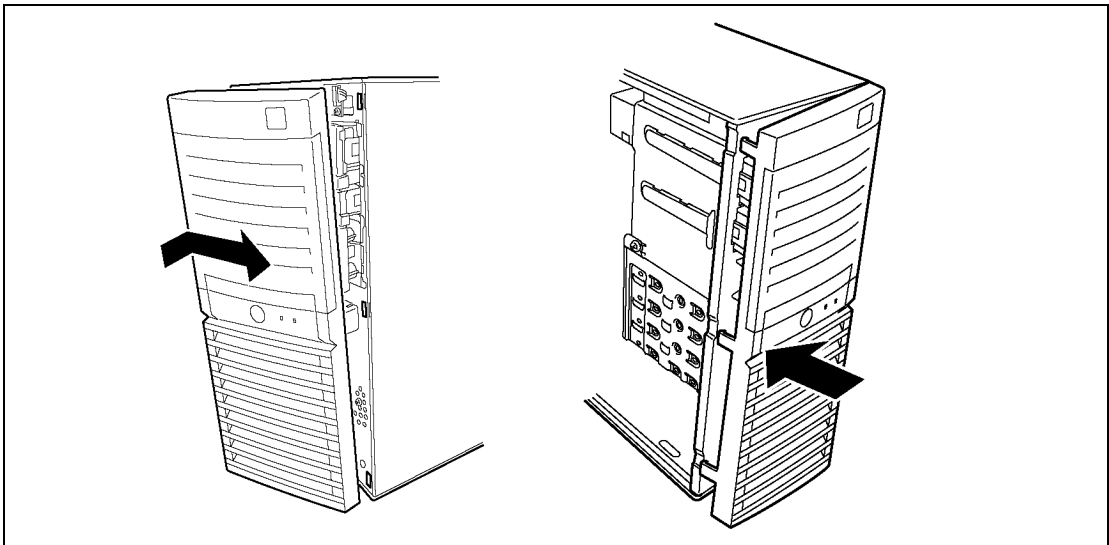

---

## 3.5-inch Hard Disk Drive

The hard disk drive bay may contain up to four SATA hard disk drives.

---

**IMPORTANT:** Do not use any hard disk drive that is not authorized by NEC. Installing a third-party hard drive may cause a failure in the server as well as the hard disk drive. Repair of any failure or damage in the server caused by such a hard disk drive will be charged.

---

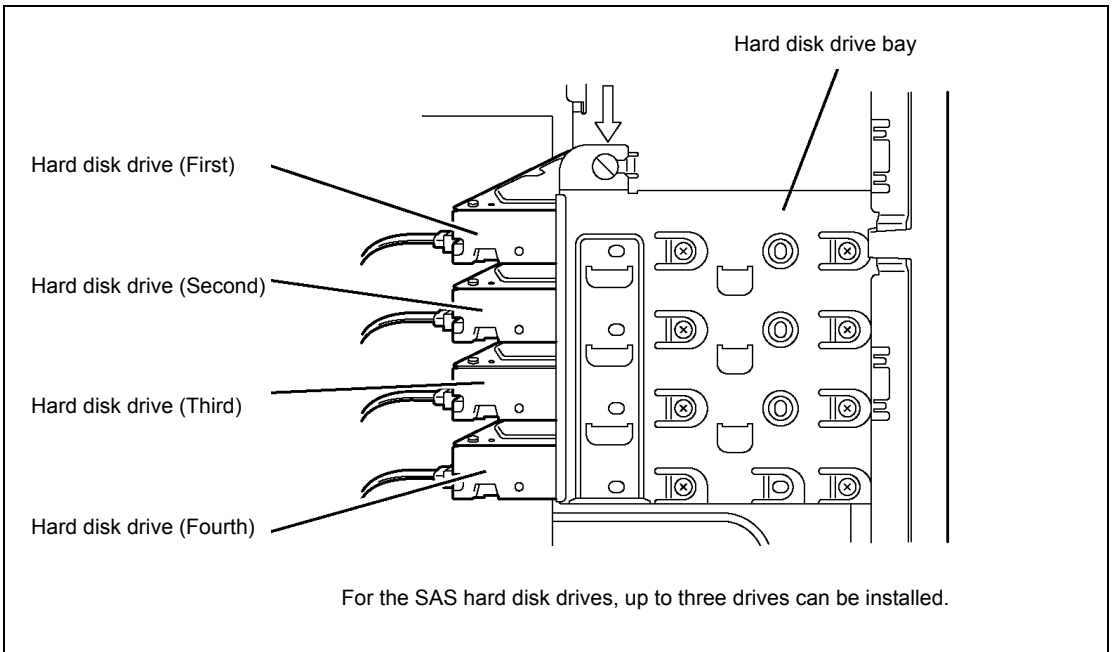

## Installation

Follow the procedure as described below to install 3.5-inch hard disk drives.

1. Configure the operation mode of hard disk drives according to the manual supplied with the hard disk drive.

Hard disk drive	Bay to Install	Serial ATA connector on mother board <sup>*2</sup>
First hard disk drive	Top	Serial ATA connector 1
Second hard disk drive	Upper Middle	Serial ATA connector 2
Third hard disk drive	Lower Middle	Serial ATA connector 3
Fourth hard disk drive	Bottom	Serial ATA connector 4

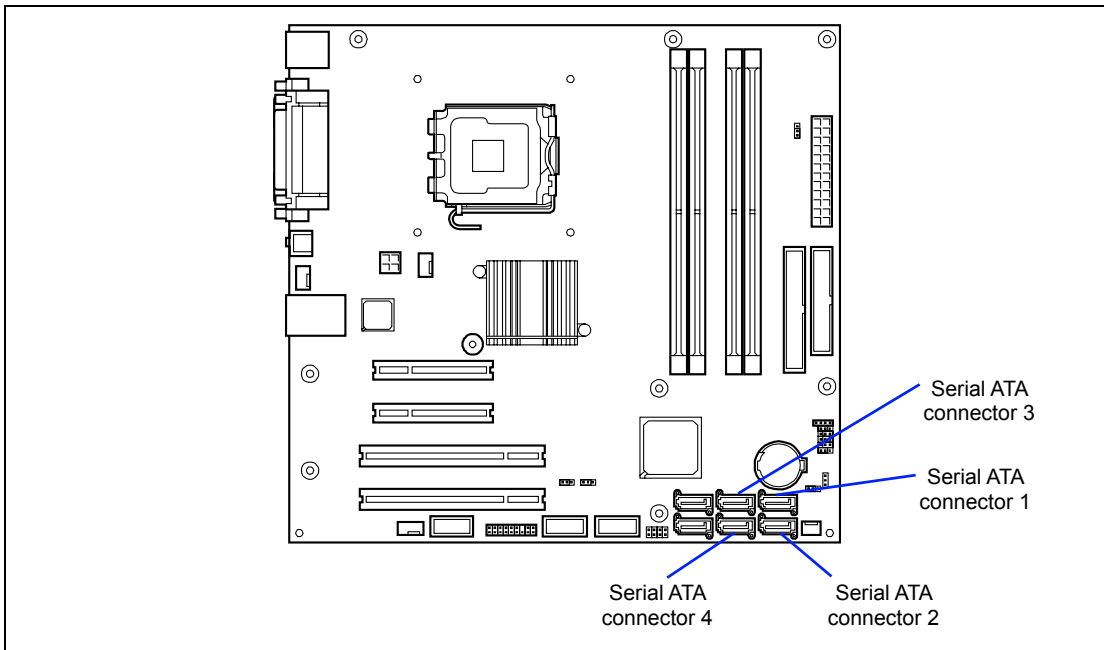

2. See the section "Preparing for Installation and Removal" described earlier to prepare.
3. Remove the left side cover and front mask.
4. Disconnect the power cable, IDE cable, and FDD cable from the mother board.
5. Disconnect the interface cable and power cord from the hard disk drive if connected.

6. Remove the three screws on the front panel securing the hard disk drive bay.

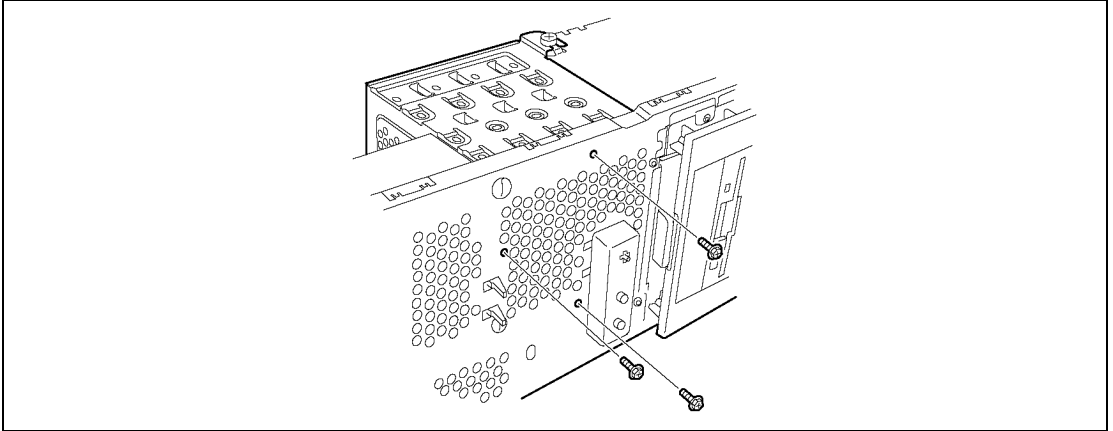

7. Loosen the screws securing the hard disk drive bay.  
Only loosen the screws. They may not be removed.

---

**IMPORTANT:** Loosening the screws causes the hard disk drive bay to be made free. Loosen the screws with the hard disk drive bay held so that they may not be dropped.

---

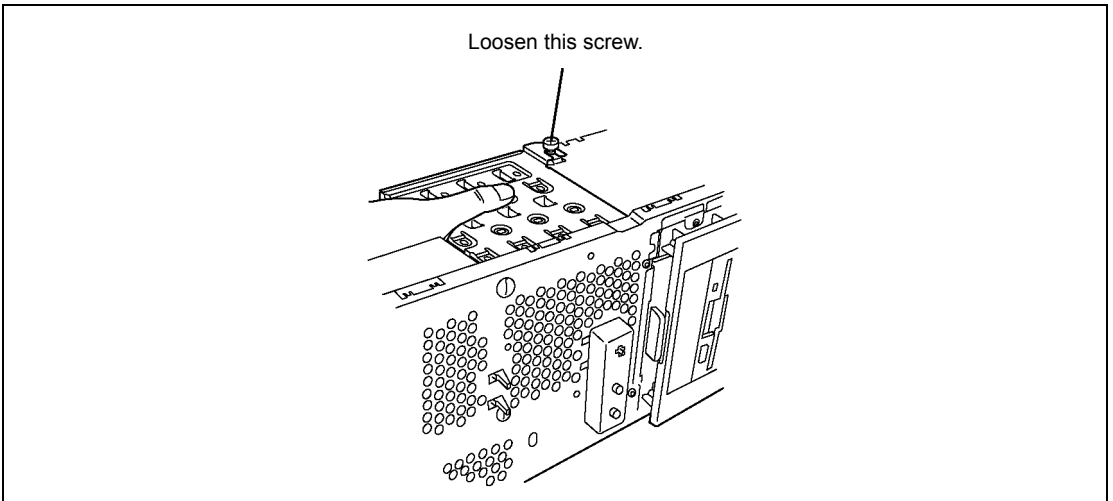

- Slide the hard disk drive bay in the depth of the server only a little to remove the bay.

---

**IMPORTANT:**

- Be careful not to have the hard disk drive bay hit on any components on the mother board.
  - Be careful not to get the hard disk drive bay caught in internal cables.
- 

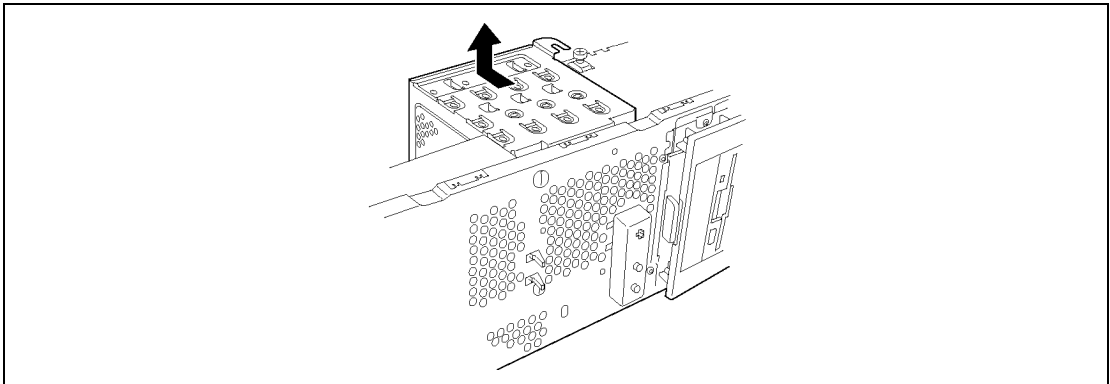

- Place the hard disk drive bay on the anti-static table carefully.
- Hold the hard disk drive with the connector side facing toward you and the board side facing downward and then insert the hard disk drive into the slot slowly and gently.  
Place the hard disk drive so that it is put on the craws (4) of the hard disk drive bay.

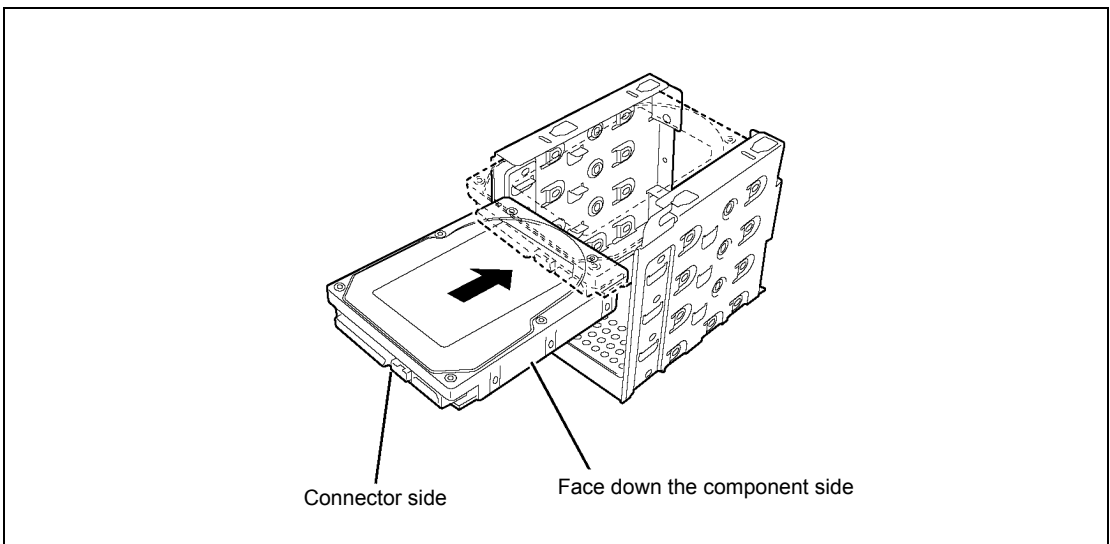

11. Align the screw holes of the hard disk drive with those of the hard disk drive bay and secure the hard disk drive with the screws (4) provided with the hard disk drive.

---

**IMPORTANT:** Use the screws provided with the hard disk drive. If not, use the screws provided with the server to secure it. Using screws longer than the required length may cause the hard disk drive to be damaged.

---

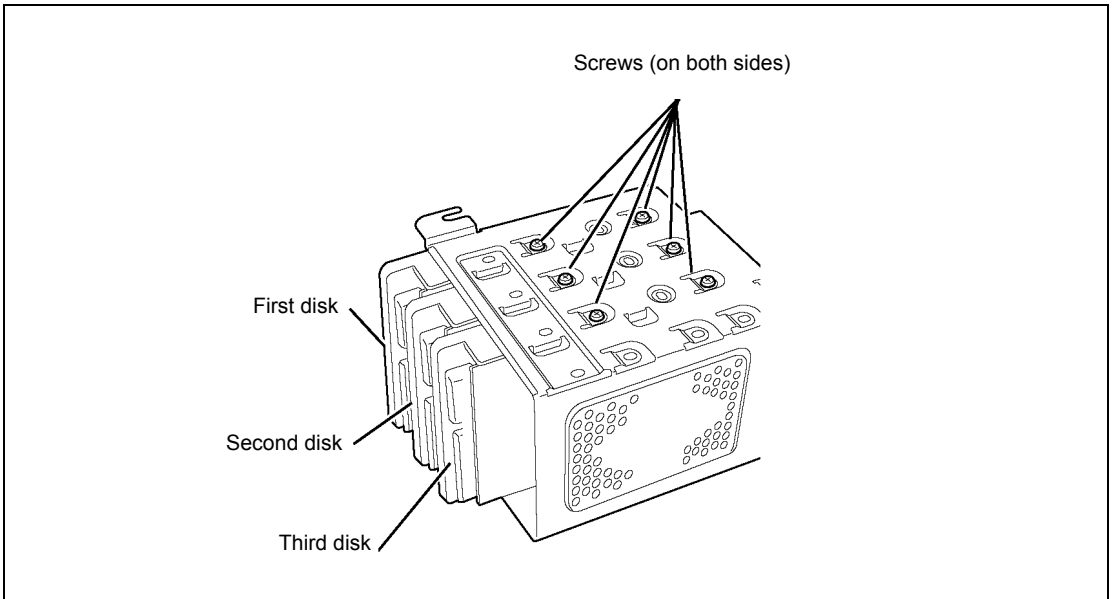

12. Insert the holes of the hard disk drive bay into the hooks of the server with making the hard disk drive bay contact with the frame of the server. In the figure, the PCI guide rail at the bottom is omitted for easy understanding.

---

**IMPORTANT:**

- Be careful not to make the hard disk drive bay hit on any components on the motherboard.
  - When inserting the bay, be careful not to have the hard disk drive damage the cables.
- 

Align the holes of the bay with the hooks of the server.

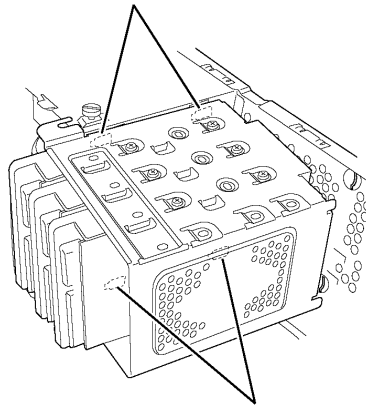

Make the bay contact with the frame of the server.

---

**NOTE:** Insert the hooks on the server into the holes on the hard disk drive bay and then slide the hard disk drive bay to the front of the server.

---

Hooks on which hard disk drive bay is hung

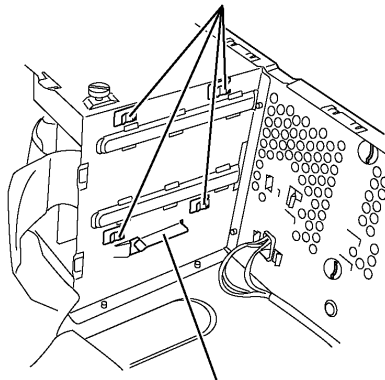

<Server side> Plate on which hard disk drive bay is placed

13. Slide the hard disk drive bay to the front of the server.

---

**NOTES:**

- Make sure that the screw securing hooks on the hard disk drive bay are hang on the screws on the server. Also make sure that the craws on the hard disk drive bay are inserted to the holes on the front of the server.
  - Make sure that all signal cables are not jammed between the server chassis and hard disk drive bay.
- 

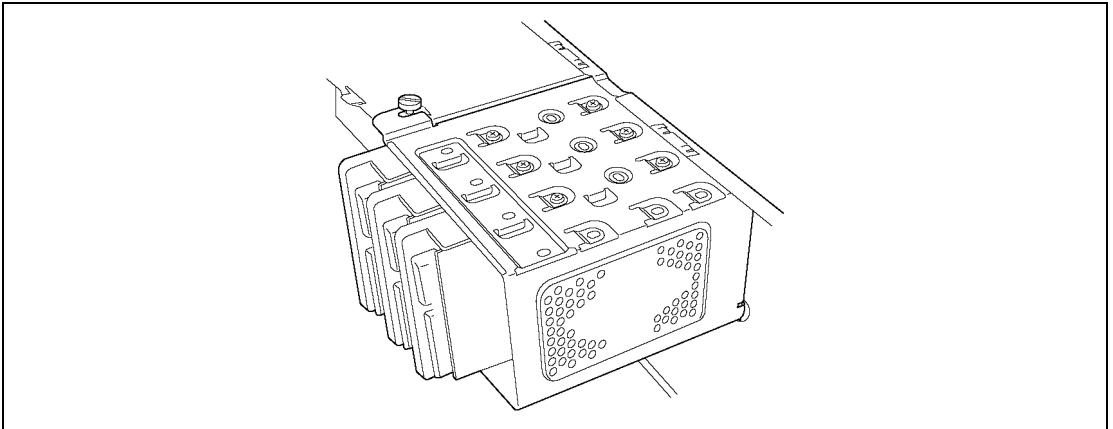

14. Tighten the screws loosened in step 7 and install the three screws removed in step 6.
15. Connect cables removed in step 4.
16. Assemble the server.
17. Run BIOS SETUP utility and check to see that the hard disk drive is correctly recognized. See Chapter 4 for details.

## Use of Internal Hard Disk Drives in the RAID System

This section describes how to use hard disk drives installed in the drive bays in the RAID System.

---

### IMPORTANT:

- Making hard disk drives in the RAID System or changing the RAID level initializes hard disk drives. If the hard disk drive to be configured in the RAID System has your valuable data stored, make sure to make a backup copy of the data in another hard disk drive before installing the RAID Controller and configuring the RAID System.
  - You can configure a logical drive with a single physical device.
  - Use hard disk drives of the same capacity and performance (e.g., revolution) for each pack to configure them in the RAID System.
- 

### NOTES:

- Make sure of RAID levels and hard disk drives available for the RAID Controller to choose an appropriate controller.
  - A Logical Drive except for RAID0 increases disk reliability. However, the actually available capacity becomes smaller than the total hard disk drive capacity in the Logical Drive.
- 

You can build a RAID System by using the Onboard RAID Controller (LSI Embedded MegaRAID, software) or optional RAID Controller (N8103-116/117, hardware).

### Onboard RAID Controller (LSI Embedded MegaRAID)

RAID Controller is factory embedded in your mother board. Setting RAID configuration jumper switch allows internal hard disk drives to be recognized as RAID drives. Set the LSI Embedded MegaRAID jumper switch as shown in the figure below.

**NOTE:** By the shipping default, RAID System is set to "Disabled". If you configure RAID system by using the hardware controller, leave this setting as "disabled".

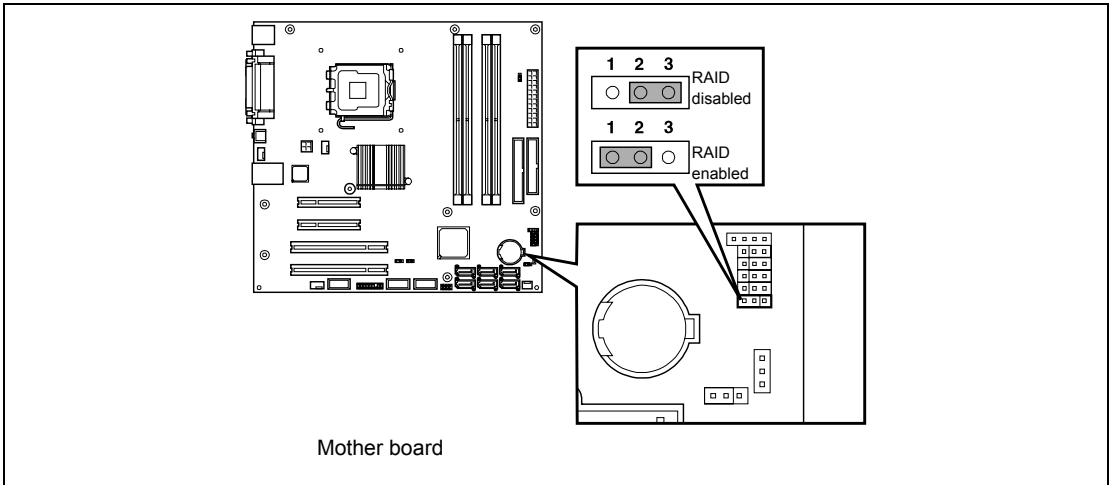

Use LSI Software RAID Configuration Utility to configure the RAID System. See Chapter 4 for details.

## Optional RAID Controller (N8103-116/117)

Your server can include the optional RAID Controller (N8103-116/117). The optional RAID Controller can control the internal hard disk drives as the RAID System. To use the hard disk drives in a RAID System, reconnect the hard disk drive interface cable on the mother board.

At the factory, the interface cable is connected to the serial ATA connector on the mother board. Refer to the manual coming with optional RAID Controller (N8103-116/117) for details.

---

**IMPORTANT:** The RAID Controller board is extremely sensitive to static electricity. Make sure to wear the wrist strap (an arm belt or anti-static glove), and discharge static electricity from your body before handling the RAID Controller. Do not touch the RAID Controller terminals or on-board parts by a bare hand or place the RAID Controller directly on the non-anti-static table. For static notes, see the section "Static Precautions" described earlier.

---

---

**NOTE:** Before installing an optional RAID Controller, run the SETUP utility, select [Advanced] → [PCI Configuration], and confirm that [Enabled] is set for the parameter [PCI Slot x Option ROM] (x: PCI slot number).

---

## Installation

See "PCI Board" in this chapter and manual that comes with the optional RAID Controller for the installation of a RAID Controller (N8103-116/117).

---

**IMPORTANT:** When the RAID Controller is connected, the boot priority specified in BIOS SETUP utility must be eighth or younger. If specified ninth or later, the configuration menu of RAID Controller will fail to start.

---

## Removal

Remove the optional RAID Controller in reverse order of the installation steps.

**Notice**

Observe the following notes on configuring a RAID System:

- The installed hard disk drives (SAS drives or SATA drives) must the same capacity and the same rotational speed. (The minimum number of required disks depends on the configuration of RAID (Redundant Arrays of Inexpensive [Independent] Disks).)
- Select/set a RAID level .  
Onboard RAID controller: RAID0, RAID1, or RAID10  
Optional RAID conteroller: RAID0, RAID1, RAID5, or RAID6

When installing a system in an internal hard disk drive, you should use "Express Setup" to perform all the procedures for RAID System configuration, OS installation, and then OS setup.

Use Express Setup even when not installing a system. Start Express Setup, select [OS Selection] → [Others]. The installer automatically performs all the procedures for RAID System configuration, and then maintenance utility installation.

When making the setup in manual mode, use the RAID System configuration utility in the chip on the board. You can start the utility during execution of POST that automatically starts immediately after you turn on the server power switch. For details, see the online document in the NEC EXPRESSBUILDER DVD provided with the server. For details on the data transfer rate, RAID, and RAID System configuration, see the manual provided with the RAID Controller as well as the online document.

---

**IMPORTANT:**

- When N8103-116/117 is installed, do not let the system enter hibernation or standby mode.
  - Configuring RAID System by SATA hard disk drives together with SAS hard disk drives is not permitted.
-

## Removal

Follow the procedure as described below to remove 3.5-inch hard disk drives.

---

**IMPORTANT:** About data on the hard disk drive

Be sure to take appropriate measures not to leak important data (e.g., customers' information or companies' management information) on the removed hard disk drive to any third parties.

Data seems to be erased when you empty "Recycle Bin" of Windows or execute the "format" command of the operating system. However, the actual data remains written on the hard disk drive. Data not erased completely may be restored by special software and used for unexpected purposes.

It is strongly recommended that the software or service (both available at stores) for data erasure should be used in order to avoid the trouble explained above. For details on data erasure, ask your sales representative.

---

1. See the section "Preparing for Installation and Removal" described earlier to prepare.
2. Remove the left side cover and front mask.
3. Follow Steps 3 through 8 of the installation procedure to remove the disk bay.
4. Follow Steps 9 and 10 of the installation procedure to remove the hard disk drive.
5. Reassemble the server.

---

## PCI Board

The server is equipped with five slots for installing PCI boards.

---

### IMPORTANT:

- Any PCI board is easily affected by static electricity. Make sure to wear the wrist strap (an arm belt or anti-static glove), and discharge static electricity from your body before handling the PCI board. Do not make bare hands contact with terminals and components on the PCI board. In addition, do not put the PCI board on a non-anti-static desk directly. See "Static Precautions" in this chapter for details of the static electricity.
  - The long-sized board (full-length board) can be installed only to the PCI slots #3 or #4. Care must be taken to avoid damage to the components on the mother board when installing the long-sized board.
- 

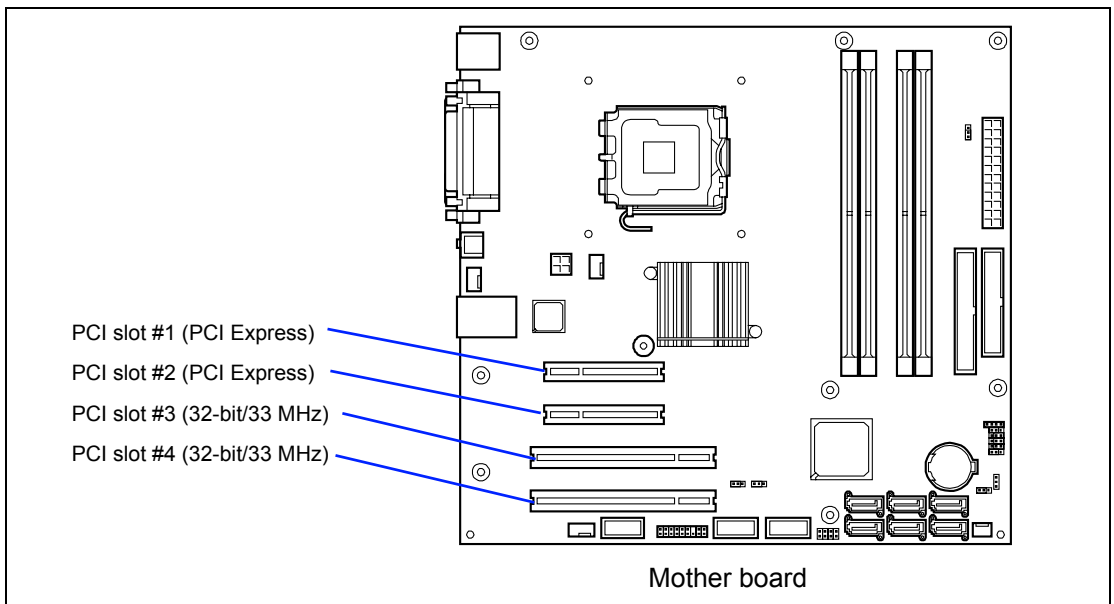

*Slots to install the PCI board*

N code	Product name	Slot (Bus A)	Slot (Bus B)	Slot (Bus C)		Remarks
		PCIe #1	PCIe #2	PCI #3	PCI #4	
	PCI slot capability	x8 lane	x4 lane	32-bit/ 33MHz		
	Slot size	Full-height				
	PCI board type	x8 socket		5V		
Available board size	Short		Long			
N8103-95	SCSI controller (64-bit/66MHz PCI)	-	-	√	√	-
N8103-75	SCSI controller (64-bit/133MHz PCI-X)	-	-	√	√	Cannot co-exist with N8103-107.
N8103-107	SCSI controller (PCI EXPRESS (x1))	√	√	-	-	Cannot co-exist with N8103-75.
N8103-116	RAID controller (128MB, RAID 0/1) (PCI EXPRESS (x8))	√	√	-	-	1 max. Cannot co-exist with N8103-117.
N8103-117	RAID controller (128MB, RAID 0/1/5/6) (PCI EXPRESS (x8))	√	√	-	-	1 max. Cannot co-exist with N8103-116.
N8104-111	100BASE-TX adapter (32-bit/33MHz PCI)	-	-	√	√	-
N8104-119	1000BASE-T adapter (64-bit/133MHz PCI-X)	-	-	√	√	1 max. Cannot co-exist with N8104-112.
N8104-120	1000BASE-T adapter (2 ch) (64-bit/133MHz PCI-X)	-	-	√	√	
N8104-126	1000BASE-T adapter (PCI EXPRESS (x1))	√	√	-	-	Teaming with another N8104-126 is allowed. Teaming with any other NIC is not allowed. Cannot co-exist with N8104-112.
N8104-121	1000BASE-T adapter (2ch) (PCI EXPRESS (x4))	-	√	-	-	Teaming with another N8104-121 is allowed. Teaming with any other NIC is not allowed. Cannot co-exist with N8104-112.
N8104-125	1000BASE-T adapter (4ch) (PCI EXPRESS (x4))	√	√	-	-	1 max. Teaming with any other NIC is not allowed. Cannot co-exist with N8104-112.
N8104-112	1000BASE-SX adapter (2ch) (64-bit/133MHz PCI-X)	-	-	√	√	1 max. Cannot co-exist with N8104-119/126/120/121/125.
N8117-01A	Additional RS232C connector kit	√	√	√	√	1 max.

√: Available, -: Unavailable

## Installation

Install the board to be connected to the PCI board slot depending on the following procedure. Refer to the manual provided with the board.

1. Before the installation, set the switches and jumpers on the installed board appropriately referring to the manual provided with the board, if necessary.
2. See the section "Preparing for Installation and Removal" described earlier to prepare.
3. Remove the left side cover.
4. Press the tabs for the PCI board retention springs one by one to release the lock. Push each tab to the depth of the server lightly and then push it to the mother board. A click occurs to release the lock.

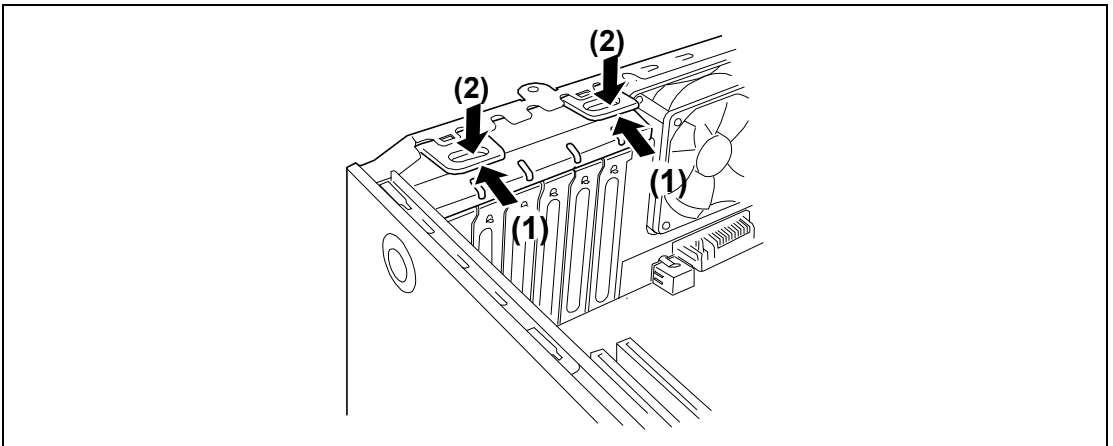

5. Remove the PCI board retention springs from the server.

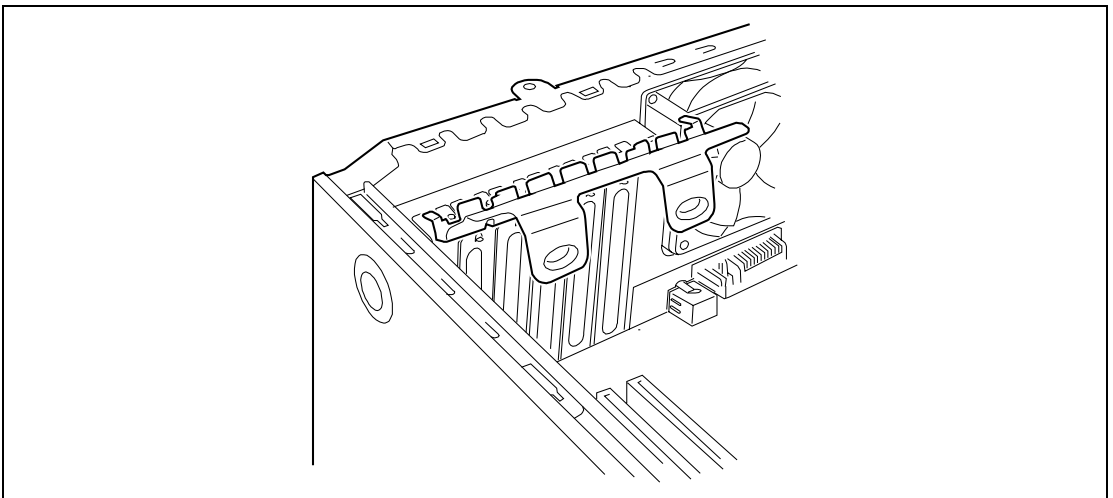

6. Remove the additional slot cover at the same location (height) as the installation slot.

---

**IMPORTANT:** Save the removed slot cover carefully.

---

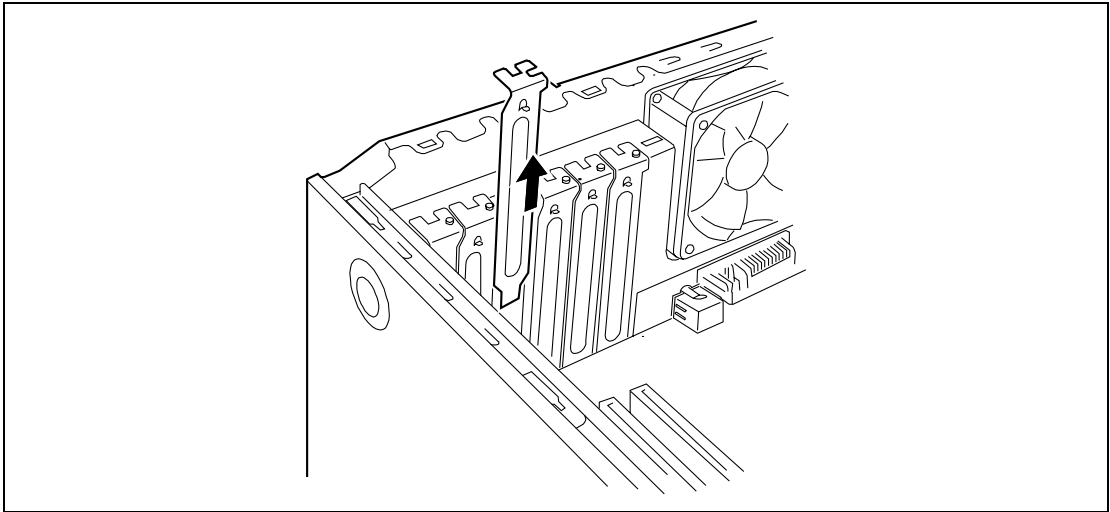

7. Make the component side of the board face the bottom of the server, put the rear panel of the board on the frame spring securely, and push the board fully so that the board connection port is certainly connected to the slot.

For a long-sized board, align the board with the groove of the guide rail on the front of the server and then connect the board to the slot.

---

**IMPORTANT:** If the board cannot be installed well, remove the board once and then install it again. Note that adding an excess force to the board may cause it to be damaged.

---

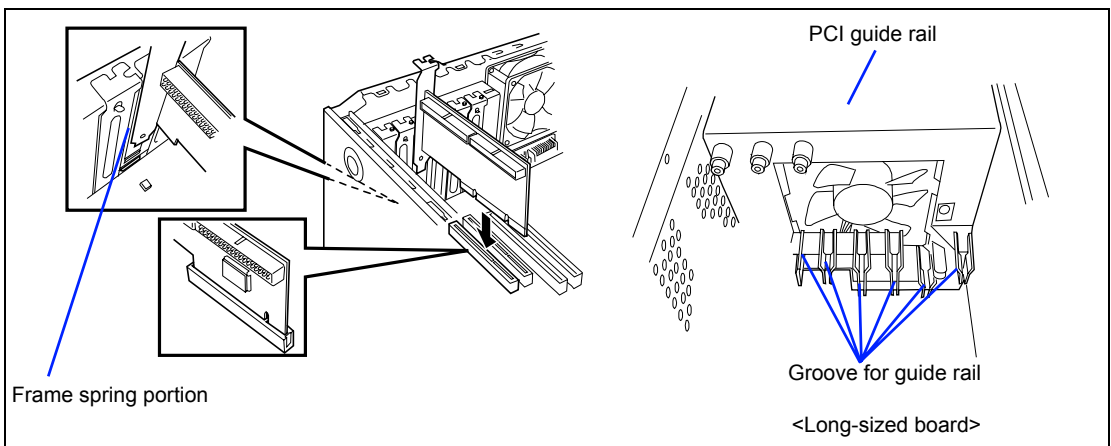

8. Install the PCI retention springs removed in step 5.

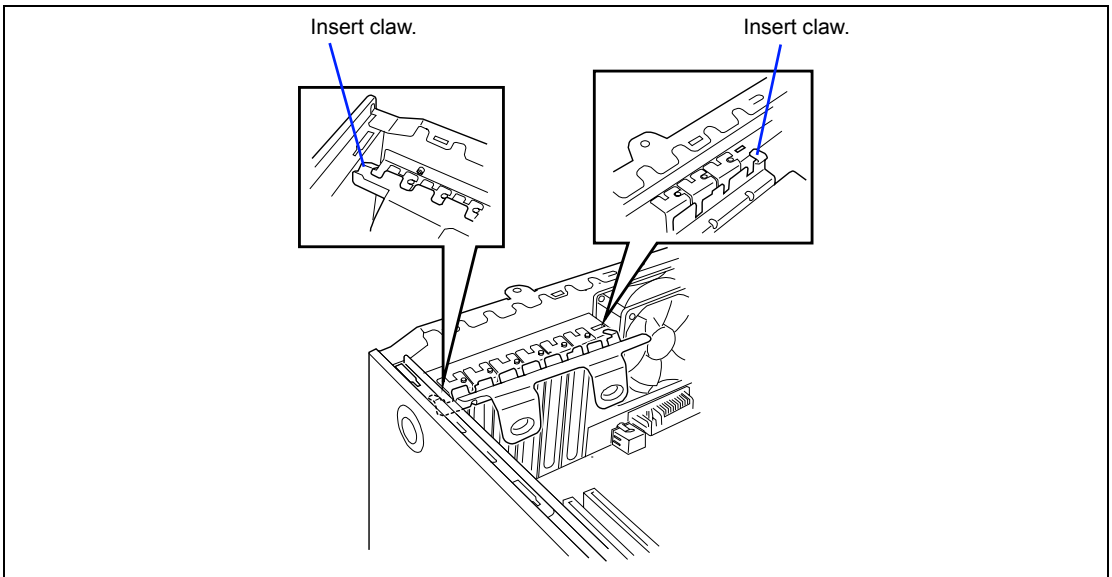

9. Push the tabs of the PCI board retention springs one by one to make them contact with the rear of the server.

A click occurs to lock each of the tabs.

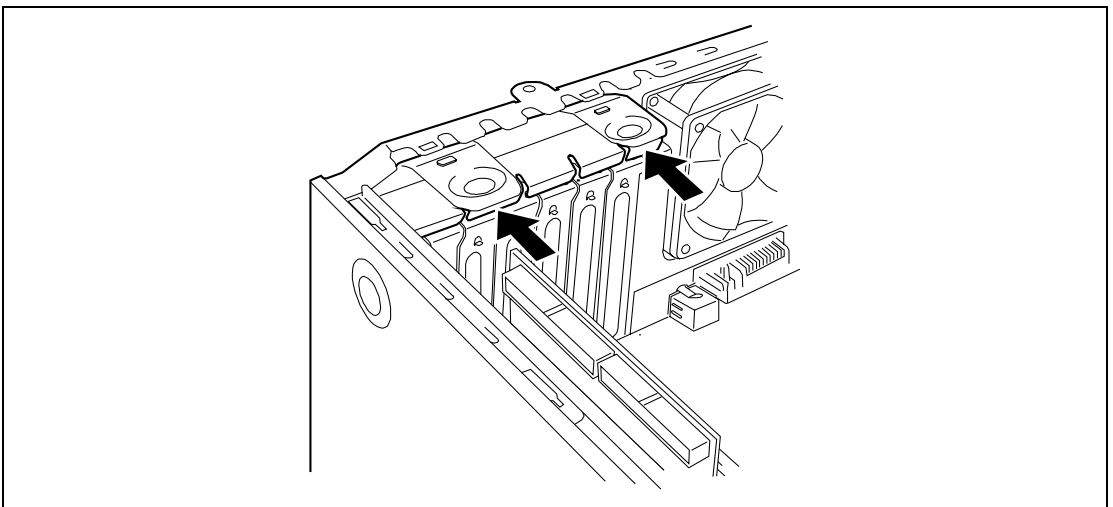

10. Assemble the server.
11. Turn on the power of the server. Make sure that no error message appears in the POST.  
If an error message appears, write down the message and contact your maintenance service representative for the maintenance.

## Setting after installation

Depending on the type of the installed board, some settings of the server must be modified by using the proper utility (such as the BIOS Setup Utility or the setup utility installed in the board) after the installation.

Provide the settings correctly according to the information described in the manual provided with the board.

The server scans the PCI bus numbers in the ascending order after the power-on. If the BIOS utility is stored in the optional ROM mounted on the board, the PCI bus start messages (banners) appear in the ascending order of the PCI bus numbers.

## Removal

Remove the board connected to the PCI board slot in the following procedure.

1. See the section "Preparing for Installation and Removal" described earlier to prepare.
2. Remove the left side cover.
3. Remove the PCI board retention springs following the installation steps 4 and 5.
4. Remove the board.
5. Install the additional slot cover and then install the PCI board retention springs following the installation steps 8 and 9.
6. Assemble the server.
7. Turn on the power of the server. Make sure that no error message appears in the POST.  
If an error message appears, write down the message and contact your service representative for the maintenance.
8. Run the BIOS Setup Utility to set the "Reset Configuration Data" in the "Advanced" menu to "Yes."

This is required to update the hardware configuration information. See Chapter 4 for details.

## Installation of N8117-01A RS-232C Connector Kit

Install the board to be connected to the PCI board slot depending on the following procedure. Refer to the manual provided with the connector kit.

1. Remove the screw from the slot to install the connector kit. Then, remove the slot cover.

---

**IMPORTANT:** Save the removed slot cover carefully.

---

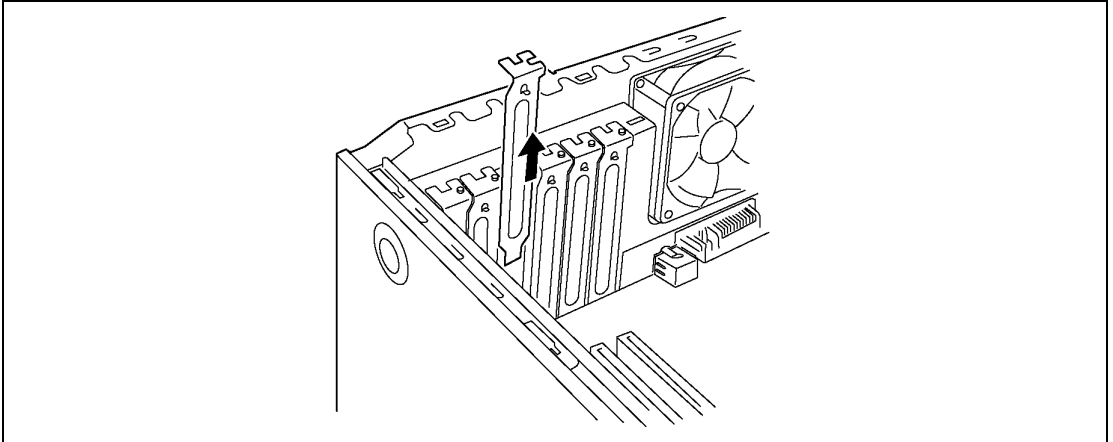

2. Install the bracket securely by making sure that the end of the bracket is inserted into the frame guide of the server.

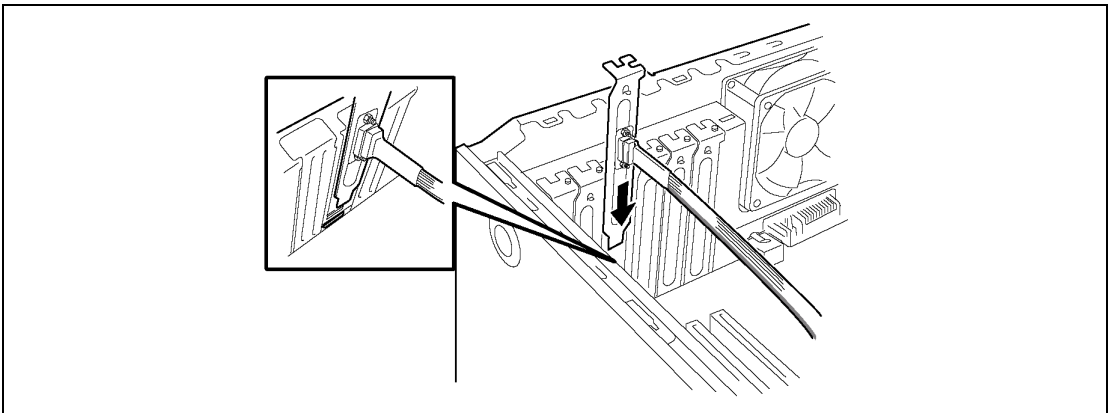

---

**IMPORTANT:** Replacement of the PCI bracket may be required depending on the server you are going to install the connector kit. The PCI bracket of low-profile type is factory installed. If you are going to install the connector kit in the full-height PCI slot, you need to replace the bracket.

---

3. Route the cable so that it does not interfere with the other PCI board, and connect the cable to the internal COM connector on mother board.

---

**NOTE:** Two types of connectors are provided with N8117-01A RS-232C Connector Kit. Use "RS232C cable (A)" for the server.

---

See the figure below for connector location.

---

**IMPORTANT:** Connect the cable properly by making sure the polarity of connector.

---

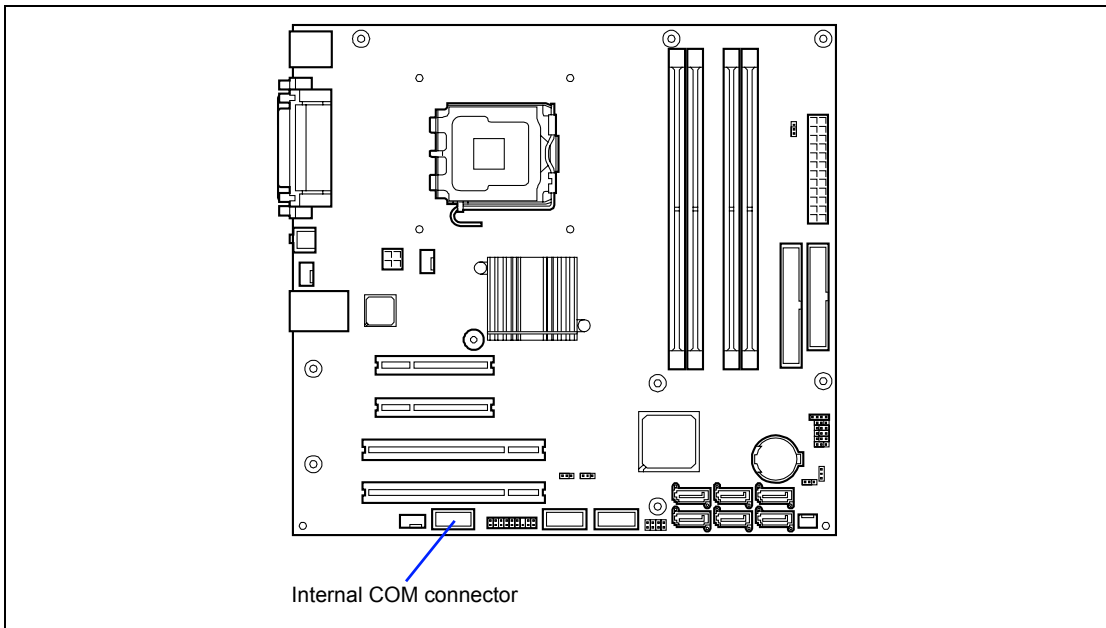

4. Make sure that the removed slot cover, screw, or tools are not left in the server. Then, reassemble the server.

---

## DIMM

The DIMM (Dual Inline Memory Module) is installed in a DIMM socket on the mother board installed in the server.

The mother board contains four sockets in which DIMMs are installed. A 256MB DIMM is factory installed in DIMM #1. (The DIMMs factory installed may be replaced.)

Up to 8GB (2GB × 4) of memory can be added.

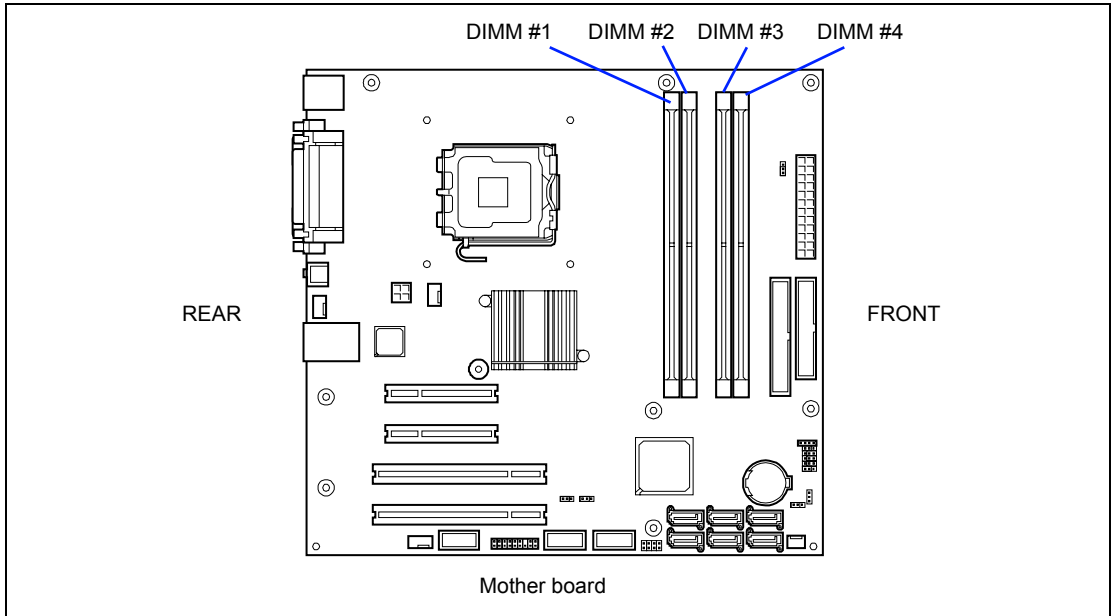

---

### IMPORTANT:

- The DIMM is easily affected by static electricity. Make sure to wear the wrist strap (an arm belt or anti-static glove), and discharge static electricity from your body before handling the DIMM. Do not make bare hands contact with terminals and components on the DIMM. In addition, do not put the DIMM on a non-anti-static desk directly. See "Static Precautions" for details of the static electricity.
  - Do not use any DIMM not approved by NEC. If an unapproved third party's DIMM is installed in the server, not only the DIMM but also the server itself may be defected. You will be charged by any repair of a malfunction or defect caused by such a device within the warranty period.
- 

The mother board in your server supports the single channel memory configuration and dual channel memory configuration.

The dual channel memory configuration provides increased performance over the single channel memory configuration.

## Maximum Memory Capacity

The available memory capacity depends on the basic architecture of the server (x86 architecture) and specifications of supported operating systems.

- Memory hole
  - The x86 architecture (IA-32) adopts Memory Mapped I/O method which reserves the fixed memory area (memory hole) for controlling various I/O devices (e.g., onboard device and PCI devices).
  - The memory hole reserves 4GB or less physical memory area as reserved memory area, regardless of mounted memory capacity. The OS cannot access this reserved area, thus, the available memory capacity may be less than the actual mounted memory capacity due to the memory hole.
- Memory Reclaim feature
  - The server provides Memory Reclaim feature for complementation of memory hole.
  - The Memory Reclaim feature remaps physical memory addresses in the memory hole on hardware (chipset). By remapping, the whole capacity of mounted memory can be used.
  - Note, however, the remap memory area may not be available depending on the memory capacity supported by OS. Accordingly, the available memory capacity depends on the supported OS.

**Memory hole  
(with physical 4GB memory installed)**

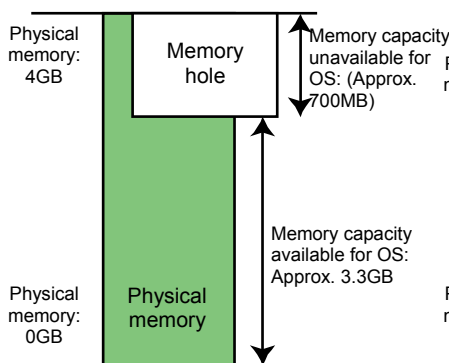

**Memory Reclaim feature  
(with physical 4GB memory installed)**

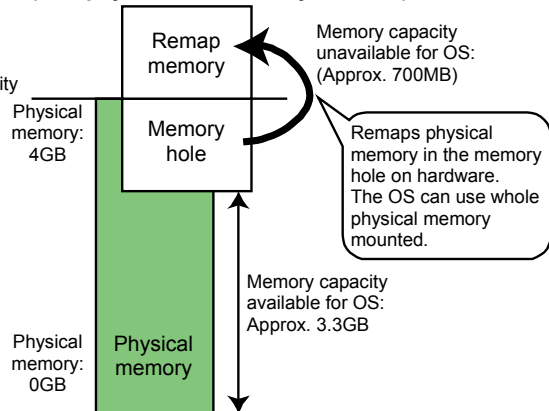

Note: When the OS support memory can support the total capacity of physical memory and memory hole.

■ Maximum memory capacity by supported OS

Supported OS	Maximum memory capacity supported by OS	Maximum memory capacity supported by the server
Microsoft Windows Small Business Server 2003 R2 Microsoft Windows Server 2003, Standard Edition(SP1) Microsoft Windows Server 2003 R2, Standard Edition	4GB	When using HW-DEP feature (factory default): 4GB When not using HW-DEP feature: Appsox. 3.3GB Note: If HW-DEP feature is not used, change [Execute Disable Bit (XD Bit)] to "Disabled" on BIOS SETUP. The factory-setting of this parameter is "Enabled".
Microsoft Windows Server 2003 R2, Standard x64 Edition	32GB	8GB

## Installation Order and Notes

- Single channel memory configuration

Install DIMMs one by one in the ascending order of DIMM slot numbers.

- Dual channel memory configuration

To activate the dual channel mode, the following conditions must be met:

- Matched DIMM configuration in each channel
- Same density\*
- Same DRAM technology\*
- Same DRAM bus width\*
- All either single-sided or dual-sided
- Matched in both channels.
- Populate symmetrical memory slots (#1 and #3, #2 and #4).

The following table lists an example of the relationship between the installation condition and the dual channel memory mode.

Installation example	Dual channel memory mode	Slot #1	Slot #2	Slot #3	Slot #4
1	Active	512MB (factory-installed)	None	512MB	None
2	Active	512MB (factory-installed)	1GB	512MB	1GB
3	Inactive	512MB (factory-installed)	1GB	512MB	None
4	Inactive	512MB (factory-installed)	1GB	None	1GB

## Installation

Install a DIMM in the following procedure.

1. See the section "Preparing for Installation and Removal" described earlier to prepare.
2. Remove the left side cover as described earlier in this chapter.
3. Firmly hold the server with your both hands so that its left side faces upward, and bring it down slowly and gently.
4. Open the levers at both ends of the socket.
5. Push the DIMM to the socket straight.

If the DIMM is inserted into the DIMM socket, the lever is automatically closed.

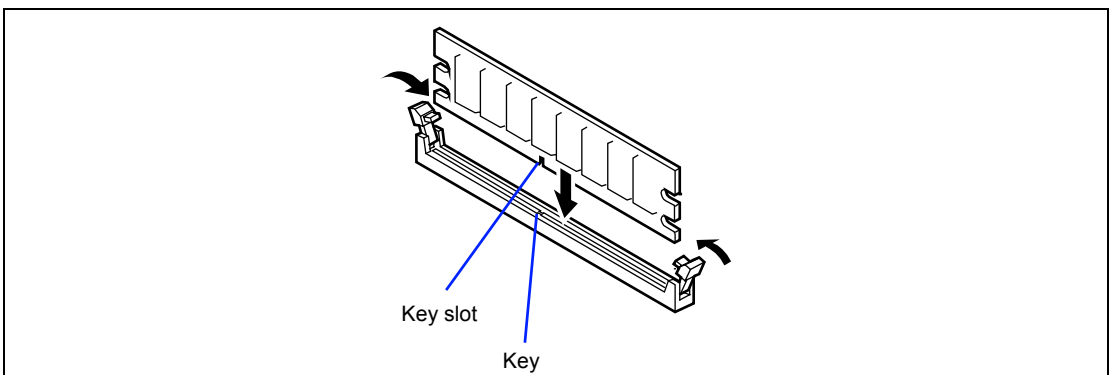

---

**IMPORTANT:** To avoid damaging the lever, do not apply an excess force to the lever.

---

---

**NOTE:** Use extreme care when installing a DIMM. Applying too much pressure can damage the socket. Keyed DIMMs insert only one way.

---

6. Close the lever securely.
7. Install the remove components.
8. Turn on the power of the server. Make sure that no error message appears in the POST. If an error message appears, write down the message and contact your service representative for the maintenance.
9. Run BIOS SETUP utility and check to see that the installed DIMMs are correctly recognized. See Chapter 4 for details.
10. Run BIOS SETUP Utility to set the "Reset Configuration Data" in the "Advanced" menu to "Yes."  
This is required to update the hardware configuration information. See Chapter 4 for details.
11. Set the paging file size to the recommended value or larger. See Chapter 5 for details.

## Removal

Remove the DIMM depending on the following procedure.

---

### NOTES:

- To remove the defected DIMM, check the error message appearing in POST or NEC ESM PRO to identify the DIMM socket (group) in which the defected DIMM is installed.
  - The server needs at least one DIMM installed to operate.
- 

1. See the section "Preparing for Installation and Removal" described earlier to prepare.
2. Open the levers at the both ends of the socket for the DIMM to be removed.

The lock is released to allow the DIMM to be removed.

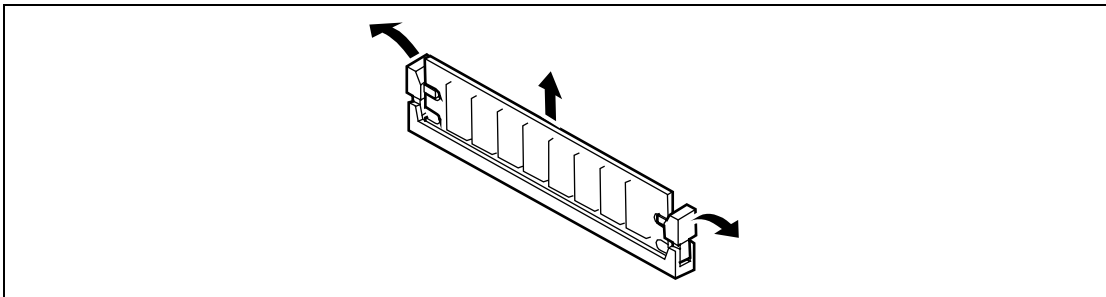

3. Remove the DIMM.
4. Assemble the server.
5. Turn on the power of the server. Make sure that no error message appears in the POST. If POST displays an error message, take a note on the message and see the POST error messages listed in Chapter 8.
6. Select "Yes" for [Reset Configuration Data] on the [Advanced] menu.  
This is required to update the hardware configuration information. See Chapter 4 for details.
7. Run the BIOS SETUP and select [Advanced] → [Memory Configuration] → [Memory Retest] → [Enabled] to clear the error information of the removed DIMM. (See Chapter 4 for details.)
8. If Windows Server 2003 is in use, set the paging file size to the recommended value or a greater value. See Chapter 5 for details.

---

## File Device

The server has two slots on which backup devices including DVD-RAM, MO, and magnetic tape drives are installed (the factory installed optical disk drive occupies another slot).

---

### NOTES:

- If a SCSI device is installed, the optional SCSI controller board and internal SCSI cable are required. See Chapter 10 for details.
  - To install the IDE device, set the operation mode as follows. Refer to the manuals provided with the optional IDE device for details.
    - Factory-installed optical disk drive: master (factory default)
    - Optional IDE device: slave
- 

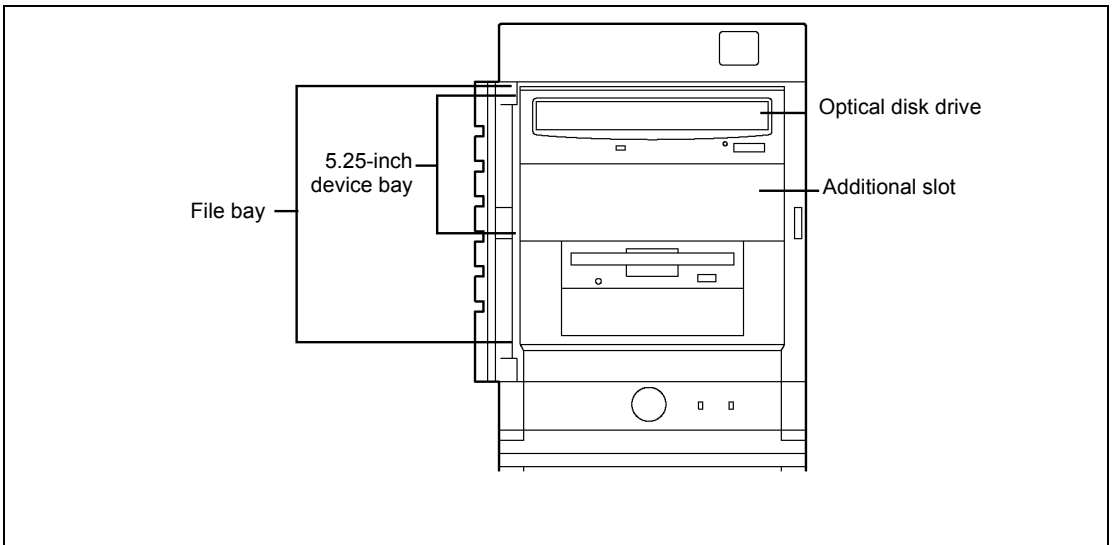

## Installation

Install a file device in the following procedure. This section describes how to install an optional SCSI device, for an example:

1. Provide the proper setting for the device.

See the table below for the settings of the devices which can be installed in the device bay.

Device	5.25-inch device
SCSI device	Termination resistance OFF*

\* If the terminator is not attached to the optional internal SCSI cable, set the termination resistance to ON.

2. See the section "Preparing for Installation and Removal" described earlier to prepare.
3. Remove the left side cover and front mask as described earlier in this chapter.
4. Remove all the cables from the factory-installed optical disk drive and the devices installed in the device bay.
5. Remove the screws securing the hard disk drive bay.

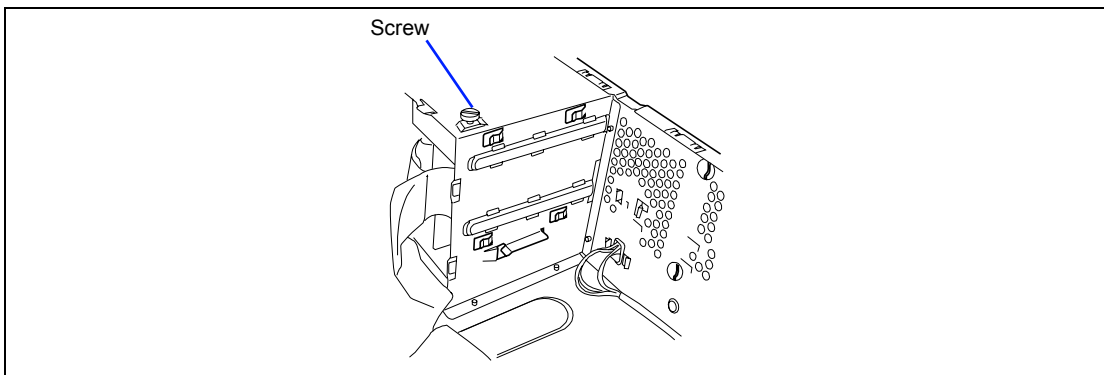

6. Pull out the file bay from the server with the release tabs on the both sides of the file bay pushed.

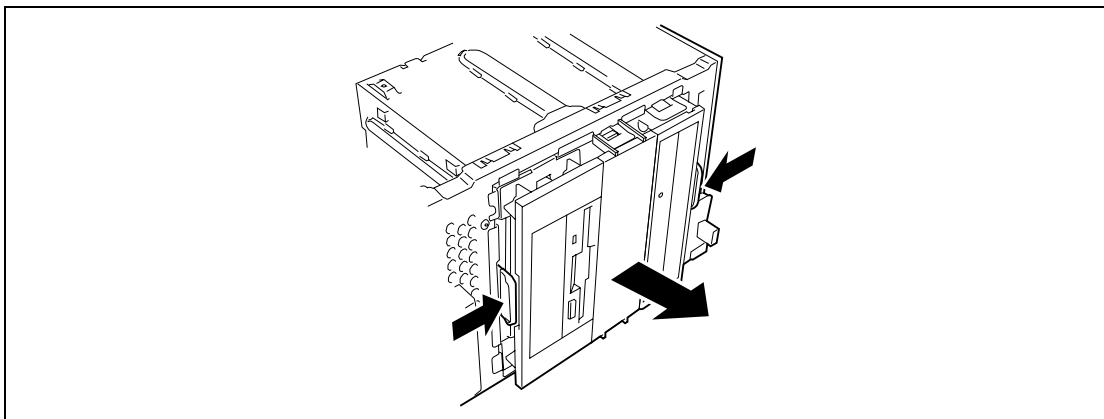

7. Place the file bay on the anti-static table carefully.
8. Slowly open the tabs on both sides of the dummy cover to remove the cover.

---

**IMPORTANT:** Save the removed dummy cover carefully.

---

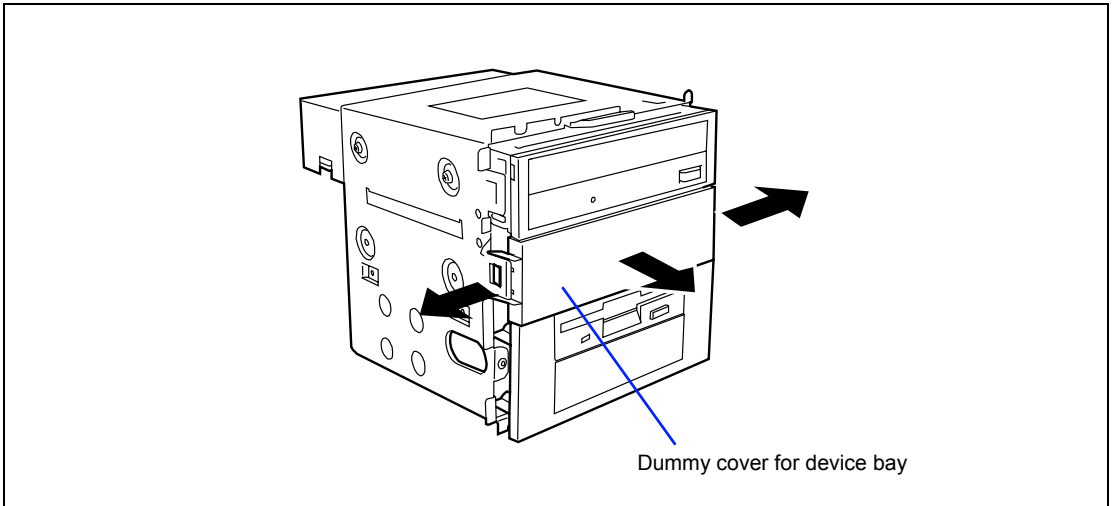

9. Remove the EMI cover.

---

**IMPORTANT:** Save the removed EMI cover carefully.

---

10. Insert a file device into the file bay.

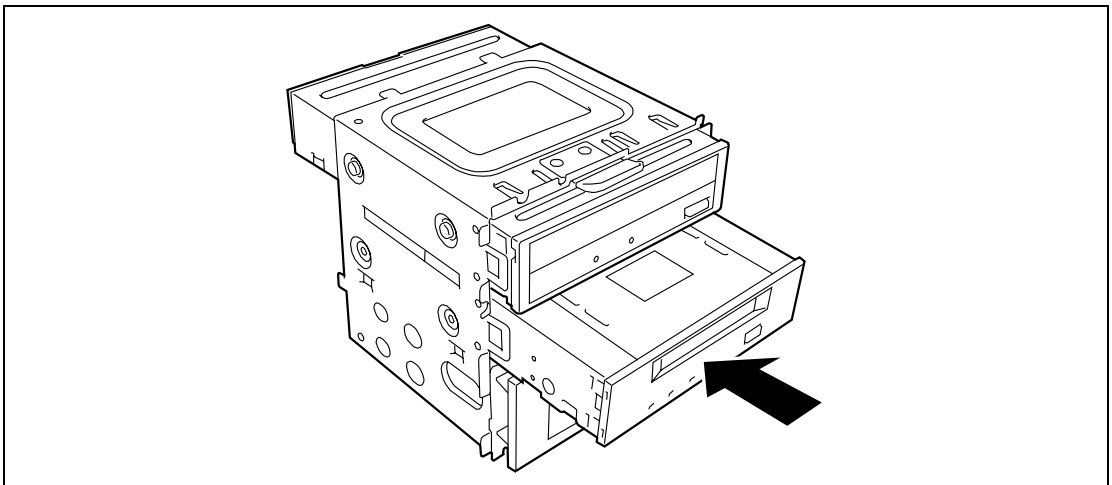

11. Align the screw holes on the device with those on the file bay and secure the device by using the four screws provided with the device.

---

**IMPORTANT:**

- Use the screws provided with the optional device to secure it. If not, use the screws provided with the server. Using screws longer than the required length may cause the device to be damaged.
- Align the front face of the device to be installed with the front face of the factory-installed optical disk drive.

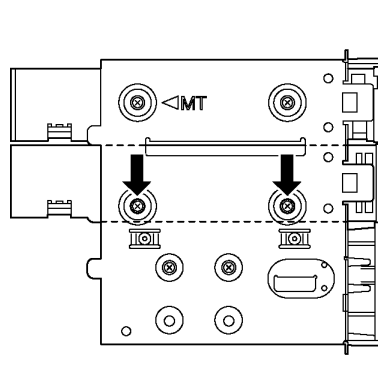

- When installing a device that has a protrusion on its front face such as a cover, it may interfere with the front bezel. In such case, install a device rearward so that it would not interfere with the front bezel.

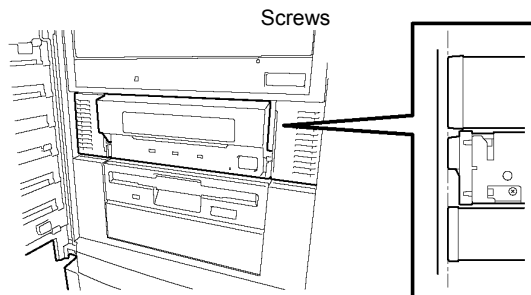

12. Insert the file bay into the server.  
Push the file bay until a click occurs to lock it.

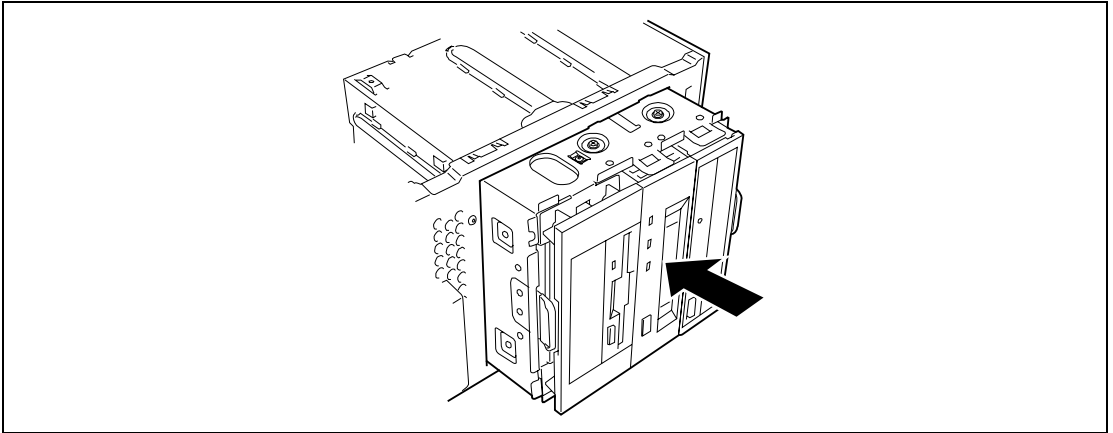

13. Connect the interface and power cables to the 5.25-inch device.  
See Chapter 10 for details.

**NOTE:** Connect the interface cable of the floppy disk drive so that the end with the red line indicating pin 1 faces the mother board.

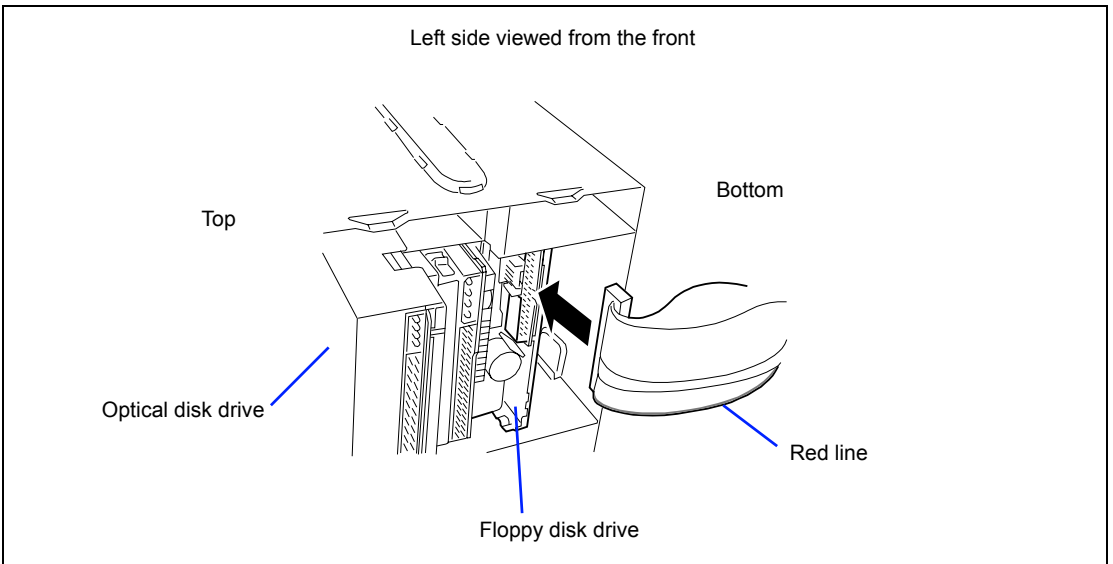

- 14.** Assemble the server.
- 15.** If a SCSI device is installed, set the parameters including the transmission rate using the BIOS utility of the SCSI controller.  
Refer to the manual provided with the SCSI controller for details.
- 16.** Install the device driver for the installed device, if needed.  
Refer to the manual provided with the device for details.

## **Removal**

The file device can be removed in the reverse order of the installation. If the device is removed but not installed again, install the EMI and dummy covers.

---

## Floppy Disk Drive

Your server can contain an optional floppy disk drive.

### Installation

1. See the section "Preparing for Installation and Removal" described earlier to prepare.
2. Remove the left side cover and front mask as described earlier in this chapter.
3. Remove all the cables from the factory installed optical disk drive and the devices installed in the device bay.
4. Remove the screws securing the hard disk drive bay.

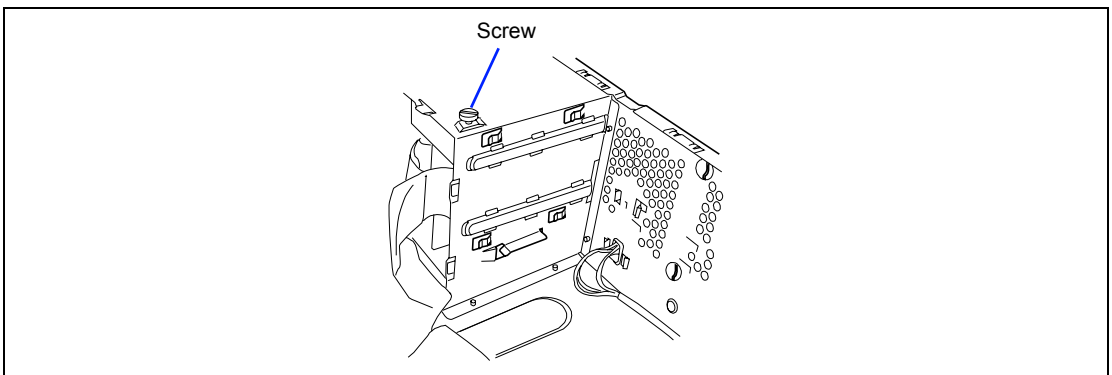

5. Pull out the file bay from the server with the release tabs on the both sides of the file bay pushed.

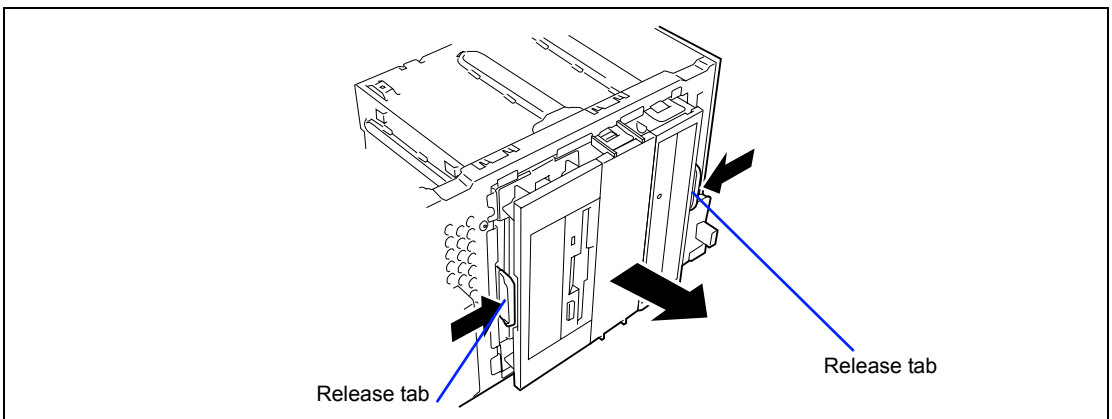

6. Place the file bay on the anti-static table carefully..
7. Slowly open the tabs on the both sides of the bracket cover to remove the cover.

**IMPORTANT:** Save the removed bracket cover carefully.

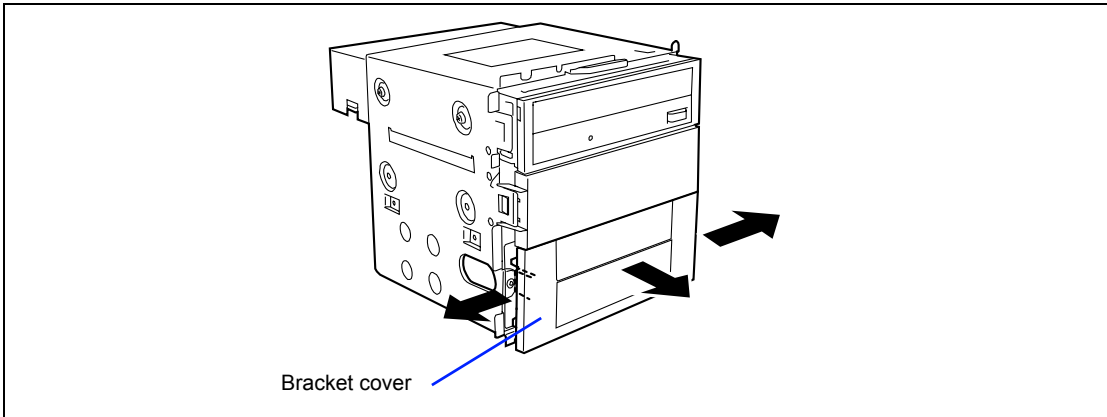

8. Insert a floppy disk drive into the file bay.

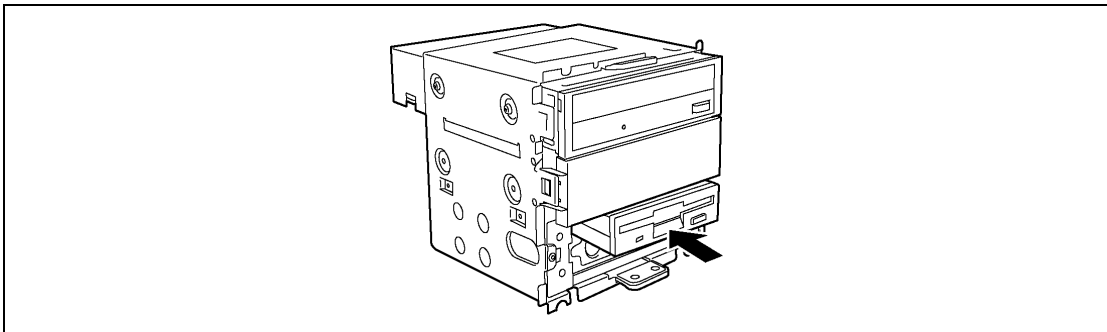

9. Fix the floppy disk drive with three screws (two for left side, and one for right side).

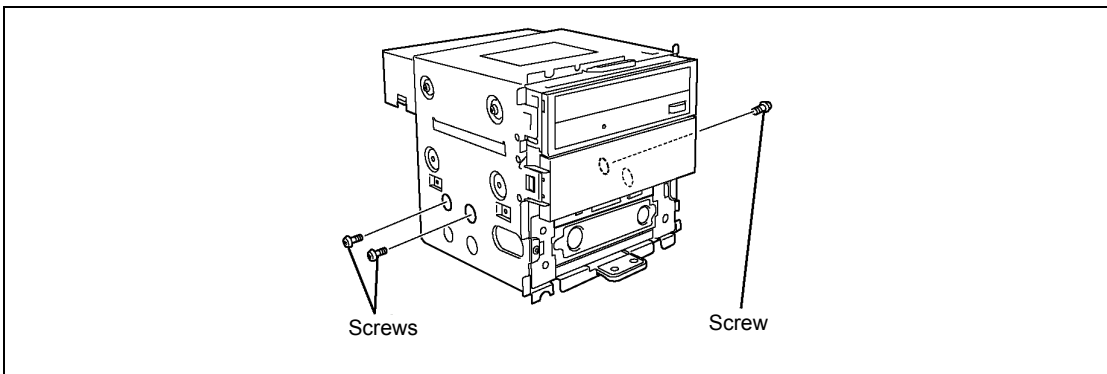

10. While extending the both hooks on inner side of the bracket, remove the bracket from the bracket cover.

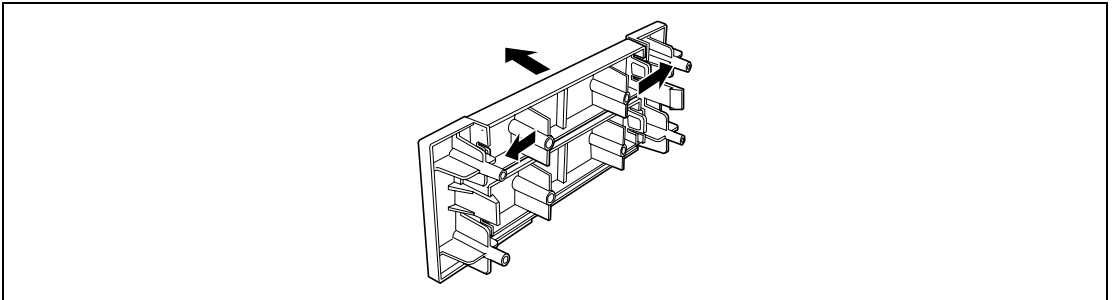

11. Install the bracket cover.

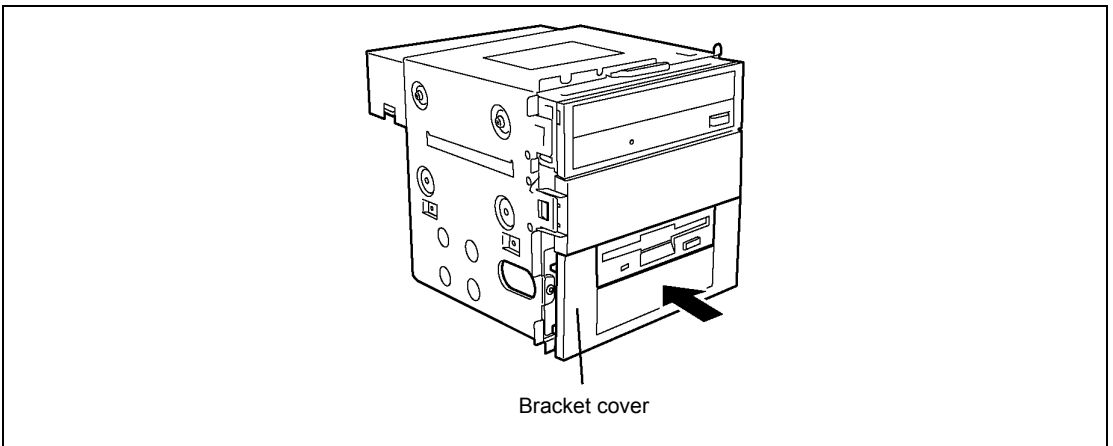

12. Change setting for floppy disk drive on BIOS Setup menu.
  - 1) Select [Main] → [Legacy Diskette A:], and select [1.44/1.25 MB 31/2"]. Then select [Exit] → [Exit Saving Changes], and restart the server.
  - 2) Run BIOS Setup menu and select the [Boot] menu. Put the cursor onto "Legacy Floppy Drives" under "Excluded from boot order", and press x to move it to "Boot priority order". Then, press + to move the item to the desired priority order. In normal case, set the priority of floppy disk drive next to CD-ROM drive.

## Removal

The floppy disk drive can be removed in the reverse order of the installation.

(This page is intentionally left blank.)

# Chapter 10

---

## Internal Cabling Diagrams

Internal cable connections of the server are shown below.

---

**NOTE:** See Chapter 2 for detail connector locations on the mother board.

---

## INTERFACE CABLES

This section describes the connections of the interface cables.

### Addition of Hard Disk Drive

The connection required when a hard disk drive is added is described below.

### Installation of SATA Disks

If the serial ATA (SATA) hard disk drives are added, connect the cables as shown in the figure below. Fill the drive bay with the hard disk drives from the top to bottom bay.

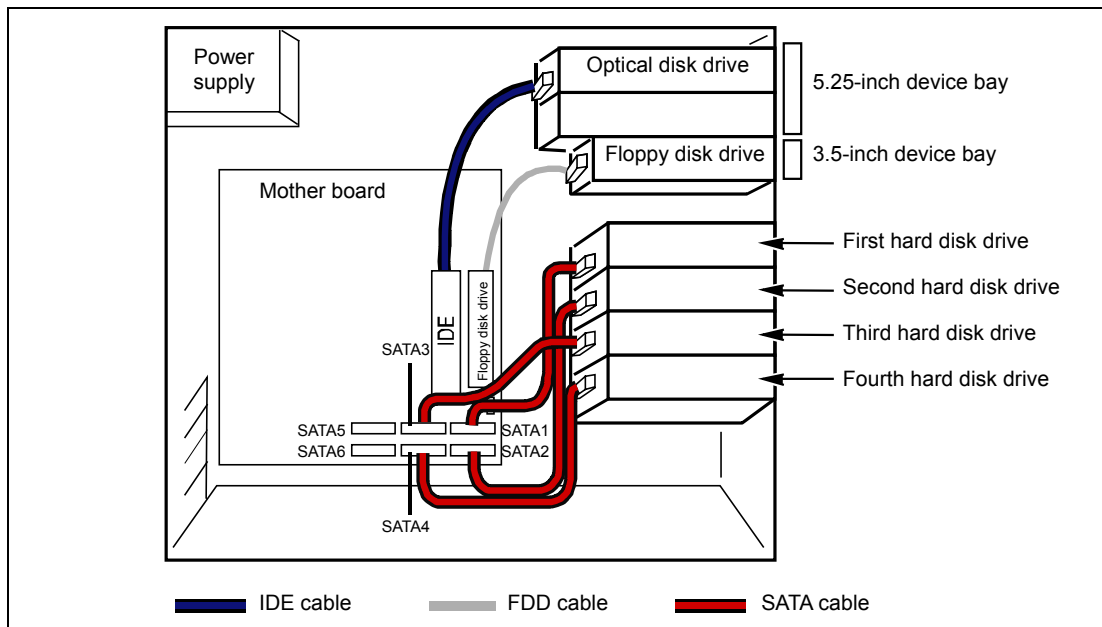

If two or more SATA hard disk drives are connected, you can configure a RAID System by using the onboard RAID Controller. See Chapter 4 for details.

### With Optional RAID Controller Installed

If the optional RAID controller is additionally installed, you need the dedicated cable (K410-155) for connection. Fill the drive bay with the hard disk drives from the top to bottom bay.

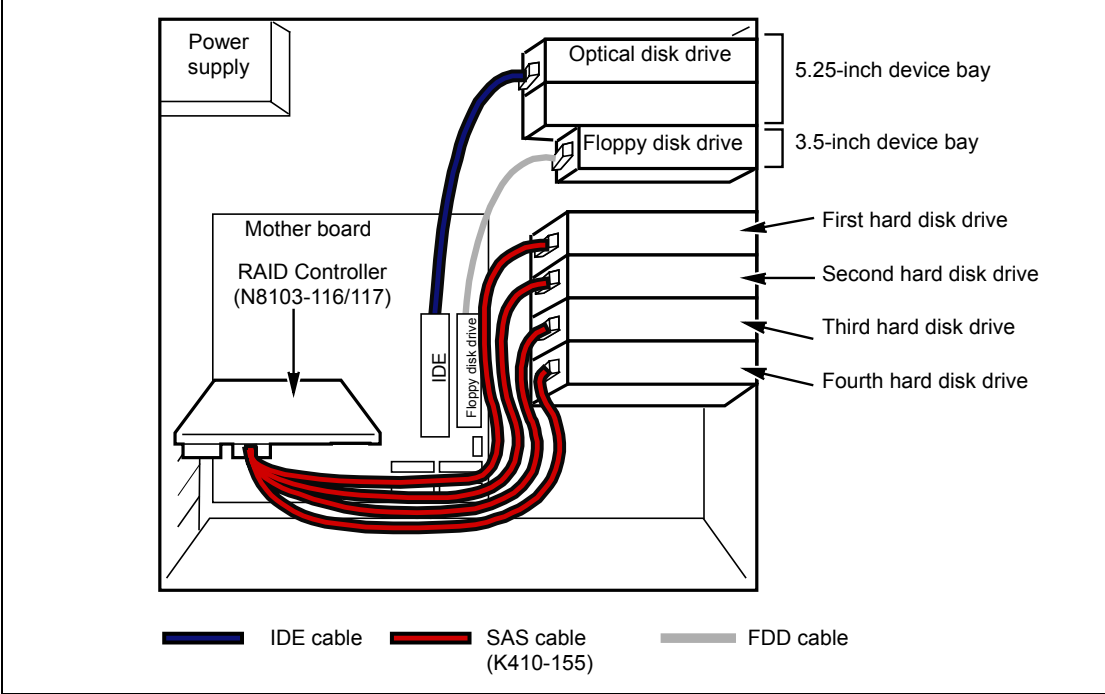

### With SAS Hard Disk Drives Installed

When SAS hard disk drives are installed, connect the cable as shown in the figure below.

Fill the drive bay with the hard disk drives from the top to bottom bay.

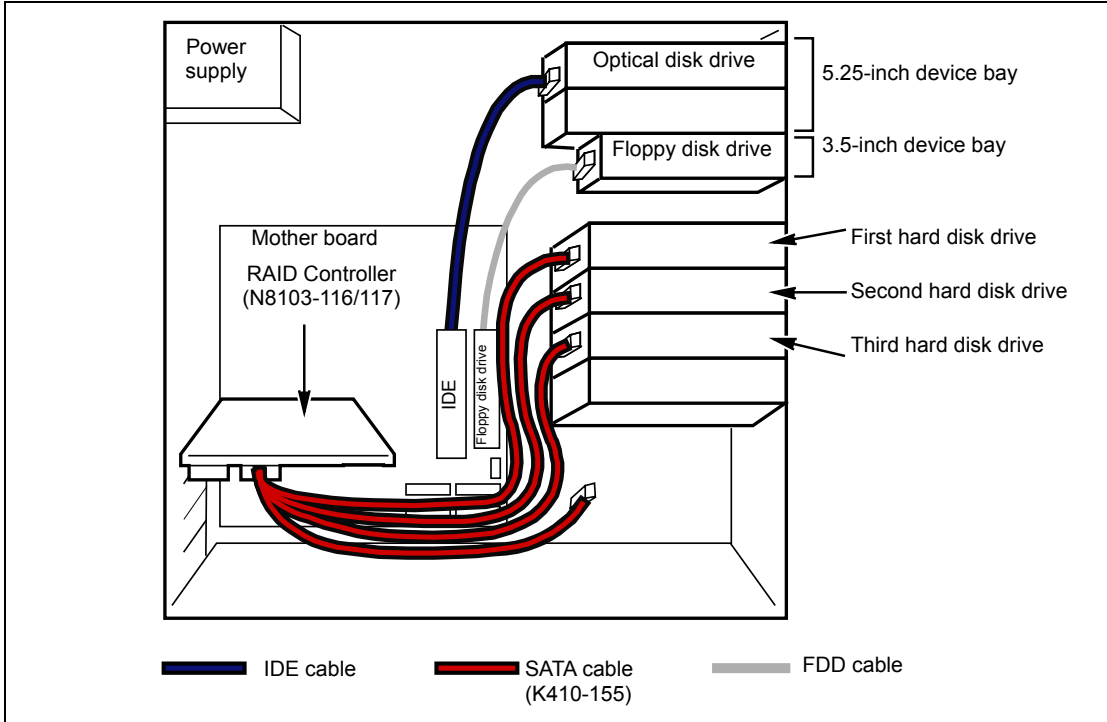

---

**IMPORTANT:**

- To connect the SAS hard disk drives, you need a cable dedicated to optional RAID controller.
- Up to three SAS hard disk drives can be installed.
- The SAS hard disk drive cannot be installed together with SATA hard disk drive.
- RAID LED cable  
To let the DISK Access lamp on the front panel indicate the access states of the hard disk drives connected to the RAID controller, connect the LED cable provided with the server to the LED connector on the motherboard and the optional RAID controller.

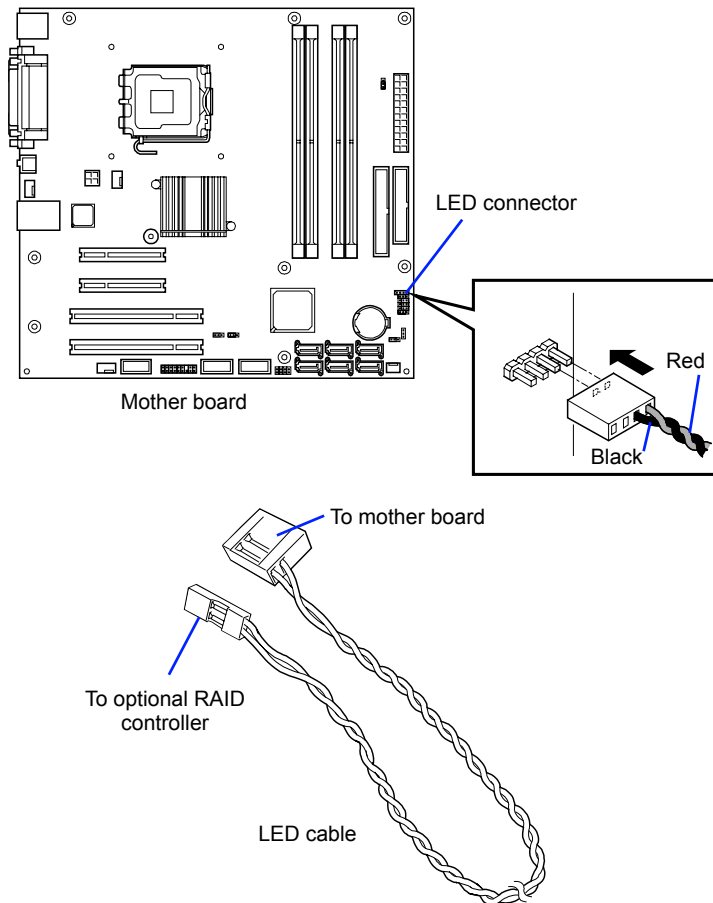

## Connection of 5.25-inch Device

The 5.25-inch device bay can be equipped with a SCSI device, an IDE device, or a USB device (using internal connector).

### Installation of SCSI Device

The SCSI controller and the SCSI cable used for the connection is sold separately. If the SCSI cable sold separately has the connector for terminating the SCSI connection, make the termination setting of the 5.25-inch device invalid.

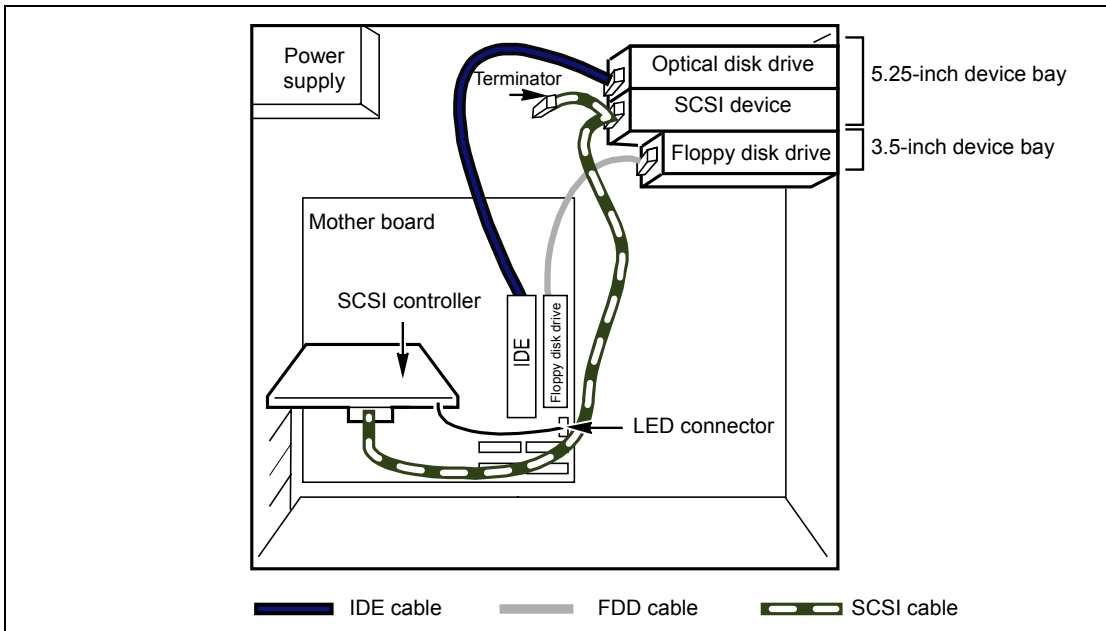

### Installation of IDE Device

Use the IDE cable that comes with the server.

Set master/slave for the IDE device so that it does not conflict with any other IDE devices.

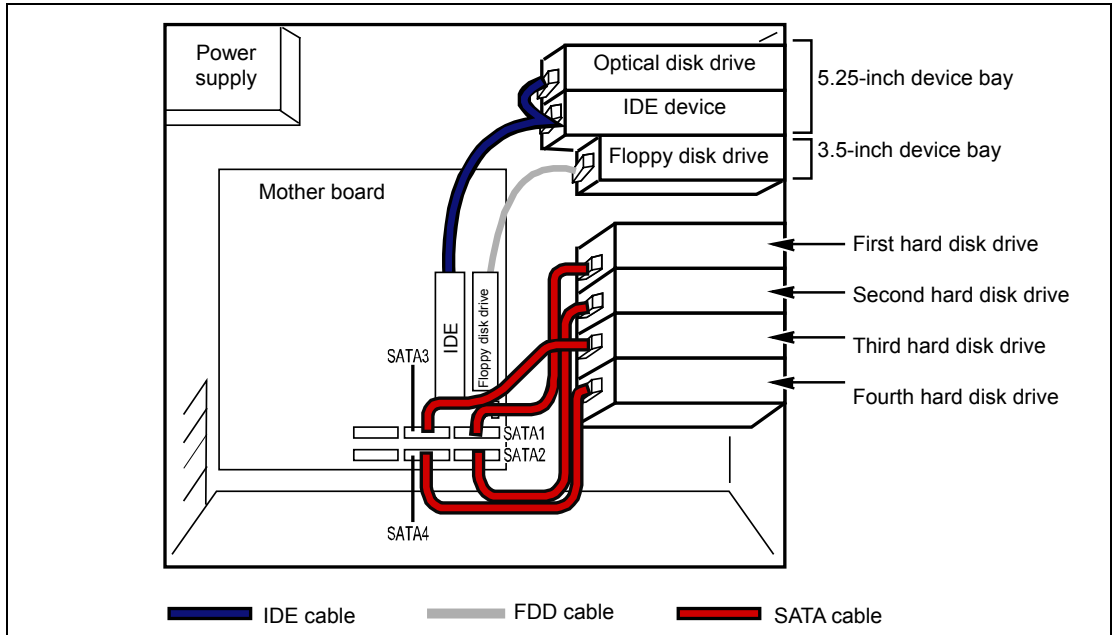

### Installation of USB Device (Internal Connector)

Use the USB cable that comes with the device.

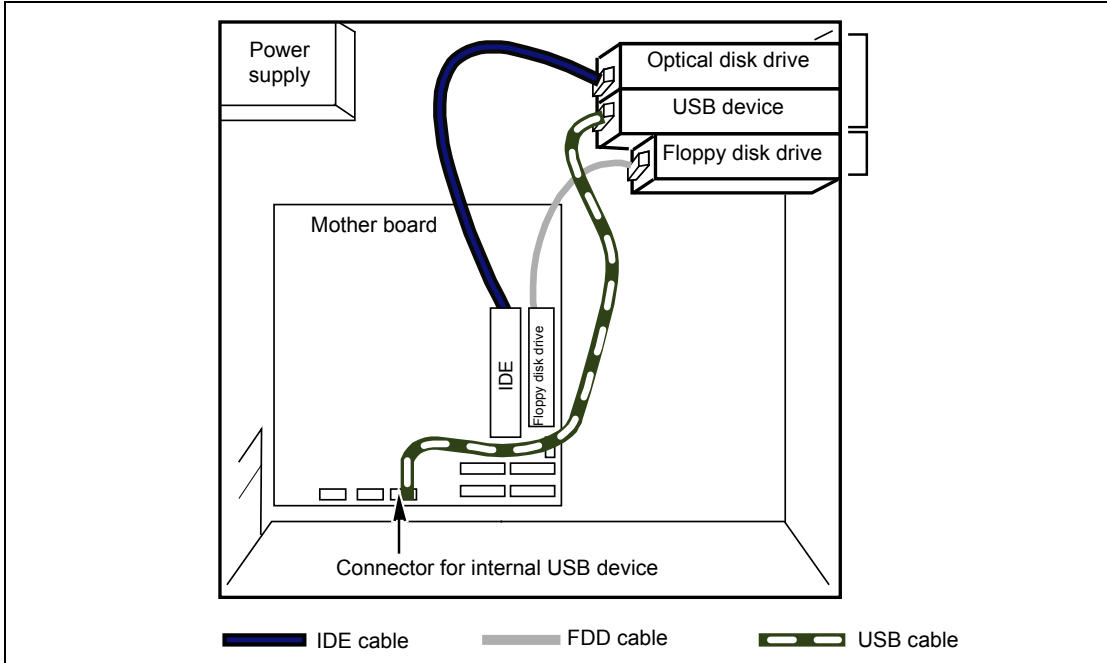

# POWER CABLES

An example of the power cable connection is shown in the figure below. The server only uses the power cables shown here.

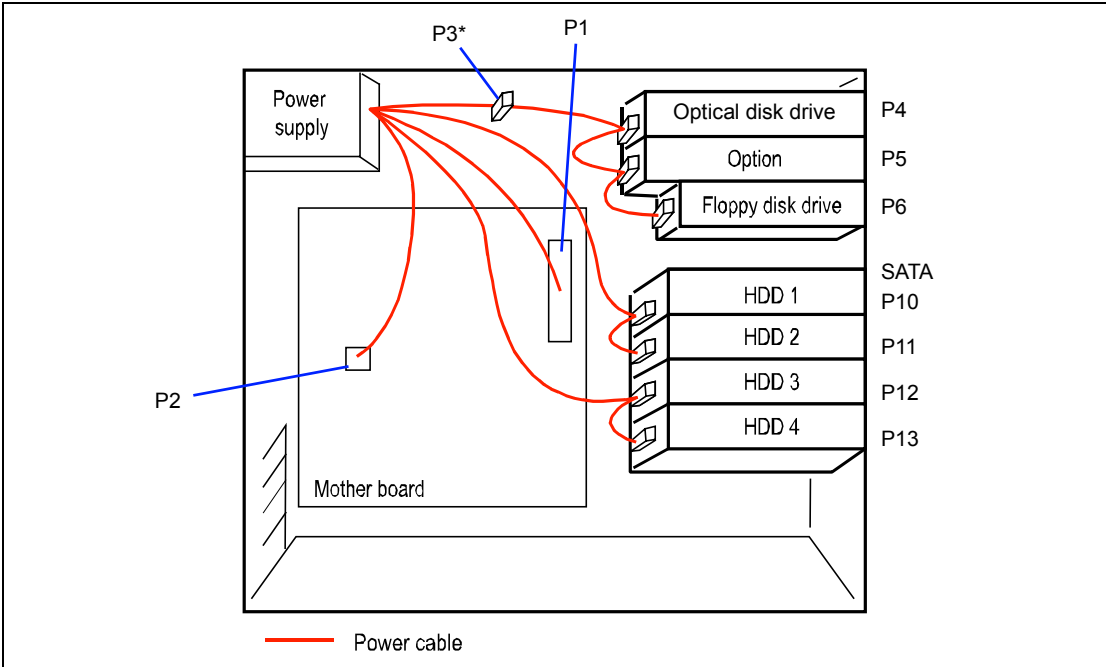

(This page is intentionally left blank.)

# Appendix A

## Specifications

Item		NEC Express5800/110Ge		
		N8100-1447F	N8100-1448F	N8100-1449F
CPU	Type	Intel® Celeron® processor	Intel® Pentium® Dual Core processor	DualCore Intel® Xeon® processor
	Clock / Cache	1.80GHz/512KB	1.80GHz/1MB	2.33GHz/4MB
	Number of processors	1		
	Maximum	1		
Chipset		Intel® 3200 + 82801IR (ICH9R)		
Memory	Standard	512 MB (512 MB × 1)		
	Maximum	8 GB (2 GB × 4, the standard DIMM must be replaced.)		
	Expansion unit	1 DIMM (DDR2-800 SDRAM DIMM, unbuffered)		
	Expansion times	3 times		
	Memory module	SDRAM DIMM (DDR2-800, Dual channel memory configuration supported)		
Error check		ECC		
Graphics (VRAM)		XGI Z9s + 32MB VRAM		
Auxiliary input device	Floppy disk (option)	3.5-inch drive × 1		
	Hard disk drive (standard)	None		
	Hard disk drive (maximum)	SATA2: 750GB × 4		
	DVD-ROM (standard)	DVD: x6 or faster (x16 max.), CD: x20 or faster (x40 max.)		
5.25-inch file bay		2 slots (An optical disk drive is factory-installed.)		
3.5-inch disk bay		1 slot		
Additional PCI slot		4 slots (1 slot for PCI-Express (x8), 1 slot for PCI-Express (x4, connector: x8), 2 slots for 32bit/33MHz)		
Disk array	Standard	SATA *LSI Embedded MegaRAID (RAID0, 1, 10)		
	Option	RAID controller		
External interface	Keyboard	MINI DIN 6-pin connector (1 port)		
	Mouse	MINI DIN 6-pin connector (1 port)		
	USB	4-pin (Front: 2 ports, Rear: 2 ports, Internal: 2 ports), USB2.0 supported		
	Serial	D-sub 9-pin (1 port)		
	Parallel	IEEE1284 standard, D-sub 25-pin (1 port)		
	Network	RJ-45 (1 port, 1000BASE-T/100BASE-TX/10BASE-T)		
Display		MINI D-sub 15-pin (1 port)		
Cabinet design		Desk-side, mini tower		
External dimensions		173 (width) × 448 (height) × 453 (depth) mm		
Weight		18 kg (Max.)		
Power supply		100 to 120 VAC ±10%, 200 to 240 VAC ±10%, 50/60 Hz ±1 Hz		
Power consumption		248 VA, 245 W	248 VA, 245 W	248 VA, 245 W
Environmental requirements	Temperature	10 to 35°C (operating), -10 to 55°C (non-operating, storage)		
	Humidity	20 to 80% RH (no condensation)		

(This page is intentionally left blank.)

# Appendix B

---

## Other Precautions

---

### Transfer Rate of the On-board LAN Controller

The onboard network interface controller supports 10Base-T and 100Base-TX networks and is capable of full or half duplex.

The controller can automatically detect and switch for network speed and transfer mode connected to the HUB. However, for proper network operation, specify the link speed and duplex mode to the same value as the value specified for HUB.

---

### Server Management Software

The NEC EXPRESSBUILDER DVD that comes with the server contains the NEC ESMPRO utility.

NEC recommends that you should install the NEC ESMPRO for effective use of the reliability enhancement features of the server.

---

### Floppy Disk

The following describes use of the floppy disk.

#### Floppy disk type

The server uses 3.5-inch floppy disks. You can use the following two types of 3.5-inch floppy disks:

- 2HD floppy disk (double-sided high-density track type)  
Stores data of 1.44MB.
- 2DD floppy disk (double-sided double-density track type)  
Stores data of 720KB.

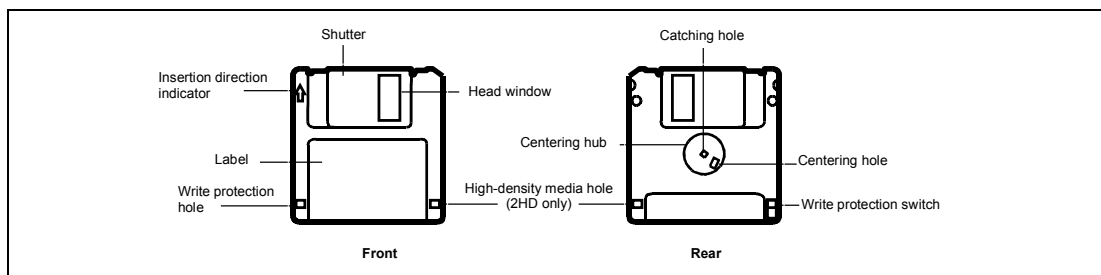

### Notes on use

The floppy disk is an important data storage media with delicate structure and requires care. Keep the following notes in mind to use it:

- Insert the floppy disk into the floppy disk drive gently as far as it goes.
- Attach the label to the correct position.
- Do not write anything directly onto the disk surface with a pencil or ball-point pen.
- Do not open the shutter.
- Do not use the floppy disk in a dusty place.
- Do not place anything on the floppy disk.
- Do not leave the floppy disk in a high-temperature place (e.g., place exposed to direct sunlight or close to a heater).
- Do not leave the floppy disk with foods and drinks, or in a place exposed to cigarette smoke.
- Do not leave the floppy disk near any form of liquid or a chemical or in a place where a chemical may be accidentally sprayed over them.
- Do not place any magnetic objects (e.g., magnet) near the floppy disk.
- Do not clip the floppy disk or drop it.
- Keep the floppy disk in a floppy disk case that protects it from magnetism and dust.

- Write-protection

A floppy disk has a write-protect switch that prevents the stored data from accidental erasure.

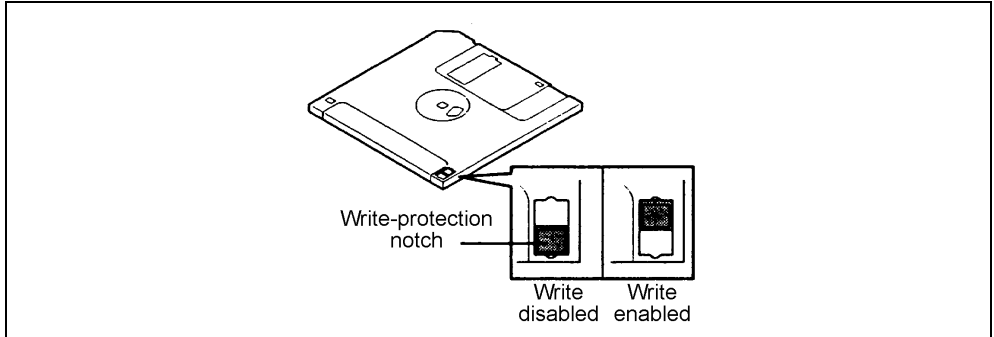

You can read data from a write-protected floppy disk, but you cannot save data into the floppy disk or format it. NEC recommends that you should write-protect any floppy disk containing valuable data unless you are about to save data.

To write-protect a 3.5-inch floppy disk, use the write-protect switch provided on its back.

- Disk format

To write data into a floppy disk, the floppy disk must be "formatted." "Formatting" is to initialize the floppy disk and make it available for the system environment (operating system).

---

**IMPORTANT:**

- Formatting a used floppy disk clears all the data contained in it, if any.
- Formatting a floppy disk from the DOS command line is not available with the server. Use a formatted floppy disk to work with it on the DOS command line.

The format method depends on your operating system. Refer to the manual that comes with your operating system for details.

- Data backup

"Data backup" is to copy data stored in a media into another media (e.g., floppy disk, digital audio tape, or magnet-optical disk).

---

**IMPORTANT:** Make sure to make a back-up copy of every floppy disk, if provided.

---

The floppy disk is a very delicate storage media. Dust or thermal changes, as well as operator's misconduct or sever failures, may cause loss of data. To avoid loss of data, NEC recommends that you should make a back-up copy of your valuable data on a regular basis.

---

## DVD/CD-ROM

Keep the following notes in mind to use the DVD/CD-ROM for the server:

- Press the center of the storage case to remove the DVD/CD-ROM from the case.
- Do not drop the DVD/CD-ROM.
- Do not place anything on the DVD/CD-ROM or bend the DVD/CD-ROM.
- Do not attach any label onto the DVD/CD-ROM.
- Do not touch the signal side (nothing is printed on this side) with your hand.
- Place the DVD/CD-ROM with its printed side upward and gently put it on the tray.
- Do not scratch the DVD/CD-ROM or write anything directly on it with a pencil or ball-point pen.
- Do not leave the DVD/CD-ROM with foods and drinks, or in a place exposed to cigarette smoke.
- Do not leave the DVD/CD-ROM in a high-temperature place (e.g., place exposed to direct sunlight or close to a heater).
- When dust or fingerprints are attached on the DVD/CD-ROM, wipe the DVD/CD-ROM from its center to edge with a dry soft cloth slowly and gently.
- Use the dedicated cleaner to clean the DVD/CD-ROM. Do not use record spray/cleaner, benzene, or thinner.
- Keep the DVD/CD-ROM in the dedicated case when not in use.

---

## Tape Media

The following describes data handling with the DAT, DLT, or AIT optionally available for the server.

- Saving your valuable data

When you save your valuable data or programs into the cartridge tape, you should save them into two cartridge tapes to make the primary and secondary tapes.

This enables you to restore your data from one tape when the other makes a read error, as well as to protect your valuable data and programs from loss.

- Three-generation data management

NEC recommends that you should employ three-generation data management for data storage.

Three-generation data management uses three cartridge tapes: A, B, and C. You save data to tape A on the first day, tape B on the second day, tape C on the third day, tape A on the fourth day, and so on. That is, you save data into cartridge tapes cyclically from tape A through C.

This enables you, for example, to use tape B to restore the data when tape C makes a read error. Also when both tapes B and C make a read error, you can restore your valuable data by using the data stored in tape A.

---

## Keyboard

The keyboard is a device to instruct your computer by entering alphanumeric characters or symbols.

---

### IMPORTANT:

- Do not pour any liquid such as water or put anything into the keyboard. Doing so may cause a failure of the keyboard.
- The keyboard provided with the server is designed for adjustment of an angle. Adjust the keyboard angle at which the keyboard is easy to operate. The adjustment assists in reducing strain on your shoulders, arms, and fingers.

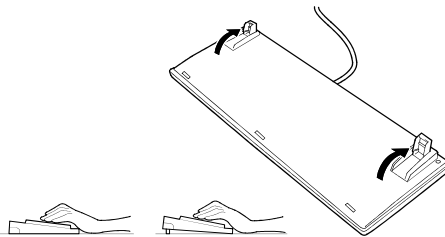

---

**NOTE:** The keyboard functions depend on the software. Refer to the manual that comes with the software for details.

---

---

## Mouse

Like the keyboard, the mouse is a device to instruct your computer. Many OS's and application software require the mouse for operation.

---

### NOTE:

- Functions assigned to the mouse buttons vary depending on the software. For details, refer to the manual provided with the software.
- Use the mouse on a clean desk. Using the mouse on a dusty or dirty desk disturbs smooth movement or normal operation of the mouse. When your mouse movement seems dull, clean your mouse. (See Chapter 7.)

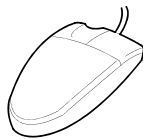

Mouse operation includes "Click," "Double-click," and "Drag."

Click: Press the button only once and release it.

Double-click: Press the button twice consecutively and release it.

Drag: Press and hold the button and move the mouse.

Operation of the server involves combinations of these mouse operations and data entries with the keyboard.

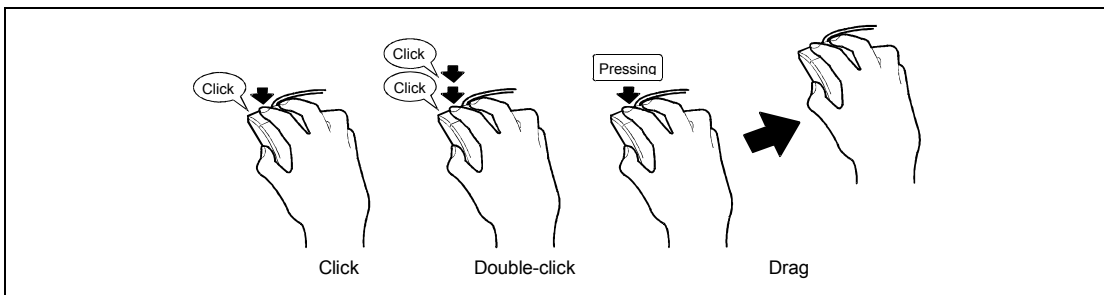

# Appendix C

---

## IRQ

The factory-set interrupt requests are listed below. Find an appropriate one to install an optional device.

<b>IRQ</b>	<b>Peripheral Device (Controller)</b>
0	System timer
1	Keyboard
2	Cascade connection
3	COM2 serial port
4	COM1 serial port
5	PCI
6	Floppy disk
7	Parallel port
8	Real-time clock
9	Microsoft ACPI Compliant System
10	PCI
11	PCI
12	Mouse
13	Numeric processor
14	Primary IDE channel
15	Secondary IDE channel

(This page is intentionally left blank.)

# Appendix D

---

## Installing Windows Server 2003 x64 Editions

This section explains how to install the Windows Server 2003 x64 Editions.

### BEFORE INSTALLING Windows Server 2003 x64 Editions

Read the following notes or information before installing the Windows Server 2003 x64 Editions.

---

#### Optional Board Supported by NEC EXPRESSBUILDER

The NEC EXPRESSBUILDER DVD attached to your server supports the following optional boards;

---

**NOTE:** If you want to install the other boards by using a driver floppy disk ("OEM-FD for Mass storage device"), except ones listed below, see "Installing with the OEM-FD for Mass storage device" and "Installing Optional Mass Storage Driver" of "Parameter File Creator" in Chapter 6.

---

- Controllers supporting installation of OS with Express Setup
    - N8103-116 RAID controller (128 MB, RAID0/1)
    - N8103-117 RAID controller (128 MB, RAID0/1/5/6)
    - LSI Embedded MegaRAID™ (embedded on the mother board)
  - Other controllers
    - N8103-75 SCSI Controller\*
    - N8103-95 SCSI Controller\*
    - N8103-107 SCSI Controller\*
- \* Option

---

## **Service Pack Which EXPRESSBUILDER Supports**

The EXPRESSBUILDER DVD attached to the server supports following combination of the OS installation media and Service Pack.

- Windows Server 2003 R2 x64 Edition
  - OS installation media (with Service Pack 2)
  - OS installation media (No Service Pack) + Service Pack 2
  - OS installation media (No Service Pack)

---

## **Installing Service Pack**

You can install the Service Pack on the server. When the Service Pack is not attached to your system, prepare it by yourself.

---

## **Updating System**

If you modified the Windows system, execute "Update the System" in Autorun Menu.

---

## **Re-installing to the Hard Disk Drive which has been upgraded to Dynamic Disk**

If you want to leave the existing partition when installing the system on the hard disk drive upgraded to Dynamic Disk, note the following issue:

- Do not select the partition that OS had been installed as the partition to install the OS newly.
- Select "Use the current File System" for the format of OS partition.

---

## **Mounting MO Device**

Do not mount an MO device on your server during the Windows installation.

---

## **About Removable Media**

Do not set removable media, such as DAT, into the device mounted on your server during the OS installation.

---

## About the System Partition Size

The system partition size can be calculated from the following formula.

Size necessary to install the system	+ Paging File Size + Dump File Size + Application Size
Size necessary to install the system	= 4100MB (Windows Server 2003 x64 Editions) = 4100MB (Windows Server 2003 R2 x64 Editions with Service Pack 2) = 5900MB (Windows Server 2003 x64 Editions + Service Pack 2 CD-ROM)
Paging File Size (Recommended)	= Mounted Memory Size * 1.5
Dump file Size	= Mounted Memory Size + 1MB
Application Size	= Required Size

---

### IMPORTANT:

- The above-mentioned paging file size is recommended for collecting debug information (memory dump). The paging file with initial size large enough to store the dump file in the boot drive is required.  
Correct debug information might not be able to be collected due to virtual memory shortage when the paging file is insufficient, so set an enough size of the paging file with the entire system.
  - Regardless of the size of the mounted memory, or the Write debugging information (type of memory dump), the maximum size of the dump file is 'The size of the mounted memory + 1MB'.
  - If you install any application program or the like, add necessary space to the partition to install these programs.
- 

For example, if the mounted memory size is 512MB, the partition size will be calculated by the above formula as follows:

$$4100\text{MB} + (512\text{MB} * 1.5) + (512\text{MB} + 1\text{MB}) + \text{Application Size} \\ = 5381\text{MB} + \text{Application Size}$$

Dividing into the partition of the recommended size into multiple disks as written below will solve problem that it cannot be reserved in one disk.

1. Set the "Size required for installation + Paging file size".
2. See Chapter 5 and set that debugging information (equivalent to the dump file size) is to be written to a separate disk.

(If the disk does not have enough free space to enable the dump file size to be written, then after installing the system using the "Size required for installation + Paging file size", install an additional new disk.)

## **INSTALLING WINDOWS SERVER 2003 X64 EDITIONS**

### Preparations for Installation

- NEC EXPRESSBUILDER DVD
- Microsoft Windows Server 2003 R2 Standard x64 Edition (CD-ROM)
- Windows Server 2003 x64 Editions Service Pack 2 (CD-ROM)
- User's Guide
- Getting Started
- Windows Server 2003 x64 Edition OEM-Disk for EXPRESSBUILDER

---

## Creating "Windows Server 2003 x64 Edition OEM-Disk for EXPRESSBUILDER"

Before installing, create Windows Server 2003 x64 Edition OEM-Disk for EXPRESSBUILDER.

---

**NOTE:** If you have already "Windows Server 2003 x64 Edition OEM-Disk for EXPRESSBUILDER" for NEC Express5800 Server which you are going to install Windows Server 2003 x64 Editions, you do not need to create it again.

---

You can create Windows Server 2003 x64 Edition OEM-Disk for EXPRESSBUILDER with the following two procedures.

- Create from the menu which appears when running NEC Express5800 Server with NEC EXPRESSBUILDER.

If you have only NEC Express5800 Server to create Windows Server 2003 x64 Edition OEM-Disk for EXPRESSBUILDER, use this procedure.

If Windows Server 2003 can be operated on NEC Express5800 Server, you can use the other procedure described later.

Follow the steps below.

1. Prepare one 3.5-inch floppy disk.
2. Turn on your NEC Express5800 Server.
3. Insert the NEC EXPRESSBUILDER DVD into the optical disk drive of the server.
4. Press the RESET switch or press **Ctrl, Alt** and **Delete** to reboot the server. (You may also turn off and then on again to reboot the server.)

The system will boot from the DVD-ROM and NEC EXPRESSBUILDER starts.

5. Select [Create the OEM-Disk for Windows] from [Tools Menu] step.
6. Select [Create a Windows Server 2003 x64 Editions OEM-Disk for EXPRESSBUILDER] at [Create OEM-Disk] and click [Perform].
7. Insert a floppy disk into the floppy disk drive according to the instruction on the screen.

Windows Server 2003 x64 Edition OEM-Disk for EXPRESSBUILDER will be created.

Write-protect and attach a label, then keep it safely.

■ Create from [Autorun Menu]

This menu requires Microsoft Windows XP, Vista or Windows Server 2003(or later).

You can create Windows Server 2003 x64 Edition OEM-Disk for EXPRESSBUILDER from [Autorun Menu], if you have the computer on which the above operating systems operate.

Follow the steps below.

1. Prepare one 3.5-inch floppy disk.
2. Start the Operating System.
3. Insert the NEC EXPRESSBUILDER DVD into the optical disk drive of the server.  
The Menu will appear.
4. Click [Create drive disk] and select [OEM-Disk for Windows Server 2003 x64 Edition].

---

**NOTE:** You can do the same operation with the menu appeared by the Right-click.

---

5. Insert the floppy disk into the floppy disk drive according to the message.  
Windows Server 2003 x64 Edition OEM-Disk for EXPRESSBUILDER will be created.  
Write-protect and attach a label, then keep it safely.

---

## Windows Server 2003 x64 Editions Clean Installation

This section explains how to perform a clean installation of Windows Server 2003 x64 Editions.

1. Turn on the system power.
2. Insert the Windows Server 2003 x64 Editions CD-ROM into the optical disk drive.
3. Press **Ctrl + Alt + Delete** to reset the system.

After a bootable operating system has been installed on the hard disk drive, press **Enter** while the message "Press any key to boot from CD..." is displayed at the top of the screen.

If no bootable operating system exists on the hard disk drive, this step is unnecessary.

The Windows Server 2003 x64 Editions setup screen will appear.

If the screen is not displayed, **Enter** was not pressed properly.

Begin after turning on the system power again.

4. Press **F6** in a few seconds when the window is in either of the following states.
  - "Setup is inspecting your computer's hardware configuration ..." or "Press F6 if you need to install a third party SCSI or RAID driver..." is displayed.
  - A screen with a solid blue background is displayed.

---

**IMPORTANT:** There is no visible indication on screen when **F6** has been pressed.

---

5. When the following message is displayed, press **S**.

Setup could not determine the type of one or more mass storage devices installed in your system, or you have chosen to manually specify an adapter. Currently, Setup will load support for the following mass storage device(s).

The following message is displayed.

Please insert the disk labeled  
manufacturer-supplied hardware support disk  
into Drive A:  
\*Press ENTER when ready.

6. Insert the Windows Server 2003 x64 Edition OEM-Disk for EXPRESSBUILDER into the floppy disk drive, and press **Enter**.

A list of mass storage devices is displayed.

If you utilize LSI Embedded MegaRAID, go on the step 8.
7. Select the [Intel(R) ICH9 SATA AHCI Controller (Desktop/Server/Workstation)] and press **Enter**.

8. Select the proper SCSI Adapter and press **Enter**.
  - [LSI MegaRAID SAS RAID Controller Driver (Server 2003 for x64)]  
(When N8103-117 board is installed.)
  - [LSI MegaRAID SAS RAID Controller Driver (Server 2003 for x64)]  
(When N8103-116 board is installed.)
  - [LSI Embedded MegaRAID (Windows XP/2003 64-bit)]  
(When LSI Embedded MegaRAID™ is used.)
9. If you utilize N8103-75/107, select the [Adaptec Ultra320 SCSI Cards (Windows 64-bit)] and press **Enter**.

---

**IMPORTANT:** If you utilize N8103-75/107, press **S** to proceed when the message below is shown.

The driver you provided seems to be newer than the Windows default driver.

Windows already has a driver that you can use for "Adaptec Ultra320 SCSI Cards (Windows 64-bit)".

Unless the device manufacturer prefers that you use the driver on the floppy disk, you should use the driver in Windows.

---

Continue performing tasks according to the subsequent messages that appear.

10. When the following message is shown, press **Enter** to start "Welcome to Setup".



---

**IMPORTANT:** If you install Windows Server 2003 x64 Editions on the hard disk larger than 2,097,152MB (2TB), you can specify only a value equal to or less than 2,097,152MB as partition size.

---

11. When the installation of Windows Server 2003 x64 Editions has finished, the system reboots automatically.

12. The [Windows Setup] screen will be displayed after logged on to the system.



---

**IMPORTANT:**

- In this case, the [Windows Setup] screen may not be displayed. Be sure to install Microsoft Windows Server 2003 R2 x64 Edition DISC 2 according to the following procedures.
  - You can install Microsoft Windows Server 2003 R2 x64 Edition DISC 2 after the application of "System update". Be sure to install Microsoft Windows Server 2003 R2 x64 Edition DISC 2. In this case, note that the [Windows Setup] screen is not displayed.
- 

13. Insert Microsoft Windows Server 2003 R2 x64 Edition DISC 2 CD-ROM into the optical disk drive.

Confirm the parameters and click [OK].

14. When the installation has completed, remove Microsoft Windows Server 2003 R2 x64 Edition DISC 2 CD-ROM from the optical disk drive, and restart the system.

After installation is completed, be sure to execute the tasks described in "Driver Installation and Advanced Settings" and "Updating the System" of this manual.

---

## Reinstallation to Multiple Logical Drives

This subsection describes the procedure for reinstalling the operation system if the multiple logical drives exist.

### Before Re-installing the Operation System

Be sure to make backup copies before re-installing the operation system just in case.

### Re-installing the Operation System

1. Start the clean installation following the procedure described in this manual.
2. Specify the partition in which you want to install the operating system when the following message appears:

The following list shows the existing partitions and unpartitioned space on this computer.

Use the UP and DOWN ARROW keys to select an item in the list.

\* Cannot modify the drive letter of your system or boot volume. Confirm the proper drive letter is assigned and then, continue the setup.

3. Continue the clean installation again following the procedure described earlier in this chapter.

The drive letter of the re-installed system may differ from the one of the previous system. If you need to modify the drive letter, modify it according to the "Procedure for Modifying the Drive Letter".

## Procedure for Modifying the Drive Letter

Be careful that the drive letter of the system or boot volume cannot modify with the following procedure.

1. Click Start menu, right-click [My Computer], and specify [Manage] to start [Computer Management].
2. Specify the [Disk Management] in the left side of the window.
3. Right-click the volume you want to modify the drive letter and specify the [Change Drive Letter and Path...].
4. Click [Yes].
5. Choose the [Assign a drive letter] and specify the drive letter you want to assign.
6. Click [OK].
7. If the following message appears, click [Yes].

Changing the drive letter of a volume may cause programs to no longer run. Are you sure you want to change this drive letter?

8. Close the [Computer Management].

---

## Procedure for License Authentication

Product Key used in the procedure for license authentication should be matched with the COA label in which the product key contained in Windows Server 2003 is written.

---

### NOTES:

- Execute the activation within 30 days. System may be locked after 30 days is passed.
  - COA label may be attached to your server.
-

---

## Updating the System - Applying Service Pack -

Update the system in the situation below:

- CPU is expanded (expanded to single processor to multi-processor).
- Modified system configuration.
- Recovered the system using recovery process.

The system update brings the correction program provided by Microsoft to be applied to reinforce the system security. The system update is recommended.

It is necessary to use ServicePack2 or more. ServicePack 2 need not be applied again when Windows Server 2003 x64 Editions CD-ROM where ServicePack 2 is included is used and it is installed.

If you install Windows Server 2003 x64 Editions CD-ROM which contains Service Pack 2, you do not have to apply "Hotfix for Windows x64" or "Hotfix for Windows Server 2003 (KB921411)".

Go on the section of "Updating the System".

Perform "Updating the System" and application of the "Hotfix (KB921411)".

---

**IMPORTANT:** In the situation below, make sure to apply "Updating the System" and "Hotfix (KB921411)".

- Modified system configuration
  - Recovered the system using recovery process.
- 

---

**NOTE:** If you use Windows Server 2003 x64 Editions CD-ROM which includes Service Pack 2, the application of "Hotfix (KB921411)" is not required.

---

## Application Process of the Hotfix (KB921411)

Apply the "Hotfix (KB921411)" before execute "Updating the System".

1. Log on to the system by the account with administrator authority to the server (such as administrator).
2. Insert the NEC EXPRESSBUILDER DVD into the optical disk drive of the server.
3. Click Start menu and [Run], and then execute the following command.

```
<When Windows Server 2003 x64 Editions is used>  
\\006\win\winnt\w2k3amd\qfe\enu\kb921411.exe
```

4. When the following message is displayed, click [Next].  
After that, follow the message to continue the process.

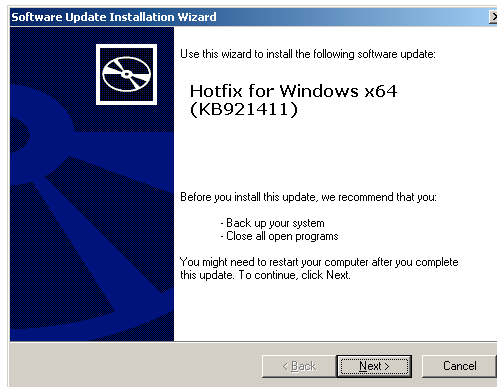

5. When the following message is displayed, make sure to click [Finish] to restart the system.

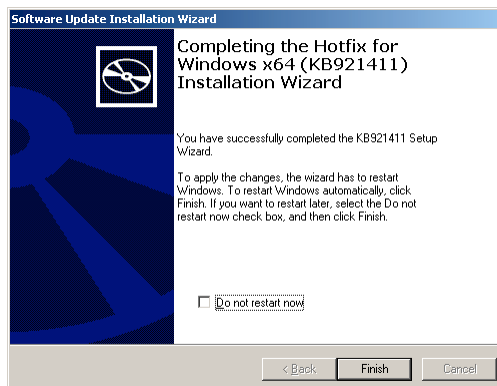

With that, application process of the Hotfix (KB921411) is finished.

## Application Process of "Updating the System"

"Updating the System" applies the drivers necessary for NEC Express5800 Series.

Follow this process after Hotfix for Windows x64 (KB921411) or Hotfix for Windows Server 2003 (KB921411) had been applied.

---

**NOTE:** If you install Windows CD-ROM that contains Service Pack 2 to your system, you do not have to apply Service pack 2 again.

---

1. Log on to the system with the account that has administrative privilege (e.g. administrator).
2. Insert the NEC EXPRESSBUILDER DVD into the optical disk drive of server.  
The Menu will be displayed
3. Left-click on [Setup Windows], and then click [Update the system].

---

**NOTE:** Right-clicking on the Autorun Menu produces the same outcome.

---

Follow the message of the screen to proceed the application.

[OK] dialog box will be displayed.

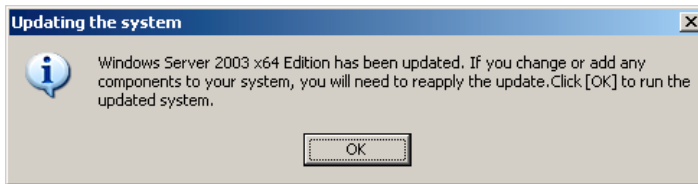

**IMPORTANT:** During the "Updating the System", the following message may be shown, but there is no impact to the operation. Do not click [cancel] since it may be taken away after a few seconds.



- 
4. Click [OK] to restart the system.
  5. When the reboot is started, remove the NEC EXPRESSBUILDER DVD from the optical disk drive immediately.

## Recovery Process

If "Updating the System" is executed before the application of the "Hotfix for Windows x64 (KB921411)", "!" may be displayed on the USB root hub.

If "!" is displayed on the USB root hub, perform application of the "Hotfix for Windows x64 (KB921411)" and the "Updating the System" according to the following process.

1. Start the Windows Explorer, and click [Tools] and [Folder Options].
2. Select [Files and Folders] - [Hidden files and folders] - [Show hidden files and folders] radio button from Advanced settings in the [View] tab.
3. Check off the following check box in the [Files and Folders] from Advanced settings in the [View] tab, and then click [OK].

Hide extensions for know file type

Hide protected operating system files [Recommended]

When the message "You have chosen to display protected operating system files..." is displayed, click [Yes].

4. Make sure of the files.

Open "<System drive:>\WINDOWS\system32\drivers" directory, and make sure usbhub.sys and usbport.sys are exists in the directory.

If you can not found them, copy the files according to the following process.

(1) Open "<System drive:>\WINDOWS\system32\dllcache" directory.

(2) Copy usbhub.sys and usbport.sys from the directory noted above to "<System drive:>\WINDOWS\system32\drivers".

5. Restart the system.
6. Refer to [Application process of the Hotfix (KB921411)] and apply the "Hotfix for Windows x64 (KB921411)".
7. Refer to [Application process of "Updating the System"] and execute "Updating the System".
8. Restart the system.

With that, process is finished.

## DRIVER INSTALLATION AND ADVANCED SETTINGS

This section describes on how to install and setup various standard drivers mounted on the device.

For the information on installing and setting up the driver that is not described in this section, please refer to the document attached to the driver.

---

### PROSet

---

**NOTE:** All of the operation that related to Intel® PROSet is must be execute by administrator privileges. Operation by [Remote Desktop Connection] is prohibited.

Without changing any parameter when opened the properties of adapter teaming, please click the [Cancel] button for close the dialog.

Click [OK] button will cause temporary loss of network connectivity.

---

PROSet is a utility that confirms the function of network contained in network driver.

Utilizing PROSet enables the following items:

- Confirm detailed information of the adapter.
- Diagnose loop back test, packet transmission test and so on.
- Setup of teaming.

Configuring several network adapters as one team provides the server a tolerant environment on any trouble and enhances throughput between the switches.

PROSet is necessary to utilize these features.

Follow the procedure below to install PROSet.

1. Insert the NEC EXPRESSBUILDER DVD into the optical disk drive.  
If the autorun menu is displayed, close menu screen.
2. The [Windows Explorer] dialog starts.
  - \* The procedure in the case of the standard start menu  
Click Start menu and click [Windows Explorer].
  - \* The procedure in the case of the classic start menu  
Click Start menu, point to [Programs], [Accessories] and click [Windows Explorer].
3. Run "dxsetup.exe" in the following directory.  
\\006\win\winnt\w2k3amd\dl3\proset\winx64  
The [Intel(R) PROSet - InstallShield Wizard] dialog starts.
4. Click [Next].

5. Choose "I accept the terms in the license agreement" and click [Next].
6. Click [Next].
7. Choose "I accept the terms in the license agreement" and click [Next].
8. Click [Install].
9. When [InstallShield Wizard Completed] window is displayed, click [Finished].
10. Remove the NEC EXPRESSBUILDER DVD from the optical disk drive, restart the system.

---

## Adapter Fault Tolerance (AFT)/Adaptive Load Balancing (ALB)

Adapter Fault Tolerance (AFT) is a feature that creates a group containing more than one adapter and automatically converts the process of the working adapter to the other adapter in the group when any trouble occurred on that adapter.

Adaptive Load Balancing (ALB) is a feature that creates a group containing more than one adapter and enhance the through put by operating packet transmission from the server by all the adapters.

This feature includes AFT feature.

---

### IMPORTANT:

- AFT/ALB setup must be operated after installing the drivers and restarting the system.
  - All the adapters specified as a group of Adapter Teaming must exist on the same LAN. If they are connected to the separate switches, they will not work normally.
  - The adapters specified as a group of Adaptive Load Balancing (ALB) can be connected to only Switching Hub.
  - When exchange the mother board or option network card, make sure to remove the adapter team before exchanges and recreate the adapter team after exchange complete.
- 

If you want to utilize AFT/ALB feature, follow the procedure below to setup.

1. The [Intel (R) PROSet] dialog box appears.
  - \* The procedure in the case of the standard start menu  
Click Start menu, point to [Control Panel], [administrative tools], and click [Computer Management] and then double click the [(Network Adapter Name)] in the Network Adapter list.
  - \* The procedure in the case of the classic start menu
    1. Click Start menu, point to [Settings] and click [Control Panel].
    2. Click [administrative tools].
    3. Click [Computer Management] and double click the [(Network Adapter Name)] in the Network Adapter list.
2. Select [Teaming] tab and then check on [Team with other adapters] and click [New Team...].

The [New Team Wizard] dialog box appears and click [Next].

  - \* Specify a name for the team if it necessary.
3. Select the adapters to include in team.
4. Select "Adapter Fault Tolerance" or "Adaptive Load Balancing" and click [Next].
5. Click [Finish].

- 6.** If necessary to set the adapter priority setting, refer the following step. If not, go through to step 7.
  1. Click [Settings] tab on [TEAM:xxx #yy Properties].
  2. Click [Modify Team].
  3. Point to the adapter [Intel(R)PRO/1000....] and click [Set Primary] or [Set Secondary].
  4. Click [OK].
  5. The setup will go back to [EAM:xxx #yy Properties] and the priority setting will display in list ().
  6. Click [OK].
- 7.** The setup will go back to [Intel (R) PROSet for Wired Connections] dialog box, so click [OK].
- 8.** Restart the system.

## Network Driver

Specify the details of network driver.

One standard network driver that is mounted will be installed automatically, but the link speed and Duplex mode need to be specified manually.

IP addresses is not be able to set when the "Internet Protocol (TCP/IP)" check box OFF.

This phenomenon will occur with the certain condition.

Check ON the "Internet Protocol (TCP/IP)" check box and IP address will be able to set.

[When PROSet is not installed]

- 1.** The [Local Area Connection Properties] dialog box appears.
  - \* The procedure in the case of the standard start menu
    - 1) Click Start menu, click [Control Panel], click [Network Connections], and click [Local Area Connection].
  - \* The procedure in the case of the classic start menu
    - 1) Click Start menu, click [Settings] and click [Network Connections].

The [Network Connections] dialog box appears.
    - 2) Right-click [Local Area Connection] and click [Properties] from pop-up menu.
- 2.** Click [Configure].

The property dialog box for network adapter appears.
- 3.** Click the [Advanced] and specify the [Link Speed & Duplex] value the same as the value specified for HUB.
- 4.** Click [OK] on the property dialog box for network adapter.

[When PROSet is installed]

1. The [Intel(R) PROSet] dialog box appears.
  - \* The procedure in the case of the standard start menu  
Click Start menu, point to [Control Panel], [administrative tools], and click [Computer Management] and then double click the [(Network Adapter Name)] in the Network Adapter list.
  - \* The procedure in the case of the classic start menu
    1. Click Start menu, point to [Settings] and click [Control Panel].
    2. Click [administrative tools].
    3. Click [Computer Management] and double click the [(Network Adapter Name)] in the Network Adapter list.
2. Click the [Link] and specify the [Speed and Duplex] value the same as the value specified for HUB.
3. Click [Apply] and click [OK].

Also, add or delete any protocols and services if necessary.

You can operate the process on the property dialog box for local area network which can be appeared from [Network and Dial-up Connection].

---

**NOTE:** We recommend you to add [Network Monitor] at [Adding Services]. [Network Monitor] can monitor the frame (or the packet) that the computer installing [Network Monitor] sends or receives. This tool is valuable when analyzing network trouble. For information on how to install the tool, see the "Setting for Solving Problems" described later in this chapter.

---

---

## Re-install the Network Driver

The network driver will be installed automatically.

---

## Optional Network Board Driver

If you want to utilize optional Network Board (N8104-112/119/111/120/121/125/126), the network driver will be installed automatically. Therefore, the driver attached to the Network board should not be used.

If you want to utilize optional Network Board, install the driver stored in NEC EXPRESSBUILDER DVD.

In case of utilizing (N8104-111)

"\006\win\winnt\w2k3amd\dl3\pro100\winx64"

In case of utilizing (N8104-112/119/120/121/125/126)

"\006\win\winnt\w2k3amd\dl3\pro1000\winx64"

---

## Installation of the Optional Network Board Driver

1. Start Device Manager.
2. Click [Network adapters] and double-click [(Network Adapter Name)].  
[(Network Adapter Name) Properties] appears.

---

**NOTE:** [(Intel (R) PRO/1000...)] is the name of On-Board adapter. All other names show the Optional Network Board.

---

3. Click [Driver] tab and click [Update Driver...]. [Hardware Update Wizard] appears.
4. Select the [Install from a list or specific location (Advanced)] radio button and click [Next].
5. Select the [Search for the best driver in these locations] radio button and check off the [Search removable media (floppy, CD-ROM...)] check box.
6. Check the [Include this location in the search] check box and when using [(N8104-111)], specify  
[\006\win\winnt\w2k3amd\dl3\pro100\winx64].  
Then click [Next].  
When using [(N8104-112/119/120/121/125/126)], specify  
[\006\win\winnt\w2k3amd\dl3\pro1000\winx64].  
Then click [Next].
7. Click [Finish].

---

## Graphics Accelerator Driver

If you utilize standard graphics accelerator drivers, update your system with NEC EXPRESSBUILDER DVD attached to your system. Standard graphics accelerator drivers will be installed automatically.

Please follow the following procedure when you want to re-install the driver individually.

1. Insert the NEC EXPRESSBUILDER DVD into the optical disk drive.  
If the autorun menu is displayed, close menu screen.
2. Click Start menu, point to [Programs], [Accessories] and click [Windows Explorer].
3. Run "setup.exe" in the following directory.  
\\006\win\winnt\w2k3amd\video\setup.exe
4. Follow the message to continue the installation.  
If the dialog message "Digital Signature could not been found." appears, select [Yes] to continue.
5. Remove the NEC EXPRESSBUILDER DVD from the optical disk drive, restart the system.

---

## Installing SCSI Controller Driver (N8103-75/107)

If you utilize SCSI controller driver (N8103-75/107), update your system with NEC EXPRESSBUILDER DVD attached to your system.

The SCSI controller driver will be installed automatically.

---

## Installing SCSI Controller Driver (N8103-95)

The SCSI controller driver will be installed automatically.

## About Windows Activation

Windows Server 2003 x64 Editions must be activated before you can use Windows Server 2003 x64 Editions.

Windows activation process is as follows.

1. Click [Run] on [Start] menu.  
Type as follows in the [Open:] box, and click [OK].  
oobe/msoobe /a

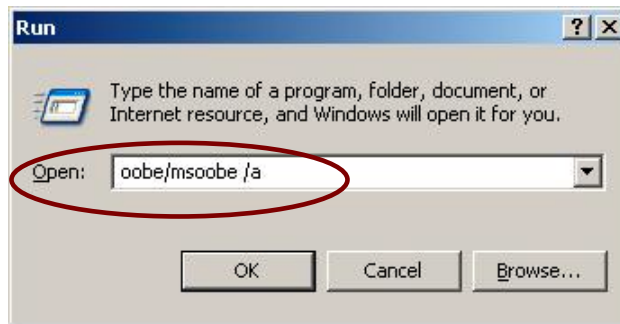

2. When the screen as follows is displayed, click [Next].

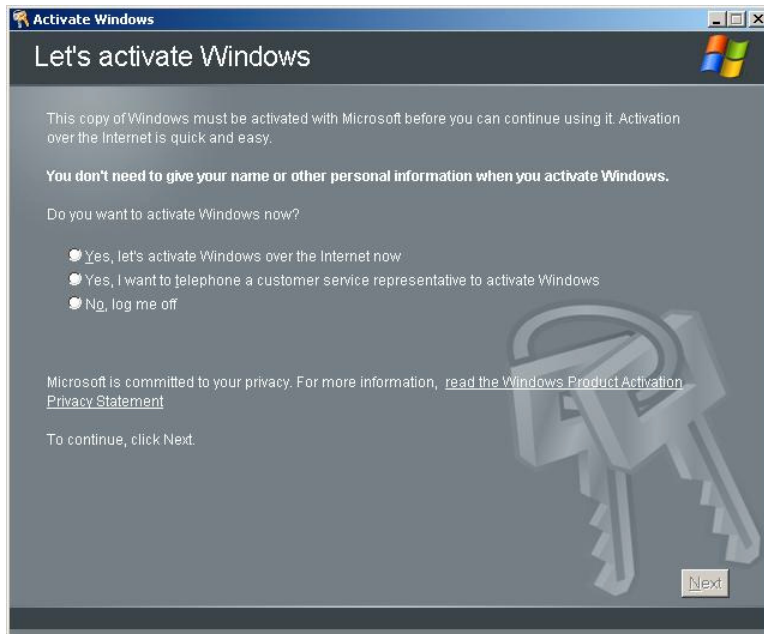

The following screen is displayed.



3. Process "Windows activation" according to the following message.



## SETTING FOR COLLECTING MEMORY DUMP (DEBUG INFORMATION)

Set for collecting memory dump using the procedure described in Chapter 5.

# Appendix E

---

## Installing Windows Server 2003

This section describes the procedures for installing Windows Server 2003 without using Express Setup tool.

### BEFORE INSTALLING WINDOWS SERVER 2003

Read the following notes or information before installing the Windows Server 2003.

---

#### Optional Board Supported by NEC EXPRESSBUILDER

The NEC EXPRESSBUILDER DVD attached to your server supports the following optional boards;

---

**NOTE:** If you want to install the other boards by using a driver floppy disk ("OEM-FD for Mass storage device"), except ones listed below, see "Installing with the OEM-FD for Mass storage device" and "Installing Optional Mass Storage Driver" of "Parameter File Creator" in Chapter 6.

---

- Controllers supporting installation of OS with Express Setup
    - N8103-116 RAID controller (128 MB, RAID0/1)
    - N8103-117 RAID controller (128 MB, RAID0/1/5/6)
    - LSI Embedded MegaRAID™ (embedded on the mother board)
  - Other controllers
    - N8103-75 SCSI Controller\*
    - N8103-95 SCSI Controller\*
    - N8103-107 SCSI Controller\*
- \* Option

---

## **Service Pack Which EXPRESSBUILDER Supports**

The EXPRESSBUILDER DVD attached to the server supports following combination of the OS installation media and Service Pack.

- Windows Server 2003 R2
  - OS installation media (with Service Pack 2)
  - OS installation media (No Service Pack) + Service Pack 2
  - OS installation media (No Service Pack)
- Windows Server 2003
  - OS installation media (with Service Pack 1)
  - OS installation media (with Service Pack 1) + Service Pack 2

---

## **Installing Service Pack**

You can install the Service Pack on the server. When the Service Pack is not attached to your system, prepare it by yourself.

When installing Windows Server 2003 R2, it is not necessary to apply Service Pack 1.

---

## **Updating System**

If you modified the Windows system, execute "Update the System" in Autorun Menu.

---

## **Re-installing to the Hard Disk Drive which has been upgraded to Dynamic Disk**

If you want to leave the existing partition when installing the system on the hard disk drive upgraded to Dynamic Disk, note the following issue:

- Do not select the partition that OS had been installed as the partition to install the OS newly.
- Select "Use the current File System" for the format of OS partition.

---

## Mounting MO Device

Do not mount an MO device on your server during the Windows installation.

---

## About Removable Media

Do not set removable media, such as DAT, into the device mounted on your server during the OS installation.

---

## About the Upgrade to Windows Server 2003 R2

The "in-place upgrade" from Windows Server 2003 to Windows Server 2003 R2 is not recommended because it may overwrite any files or registries, and cause unexpected impact to the system or the applications.

If you install Windows Server 2003 R2, backup user data referring "Windows Server 2003 Clean Installation", and reinstall Windows Server 2003 R2.

---

**NOTE:** "in-place upgrade" is to perform overwrite upgrade from Windows Server 2003 which already installed to Windows Server 2003 R2.

---

---

## About the System Partition Size

The system partition size can be calculated from the following formula.

Size necessary to install the system + Paging File Size + Dump File Size  
+ Application Size  
Size necessary to install the system = 3500MB (Windows Server 2003 R2)  
= 3500MB (Windows Server 2003 with ServicePack  
1)  
= 3500MB (Windows Server 2003 R2 with Service  
Pack2)  
= 5300MB (Windows Server 2003 R2 + ServicePack  
2)  
= 5300MB (Windows Server 2003 with Service Pack  
1 + ServicePack 2)  
Paging File Size (Recommended) = Mounted Memory Size \* 1.5  
Dump file Size = Mounted Memory Size + 12MB  
Application Size = Required Size

---

### IMPORTANT:

- The above-mentioned paging file size is recommended for collecting debug information (memory dump). The paging file with initial size large enough to store the dump file in the boot drive is required.  
Correct debug information might not be able to be collected due to virtual memory shortage when the paging file is insufficient, so set an enough size of the paging file with the entire system.
  - The maximum paging file size which can be set on one partition is 4095MB. If the above paging file size exceeds 4095MB, specify 4095MB for the paging file size.
  - The maximum dump file size for the system with more than 2GB memory mounted is '2048MB + 12MB'.
  - If you install any application program or the like, add necessary space to the partition to install these programs.
- 

For example, if the mounted memory size is 512MB, the partition size will be calculated by the above formula as follows:

$3500\text{MB} + (512\text{MB} * 1.5) + (512\text{MB} + 12\text{MB}) + \text{Application Size}$   
 $= 4792\text{MB} + \text{Application Size}$

Dividing into the partition of the recommended size into multiple disks as written below will solve problem that it cannot be reserved in one disk.

1. Set the "Size required for installation + Paging file size".
2. See Chapter 5 and set that debugging information (equivalent to the dump file size) is to be written to a separate disk.  
(If the disk does not have enough free space to enable the dump file size to be written, then after installing the system using the "Size required for installation + Paging file size", install an additional new disk.)

## **INSTALLING WINDOWS SERVER 2003**

### Preparations for Installation

- NEC EXPRESSBUILDER DVD
- Microsoft Windows Server 2003 Standard Edition (CD-ROM), Microsoft Windows Server 2003 R2 Standard Edition (CD-ROM)
- Windows Server 2003 Service Pack 2 (CD-ROM)
- User's Guide
- Getting Started
- Windows Server 2003 OEM-Disk for EXPRESSBUILDER

---

## Creating "Windows Server 2003 OEM-Disk for EXPRESSBUILDER"

Before installing, create Windows Server 2003 OEM-Disk for EXPRESSBUILDER.

---

**NOTE:** If you have already "Windows Server 2003 OEM-Disk for EXPRESSBUILDER" for NEC Express5800 Server which you are going to install Windows Server 2003, you do not need to create it again.

---

You can create Windows Server 2003 OEM-Disk for EXPRESSBUILDER with the following two procedures.

- Create from the menu which appears when running NEC Express5800 Server with NEC EXPRESSBUILDER.

If you have only NEC Express5800 Server to create Windows Server 2003 OEM-Disk for EXPRESSBUILDER, use this procedure.

If Windows Server 2003 or Windows can be operated on NEC Express5800 Server, you can use the other procedure described later.

Follow the steps below.

1. Prepare one 3.5-inch floppy disk.
2. Turn on your NEC Express5800 Server.
3. Insert the NEC EXPRESSBUILDER DVD into the optical disk drive of the server.
4. Press the RESET switch or press **Ctrl, Alt** and **Delete** to reboot the server. (You may also turn off and then on again to reboot the server.)

The system will boot from the DVD-ROM and NEC EXPRESSBUILDER starts.

5. Select [Create the OEM-DISK for Windows] from [Tools Menu] step.
6. Select [Create a Windows Server 2003 OEM-Disk for EXPRESSBUILDER] at [Create OEM-Disk] and click [Perform].
7. Insert a floppy disk into the floppy disk drive according to the instruction on the screen.

Windows Server 2003 OEM-Disk for EXPRESSBUILDER will be created.

Write-protect and attach a label, then keep it safely.

- Create from [Autorun Menu]

This menu requires Microsoft Windows XP, Vista or Windows Server 2003 (or later).

You can create Windows Server 2003 OEM-Disk for EXPRESSBUILDER from [Autorun Menu], if you have the computer on which the above operating systems operate.

Follow the steps below.

1. Prepare one 3.5-inch floppy disk.
2. Start the Operating System.
3. Insert the NEC EXPRESSBUILDER DVD into the optical disk drive of the server.  
The Menu will appear.
4. Click [Create drive disk] and select [OEM-Disk for Windows Server 2003].

---

**NOTE:** You can do the same operation with the menu appeared by the Right-click.

---

5. Insert the floppy disk into the floppy disk drive according to the message.  
Windows Server 2003 OEM-Disk for EXPRESSBUILDER will be created.  
Write-protect and attach a label, then keep it safely.

---

## Windows Server 2003 Clean Installation

This section explains how to perform a clean installation of Windows Server 2003.

1. Turn on the system power.
2. Insert the Windows Server 2003 CD-ROM into the optical disk drive.
3. Press **Ctrl + Alt + Delete** to reset the system.

After a bootable operating system has been installed on the hard disk drive, press **Enter** while the message "Press any key to boot from CD..." is displayed at the top of the screen.

If no bootable operating system exists on the hard disk drive, this step is unnecessary.

The Windows Server 2003 setup screen will appear.

If the screen is not displayed, **Enter** was not pressed properly.

Begin after turning on the system power again.

4. Press **F6** in a few seconds when the window is in either of the following states.
  - "Setup is inspecting your computer's hardware configuration ..." or "Press F6 if you need to install a third party SCSI or RAID driver..." is displayed.
  - A screen with a solid blue background is displayed.

---

**IMPORTANT:** There is no visible indication on screen when **F6** has been pressed.

---

5. When the following message is displayed, press **S**.

Setup could not determine the type of one or more mass storage devices installed in your system, or you have chosen to manually specify an adapter. Currently, Setup will load support for the following mass storage device(s).

The following message is displayed.

Please insert the disk labeled  
manufacturer-supplied hardware support disk  
into Drive A:  
\*Press ENTER when ready.

6. Insert the Windows Server 2003 OEM-Disk for EXPRESSBUILDER into the floppy disk drive, and press **Enter**.

A list of mass storage devices is displayed.

If you utilize LSI Embedded MegaRAID, go on the step 8.

7. Select the [Intel(R) ICH9 SATA AHCI Controller (Desktop/Server/Workstation)] and press **Enter**.

8. Select the proper SCSI Adapter and press **Enter**.
  - [LSI Logic MegaRAID SAS RAID Controller Driver (Server 2003 32-bit)]  
(When N8103-117 board is installed.)
  - [LSI Logic MegaRAID SAS RAID Controller Driver (Server 2003 32-bit)]  
(When N8103-116 board is installed.)
  - [LSI Embedded MegaRAID (Windows XP/2003)]  
(When LSI Embedded MegaRAID™ is used.)
9. If you utilize N8103-75/107, select the [Adaptec Ultra320 SCSI Card (Windows 32-bit)] and press **Enter**.

---

**IMPORTANT:** If you utilize N8103-75/107, press **S** to proceed when the message below is shown.

The driver you provided seems to be newer than the Windows default driver.

Windows already has a driver that you can use for "Adaptec Ultra320 SCSI Card (Windows 32-bit)".

Unless the device manufacturer prefers that you use the driver on the floppy disk, you should use the driver in Windows.

- 
10. If you utilize N8103-95, select the [Adaptec Ultra160 SCSI Cards (Win Server 2003)] and press **Enter**.

---

**IMPORTANT:** If you utilize N8103-95, press **S** to proceed when the message below is shown.

The driver you provided seems to be newer than the Windows default driver.

Windows already has a driver that you can use for "Adaptec Ultra160 SCSI Cards (Win Server 2003)".

Unless the device manufacturer prefers that you use the driver on the floppy disk, you should use the driver in Windows.

---

Continue performing tasks according to the subsequent messages that appear.

11. When the following message is shown, press **Enter** to start "Welcome to Setup".

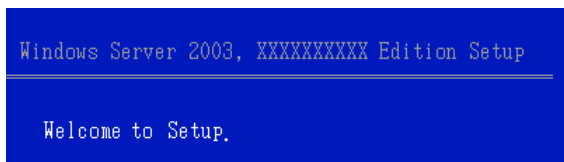

---

**IMPORTANT:** If you install Windows Server 2003 on the hard disk larger than 2,097,152MB (2TB), you can specify only a value equal to or less than 2,097,152MB as partition size.

---

12. When the installation of Windows Server 2003 has finished, the system reboots automatically.
- Windows Server 2003 has been installed: Go on the step 14.
  - Windows Server 2003 R2 has been installed: Go on the step 11.
13. When Windows Server 2003 R2 has been installed, the [Windows Setup] screen will be displayed after logged on to the system.



---

**IMPORTANT:**

- In this case, the [Windows Setup] screen may not be displayed. Be sure to install Microsoft Windows Server 2003 R2 DISC 2 according to the following procedures.
  - You can install Microsoft Windows Server 2003 R2 DISC 2 after the application of "System update". Be sure to install Microsoft Windows Server 2003 R2 DISC 2. In this case, note that the [Windows Setup] screen is not displayed.
- 

14. Insert Microsoft Windows Server 2003 R2 DISC 2 CD-ROM into the optical disk drive. Confirm the parameters and click [OK].
15. When the installation has completed, remove Microsoft Windows Server 2003 R2 DISC 2 CD-ROM from the optical disk drive, and restart the system.
16. When the installation has completed, be sure to execute the tasks described in "Driver Installation and Advanced Settings" and "Updating the System" of manual.

---

## Reinstallation to Multiple Logical Drives

This subsection describes the procedure for reinstalling the operation system if the multiple logical drives exist.

### Before Re-installing the Operation System

Be sure to make backup copies before re-installing the operation system just in case.

### Re-installing the Operation System

1. Start the clean installation following the procedure described in this manual.
2. Specify the partition in which you want to install the operating system when the following message appears:

The following list shows the existing partitions and unpartitioned space on this computer.

Use the UP and DOWN ARROW keys to select an item in the list.

- \* Cannot modify the drive letter of your system or boot volume. Confirm the proper drive letter is assigned and then, continue the setup.

3. Continue the clean installation again following the procedure described earlier in this chapter.

The drive letter of the re-installed system may differ from the one of the previous system. If you need to modify the drive letter, modify it according to the "Procedure for Modifying the Drive Letter".

## Procedure for Modifying the Drive Letter

Be careful that the drive letter of the system or boot volume cannot modify with the following procedure.

1. Click Start menu, right-click [My Computer], and specify [Manage] to start [Computer Management].
2. Specify the [Disk Management] in the left side of the window.
3. Right-click the volume you want to modify the drive letter and specify the [Change Drive Letter and Path...].
4. Click [Yes].
5. Choose the [Assign a drive letter] and specify the drive letter you want to assign.
6. Click [OK].
7. If the following message appears, click [Yes].

Changing the drive letter of a volume may cause programs to no longer run. Are you sure you want to change this drive letter?
---

8. Close the [Computer Management].

---

## Re-installing the Operation System if Multiple Logical Drives Exist

### [Before Re-installing the Operation System]

Be sure to make backup copies before re-installing the operation system just in case.

### [Re-installing the Operation System]

1. Start the clean installation following the procedure described in this manual.
2. Specify the partition in which you want to install the operating system when the following message appears:

The following list shows the existing partitions and unpartitioned space on this computer.

Use the UP and DOWN ARROW keys to select an item in the list.

\* Cannot modify the drive letter of your system or boot volume. Confirm the proper drive letter is assigned and then, continue the setup.

3. Continue the clean installation again following the procedure described in this manual.
4. The drive letter of the re-installed system may differ from the one of the previous system. If you need to modify the drive letter, modify it according to the "Procedure for Modifying the Drive Letter".

### [Procedure for Modifying the Drive Letter]

Be careful that the drive letter of the system or boot volume cannot modify with the following procedure.

1. Click Start menu, right-click [My Computer], and specify [Manage] to start [Computer Management].
2. Specify the [Disk Management] in the left side of the window.
3. Right-click the volume you want to modify the drive letter and specify the [Change Drive Letter and Path...].
4. Click [Yes].
5. Choose the [Assign a drive letter] and specify the drive letter you want to assign.
6. Click [OK].
7. If the following message appears, click [Yes].

Changing the drive letter of a volume may cause programs to no longer run. Are you sure you want to change this drive letter?

8. Close the [Computer Management].

---

## Procedure for License Authentication

Product Key used in the procedure for license authentication should be matched with the COA label in which the product key contained in Windows Server 2003 is written.

---

### NOTES:

- Execute the activation within 30 days. System may be locked after 30 days is passed.
  - COA label may be attached to your server.
- 

---

## Updating the System - Applying Service Pack -

Update the system in the situation below:

- CPU is expanded (expanded to single processor to multi-processor).
- Modified system configuration.
- Recovered the system using recovery process.

The system update brings the correction program provided by Microsoft to be applied to reinforce the system security. The system update is recommended.

Service Pack 2 need not be applied again when Windows Server 2003 CD-ROM which Service Pack 2 is included is used and it is installed.

Go on the section of "Updating the System".

Perform "Updating the System" and application of the "Hotfix (KB921411)".

---

**IMPORTANT:** In the situation below, make sure to apply "Updating the System" and "Hotfix (KB921411)".

- Modified system configuration
  - Recovered the system using recovery process.
- 

---

**NOTE:** If you use Windows Server 2003 CD-ROM which includes Service Pack 2, the application of "Hotfix (KB921411)" is not required.

---

## Application Process of the Hotfix (KB921411)

Apply the "Hotfix (KB921411)" before execute "Updating the System".

1. Log on to the system by the account with administrator authority to the server (such as administrator).
2. Insert the NEC EXPRESSBUILDER DVD into the optical disk drive of the server.
3. Click Start menu and [Run], and then execute the following command.

<When the English version of Windows Server 2003 R2 is used>

```
\006\win\winnt\dotnet\qfe\enu\kb921411.exe
```

<When the Simplified Chinese version of Windows Server 2003 R2 is used>

```
\006\win\winnt\dotnet\qfe\chs\kb921411.exe
```

<When the French version of Windows Server 2003 R2 is used>

```
\006\win\winnt\dotnet\qfe\fra\kb921411.exe
```

4. When the following message is displayed, click [Next].

After that, follow the message to continue the process.

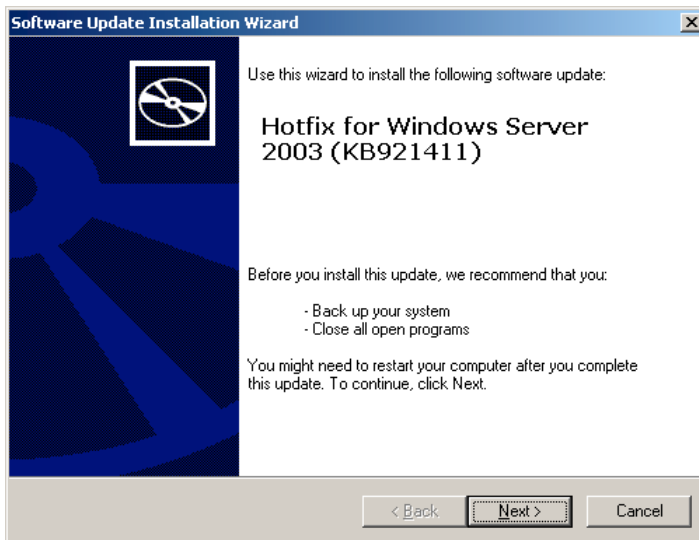

5. When the following message is displayed, make sure to click [Finish] to restart the system.

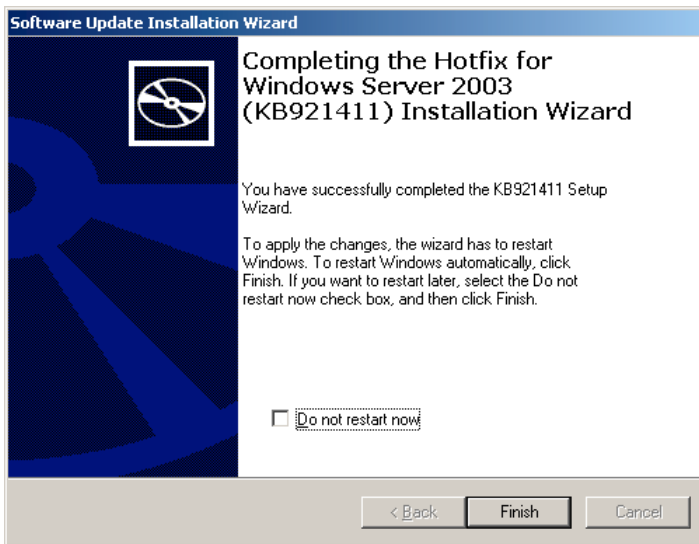

With that, application process of the Hotfix (KB921411) is finished.

## Application Process of "Updating the System"

"Updating the System" applies the drivers necessary for NEC Express5800 Series.

Follow this process after Hotfix for Windows Server 2003 (KB921411) had been applied.

---

**NOTE:** If you install Windows CD-ROM that contains Service Pack 2 to your system, you do not have to apply Service pack 2 again.

---

1. Log on to the system with the account that has administrative privilege (e.g. administrator).
2. Insert the NEC EXPRESSBUILDER DVD into the optical disk drive of server.  
The Windows Autorun Menu will be displayed
3. Left-click on [Setup Windows], and then click [Update the system].

---

**NOTE:** Right-clicking on the Windows Autorun Menu produces the same outcome.

---

Follow the message of the screen to proceed the application.

[OK] dialog box will be displayed.

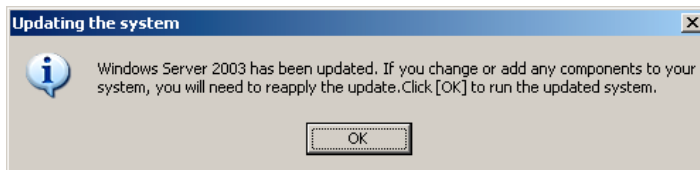

**IMPORTANT:** During the "Updating the System", the following message may be shown, but there is no impact to the operation. Do not click [cancel] since it may be taken away after a few seconds.



- 
4. Click [OK] to restart the system.
  5. When the reboot is started, Remove the NEC EXPRESSBUILDER DVD from the optical disk drive immediately.

## Recovery Process

If "Updating the System" is executed before the application of the "Hotfix for Windows Server 2003 (KB921411)", "!" may be displayed on the USB root hub.

If "!" is displayed on the USB root hub, perform application of the "Hotfix for Windows Server 2003 (KB921411)" and the "Updating the System" according to the following process.

1. Start the Windows Explorer, and click [Tools] and [Folder Options].
2. Select [Files and Folders] - [Hidden files and folders] - [Show hidden files and folders] radio button from Advanced settings in the [View] tab.
3. Check off the following check box in the [Files and Folders] from Advanced settings in the [View] tab, and then click [OK].
  - Hide extensions for know file type
  - Hide protected operating system files [Recommended]

When the message "You have chosen to display protected operating system files..." is displayed, click [Yes].

4. Make sure of the files.

Open "<System drive:>\WINDOWS\system32\drivers" directory, and make sure usbhub.sys and usbport.sys are exists in the directory.

If you can not found them, copy the files according to the following process.

- (1) Open "<System drive:>\WINDOWS\system32\dlldata" directory.
- (2) Copy usbhub.sys and usbport.sys from the directory noted above to "<Systemdrive:>\WINDOWS\system32\drivers".

5. Restart the system.
6. Refer to [Application process of the Hotfix (KB921411)] and apply the "Hotfix for Windows Server 2003 (KB921411)".
7. Refer to [Application process of "Updating the System"] and execute "Updating the System".
8. Restart the system.

With that, process is finished.

## DRIVER INSTALLATION AND ADVANCED SETTINGS

This section describes on how to install and setup various standard drivers mounted on the device.

For the information on installing and setting up the driver that is not described in this section, please refer to the document attached to the driver.

### **PROSet**

PROSet is a utility that confirms the function of network contained in network driver.

Utilizing PROSet enables the following items:

- Confirm detailed information of the adapter.
- Diagnose loop back test, packet transmission test and so on.
- Setup of teaming.

Configuring several network adapters as one team provides the server a tolerant environment on any trouble and enhance throughput between the switches.

PROSet is necessary to utilize these features.

Follow the procedure below to install PROSet.

1. Insert the NEC EXPRESSBUILDER DVD into the optical disk drive.  
If the autorun menu is displayed, close menu screen.
2. The [Windows Explorer] dialog starts.
  - \* The procedure in the case of the standard start menu  
Click Start menu and click [Windows Explorer].
  - \* The procedure in the case of the classic start menu  
Click Start menu, point to [Programs], [Accessories] and click [Windows Explorer].
3. Run "dxsetup.exe" in the following directory.  
\\006\win\winnt\dotnet\dl3\proset\win32  
The [Intel(R) PROSet - InstallShield Wizard] dialog starts.
4. Click [Next].
5. Choose "I accept the terms in the license agreement" and click [Next].
6. Click [Next].
7. Choose "I accept the terms in the license agreement" and click [Next].
8. Click [Install].
9. When [InstallShield Wizard Completed] window is displayed, click [Finished].
10. Remove the NEC EXPRESSBUILDER DVD from the optical disk drive, restart the system.

## Network Driver

Specify the details of network driver.

One standard network driver that is mounted will be installed automatically, but the link speed and Duplex mode need to be specified manually.

[When PROSet is not installed]

1. The [Local Area Connection Properties] dialog box appears.
  - \* The procedure in the case of the standard start menu
    1. Click Start menu, Click [Control Panel], Click [Network Connections], and Click [Local Area Connection].
  - \* The procedure in the case of the classic start menu
    1. Click Start menu, Click [Settings] and Click [Network Connections].  
The [Network Connections] dialog box appears.
    2. Right-click [Local Area Connection] and click [Properties] from pop-up menu.
2. Click [Configure].  
The property dialog box for network adapter appears.
3. Click the [Advanced] and specify the [Link Speed & Duplex] value the same as the value specified for HUB.
4. Click [OK] on the property dialog box for network adapter.

[When PROSet is installed]

1. The [Intel(R) PROSet] dialog box appears.
  - \* The procedure in the case of the standard start menu  
Click Start menu, point to [Control Panel], [administrative tools], and click [Computer Management] and then double click the [(Network Adapter Name)] in the Network Adapter list.
  - \* The procedure in the case of the classic start menu
    1. Click Start menu, point to [Settings] and click [Control Panel].
    2. Click [administrative tools].
    3. Click [Computer Management] and double click the [(Network Adapter Name)] in the Network Adapter list.
2. Click the [Link] and specify the [Speed and Duplex] value the same as the value specified for HUB.
3. Click [Apply] and click [OK].

Also, add or delete any protocols and services if necessary.

You can operate the process on the property dialog box for local area network which can be appeared from [Network and Dial-up Connection].

---

**NOTE:** We recommend you to add [Network Monitor] at [Adding Services]. [Network Monitor] can monitor the frame (or the packet) that the computer installing [Network Monitor] sends or receives. This tool is valuable when analyzing network trouble. For information on how to install the tool, see the "Setup for Trouble Process" later in this document.

---

---

## Re-install the Network Driver

The network driver will be installed automatically.

See Chapter 5, "Optional Network Board Driver" for re-install the optional network board driver.

---

## Adapter Fault Tolerance (AFT)/Adaptive Load Balancing (ALB)

See Chapter 5, "Adapter Fault Tolerance (AFT)/Adaptive Load Balancing (ALB)" for reset the Adapter Fault Tolerance (AFT)/Adaptive Load Balancing (ALB).

---

## Graphics Accelerator Driver

If you utilize standard graphics accelerator drivers, update your system with NEC EXPRESSBUILDER DVD attached to your system.

Standard graphics accelerator drivers will be installed automatically.

Please follow the following procedure when you want to re-install the driver individually.

1. Insert the NEC EXPRESSBUILDER DVD into the optical disk drive.  
If the autorun menu is displayed, close menu screen.
2. Click Start menu, point to [Programs], [Accessories] and click [Windows Explorer].
3. Run "setup.exe" in the following directory.  
\\006\win\winnt\dotnet\video\setup.exe
4. Follow the message to continue the installation.  
If the dialog message "Digital Signature could not been found." appears, select [Yes] to continue.
5. Remove the NEC EXPRESSBUILDER DVD from the optical disk drive, restart the system.

---

## Installing SCSI Controller Driver (N8103-75/95/107)

If you utilize SCSI controller driver (N8103-75/95/107), update your system with NEC EXPRESSBUILDER DVD attached to your system.

The SCSI controller driver will be installed automatically.

---

## About Windows Activation

Windows Server 2003 must be activated before you can use Windows Server 2003.

Windows activation process is as follows.

---

**NOTE:** When you use Windows Server 2003 R2, activation process is not needed.

---

1. Click [Run] on [Start] menu.  
Type as follows in the [Open:] box, and click [OK].  
oobe/msoobe /a

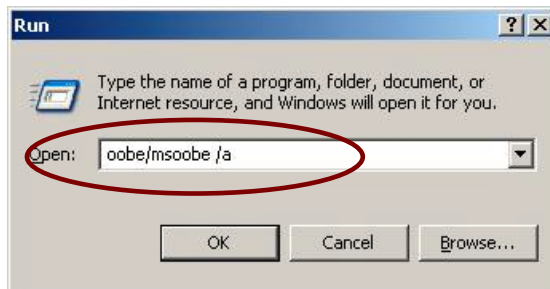

2. When the screen as follows is displayed, click [Next].

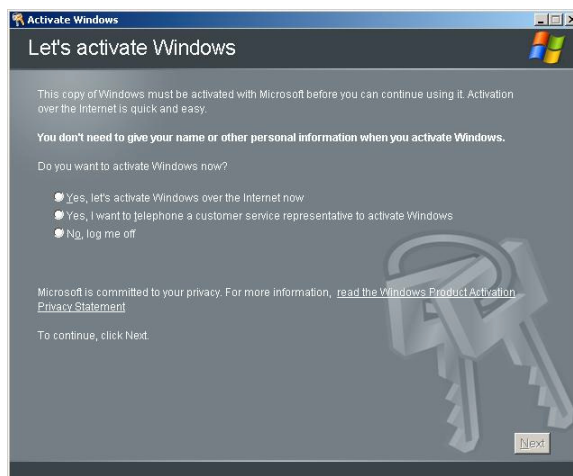

The following screen is displayed.



3. Process "Windows activation" according to the following message.



## SETTING FOR COLLECTING MEMORY DUMP (DEBUG INFORMATION)

Set for collecting memory dump using the procedure described in Chapter 5.

# Appendix F

---

## Using a Client Computer Which Has a CD Drive

The NEC EXPRESSBUILDER disk is DVD so that a client computer which you want to use for managing the server needs a DVD drive.

If you want to install the management software of EXPRESSBUILDER to the client without the DVD drive, make a CD-R from EXPRESSBUILDER DVD according to the following steps.

---

**NOTE:** This procedure can copy only one CD at the purpose of installing the management software to the client.

---

1. Insert the EXPRESSBUILDER DVD to the computer which has a DVD drive.
2. If Autorun menu appears, close the menu.
3. Copy the below files of EXPRESSBUILDER to a hard disk by using Explorer.

```
\(root folder)
|
| \006 : copy version.xml
|
| --- \ar_menu : copy this sub-folder
|
| --- \doc : copy this sub-folder
|
| --- \win : copy this sub-folder
```

4. Delete the ar\_menu\autorun\_menu.xml on the hard disk, and rename the ar\_menu\autorun\_en.xml on the hard disk to the autorun\_menu.xml.
5. Copy the above files/folders to a CD-R.  
Match the root folder when you burn a CD-R.
6. Delete the files/folders that you copied at step 3.
7. Insert the CD-R to a client computer which you want to install the management software.
8. Kick the below file of the CD-R by using Explorer.

```
\006\ar_menu\autorun_menu.exe (for Windows 32 bit edition)
autorun_menu_x64.exe (for Windows 64 bit edition)
```

(This page is intentionally left blank.)

# Appendix G

---

## Product Configuration Record Table

Use this table for information about setup and system environment change.

### Hardware

Main Unit						
	Model name		Serial No.		Date Installed	
CPU						
#1	Clock		Serial No.		Date Installed	
Memory						
#1	Size		Serial No.		Date Installed	
#2	Size		Serial No.		Date Installed	
#3	Size		Serial No.		Date Installed	
#4	Size		Serial No.		Date Installed	
Monitor						
	Type		Model name		Serial No.	
					Date Installed	
Hard Disk Drive						
Bay #1	Type			Serial No.		
	Capacity			Date Installed		
	Type number					
Bay #2	Type			Serial No.		
	Capacity			Date Installed		
	Type number					
Bay #3	Type			Serial No.		
	Capacity			Date Installed		
	Type number					
Bay #4	Type			Serial No.		
	Capacity			Date Installed		
	Type number					

G-2 Product Configuration Record Table

5.25-inch Device						
Slot 1	Size		Capacity		Serial No.	
	Model name		Type number		Date Installed	
Slot 2 (factory-installed optical disk drive)	Size		Capacity		Serial No.	
	Model name		Type number		Date Installed	
3.5-inch Device						
Slot 1 (1.44-MB floppy disk drive)	Size		Capacity		Serial No.	
	Model name		Type number		Date Installed	
Slot 2	Size		Capacity		Serial No.	
	Model name		Type number		Date Installed	
PCI Slot #1						
	Model name				Serial No.	
					Date Installed	
PCI Slot #2						
	Model name				Serial No.	
					Date Installed	
PCI Slot #3						
	Model name				Serial No.	
					Date Installed	
PCI Slot #4						
	Model name				Serial No.	
					Date Installed	
Printer						
	Model name				Serial No.	
	Manufacturer				Date Installed	
External Peripheral Device 1						
	Model name				Serial No.	
	Manufacturer				Date Installed	
External Peripheral Device 2						
	Model name				Serial No.	
	Manufacturer				Date Installed	
External Peripheral Device 3						
	Model name				Serial No.	
	Manufacturer				Date Installed	
External Peripheral Device 4						
	Model name				Serial No.	
	Manufacturer				Date Installed	



(This page is intentionally left blank.)