



**N8800-100F, EXP320B**

**NEC Express5800/320Fb-L**

**N8800-101F, EXP320A**

**NEC Express5800/320Fb-LR**

## **User's Guide**

1st Edition

1-2007

856-126408-102-00

## **PROPRIETARY NOTICE AND LIABILITY DISCLAIMER**

The information disclosed in this document, including all designs and related materials, is the valuable property of NEC Corporation (NEC) and /or its licensors. NEC and/or its licensors, as appropriate, reserve all patent, copyright and other proprietary rights to this document, including all design, manufacturing, reproduction, use, and sales rights thereto, except to the extent said rights are expressly granted to others.

The NEC product(s) discussed in this document are warranted in accordance with the terms of the Warranty Statement accompanying each product. However, actual performance of each such product is dependent upon factors such as system configuration, customer data, and operator control. Since implementation by customers of each product may vary, the suitability of specific product configurations and applications must be determined by the customer and is not warranted by NEC.

To allow for design and specification improvements, the information in this document is subject to change at any time, without notice. Reproduction of this document or portions thereof without prior written approval of NEC is prohibited.

First Printing, January 2007  
Copyright 2007  
NEC Corporation  
7-1 Shiba 5-Chome, Minato-Ku  
Tokyo 108-8001, Japan  
All Rights Reserved  
Printed in Japan



Keep this User's Guide handy for quick reference when necessary.

## SAFETY INDICATIONS



To use NEC Express5800 series safely, follow the instructions in this User's Guide.

This guide explains components that pose a danger, types of dangers, and actions taken to prevent them; such components are labeled warning.

This guide and warning labels use "WARNING" and "CAUTION" to indicate a danger depending on the degree. These terms are defined as follows:

 <b>WARNING</b>	Indicates a danger that could lead to a death or serious injury.
 <b>CAUTION</b>	Indicates a danger that could lead to a burn, other injuries or damage to physical assets.

This guide uses the following three types of symbols to give indications and precautions against a danger. They are defined as follows:





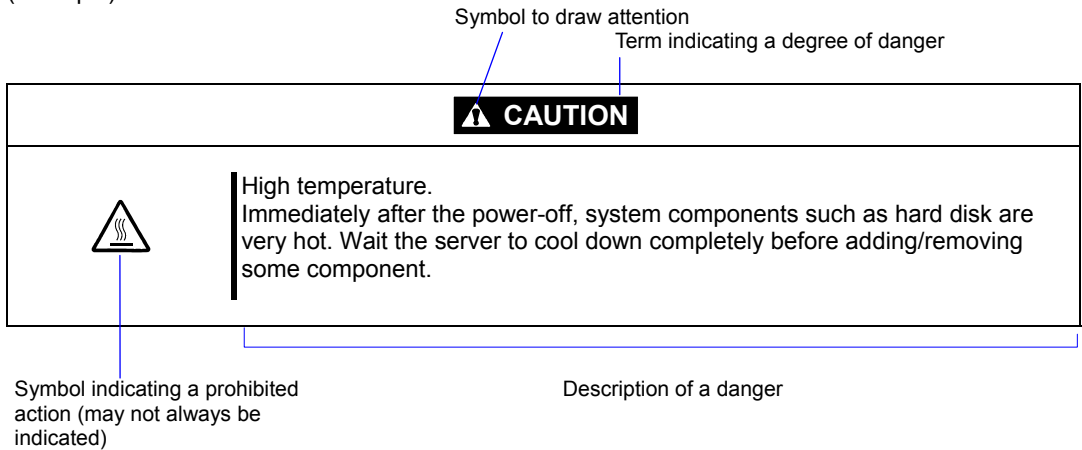



	Indicates that there is a risk of danger. Each image symbolizes a particular type of danger. (Attention)
	Indicates what you must not do. Each image symbolizes a particular type of prohibition. (Prohibited actions)
	Indicates what you must do. Each image symbolizes a particular type of action necessary to avoid a danger. (Mandatory actions)

(Example)









## SYMBOLS USED IN THIS USER'S GUIDE AND WARNING LABELS



### Attention

	Indicates a risk of an electric shock.
	Indicates a risk of a personal injury due to heat.
	Indicates a risk of catching your fingers.
	Indicates a risk of a fire or smoke.
	Indicates a general precaution or warning that is not defined herein.
	Indicates a risk of losing eyesight due to laser beam.
	Indicates a risk of an explosion.
	Indicates a risk of a personal injury.

### Prohibited actions

	Indicates a general prohibition that is not defined herein.
	Do not touch the indicated area. There is a risk of an electric shock or fire.
	Do not touch with wet hands. There is a risk of an electric shock.
	Keep from flame. There is a risk of a fire.
	Avoid using water or liquid nearby. If it spills on the equipment, there is a risk of an electric shock or fire.
	Do not disassemble, repair, or modify the equipment. There is a risk of an electric shock or fire.

## Mandatory actions

	Unplug the server. There is a risk of an electric shock or fire.
	Indicates a general action to take that is not defined herein. Make sure to follow the instructions.

**NOTE:** This equipment has been tested and found to comply with the limits for a Class A digital device, pursuant to Part 15 of the FCC Rules. These limits are designed to provide reasonable protection against harmful interference when the equipment is operated in a commercial environment. This equipment generates, uses, and can radiate radio frequency energy and, if not installed and used in accordance with the instruction manual, may cause harmful interference to radio communications. Operation of this equipment in a residential area is likely to cause harmful interference in which case the user will be required to correct the interference at his own expense.

警告使用者：

這是甲類的資訊產品，在居住的環境中使用時，可能會造成射頻干擾，在這種情況下，使用者會被要求採取某些適當的對策。

이 기기는 업무용으로 전자파적합등록을 한 기기이오니 판매자 또는 사용자는 이 점을 주의하시기 바라며 만약 잘못된 판매 또는 구입하였을 때에는 가정용으로 교환하시기 바랍니다.

This class A digital apparatus meets all requirements of the Canadian Interference-Causing Equipment Regulations.

Cet appareil numérique de la classe A respecte toutes les exigences du Règlement sur le matériel brouilleur du Canada.

### CE Statement

**Warning:** This is a Class A product. In residential environment, this product may cause radio interference, in which case the user may be required to take adequate measures (EN55022).

**CLASS 1  
LASER PRODUCT**

This system is classified as a CLASS 1 LASER PRODUCT. This label is located on the internal CD-ROM installed in your system.

**NOTE:** This product provides resistance against hardware faults with its redundant hardware modules. However, this does not mean complete fault-tolerance is assured. For example, there is a risk of system down when:

- A fatal fault occurs in software.
- Both modules within a redundant hardware pair break down.
- A fatal fault occurs in a non-redundant component, such as the clock generator circuitry or the interconnect backplane.
- The entire system is cut off from AC power.



## 安全注意事項

### 安全標示



請參考本用戶指南中的指示以安全使用NEC Express5800系列伺服器。

本用戶指南說明了設備何處有危險、危險類型、如何避免危險等。在設備可預計到的危險之處或其附近貼有警告標籤。

用戶指南及警告標籤中，根據危險程度不同，使用“警告”、“注意”等詞，含義如下：

 <b>WARNING</b>	表示如不遵守該指示，可能引發人員傷亡。
 <b>CAUTION</b>	表示如不遵守該指示，可能發生燒傷等身體損傷或造成物質損失。

對危險的提示表示有如下三種符號，具體含義如下所述：

	表示該處可能發生危險。符號為危險內容的圖案。（注意）
	表示禁止行爲。符號中或其附近的圖案為禁止行爲內容。（禁止行爲）
	表示強制行爲。符號中的圖案為強制必須做的行爲內容。即為避免危險必需的行爲。（強制行爲）

（用戶指南中範例）

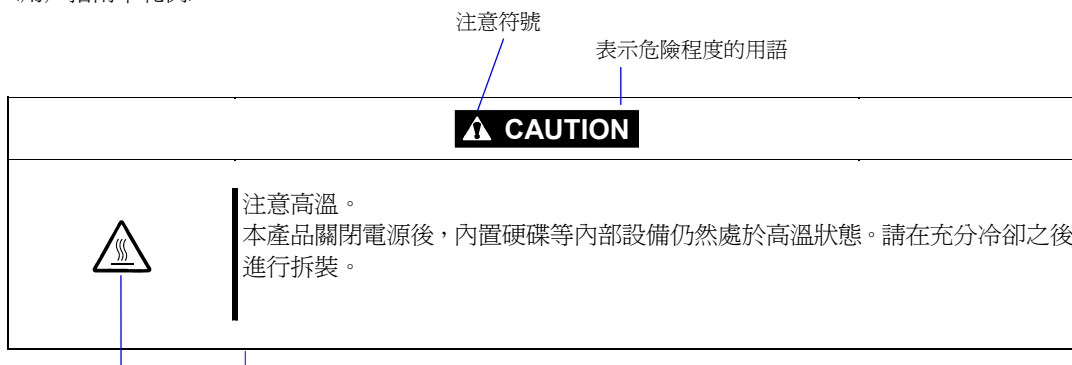









禁止行爲的提示符號（有可能沒有此類提示）







危險提示內容

## 本書及警告標籤中使用的符號

### 注意



	表示有觸電的危險。
	表示有因高溫而負傷的危險。
	表示有手指等被夾住的危險。
	表示有冒煙或者著火的危險。
	表示非特定的一般的提醒警告。
	表示有因雷射導致失明的危險。
	表示有爆炸的危險。
	表示有受傷的危險。

### 禁止行爲

	表示非特定的一般禁止。
	不要觸摸指定區域。有觸電或著火的危險。
	不要用濕手觸摸。有觸電的危險。
	遠離火源。有著火的危險。
	遠離液體。如果沾到液體，有觸電或著火的危險。
	請不要對本設備進行拆卸、修理、改造。有觸電和發生火災的危險。



## 強制行爲

	請將本設備的電源插頭從伺服器上拔下。有發生火災和觸電的危險。
	對非特定的一般使用者的行爲進行指示。請按照說明進行操作。

**NOTE:** This equipment has been tested and found to comply with the limits for a Class A digital device, pursuant to Part 15 of the FCC Rules. These limits are designed to provide reasonable protection against harmful interference when the equipment is operated in a commercial environment. This equipment generates, uses, and can radiate radio frequency energy and, if not installed and used in accordance with the instruction manual, may cause harmful interference to radio communications. Operation of this equipment in a residential area is likely to cause harmful interference in which case the user will be required to correct the interference at his own expense.

### 警告使用者：

這是甲類的資訊產品，在居住的環境中使用時，可能會造成射頻干擾，在這種情況下，使用者會被要求採取某些適當的對策。

**CLASS 1  
LASER PRODUCT**

這是CLASS 1 LASER PRODUCT。該標籤貼於系統的內部光碟。

注意：本產品通過多餘的硬體模組提供硬體容錯性能。但是這並不表示能夠保證完全容錯。

如，在以下情況下可能發生宕機：

- 軟體發生致命故障。
- 多餘硬體雙方均發生故障，不能運行。
- 時鐘產生器線路或內部連接背板等非多餘元件發生致命故障。
- 切斷了整個系統的AC電源

## Trademarks and Patents

NEC EXPRESSBUILDER and NEC ESMPRO are trademarks of NEC Corporation.

Microsoft, and Windows are registered trademarks of Microsoft Corporation in the United States and other countries.

Avocent and Dambrackas Video Compression (DVC) are trademarks or registered trademarks of Avocent Corporation in the United States and other countries.

Mozilla is a trademark of Mozilla Foundation.

Netscape is a trademark or registered trademark of Netscape Communications Corporation in the United States and other countries. Java is a trademark or registered trademark of Sun Microsystems, Inc. in the United States and other countries.

Linux is a registered trademark of Linux Torvalds. Red Hat and RPM are trademarks or registered trademarks of Red Hat, Inc. in the United States and other countries.

All other product, brand, or trade names used in this publication are the trademarks or registered trademarks of their respective trademark owners.

The Dambrackas Video Compression algorithm from Avocent Corporation is used for ft Remote Management Card.

U.S. Patent Numbers: 5,732,212, 5,937,176, 6,633,905, 6,681,250, 6,701,380 and other patents pending

Taiwanese Patent Number: 173784

European Patent Number: 0 740 811

Microsoft Windows Server 2003 Standard Edition operating system and Microsoft Windows Server 2003 Enterprise Edition operating system are called Windows Server for short. Microsoft Windows 2000 Server operating system, Microsoft Windows 2000 Advanced Server operating system and Microsoft Windows 2000 Professional operating system are called Windows 2000 for short. Microsoft Windows NT Server network operating system version 3.51/4.0 and Microsoft Windows NT Workstation operating system version 3.51/4.0 are called Windows NT for short. Microsoft Windows Millennium Edition Operating System is called Windows Me for short. Microsoft Windows 98 operating system is called Windows 98 for short. Microsoft Windows 95 operating system is called Windows 95 for short.

Names used with sample applications are all fictitious. They are unrelated to any existing product names, names of organizations, or individual names.

Most of the software used for this server can be redistributed free under the terms of the BSD Copyright and the GNU Public License. However, there is software that requires permissions for redistribution as the owners have the ownership. For details, see "Introduction" in the attachment.

### **To prevent voltage sag:**

This product may be affected by voltage sag caused due to lightning. To prevent voltage sag, you are recommended to use an AC uninterruptible power supply (UPS) unit.

**Notes:**

- (1) No part of this manual may be reproduced in any form without prior written permission of NEC Corporation.
- (2) The contents of this manual are subject to change without prior notice.
- (3) The contents of this manual shall not be copied or altered without prior written permission of NEC Corporation.
- (4) All efforts have been made to ensure the accuracy of all information in this manual. If you find any part unclear, incorrect, or omitted in this manual, contact the sales agent where you purchased this product.
- (5) NEC assumes no liability arising from the use of this product, nor any liability for incidental or consequential damage arising from the use of this manual regardless of (4) above.

**PREFACE**

Welcome to the NEC Express5800/ft series.

NEC Express5800/ft series is a “fault-tolerant (ft)” server focusing on “high reliability” in terms of fault-tolerance, in addition to “high performance,” “scalability,” and “general versatility” provided by NEC Express5800 series. In the event of trouble, its dual configuration will allow the system to instantaneously isolate the failed parts to assure non-stop running; operation will be moved smoothly from one module to the other, minimizing damage to it. You can use this NEC Express5800/ft series in a mission-critical system where high availability is required. By the use of Linux operating system, it also provides outstanding openness for general-purpose applications, etc.

To make the best use of these features, read this User's Guide thoroughly to understand how to operate NEC Express5800/ft series.

## ABOUT THIS USER'S GUIDE

This User's Guide helps a user to properly setup and use the product.

Consult this guide to ensure safety as well as to cope with trouble during a system setup and daily operation.

Keep this manual handy.

This User's Guide is intended for users who have a good knowledge on the basic use of Linux operating systems and general I/O devices such as a keyboard and mouse.

### How to Use This User's Guide

This guide consists of eight chapters and appendices. To help you find a solution quickly, the guide contains the following information:

For descriptions on setting up this product, see the separate volume "User's Guide (Setup)."

Read "Precautions for Use" first.

Before going on to main chapters, be sure to read "Precautions for Use." These precautions are very important for using the product safely.

#### **Chapter 1 Precautions for Use**

This chapter describes precautions necessary to use the product safely and properly. Be sure to read this chapter before using the product. It also provides information on user support. It will be helpful when you need maintenance service, support, etc.

#### **Chapter 2 General Description**

This chapter describes what you should know about the product: its component names, functions, operating procedures as well as handling of devices and other parts.

#### **Chapter 3 Linux Setup and Operation**

This chapter describes setup and operation specific to the product when it is on Linux.

#### **Chapter 4 System Configuration**

This chapter describes how to make settings of built-in basic input/output system. It also describes factory-shipped parameters.

#### **Chapter 5 Installing and Using Utilities**

This chapter describes features and operating procedures of a standard utility "NEC EXPRESSBUILDER." It also describes procedures to install and operate various software programs contained in its CD-ROM.

#### **Chapter 6 Maintenance**

This chapter describes maintenance procedures and use of maintenance tools. If you need to move the product for maintenance purposes, follow the steps provided in this chapter.

#### **Chapter 7 Troubleshooting**

If the product does not work properly, see this chapter before deciding that it is a breakdown.

#### **Chapter 8 System Upgrade**

This chapter describes procedures to add options and precautions. See also this chapter when you replace failed components.

#### **Appendix A Specifications**

This appendix lists specifications of the product.

#### **Appendix B I/O Port Addresses**

This appendix lists factory-assigned I/O port addresses.

## Additional symbols

The following symbols are used throughout this User's Guide in addition to the caution symbols described at the beginning.

<b>IMPORTANT:</b>	Important points or instructions to keep in mind when using the server or software
<b>CHECK:</b>	Something you need to make sure when using the server of software
<b>TIPS:</b>	Helpful information, something useful to know

## Accessories

This product is shipped with various accessories. See the attached list to make sure everything is included and check the individual items. If some component is missing or damaged, contact your sales agent.

- Keep the accessories in a safe place. You will need them when you perform setup, addition of options, or replacement of failed components.
- To check NEC EXPRESSBUILDER components, see the attached list.
- Be sure to fill out and mail the software registration card that is attached to your operating system.
- Make backup copies of included floppy disks, if any. Keep the original disks as the master disks; use these copies in operation.
- Improper use of an included floppy disk or CD-ROM may alter your system environment. If you find something unclear, stop using them and contact your sales agent.

## CONTENTS

PREFACE .....	i
ABOUT THIS USER'S GUIDE.....	ii
<b>Chapter 1 Precautions for Use.....</b>	<b>1-1</b>
WARNING LABELS.....	1-2
Server Chassis .....	1-2
CPU/IO modules .....	1-3
CPU/IO modules .....	1-4
PRECAUTIONS FOR SAFETY .....	1-5
General .....	1-5
Use of Power Supply and Power Cord .....	1-6
Installation, Relocation, Storage and Connection .....	1-7
Cleaning and Handling of Internal Devices.....	1-9
During Operation.....	1-10
Rack-mount Model.....	1-11
For Proper Operation .....	1-12
安全注意事項 .....	1-14
一般注意事項 .....	1-14
使用電源及電源線注意事項 .....	1-15
安裝，移動，保管及連接注意事項 .....	1-16
整理及操作內部設備時的注意事項 .....	1-17
操作注意事項 .....	1-18
機架式伺服器的注意事項 .....	1-19
DISPOSAL OF EQUIPMENT AND CONSUMABLES.....	1-21
IF SYSTEM TROUBLE IS SUSPECTED .....	1-22
ABOUT REPAIR PARTS .....	1-22
ABOUT OUR WEB SERVICE.....	1-22
<b>Chapter 2 General Description .....</b>	<b>2-1</b>
STANDARD FEATURES .....	2-2
NAMES AND FUNCTIONS OF COMPONENTS.....	2-6
Front View (inside).....	2-7
CD- ROM Drive.....	2-14
Rear View .....	2-15
CPU/IO Module.....	2-18
ft Remote Management Card.....	2-21
LEDs.....	2-22
BASIC OPERATION.....	2-28
Security lock (front door lock) (for tower model) .....	2-28
Installing/Removing the Front Bezel.....	2-29
Power ON .....	2-30
Power OFF .....	2-31
POST Check.....	2-31
Floppy Disk Drive (Option) .....	2-34
CD-ROM Drive.....	2-36

<b>Chapter 3 Linux Setup and Operation .....</b>	<b>3-1</b>
HARD DISK CONFIGURATIONS THAT CAN BE BUILT ON THE NEC Express5800/ft series .....	3-2
REPLACING 3.5-INCH HARD DISK DRIVE .....	3-3
How to Locate Failed Disks .....	3-3
Restoring Redundant Configuration Manually .....	3-5
SETTING THE VIDEO MODE .....	3-10
Notes .....	3-11
DUMP INITIALIZATION .....	3-12
KEYBOARD SETTINGS FOR X WINDOW SYSTEM .....	3-14
ACCESSING USB FDD .....	3-16
Notes .....	3-16
<b>Chapter 4 System Configuration .....</b>	<b>4-1</b>
SYSTEM BIOS ~ SETUP ~ .....	4-2
Starting SETUP Utility .....	4-3
Description of On-Screen Items and Key Usage .....	4-4
Configuration Examples .....	4-6
Menu and Parameter Descriptions .....	4-9
SCSI BIOS (SCSISelect) .....	4-30
FORCED SHUTDOWN AND CLEAR .....	4-37
Forced Shutdown .....	4-37
Clear CMOS/Password .....	4-38
How to Clear Passwords .....	4-41
Remote Management function .....	4-44
Network Default Values .....	4-44
Settings on the Server .....	4-44
Initial Settings on the Server .....	4-45
Setting a Management PC .....	4-46
Using Remote Management .....	4-48
Troubleshooting .....	4-79
<b>Chapter 5 Installing and Using Utilities .....</b>	<b>5-1</b>
NEC EXPRESSBUILDER .....	5-2
Start Menu .....	5-2
NEC EXPRESSBUILDER Top Menu .....	5-4
Master Control Menu .....	5-7
NEC ESMPRO Agent and Manager .....	5-8
Overview .....	5-8
NEC ESMPRO Agent .....	5-16
Server Maintenance Utility .....	5-40
Maintenance of NEC Express5800/ft series .....	5-48
Notes .....	5-74
<b>Chapter 6 Maintenance .....</b>	<b>6-1</b>
DAILY MAINTENANCE .....	6-2
Checking Alert .....	6-2
Checking STATUS LEDs .....	6-2

---

Making Backup Copies .....	6-3
Cleaning.....	6-3
SYSTEM DIAGNOSTICS .....	6-7
Test Items.....	6-7
Startup and Exit of System Diagnostics .....	6-7
OFF-LINE MAINTENANCE UTILITY .....	6-11
Starting the Off-line Maintenance Utility .....	6-11
Features of Off-line Maintenance Utility.....	6-11
RELOCATING/STORING THE NEC Express5800/ft series.....	6-13
<b>Chapter 7 Troubleshooting .....</b>	<b>7-1</b>
TO LOCATE THE ERRORS.....	7-2
ERROR MESSAGES .....	7-3
Error Messages by LED Indication .....	7-3
POST Error Messages .....	7-4
Error Notification by BEEP.....	7-12
Linux Error Messages.....	7-13
Server Management Application Error Message .....	7-22
SOLVING PROBLEMS .....	7-23
Problems with NEC Express5800/ft series.....	7-23
Event Log.....	7-31
Syslog.....	7-32
Problems with NEC EXPRESSBUILDER.....	7-35
Problems with NEC ESMPRO .....	7-36
COLLECTION OF TROUBLE LOGS.....	7-37
Collection of syslog.....	7-37
Collection of System Information .....	7-37
Collection of the Memory Dump.....	7-38
Backup of IPMI Information.....	7-39
<b>Chapter 8 System Upgrade .....</b>	<b>8-1</b>
SAFETY PRECAUTIONS .....	8-2
ANTI-STATIC MEASURES .....	8-3
PREPARING YOUR SYSTEM FOR UPGRADE .....	8-4
3.5-INCH HARD DISK DRIVE.....	8-5
Installing 3.5-inch Hard Disk Drive .....	8-6
Removing 3.5-inch Hard Disk Drive.....	8-8
Replacing 3.5-inch Hard Disk Drive .....	8-9
RAID CONFIGURATION WHEN DISKS ARE ADDED.....	8-10
5.25-inch device.....	8-13
Installing 5.25-inch Device.....	8-14
Removing 5.25-inch Device .....	8-15
CPU/IO Module.....	8-16
Precautions .....	8-16
Removing CPU/IO Module.....	8-17
Installing CPU/IO Module.....	8-19
DIMM.....	8-20
Precautions .....	8-21
Installing DIMM.....	8-22



---

Removing DIMM.....	8-23
Replacing DIMM .....	8-24
PROCESSOR (CPU).....	8-25
Installing CPU (Model with Air-cooling Kit).....	8-26
Removing CPU (Model with Heat Sink).....	8-29
Replacing CPU.....	8-30
ft Remote Management Card.....	8-31
Installing ft Remote Management Card .....	8-32
Removing ft Remote Management Card.....	8-33
PCI BOARD.....	8-34
Installing PCI Board.....	8-36
Removing PCI Board .....	8-37
Replacing PCI Board.....	8-38
Setup of Optional PCI Board.....	8-39
<b>Appendix A Specifications.....</b>	<b>A-1</b>
<b>Appendix B I/O Port Addresses.....</b>	<b>B-1</b>

(This page is intentionally left blank.)

# Chapter 1

---

## Precautions for Use

This chapter includes information necessary for proper and safe operation of the server.

## WARNING LABELS

Warning labels are placed in certain parts of the system so that the user stays alert to possible risks (Do not remove or damage these labels).

If some label is missing, about to peel off, or illegible, contact your sales agent.

### Server Chassis

Tower model

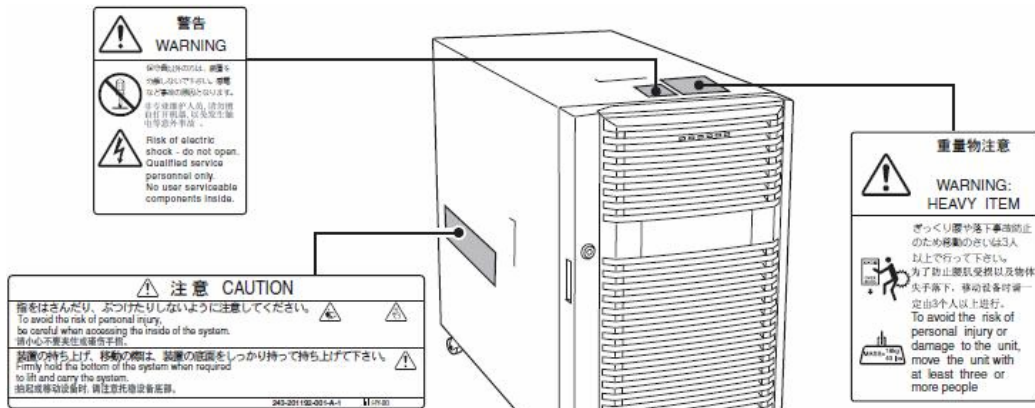

Front

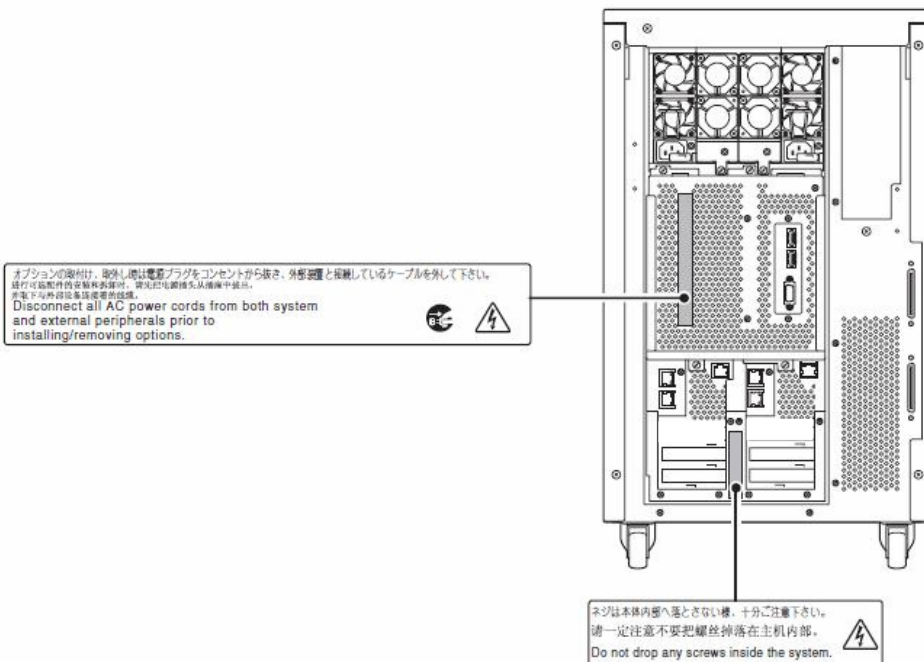

Rear

Rack model

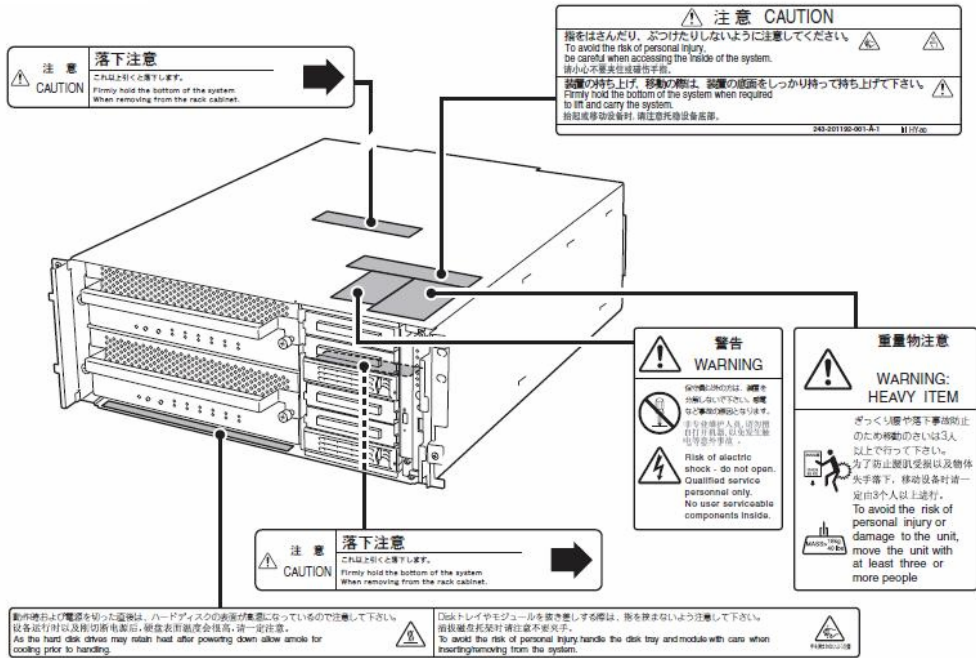

Front

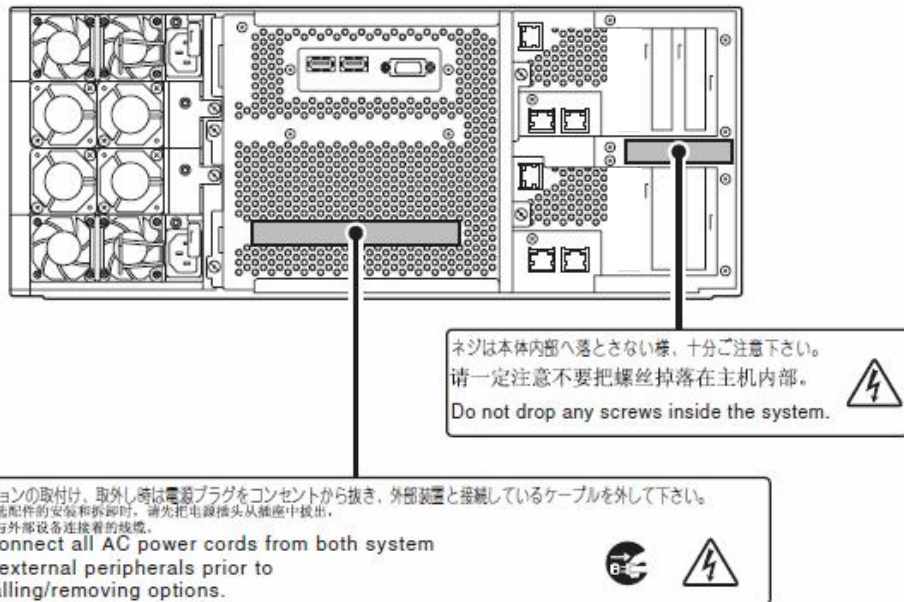

Rear

## CPU/IO modules

The following shows the place on CPU/IO modules where the label is attached.

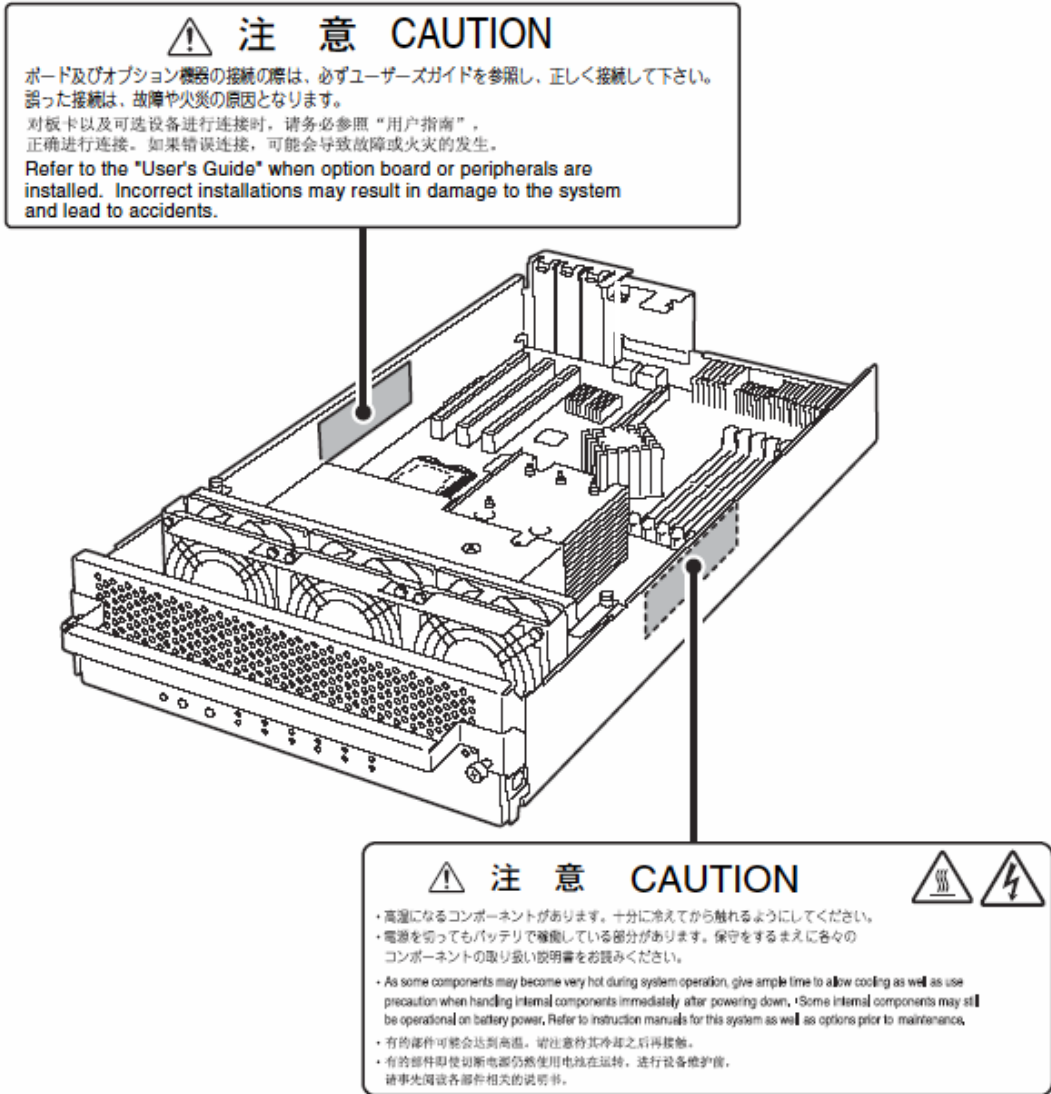

## PRECAUTIONS FOR SAFETY

This section provides precautions for using the server safely. Read this section carefully to ensure proper and safe use of the server. For symbol meanings, see "SAFETY INDICATIONS" described in the previous section.

### General

#### WARNING



Do not use the equipment in an operation where human lives are involved or high reliability is required.

This equipment is not intended for use in controlling or use with facilities or systems where human lives are involved or high reliability is required, including medical devices or nuclear, aerospace, transportation, and traffic control facilities. NEC assumes no liability for any accidents or damage to physical assets resulting from the use of this equipment in such systems or facilities.



Do not continue to use the equipment if you detect smoke, odor, or noise.

If the equipment emits smoke, odor, or noise, immediately flip off the POWER switch, unplug the cord, and contact your sales agent. There is a risk of a fire.



Do not insert a wire or metal object

Do not insert a wire or metal objects into a vent or disk drive slot. There is a risk of an electric shock.



Do not use the equipment in an unsuitable place.

Do not install a server rack in an unsuitable environment.

Other systems also may be affected, and the rack may fall over to cause a fire or injuries. For details about installation environment and quake-resistant engineering, see the attached manual or contact your sales agent.

#### CAUTION



Prevent water or foreign objects from getting into the equipment.



Do not let water or foreign objects (e.g., pins or paper clips) enter the equipment. There is a risk of a fire, electric shock, and breakdown. When such things accidentally enter the equipment, immediately turn off the power and unplug the cord. Contact your sales agent instead of trying to disassemble it yourself.

## Use of Power Supply and Power Cord

### **WARNING**



Do not handle a power plug with a wet hand.

Do not plug/unplug a power cord with a wet hand. There is a risk of an electric shock.



Do not connect the ground wire to a gas pipe.

Never connect the ground wire to a gas pipe. There is a risk of a gas explosion.

### **CAUTION**



Do not plug the attached cord in a nonconforming outlet.

Use a wall outlet with specified voltage and power type. There is a risk of a fire or current leakage.



Avoid installing the equipment where you may need an extension cord. If the cord that does not meet the power specifications, there is a risk of overheating that could lead to a fire.



Do not plug too many cords in a single outlet.

If the rated current is exceeded, there is a risk of overheating that could lead to a fire.



Do not plug the cord insecurely.

Insert the plug firmly into an outlet. There is a risk of heat or fire due to poor contact. If dust settles on the slots and it absorbs moisture, there is also a risk of heat or fire.



Do not use nonconforming power cords.



AC cord is to spend the thing of the next specifications.

Maximum 4.5m (14.76 ft) long. Rated minimum 125V, 10A, Type SJT flexible cord.

You also have to observe the following prohibitions about handling and connecting interface cables.

- Do not pull on the cord.
- Do not pinch the cord.
- Do not bend the cord.
- Keep chemicals away from the cord.
- Do not twist the cord.
- Do not tread on the cord.
- Do not place any object on the cord.
- Do not use cords as bundled.
- Do not alter, modify, or repair the cord.
- Do not staple the cord.
- Do not use any damaged cord. (Replace it with a new one of the same specifications. For replacement procedures, contact your sales agent.)



---

## Installation, Relocation, Storage and Connection

### WARNING



Disconnect the power cord(s) before installing or removing the equipment.

Be sure to power off the equipment and unplug its power cords from the wall outlet before installation/relocation. All voltage is removed only when the power cords are unplugged.

### CAUTION



Do not install or store the equipment in an unsuitable place.

Install or store the equipment in such a place as specified in this User's Guide. Avoid the following, or there is a risk of a fire.

- a dusty place
- a humid place located near a boiler, etc
- a place exposed to direct sunlight
- an unstable place



Be careful not to hurt your fingers.

Exercise great care not to hurt your fingers on the rail when you mount/dismount the equipment into/from the rack.



Do not use or store this product in corrosive environment.

Avoid the usage or storage of this product in an environment which may be exposed to corrosive gases, such as those including but not limited to : sulfur dioxide, hydrogen sulfide, nitrogen dioxide, chlorine, ammonia and/or ozone.

Avoid installing this product in a dusty environment or one that may be exposed to corrosive materials such as sodium chloride and/or sulfur.

Avoid installing this product in an environment which may have excessive metal flakes or conductive particles in the air.

Such environments may cause corrosion or short circuits within this product, resulting in not only damage to this product, but may even lead to be a fire hazard.

If there are any concerns regarding the environment at the planned site of installation or storage, please contact your sales agent.

 **CAUTION**



Do not connect any interface cable with the power cord of the server plugged to a power source.



Make sure to power off the server and unplug the power cord from a power outlet before installing/removing any optional internal device or connecting/disconnecting any interface cable to/from the server. If the server is off-powered but its power cord is plugged to a power source, touching an internal device, cable, or connector may cause an electric shock or a fire resulted from a short circuit.



Do not use any non-designated interface cable.

Use only interface cables designated by NEC; identify which component or connector to attach beforehand. If you use a wrong cable or make a wrong connection, there is a risk of short-circuit that could lead to a fire.

You also have to observe the following prohibitions about handling and connecting interface cables:

- Do not use any damaged cable connector.
- Do not step on the cable.
- Do not place any object on the cable.
- Do not use the equipment with loose cable connections.
- Do not use any damaged cable.

## Cleaning and Handling of Internal Devices

### ⚠ WARNING



Do not disassemble, repair, or alter the server.



Unless described herein, never attempt to disassemble, repair, or alter the equipment. There is a risk of an electric shock or fire as well as malfunction.



Do not look into the CD-ROM drive.



The CD-ROM drive uses a laser beam. Do not look or insert a mirror inside while the system is on. A laser beam is invisible; if your eyes get exposed to it, there is a risk of losing eyesight.



Do not detach a lithium battery yourself.

This equipment has a lithium battery. Do not detach it yourself. If the battery is exposed to fire or water, it could explode.

When the lithium battery is running down and the equipment does not work correctly, contact your sales agent instead of disassembling, replacing or recharging it yourself.

**RISK OF EXPLOSION IF BATTERY IS REPLACED WITH INCORRECT TYPE.  
DISPOSE OF USED BATTERIES ACCORDING TO THE INSTRUCTION.**



Disconnect the power plug before cleaning the server.

Make sure to power off the server and disconnect the power plug from a power outlet before cleaning or installing/removing internal optional devices. Touching any internal device of the server with its power cord connected to a power source may cause an electric shock even if the server is off-powered.

Disconnect the power plug from the outlet occasionally and clean the plug with a dry cloth. Heat will be generated if condensation is formed on a dusty plug, which may cause a fire.

### ⚠ CAUTION



High temperature

Immediately after powering off the system, system components such as hard disk may be very hot. Wait for the server to cool down completely before adding/removing components.



Make sure to complete installation.

Firmly install all power cords, interface cables and/or boards. An incompletely installed component may cause a contact failure, resulting in fire and/or smoke.

**⚠ CAUTION**



Protect the unused connectors with the protective cap.

The unused power cord connectors are covered with the protective cap to prevent short circuits and electrical hazards. When removing the power cord connector from the internal devices, attach the protective cap to the connector. Failure to follow this warning may cause a fire or an electric shock.

---

## During Operation

**⚠ CAUTION**



Do not pull out a device during operation.

Do not pull out or remove a device while it works. There is a risk of malfunction and injuries.



Do not touch the equipment when it thunders.

Unplug the equipment when it threatens to thunder. If it starts to thunder before you unplug the equipment, do not touch the equipment and cables. There is a risk of a fire or electric shock.



Keep animals away.



Animal's waste or hair may get inside the equipment to cause a fire or electric shock.



Do not place any object on top of the server.

The object may fall off to cause injuries, damage to hardware and/or a fire.



Do not leave the CD tray ejected.

Dust may get in the equipment to cause malfunction. The ejected tray may also become a cause of injuries.



Do not use a cellular phone or pager around the equipment.

Turn off your cellular phone or pager when you use the equipment. Their radio waves may cause the equipment to malfunction.

---

## Rack-mount Model

**⚠ CAUTION**

Do not install the equipment on a nonconforming rack.

Install the equipment on a 19-inch rack conforming to the EIA standard. Do not use the equipment without a rack or install it on a nonconforming rack. The equipment may not function properly, and there is a risk of damage to physical assets or injuries. For suitable racks, contact your sales agent.



Do not attempt to install the server yourself.

To avoid a risk of injuries, users should not attempt to install the equipment into a rack. Installation should be performed by trained maintenance personnel.

**< For Maintenance Personnel Only >**



Do not install the equipment in such a manner that its weight is imposed on a single place.

To distribute the weight, attach stabilizers or install two or more racks. It may fall down to cause injuries.



Do not assemble parts alone.

It takes at least two people to mount doors and trays to a rack. You may drop some parts to cause a breakage or injuries.



Do not pull a device out of the rack if it is unstable.

Before pulling out a device, make sure that the rack is fixed (by stabilizers or quake-resistant engineering).



Do not leave two or more devices pulled out from the rack.

If you pull out two or more devices the rack may fall down. You can only pull out one device at a time.



Do not install excessive wiring.

To prevent burns, fires, and damage to the equipment, make sure that the rated load of the power branch circuit is not exceeded. For more information on installation and wiring of power-related facilities, contact your electrician or local power company.

---

## For Proper Operation

Observe the following instructions for successful operation of the server. Failure to observe them could lead to malfunction or breakdown.

- Perform installation in a place where the system can operate correctly. For details, see the separate volume "User's Guide (Setup)."
- Before turning off the power or ejecting a disk, make sure that the access LED is off.
- When you have just turned off the power, wait at least 30 seconds before turning it on again.
- Once you have turned on the server, do not turn it off until the "NEC" logo appears on the screen.
- Plug the attached cord in the outlet whose AC input voltage is 100V.
- After plugging in the power cord, do not turn on the power of the equipment for 30 seconds.
- Before you move the equipment, turn off the power and unplug the cord.
- This server shall not assure reproduction of copy-protect CDs using reproduction equipment if such disks do not comply with CD standards.
- Clean the equipment regularly. (For procedures, see Chapter 6.) Regular cleaning is effective in preventing various types of trouble.
- Lightning may cause voltage sag. As a preventive measure, it is recommended to use UPS (uninterruptible power supply).

This equipment does not support the connection through an UPS serial port (RS-232C) or the control using PowerChutePlus.

- Check and adjust the system clock before operation in the following conditions:
  - After transporting the equipment
  - After storing the equipment
  - After the equipment halt under the conditions which is out of the guaranteed environment conditions (Temperature: 10 to 35°C, Humidity: 20 to 80%).

Check the system clock once in a month. It is recommended to operate the system clock using a time server (NTP server) if it is installed on the system which requires high level of time accuracy. If the system clock goes out of alignment remarkably as time goes by, though the system clock adjustment is performed, contact your sales agent.

- When you store the equipment, keep it under storage environment conditions (Temperature: -10 to 55°C, Humidity: 20 to 80%, non-condensing).
- If NEC Express5800/ft series, the built-in optional devices, and the media set for the backup devices (tape cartridges) are moved from a cold place to a warm place in a short time, condensation will occur and cause malfunctions and breakdown when these are used in such state. In order to protect important stored data and assets, make sure to wait for a sufficient period of time to use the server or components in the operating environment.

Reference: Length of the time effective at avoiding condensation in winter (more than 10°C differences between room temperature and atmospheric temperature)

Disk devices: Approximately 2-3 hours

Tape media: Approximately 1 day

- Make sure that the optional devices are attachable and connectable to the equipment. There is a risk of malfunctions that could lead to a breakdown of the equipment even if you could attach and connect.
- Make sure that your options are compatible with the system. If you attach any incompatible option, there is a risk of malfunction that could lead to a breakdown.
- It is recommended to use NEC's genuine option products. Some competitors' products are compatible with this server. However, servicing for trouble or damage resulting from such a product will be charged even within the warranty period.

## 安全注意事項

本節講述安全使用本伺服器所需的注意事項。爲了您正確安全地使用本伺服器，請仔細閱讀該節內容。符號的相關說明請參考“安全標示（SAFETY INDICATIONS）”說明。

### 一般注意事項

#### WARNING



不要用於危及人命和需要高度可靠性的操作。

本產品不要安裝在醫療設備、原子能設備、航空宇宙機器、運輸設備等會危及人命以及需要高度可靠性的設備和機器上，也不要使用本產品來控制這些機器。如果將本產品用於這類系統的設備及機器，造成人身事故及財產損失等後果，本公司概不負責。



發生冒煙、異味、雜音時不要使用。

發生冒煙、異味、雜音等時，請直接關閉電源POWER，並將電源插頭從插座上拔下。然後請與經銷商或維護服務公司聯繫。繼續使用會導致火災。



不要插入鐵絲和金屬片。

不要將金屬片和鐵絲等異物插入通氣孔或軟碟機、光碟機的縫隙。有觸電的危險。

#### CAUTION



設備內不要進水和異物。



設備內不要進入水、針、夾子等異物。有可能導致火災和觸電。一旦進入異物，請立即關閉電源，將電源插頭從插座上拔下來。不要自行拆卸，請與經銷商或維護服務公司聯繫。



## 使用電源及電源線注意事項

### ⚠ WARNING



不要用濕手拿電源插頭。

不要用濕手插拔電源插頭。有觸電的危險。



不要把地線連接到煤氣管道上。



請勿將地線連接到煤氣管道上。有導致煤氣爆炸的危險。

### ⚠ CAUTION



不要插入未指定的插座。

電源請使用指定電壓及電源的壁式插座。使用未指定的電源會造成火災和漏電。請避免使用延長線安裝設備。如果連接與本產品電源規格不相符的電線，會因過熱而導致火災。



不要在一個插座上插接多個電源線。

插座如果超過額定電流，會因過熱而導致火災的危險。



不要只插入一半。

請將電源插頭直插到底部。如果插入一半會因接觸不良而發熱，造成火災。另外，插入部如附著灰塵、水滴等，會因發熱導致火災。



不要使用未指定的電源線。

請使用下列規格的AC電源線。  
最長4.5m (14.76 ft)，最小額定電壓125V，10A，SJT電源線。  
此外，操作和連接電源線時請遵循以下注意事項。

- 不要拖拽電源線。
- 不要夾電源線
- 不要彎折電源線。
- 不要使電源線靠近化學藥品。
- 不要扭曲電源線。
- 不要踩踏電源線。
- 不要在電源線上載入物品。
- 不要捆綁電源線。
- 不要對電源線進行改造、加工、修復。
- 不要用固定器等固定電源線。
- 不要使用損傷的電源線。（損傷的電源線要立即更換為相同規格的電源線。更換事宜請與經銷商或維護服務公司聯繫）



## 安裝，移動，保管及連接注意事項

### ⚠ CAUTION



不要安裝或存放在未指定的場所。

不要將本設備放置在如下場所和本書未指定的場所，有導致火災的危險。

- 灰塵較多的場所
- 熱水器旁等濕氣較高的場所
- 陽光直射的場所
- 不平穩的場所



不要在腐蝕性環境中使用或存放設備。

不要在有腐蝕性氣體（如二氧化硫、氫化硫、氮、氫、氨或臭氧等）的環境中使用或存放本產品。

不要將本產品安裝在灰塵較多或含有腐蝕性物質如氯化鈉或硫磺等的地方。

不要將本產品安裝在空氣中含有過量金屬碎末或傳導粒子的地方。

上述環境可能導致本產品腐蝕或短路，因而損壞產品，甚至引起火災。

對產品安裝或存放環境有任何疑問，請與經銷商或維修服務公司聯繫。



不要使用未指定的信號線。

使用NEC指定的信號線，並在確認連接設備和介面後進行連接。使用未指定信號線或連接錯誤等會造成短路、導致火災。

信號線的操作和連接，須遵守以下注意事項：

- 不要使用任何損壞的信號線接頭。
- 不要踩踏信號線。
- 不要在信號線上載入物品。
- 信號線接鬆動時不要使用。
- 不要使用任何損壞的信號線。

## 整理及操作內部設備時的注意事項

### ⚠ WARNING



不要自行拆卸、修理或改造本伺服器。



除本書記載的情況外，不要進行拆卸、修理、改造。否則，不但可能導致設備不能進行正常運行，還有發生觸電和火災的危險。



不要看光碟機內部。



光碟機使用了雷射，請不要在電源打開的狀態下觀看內部或插入鏡子等。雷射射入眼睛有導致失明的危險（雷射肉眼看不見）。



不要擅自拆除鋰電池。

本產品內部安裝有鋰電池。請不要拆下電池。鋰電池靠近火或浸水均有可能發生爆炸。

由於電池使用期限而導致設備不能正常運行時，不要自行拆卸、更換、充電等，請與經銷商或維護服務公司聯繫。



清潔伺服器前請拔下電源插座。



整理或拆裝本設備內部的選購配置時，要切斷設備電源，並拔下電源插頭。即使已關閉電源，但連接著電源線，接觸到任何內部設備也有觸電的危險。



另外，請經常拔下電源插頭，用乾布擦拭灰塵和附著物。有灰塵或水滴等附著時會發熱，有導致火災的危險。

### ⚠ CAUTION



注意高溫

本產品關閉電源後，內置硬碟等內部設備仍然處於高溫狀態。請在充分冷卻之後進行拆裝。



確認安裝完畢。

電源線和信號線、配件板要確實安裝妥當。  
安裝不牢有可能引起接觸不良，可能造成冒煙和著火。

**⚠ CAUTION**



請用保護蓋保護好未使用的介面。

請用保護蓋保護好未使用的電源線介面以防止短路或觸電。從內部設備上拔下電源插頭時，用保護蓋蓋好介面，否則有導致火災或觸電的危險。

**操作注意事項**

**⚠ CAUTION**



不要讓寵物靠近。

寵物的排泄物和毛髮進入設備可能導致火災和觸電。



設備上不要放置物品。

物品倒下可能引起傷亡，破壞硬體或導致火災。



不要將光碟機托盤拉出放置。

防止托盤中進入灰塵引起運轉錯誤。同時防止因碰撞等造成托盤損傷。



不要在打雷時觸摸機器。

打雷時請拔下電源插頭。如來不及拔下電源插頭，請不要觸摸設備及線纜等，防止發生火災或觸電。



不要在設備附近使用行動電話或呼叫器。

在本產品附近時請關閉行動電話及呼叫器電源，防止因電波影響導致運轉錯誤。

## 機架式伺服器的注意事項

### ⚠ WARNING



不要將設備安裝在未指定的機架上。

請將設備安裝在符合EIA標準的19英寸機架上。一定要將設備安裝在指定的機架上才能使用。否則設備可能無法正常使用，並有可能損壞機器零部件或導致人身傷害。關於合適的機架，請與您的經銷商聯繫。



不要在未指定的場所使用本伺服器產品。

不要在未指定的環境中安裝伺服器機架。否則，其他系統可能會受到影響，並且機架脫落可能導致火災或者人身傷害。有關安裝環境和防震技術的詳細事項請參閱附帶的用戶手冊或與經銷商或維護服務公司聯繫。

### ⚠ CAUTION



請小心不要夾住或碰傷手指。

將本機器安裝到機架上或者從機架上卸載的時候，請務必小心以免被滑軌劃傷手指。



請確同時有三人以上一起進行搬運/安裝此伺服器的動作。

為了避免人身傷害，請不要自行將本機器安裝到機架上。應該由受過專業訓練的維護人員來安裝。



安裝機器時不能將機器的所有重量由一個地方來承載。

為了分散重量，應該加裝固定器或者同時安裝兩個或更多的機架，否則機架可能會傾倒導致人身傷害。



不要擅自組裝零部件。

將前門和托架安裝到機架上至少需要兩人共同完成，否則可能會因為零部件跌落而導致損壞或者人身傷害。



不要從不牢固的機架中抽出設備。

在抽出設備之前請確認機架已經被穩固器或者通過抗震技術固定。

**⚠ CAUTION**



不要從機架抽出兩個或者兩個以上的設備。  
同時抽出兩個或者兩個以上的設備可能導致機架傾倒。一次只能抽出一個設備。



不要裝配過多電線。



爲了避免火災和設備損壞，請務必確保不要超過線路的額定負載。有關電力設備的安裝和電線的更多資訊請聯繫電工或者當地的電力公司。



不要在設備運行時拔出設備。

不要拔出或拆除運行中的設備。有導致系統故障和損壞的危險。

## DISPOSAL OF EQUIPMENT AND CONSUMABLES

- When you dispose of the main unit, hard disk drives, floppy disks, CD-ROMs, optional boards, etc., you need to observe your local disposal rules. Dispose the attached power cable along with the equipment to avoid being used with other equipment.

For details, ask your municipal office.

### IMPORTANT:

For disposal (or replacement) of batteries on the motherboard, consult with your sales agent.

If data remains on the hard disk, backup data cartridges, floppy disks, or other writable media (such as CD-R and CD-RW), it could be restored and reused by outsiders. The customer is responsible for wiping out such data before disposal. You need to exercise sufficient care to protect privacy and confidential information.

- Some of the system components have limited lifetime (e.g., cooling fans, built-in batteries, built-in CD-ROM drive, floppy disk drive and mouse). For stable operation, it is recommended to replace them regularly. For lifetime of individual components and replacing procedures, ask your sales agent.

### ⚠ WARNING



Do not detach a lithium battery yourself.

This equipment has a lithium battery. Do not detach it yourself. If the battery is exposed to fire or water, it could explode.  
**RISK OF EXPLOSION IF BATTERY IS REPLACED WITH INCORRECT TYPE.**  
**DISPOSE OF USED BATTERIES ACCORDING TO THE INSTRUCTIONS.**  
When the lithium battery is running down and the equipment does not work correctly, contact your sales agent instead of disassembling, replacing or recharging it yourself.

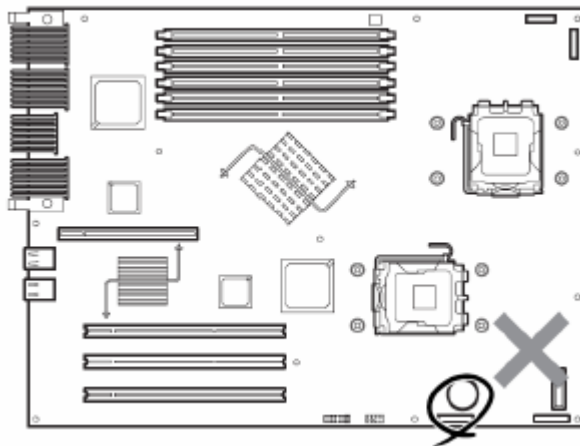

## **IF SYSTEM TROUBLE IS SUSPECTED**

Before sending the equipment for repair, try the following:

- 1.** Check if its power cord and connection cables are attached correctly.
- 2.** See “ERROR MESSAGES” in Chapter 7 to check if there is a relevant symptom. If yes, take measures as instructed.
- 3.** Certain software programs are required for operation of NEC Express5800/ft series. Check if these programs are properly installed.
- 4.** Use a commercially available anti-virus program to check the server.

If the problem is not solved by the above actions, stop using the server and consult with your sales agent. In this case, check LED indications of the server and alarm indications on the display, which will serve as helpful information at the time of repair.

## **ABOUT REPAIR PARTS**

The minimum duration of holding repair parts of this equipment may be different for each country, so contact the NEC sales representatives.

If the period is not specified, the repair parts are kept for 5 years after discontinuance of the product.

## **ABOUT OUR WEB SERVICE**

Information on NEC Express5800/ft series including modification modules is also available on our web site, NEC Express5800 Web Site Asia Pacific, at

<http://www.nec.co.jp/express/index.html>



## Advice for Your Health

Prolonged use of a computer may affect your health. Keep in mind the following to reduce stresses on your body:

### Sit in a good posture

Sit on your chair with your back straight. If the desk height is appropriate, you will slightly look down at the screen and your forearms will be parallel to the floor. This “good” work posture can minimize muscle tension caused by sedentary work.

If you sit in a “bad” posture—for example, sit round-shouldered or with you face too close to the display—you may easily suffer fatigue or have your eyesight affected.



### Adjust the installation angle of Display

Most types of displays allow you to adjust the angle vertically and horizontally. This adjustment is very important to prevent the reflection of light as well as to make the screen more comfortable to see. Without this adjustment, it is difficult to maintain a “good” work posture and may get tired soon. Be sure to adjust the angle before using the display.

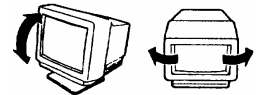

### Adjust Brightness and Contrast

Displays allow you to adjust brightness and contrast. Optimum brightness and contrast vary depending on the individual, age, brightness of the room, etc; you need to make an adjustment accordingly. If the screen is too bright or too dark, it is bad for your eyes.

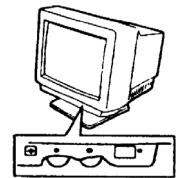

### Adjust the installation angle of Keyboard

Some types of keyboards allow you to adjust the angle. If you adjust the angle to make the keyboard more comfortable to use, you can greatly reduce stresses on your shoulders, arms, and fingers.

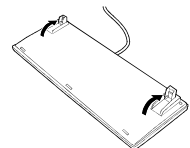
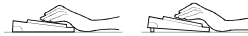

### Clean the Equipment

Cleanliness of the equipment is very important not only for reasons of appearance but also from the viewpoints of function and safety. Especially, you need to regularly clean the display, which gets unclear due to the accumulation of dirt.

### Take a break when you get tired

If you feel tired, you are recommended to refresh yourself by taking a short break or doing a light exercise.



(This page is intentionally left blank.)

# Chapter 2

---

## General Description

This chapter describes what you need to know to use the NEC Express5800/ft series. Refer to this chapter when you want to know about certain components and how to operate them.

## STANDARD FEATURES

### High performance

- Dual-Core Intel® Xeon® Processor (320Fb-L, 320Fb-LR: 1.6GHz)
- High-speed Ethernet interface (1000Mbps/100Mbps/10Mbps supported)
- High-speed disk access (Ultra320 SCSI)

### Expandability

- Three slots (low profile) of PCI bus (100MHz)
- Large memory of up to 12 GB
- Remote power-on feature
- USB interface
- Backup device bays as standard equipment (320Fb-L)

### High-reliability

- Memory monitoring feature (1-bit error correction/ 2-bit error detection)
- Bus parity error detection
- Temperature monitoring
- Error notification
- Built-in fan monitoring feature
- Internal voltage monitoring feature
- BIOS password feature
- Security feature (security lock for front bezel)

### Management Utilities

- NEC ESMPRO
- NEC DianaScope

### Ready-to-use

- Quick cableless connection: hard disk, CPU/IO module, POWER

### Fault-tolerant Feature

- Redundant modules achieved within a system
- Higher hardware availability by isolation of failed module

### Various Features

- Graphic accelerator "ES1000" supported
- El Torito Bootable CD-ROM (no emulation mode) format supported
- POWER switch mask
- Remote power-on feature
- AC-LINK feature

### Self-diagnosis

- Power On Self-Test (POST)
- Test and Diagnosis (T&D) Utility

### Maintainability

- Off-line Maintenance Utility

### Easy and Fine Setup

- NEC EXPRESSBUILDER (system setup utility)
- SETUP (BIOS setup utility)
- SCSI*Select* (SCSI device utility)

The NEC Express5800/ft series achieves fault-tolerant high-availability in a space-saving form factor by incorporating redundant hardware module pairs in a single chassis. These modules work in synchronous tight lockstep while constantly making comparisons with each other and detecting anomalous diversions in operation.

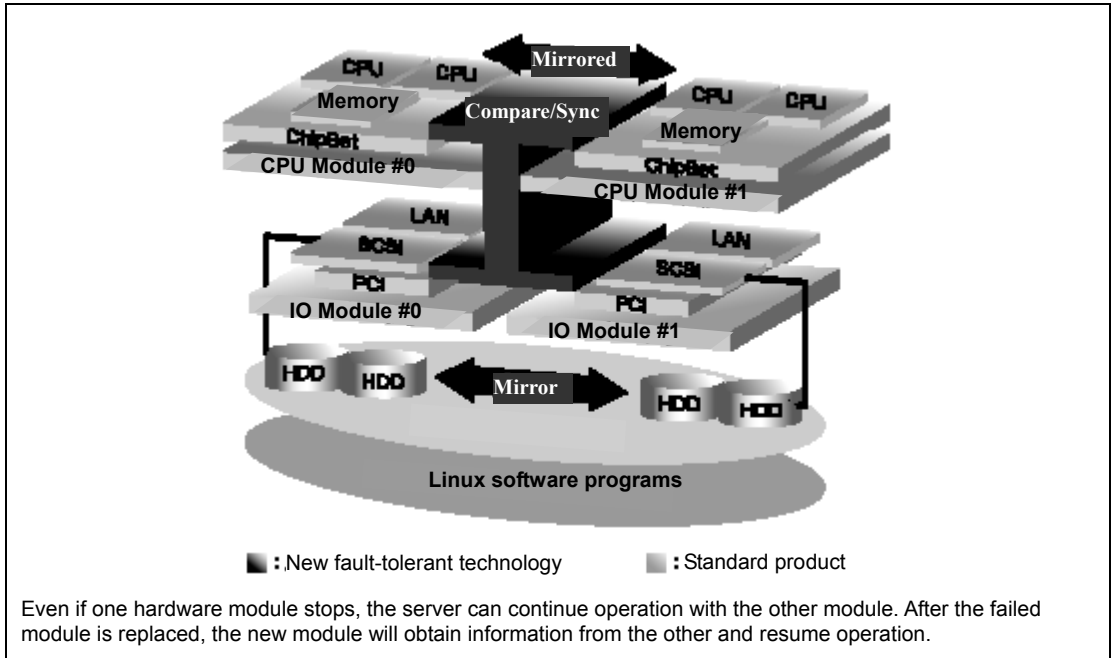

NEC Express5800/ft series is a highly fault-tolerant server that achieves continuous computing operations, data storage mirror, and continuous network connection. It allows you to run Linux-based applications.

NEC Express5800/ft series achieves continuous computing operations for the Linux server and server-based applications with its redundant CPU processing and redundant memory. It assures data redundancy through duplication of server data on an independent storage system. These features eliminate server downtime that is usually caused by network disconnection or trouble with the I/O controller, Ethernet adapter or disk drive, and support operation of the network and server applications continuously. While being transparent to application software, NEC Express5800/ft series achieves high fault-tolerance.

NEC Express5800/ft series detects status changes, errors and other events and notifies the user of these events. If you use an alarm notification tool, you can configure NEC Express5800/ft series to notify you when certain events occur.

NEC ESMPRO is installed on the system as a server management solution. NEC ESMPRO, a GUI-based management tool, allows you to monitor, view, and configure NEC Express5800/ft series. This tool also supports both local and remote management of NEC Express5800/ft series.

NEC Express5800/ft series mainly provides the following advantages:

- **Highly fault-tolerant processing and I/O subsystems**

NEC Express5800/ft series use redundant hardware and software to assure server operation even if one module suffers trouble with its processor, memory, I/O (including trouble related to the I/O controller), disk drive, or Ethernet adapter.
- **Continuous network connection**

NEC Express5800/ft series maintains continuous network connection by detecting any trouble with the network adapter, connection, etc. If trouble occurs, the standby network connection will take over all network traffic processing and thus securely maintain the network system connection of NEC Express5800/ft series without losing network traffic or client connection.
- **Support of multiple network connections**

Since NEC Express5800/ft series can support multiple Ethernet connections, you can add network redundant control or network traffic control.
- **Industry standard hardware platform**

NEC Express5800/ft series uses IA (Intel Architecture)-based system hardware.
- **No need to modify applications**

You can run Linux-compliant applications on NEC Express5800/ft series. Thus, unlike other highly fault-tolerant products, special API or scripts are not necessary.
- **Automatic mirroring**

NEC Express5800/ft series automatically maintains data as the current data.
- **Automatic detection and notification of faults**

NEC Express5800/ft series detects and sorts out all events such as general status changes and faults, and records these events to syslog.
- **Transparent migration**

NEC Express5800/ft series constantly monitors events. If trouble occurs on NEC Express5800/ft series' server module, it will transparently use a redundant module of the failed module. This feature maintains data and user access without losing application service.
- **Automatic reconfiguration**

When the failed module restarts after the trouble is corrected, NEC Express5800/ft series will perform reconfiguration automatically, and if necessary, resynchronize the affected modules. Reconfiguration can include CPU processing (e.g., CPU memory), server's operating system (and related applications), and system data stored on the hard disks. In most cases, NEC Express5800/ft series automatically restores redundancy of the server modules after recovery.

- Local and remote management

NEC Express5800/ft series uses NEC ESMPRO as a server management tool. This tool uses a GUI that enables monitoring and setting of NEC Express5800/ft series. NEC ESMPRO can be used both locally and remotely on work station PCs or server PCs.

- Syslog function

When a trouble or other event is detected on NEC Express5800/ft series, they will be recorded in syslog.

- In-service repairing

You can repair or replace a failed module even if NEC Express5800/ft series is operating.

## NAMES AND FUNCTIONS OF COMPONENTS

Names and functions of components are shown below:

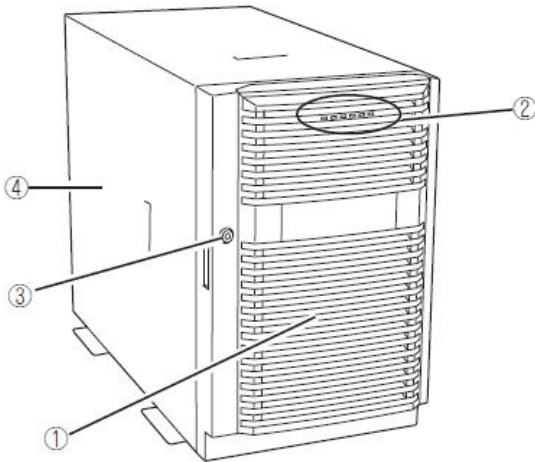

- (1) **Front door**  
The cover to protect devices in the front in daily operations: this cover can be locked by the security key shipped together.
- (2) **LEDs**  
For more information, see the description on the front view (page 2-7).
- (3) **Key slot**  
The slot you insert the security key to unlock the front door
- (4) **Drive cover**  
The cover to be detached when removing the backup device bay

Tower model

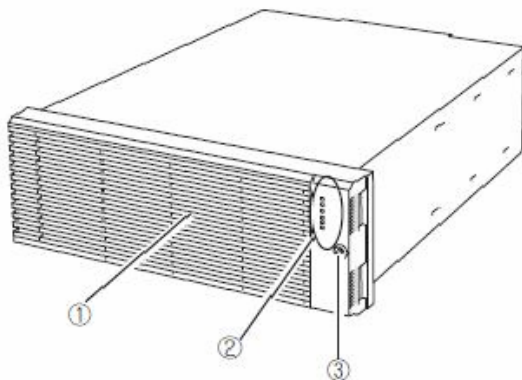

- (1) **Front bezel**  
The cover to protect devices in the front: this cover can be locked by the security key shipped together.
- (2) **LEDs**  
For more information, see the description on the front view (page 2-11).
- (3) **Key slot**  
The slot you insert the security key to unlock the front bezel.

Rack-mount model



## Front View (inside)

The following illustrations show components in the front of the tower model and the rack model.

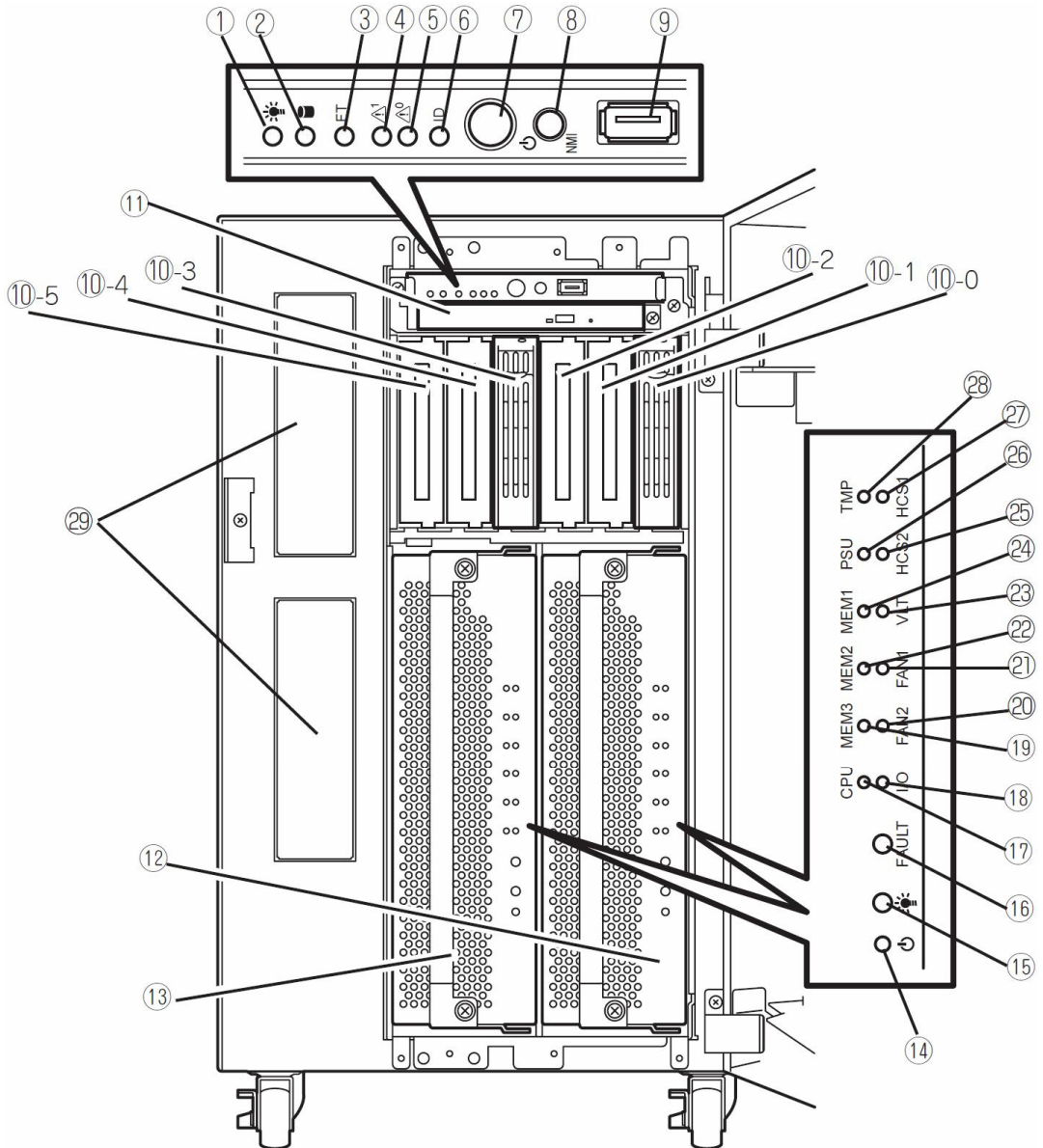

Tower model  
(with the front door open)

**(1) POWER LED (green)**

This LED illuminates when the power supply is switched on (see page 2-22).

**(2) DISK ACCESS LED (green/amber)**

This LED illuminates in green when the internal hard disk drives are accessed. If any internal hard disk drive is failing, the LED illuminates in amber (see page 2-22).

**(3) FT status LED (green/amber)**

This LED indicates the status of the server (see page 2-23).

In the Duplex mode, the LED illuminates in green.

In the Simplex mode, the LED does not illuminate.

If either of the CPU/IO modules fails, the LED illuminates in amber. While memory dump is being performed, this LED blinks in amber.

**(4) CPU/IO module #1 status LED**

This LED indicates the status of the CPU/IO module #1 (see page 2-24). When the module is running successfully, the LED illuminates in green. If the module has a problem, the LED blinks in green, illuminates in amber, or blinks in amber.

**(5) CPU/IO module #0 status LED**

This LED indicates the status of the CPU/IO module #0 (see page 2-24). When the module is running successfully, the LED illuminates in green. If the module has a problem, the LED blinks in green, illuminates in amber, or blinks in amber.

**(6) UID LED (blue)**

This LED blinks by a command from software.

**(7) POWER switch**

This switch is used to power on/off the server. The POWER LED illuminates and the server is powered on when this switch is pressed once (see page 2-30). The power supply is turned off when the switch is pressed once again (see page 2-31). Pressing this button for 4 or more seconds shuts down the server forcefully (see page 4-37).

**(8) DUMP (NMI) switch**

This switch is used to perform memory dump.

**(9) USB1 connector**

This connector is used for connecting devices supporting the USB1.1 interface.

**(10) Hard disk drive bays**

These bays are used to install hard disk drives (see page 8-6).

The numbers following “-” represent SCSI IDs.

**(11) CD-ROM drive**

This device is used to read data from CD-ROMs.

**(12) CPU/IO module #0**

This is a module with a set of CPU (processor), memory (DIMM), PCI board, and cooling fan unit (see page 2-18).

**(13) CPU/IO module #1**

This is a module with a set of CPU (processor), memory (DIMM), PCI board and cooling fan (see page 2-18).

**(14) Module POWER switch**

This switch is used to control power supply to a module. The switch is pressed when removing a failed module.

**(15) Module POWER LED**

See page 2-25.

**(16) Module FAULT LED**

See page 2-25.

**(17) Processor error LED**

See page 2-25.

**(18) I/O error LED**

See page 2-25.

**(19) Memory group 3 error LED**

See page 2-25.

**(20) Fan 2 error LED**

See page 2-25.

**(21) Fan 1 error LED**

See page 2-25.

**(22) Memory group 2 error LED**

See page 2-25.

**(23) Voltage error LED**

See page 2-26.

**(24) Memory group 1 error LED**

See page 2-25.

**(25) HCS2 error LED**

See page 2-26.

**(26) Power supply unit error LED**

See page 2-26.

**(27) HCS1 error LED**

See page 2-26.

**(28) Heat warning LED**

See page 2-26.

**(29) Backup device bays**

These bays are used to install optional drives such as DAT or AIT drives.

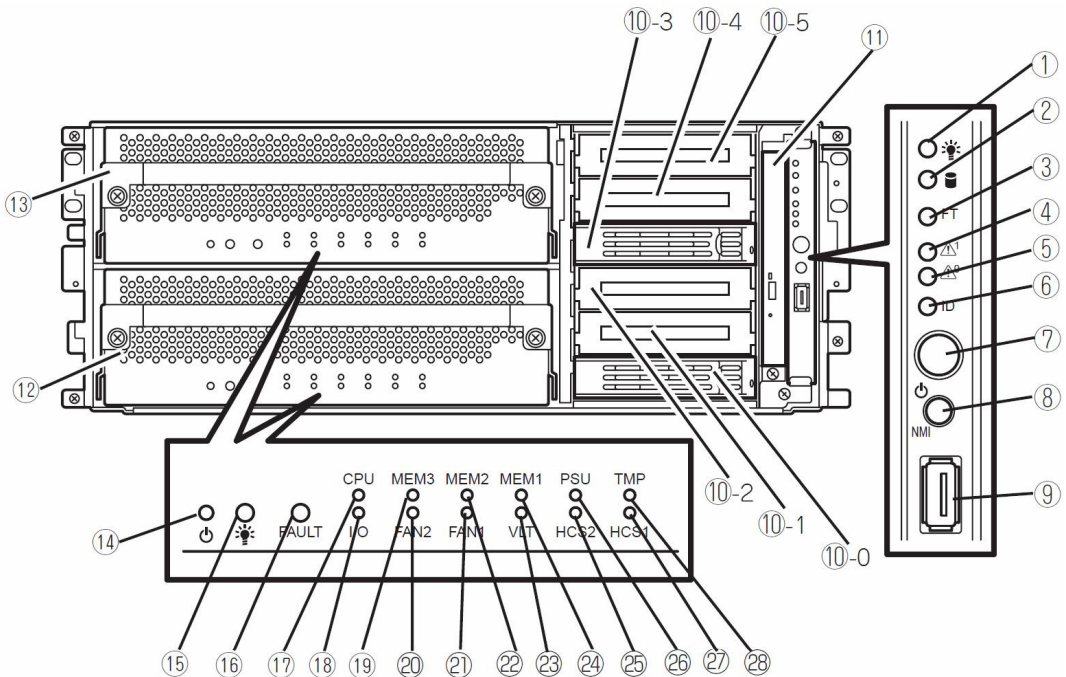

Rack model  
(with the front door open)

**(1) POWER LED (green)**

This LED illuminates when the power supply is switched on (see page 2-22).

**(2) DISK ACCESS LED (green/amber)**

This LED illuminates in green when the internal hard disk drives are accessed. If any internal hard disk drive is failing, the LED illuminates in amber (see page 2-22).

**(3) FT status LED (green/amber)**

This LED indicates the status of the server (see page 2-23).

In the Duplex mode, the LED illuminates in green.

In the Simplex mode, the LED does not illuminate.

If either of the CPU/I/O modules fails, the LED illuminates in amber. While memory dump is being performed, this LED blinks in amber.

**(4) CPU/I/O module #1 status LED**

This LED indicates the status of the CPU/I/O module #1 (see page 2-24). When the module is running successfully, the LED illuminates in green. If the module has a problem, the LED blinks in green, illuminates in amber, or blinks in amber.

**(5) CPU/I/O module #0 status LED**

This LED indicates the status of the CPU/I/O module #0 (see page 2-24). When the module is running successfully, the LED illuminates in green. If the module has a problem, the LED blinks in green, illuminates in amber, or blinks in amber.

**(6) UID LED (blue)**

This LED blinks by a command from software.

**(7) POWER switch**

This switch is used to power on/off the server. The POWER LED illuminates and the server is powered on when this switch is pressed once (see page 2-30). The power supply is turned off when the switch is pressed once again (see page 2-31). Pressing this button for 4 or more seconds shuts down the server forcefully (see page 4-37).

**(8) DUMP (NMI) switch**

This switch is used to perform memory dump.

**(9) USB1 connector**

This connector is used for connecting devices supporting the USB1.1 interface.

**(10) Hard disk drive bays**

These bays are used to install hard disk drives (see page 8-6).

The numbers following “-” represent SCSI IDs.

**(11) CD-ROM drive**

This device is used to read data from CD-ROMs.

**(12) CPU/IO module #0**

This is a module with a set of CPU (processor), memory (DIMM), PCI board, and cooling fan unit (see page 2-24).

**(13) CPU/IO module #1**

This is a module with a set of CPU (processor), memory (DIMM), PCI board and cooling fan (see page 2-24).

**(14) Module POWER switch**

This switch is used to control power supply to a module. The switch is pressed when removing a failed module.

**(15) Module POWER LED**

See page 2-25.

**(16) Module FAULT LED**

See page 2-25.

**(17) Processor error LED**

See page 2-25.

**(18) I/O error LED**

See page 2-25.

**(19) Memory group 3 error LED**

See page 2-25.

- (20) Fan 2 error LED**  
See page 2-25.
- (21) Fan 1 error LED**  
See page 2-25.
- (22) Memory group 2 error LED**  
See page 2-25.
- (23) Voltage error LED**  
See page 2-26.
- (24) Memory group 1 error LED**  
See page 2-25.
- (25) HCS2 error LED**  
See page 2-26.
- (26) Power supply unit error LED**  
See page 2-26.
- (27) HCS1 error LED**  
See page 2-26.
- (28) Heat warning LED**  
See page 2-26.

---

## CD- ROM Drive

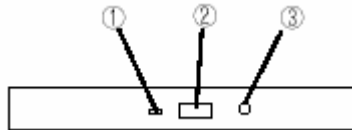

**(1) Status LED**

An LED that stays on while the loaded CD-ROM is accessed.

**(2) CD tray eject button**

A button for ejecting the CD tray.

**(3) Manual release hole**

When the eject button does not work, insert a metal pin into this hole to forcefully eject the CD tray.



**Rear View**

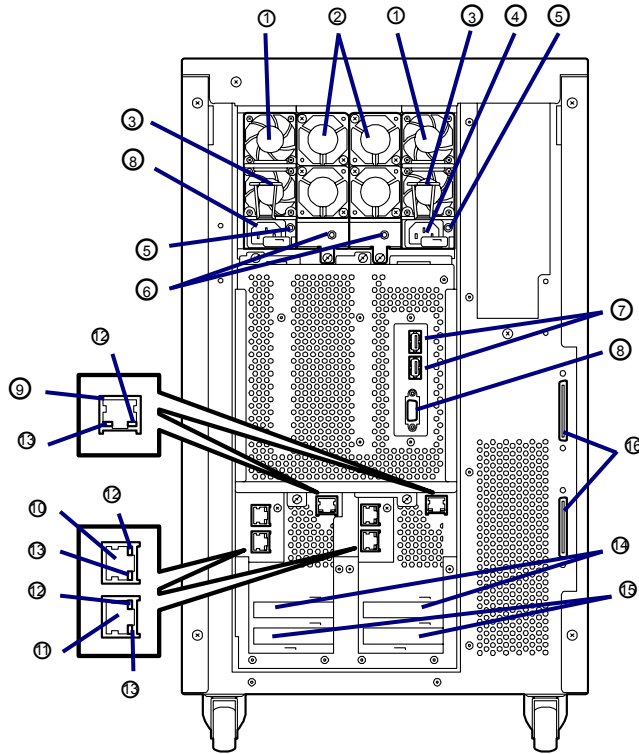

Tower model

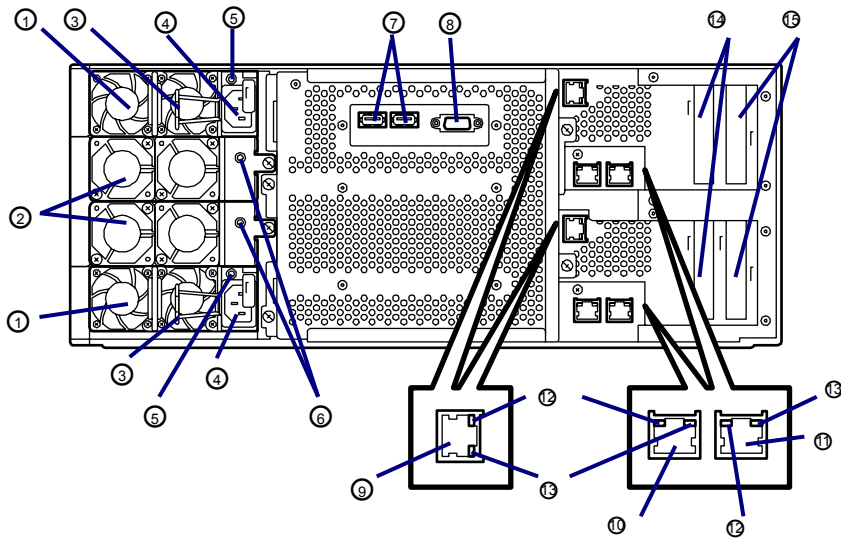

Rack model

**(1) Power supply units**

Power supply units supply DC power to the server.

**(2) Cooling fan unit 2**

**(3) Lock springs**

A lock spring prevents a power supply cord from disconnected from this device.

**(4) AC inlets**

A power cord is connected to this socket.

**(5) Power supply unit LEDs**

A power supply unit LED blinks in green when AC power is supplied via a power cord. When the server is powered on, the LED illuminates in green (see page 2-27).

**(6) Cooling fan LEDs**

A cooling fan LED illuminates in green while a cooling fan unit is working normally. If the fan unit has a problem, the LED illuminates in amber (see page 2-27).

**(7) USB connectors**

From left to right, USB2 and USB3. The connectors are used for connecting devices supporting the USB1.1 interface.

**(8) Monitor connector**

This connector is used to connect a display device

**(9) Management LAN port**

This is a LAN port dedicated to management and can be used when a fit remote management card is installed. The port is used when the remote management function or NEC DianaScope is used (optional for 320Fb-L, 320Fb-LR models).

**(10) LAN connector 1**

This connector is used to connect to a network.

**(11) LAN connector 2**

This connector is used to connect to a network.

**(12) LINK/ACT LEDs**

A LINK/ACT LED indicates the LAN access status (see page 2-27).

**(13) Speed LEDs**

A speed LED indicates the transfer speed of the LAN (see page 2-27).

**(14) PCI-X slot #1**

64 bit 100MHz 3.3V PCI-X. A PCI board of low-profile type is attached to this slot.

**(15) PCI-X slot #2**

64 bit 100MHz 3.3V PCI-X. A PCI board of low-profile type is attached to this slot.

**(16) SCSI connector**

This connector is used to connect the internal backup device (optional) and N8803-032 SCSI board (only for tower model).

---

## CPU/IO Module

- 1) Module handle
- 2) Cooling fan unit 1
- 3) Heat sink (CPU#1)
- 4) PCI slot
- 5) DIMM

For more information on slot numbers, see the figure on next page.

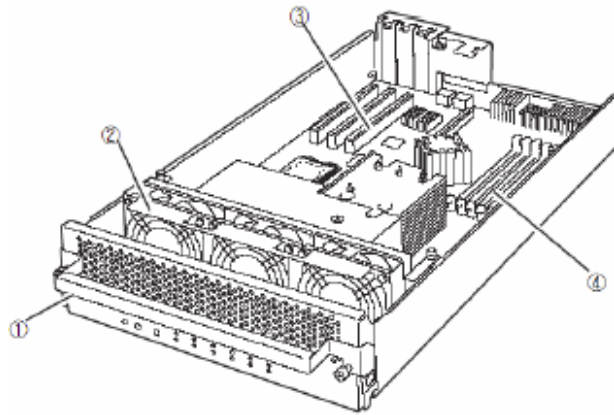

PCPU/IO module (without a water-cooling kit)  
(320Fb-L/320FbLR model)

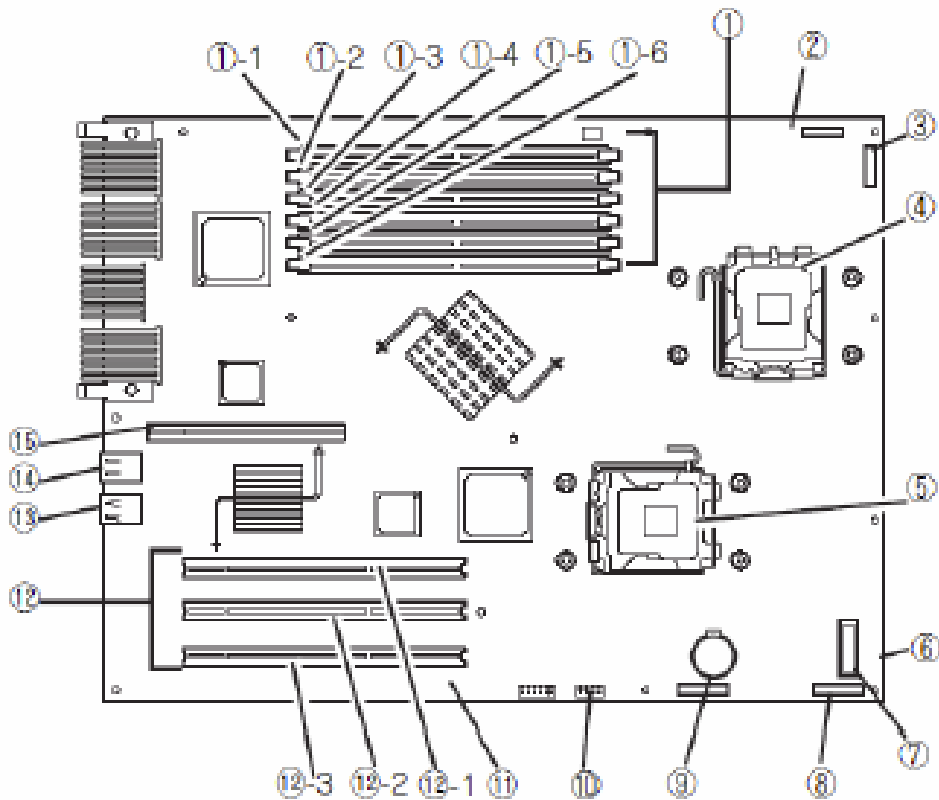

CPU/IO module board

- (1) DIMM slots
  - (1)-1 DIMM slot A1
  - (1)-2 DIMM slot B1
  - (1)-3 DIMM slot A2
  - (1)-4 DIMM slot B2
  - (1)-5 DIMM slot A3
  - (1)-6 DIMM slot B3
- (2) HCS-A connector (unavailable)
- (3) Fan connector (unavailable)
- (4) Processor #1 socket (CPU#1)
- (5) Processor #2 socket (CPU#2)
- (6) Fan connector
- (7) LED board connector
- (8) HCS-B connector (unavailable)

- (9)** Lithium battery
- (10)** Jumper switch for BMC configuration
- (11)** Jumper switch for CMOS/password clearing
- (12)** PCI board slot
  - (12)-1 PCI board slot 1
  - (12)-2 PCI board slot 2
  - (12)-3 PCI board slot 3
- (13)** LAN2 connector
- (14)** LAN1 connector
- (15)** ft remote management card connector

---

## ft Remote Management Card

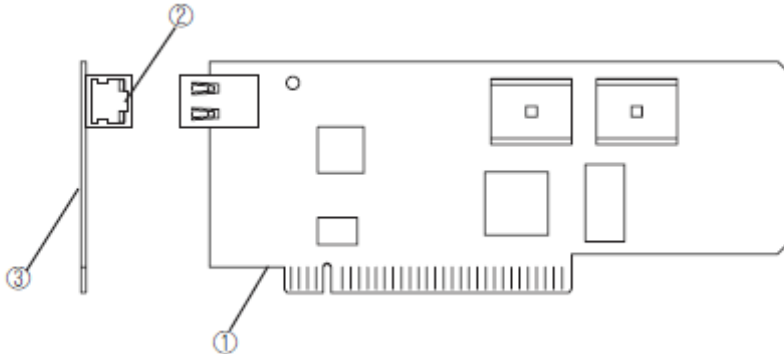

(1) **Edge connecting to a server**

This edge of the card connects to the connector for this card in this device

---

**IMPORTANT:**

Attaching this card to a slot or device other than those specified may cause problems. Do not attach this card to any non-specified slot or device.

---

(2) **Management LAN port**

This port supporting 100Mbps/10Mbps is used to connect to a network. You cannot use this port to connect to a telephone line directly. This port is also used for management by NEC DianaScope, the management software shipped with the server.

■ **LINK/ACT LED**

This LED indicates the network port status. When power is supplied to this card and a connected device such as a hub and they are connected properly, the LED illuminates in green (LINK). When the network port is sending/receiving data successfully the LED blinks in green (ACT).

■ **Speed LED**

This LED indicates the network interface on which network port's communication mode is running. When the LED illuminates in amber, it indicates the network interface is working on 100Mbps. If the LED does not illuminate, it indicates the network interface is working on 10Mbps.

(3) **MAC address**

The label containing MAC address information is attached on the other side of this card. You can also check the MAC address on the BIOS setup screen on the server.

## **LEDs**

This section describes indications and meanings of the LEDs on NEC Express5800/ft series.

See “NAMES AND FUNCTIONS OF COMPONENTS” (pages 2-6 through 2-17) for the locations of each LED.

### **POWER LED**

This LED illuminates in green while the server is powered on. When power is off, this LED does not illuminate. The LED also illuminates in green when one of CPU/IO modules is powered on.

### **DISK ACCESS LED**

This LED indicates the status of hard disk drives loaded on 3.5-inch disk bays. Whenever the hard disk drives are accessed, the LED blinks in green.

When this LED illuminates in amber, it indicates a hard disk drive has a problem. You can see the status of the failed hard disk drive by checking the LED of each hard disk drive.

If this LED is blinking in amber, it indicates volumes in hard disk drives are not mirrored. See “HARD DISK CONFIGURATIONS THAT CAN BE BUILT ON THE NEC Express5800/ft series” (page 3-2) to configure mirror volumes.



## FT Status LED

The LED stays green while the server is running normally in DUPLEX mode. If this LED does not illuminate or illuminates/blinks in amber, there is something wrong with the server.

The table below shows indications of the FT Status LED and their meanings.

FT status LED indications	Description	Action
Green	The device is running successfully in the Duplex mode.	–
Not on	Power is off	–
	Performing POST.	Wait for a while; it will illuminate in green and the mode will become Duplex shortly after POST.
	The device is running in the Simplex mode	The LED indicates only one of modules is running. If this status is observed right after the system startup or activation of a module that has been stopped, wait for a while. The status will change to the Duplex mode with the LED lit in green. If the LED does not illuminate in green after a few minutes, a device (LAN, FC-connected storage, or internal disk) that should be redundant may not be attached properly. Check to see devices to make sure they achieve redundancy.
Amber	One of the CPU/IO modules has a problem.	Check the CPU/IO module status LEDs to find the failing module, and then report your sales agent which LED of the failing module is blinking.
Blinking in amber	Memory dump is being performed.	Wait for memory dump to be completed.

**CPU/IO Module # 0 Status LED****CPU/IO Module # 1 Status LED**

These LEDs illuminate in green when this device is running successfully. If a LED is off, blinks in green, or illuminates/blinks in amber, the device has a problem.

The table below shows indications of CPU/IO module status LEDs, their meanings, and actions to be taken.

<b>CPU/IO status LED indications</b>	<b>Description</b>	<b>Action</b>
Green	The CPU/IO module is running successfully.	–
Blinking in green	A number of errors that can be fixed by memory are occurring.	Although you can continue using the server, it is recommended to contact your service agent.
	The CPU/IO module handle is not firmly fixed.	Check to see the CPU/IO module is firmly loaded and then fasten the screws of the handle to fix the handle.
Not on	Power supply is off.	–
	POST is running.	Wait for a while; the LED will illuminate in green and the mode will become Duplex shortly after POST.
	A fatal hardware error has occurred.	Contact your sales agent.
Amber	One of the CPU/IO modules has a problem.	Check the CPU/IO module status LEDs to find the failing module, and then report your sales agent which LED of the failing module is blinking.
	Detected a fatal temperature error.	Check if dust is accumulated on internal fans and confirm that the fan cables are connected firmly. If the LED indication does not change, contact your sales agent.
	Detected a fatal voltage error.	Contact your sales agent.
	Power supply has a problem.	Contact your sales agent.
Amber (blinking)	Detected a temperature error to be warned.	Check if dust is accumulated on internal fans and confirm that the fan cables are connected firmly. If the LED indication does not change, contact your sales agent.
	Detected a voltage error to be warned.	Contact your sales agent.
	Detected a fan alarm.	Check if dust is accumulated on internal fans, and confirm that the fan cables are connected firmly. If the LED indication does not change, contact your sales agent.

## **UID LED**

This LED blinks in blue by NEC ESMPRO Manager, NEC DianaScope or remote management of WEB server functions to identify the targeted device for maintenance. Use this LED when you have two or more of this device model on a single rack.

When you are finished with maintenance, switch off the UID LED.

## **Module POWER LED**

This LED illuminates in green while the CPU/IO module is powered on. When the CPU/IO module is not powered on, this LED is off.

When the LED is illuminating, you cannot remove the module.

## **Module FAULT LED**

This LED illuminates in amber when the CPU/IO module has a problem.

## **Processor Error LED**

This LED illuminates in amber when the processor of the CPU/IO module has a problem.

## **I/O Unit Error LED**

This LED illuminates in amber when the I/O of the CPU/IO module has a problem.

## **Memory Group 1 Error LED**

This LED illuminates in amber when the memory group 1 (A1 and B1 DIMM slots) of the CPU/IO module has a problem.

## **Memory Group 2 Error LED**

This LED illuminates in amber when the memory group 2 (A2 and B2 DIMM slots) of the CPU/IO module has a problem.

## **Memory Group 3 Error LED**

This LED illuminates in amber when the memory group 3 (A3 and B3 DIMM slots) of the CPU/IO module has a problem.

## **Fan 1 Error LED**

This LED illuminates in amber when the cooling fan unit in the CPU/IO module has a problem.

## **Fan 2 Error LED**

This LED illuminates in amber when the cooling fan unit located at the rear of this server has a problem.

### **Power Supply Unit Error LED**

This LED illuminates in amber when the corresponding power supply unit located at the rear of the server has a problem.

### **Voltage Error LED**

This LED illuminates in amber when the voltage of the CPU/IO module is not within an appropriate range.

### **Heart Warning LED**

This LED illuminates in amber when the temperature in the CPU/IO module is not within an appropriate range.

### **HCS 1 Error LED**

Unavailable

### **HCS 2 Error LED**

Unavailable

### **Access LED on the CD-ROM Drive**

This LED illuminates when the installed CD-ROM is being accessed.

### **Hard Disk Drive LED**

Each indication of the DISK LED on a hard disk drive bay has a different meaning.

Blinks in green: the hard disk drive is being accessed.

Illuminates in amber: the hard disk drive has failed.

Illuminates in green and amber in turn: the hard disk drive reconfiguration (rebuild) is ongoing. This does not indicate the hard disk drive has a problem.

When the rebuilding is completed the LED goes off. If the rebuilding fails, the LED illuminates in amber.

Blinks in amber: the hard disk drive has a mirror volume for which redundancy is not achieved (i.e. mirrored configuration is in the degenerated mode).

## LAN Connector LED

- LINK/ACT LED

The LINK/ACT LED shows the status of a standard network port. It is green if power is supplied to the main unit and hub, and they are connected correctly (“LINK”). It blinks green while the network port sends or receives data (ACT).

When the LED does not illuminate during “LINK,” check the condition and connection of network cables. If there is nothing wrong with the cables, a defect is suspected in the network (LAN) controller. In this case, contact your sales agent.

- Speed LED

This LED indicates the network interface of the communication mode used by a network port.

1000BASE-T and 100BASE-TX are the supported LAN port types. When this LED illuminates in amber, the port is operating on 1000BASE-T. When the LED illuminates in green, the port is operating on 100BASE-TX.

## Power Supply Unit LED

Power supply units located at the rear have power supply unit LEDs. When power is supplied to a power supply unit by connecting a power cord to the AC inlet of the power supply unit, its LED blinks in green. When the server is powered on, the LED illuminates in green. If the LED does not illuminate in green or illuminates/blinks in amber, the power supply unit may be failing. Contact your service agent and ask for replacement of the power supply unit.

## Cooling Fan LED

Cooling fan units located at the rear have cooling fan LEDs. While a cooling fan unit is working normally, its LED illuminates in green. When the LED illuminates in amber, the fan unit may have a problem. Contact your service agent and ask for the replacement of the cooling fan unit.

## BASIC OPERATION

This section describes basic operation procedures of NEC Express5800/ft series.

---

### Security lock (front door lock) (for tower model)

The security lock located at the front of this server locks the front door. Open the front door to power on/off the server, operate the CD-ROM drive or 5.25-inch device, or install/remove a hard disk drive on a 3.5-inch disk bay or CPU/IO module.

---

#### IMPORTANT:

The security lock can be unlocked only by the security keys shipped together.

Some software programs have commands to eject media on the tray of a CD-ROM drive or device installed in a 5.25-inch device bay. Before you run any of these commands, make sure the front door is open. If you run the command with the front door closed, the media on the CD-ROM tray or 5.25-inch device bumps against the door and the server can get damaged.

---

To open the front door, unlock it and then hold the handle located in the right middle of the door gently and pull it toward you. When you close the front door, it is recommended to lock it for



security reasons.

Front door locked

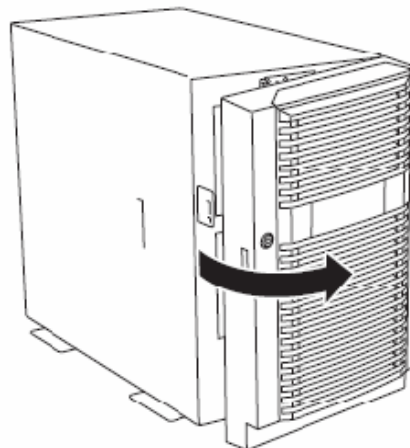

---

## Installing/Removing the Front Bezel

When you power on/off the server, operate the CD-ROM drive, or remove/install a hard disk drive or CPU/IO module, remove the front bezel.

---

### IMPORTANT:

Front bezel cannot be opened without inserting the attached security key into the slot to release the lock.

---

1. Insert the security key into the slot and turn it left with a little pressure to release the lock.
2. Hold the right side of the front bezel lightly and pull it toward you.

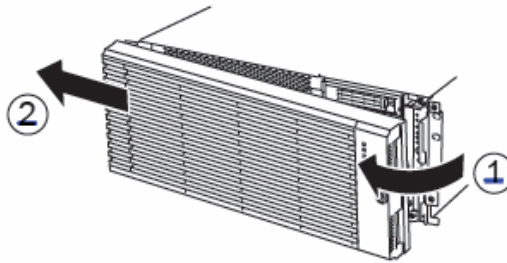

3. Detach the front bezel from the main unit by sliding it to the left a little to disengage the tabs from the frame.

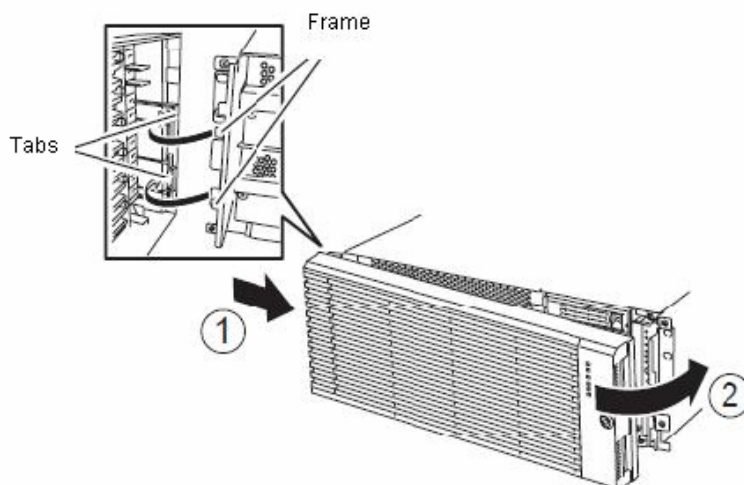

To attach the front bezel, engage the tabs on the frame on the left side of the main unit. After attaching and closing the front bezel, lock it with the key for security.

---

## Power ON

To power on NEC Express5800/ft series, press the POWER switch located on the right of the front panel.

Follow the steps below to turn on the power.

1. Power on the display unit and other peripheral devices connected to the server.

---

### CHECK:

If the power cord is connected to a power controller like a UPS, make sure that it is powered on.

---

2. Press the power switch located on the right of the front panel.

The POWER LED illuminates in green. After a while, the "NEC" logo will appear on the screen.

---

### IMPORTANT:

- When you connect a power cord to an AC inlet, wait ten or more seconds to press the POWER switch.
  - Do not turn off the power before you see the "NEC" logo and a character below the logo. It may take one to five minutes for the logo to appear depending on your server configuration.
- 

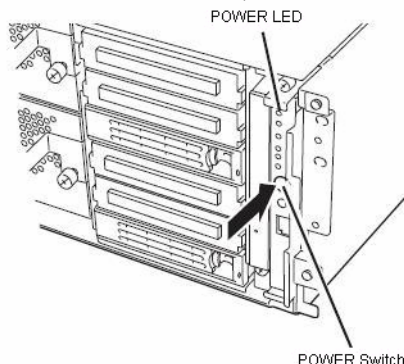

While the "NEC" logo is displayed on the screen, NEC Express5800/ft series is performing a power-on self test (POST) to check itself. For details, see "POST Check" described later in this chapter. Upon the completion of POST, the OS will start.

---

### CHECK:

If the server finds errors during POST, it will interrupt POST and display the error message. See Chapter 7.

---



---

## Power OFF

Follow the steps below to turn off the power. If NEC Express5800/ft series is plugged to a UPS, see manuals included with the UPS or the application that controls the UPS.

1. Perform a normal shutdown from Linux by running the shutdown command.  
Press the POWER switch to power off the server.
2. Power off all peripheral devices.

---

## POST Check

POST (power-on self test) is a self-test function stored on the motherboard of NEC Express5800/ft series.

When you power on the server, POST will start automatically to check the motherboard, ECC memory modules, CPU modules, keyboard, mouse, etc. It also shows startup messages for various BIOS setup utilities.



According to the factory default settings, the “NEC” logo appears on the display while POST is being performed. (To view POST’s details, press **Esc**.)

---

### TIPS:

- You can view POST details from the beginning without the need to press **Esc** when the BIOS menu is displayed: select [System Configuration] - [Advanced], and set [Boot-time Diagnostic Screen] to "Enabled" (see Chapter 4).
  - You can view the test items and details from a management PC where NEC ESMPRO Manager or NEC DianaScope is installed.
- 

You do not always need to check POST details. You will need to check messages when:

- You install a new NEC Express5800/ft series.
- A failure is suspected.
- You hear several beeps between the time of the power-on and OS start-up.
- The display unit shows an error message.

## Flow of POST

This section walks you through how POST is performed.

1. When you power on the system, one selected CPU/PCI module will start up.

POST will be performed on this selected CPU/PCI module.

2. Memory check starts.

A message appears at the upper left of the screen to show that the basic and expanded memories are being counted. The memory check may take a few minutes to complete depending on the server's memory size. Likewise, it may take about one minute for the screen to appear when the server is rebooted.

Note that if you have replaced the PCI module, the server will perform a reset of the MAC address, then reboot itself before the memory check.

3. The server starts processor check, IO check, and initialization.

Several messages appear: they show the ID of the selected CPU/PCI modules, information on the processor, detection of the keyboard and mouse, etc.

4. A message appears at the lower left of the screen, prompting for startup of the BIOS setup utility "SETUP."

Press <F2> to enter SETUP

You will need to start it when you want to modify the configuration for using the server. Unless this message appears together with an error message, you do not need to start the utility to modify the configuration. (If you wait for a few seconds, POST will go on automatically.)

To start the SETUP utility, press **F2** while the above message is displayed. For setting and parameter functions, see the section of BIOS setup.

When SETUP is completed, the server will reboot itself automatically and perform POST.

5. A message appears prompting for startup of SCSI BIOS setup utility.

When a built-in SCSI controller is detected, a message will appear prompting for startup of SCSI BIOS setup utility. (If you wait for a few seconds, POST will go on automatically.)

If you press **Ctrl + N**, the SCSI BIOS setup utility will start. For setting and parameter functions, see "SCSI BIOS (SCSISelect)" (page 4-30).

You will need to use this utility, for example, when you have changed the server's internal SCSI device connections. However, you usually do not need to use it.

When SETUP is complete, the server will reboot automatically and perform POST again.

If multiple SCSI controller boards are mounted on the PCI bus, the SCSI BIOS startup message will appear for these boards in numerical order (PCI #1, PCI #2, PCI #3...).

6. The screen shows SCSI ID numbers used by the connected SCSI devices.

7. Upon completion of POST, the password entry screen appears prior to OS startup.

The password entry screen will appear after the normal termination of POST only if you have set a password in the BIOS setup utility “SETUP.”

You can enter a password up to three times. If you enter an incorrect password three times, the startup will be unsuccessful. In this case, turn off the power and then turn it on again after waiting 30 seconds to boot the server.

---

**IMPORTANT:**

Do not set a password before installing the OS.

---

8. Upon completion of POST, the OS will start up.

### Behavior at Occurrence of Error

If POST or OS startup does not finish normally, the server will reboot itself automatically.

At the time of reboot, it will select the other CPU/IO module and run POST or OS startup.

In this manner, the server retries POST or OS startup with different combinations of CPU/IO modules. If POST does not finish normally with any combinations, the server will stop with the state of DC OFF or Post end with an error message displayed.

While performing retries, the server displays or registers the error types.

For details of error messages, see Chapter 7 “Troubleshooting.”

### POST Error Messages

When the server detects an error during POST, it will notify you of the occurrence in the following manners:

- Displays an error message on the display unit.
- Makes a beeping sound.

These notification methods are described in “POST Error Messages” (Page 7-3).

---

**IMPORTANT:**

Before you contact your sales agent, write down the error messages and patterns of the beeping sound. They will serve as helpful information at the time of maintenance.

---

## CPU/IO Module Status

The CPU/IO module (#0 or #1) started first is managed as primary, and the module started later is managed as secondary. If one CPU/IO module is disconnected because of the failure and others, the other module becomes primary.

The CPU/IO module to be started first is selected depending on the primary/secondary status of modules when the server was shut down the last time.

The following devices are connected to the primary CPU/IO module by the hardware switch, although those can be connected to both CPU/IO modules #0 and #1. When one CPU/IO module is disconnected because of a failure, those are switched to the other module automatically and continue operating.

- VGA
- CD-ROM drive
- USB device (keyboard, mouse, floppy disk drive)

---

## Floppy Disk Drive (Option)

If you want to use a floppy disk drive with this server, connect N8460-002USB FDD UNIT, which are available optionally to a USB connector.

This server supports 3.5-inch 2HD (1.44 MB) and 2DD (720KB) floppy disks.

## Insert/Remove Floppy Disk

Before inserting a floppy disk into the drive, make sure that NEC Express5800/ft series is on (the POWER LED illuminates).

Insert a floppy disk into the drive firmly until it snaps in place. The eject button of the drive is then raised slightly.

---

### CHECK:

- You cannot use 1.2 MB-formatted disks.
  - If you insert an unformatted disk, you will see a message that the disk cannot be read or that needs formatting. To format a floppy disk, see your OS manual.
  - If you power on or restart NEC Express5800/ft series with a floppy disk left in the drive, the server will access the floppy disk to start the system. Unless a system exits on the FD, the server will be unable to start.
  - When using a USB floppy disk drive, the access to the floppy disk is delayed on rare occasions if the display graphic load is high because a moving picture is being played. In such a case, retry the operation with the floppy disk inside the floppy disk drive.
-

To remove a floppy disk from the drive, press the eject button.

---

**CHECK:**

Before removing a floppy disk, make sure that the floppy disk access LED is off. If you eject a floppy disk while the LED is on, the stored data could be damaged.

---

## Use of Floppy Disk

You may need to store important data on floppy disks. Since the floppy disk is a very delicate medium, you must handle it with extra care:

- Push the floppy disk gently into place.
- Attach the label on a proper position.
- Do not use a pencil or ballpoint pen to write on the floppy disk.
- Do not open the protective shutter.
- Do not use the floppy disk in a dusty place.
- Do not place anything on the floppy disk.
- Do not leave the floppy disk in a place that is subject to direct sunlight or high temperatures (e.g., near a heater).
- Keep away from cigarette smoke.
- Do not leave the floppy disk near water or chemicals.
- Keep away from magnetic objects.
- Do not clip disks. Be careful not to drop.
- Store floppy disks in a protective case where they are kept away from magnetic waves or dust.
- To prevent data from being erased accidentally, the floppy disk has a write-protect notch. When the disk is write-protected, you can read data, but you cannot write the data or format the disk. It is recommendable to write-protect floppy disks that contain important data except when you write data to the floppy disk. To write-protect a 3.5-inch floppy disk, slide the write-protect notch located on its back.

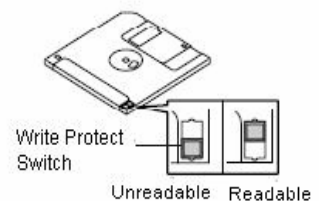

- The floppy disk is a very delicate storage medium. Dust or changes in temperature could cause data to be lost. Data loss could also be caused by faulty operation and computer trouble. To avoid such possible data loss, it is recommendable to back up important data regularly. (Be sure to make back-up copies of the floppy disks that are included with NEC Express5800/ft series.)

## CD-ROM Drive

NEC Express5800/ft series has a CD-ROM drive on the front panel. It is a device used to read data from a CD-ROM (compact disc read-only memory). Compared to a floppy disk, a CD-ROM allows for larger volume and fast data readout.

### ⚠ CAUTION



Observe the following instructions to use the server safely. There are risks of a burn, injury, or damage to physical assets. For details, see “PRECAUTIONS FOR SAFETY” in Chapter 1.

- Do not leave the CD tray ejected.

## Insert/Remove CD-ROM

Follow the steps below to set a CD-ROM.

1. Before you insert a CD-ROM, make sure that the server is powered on. When the server is powered on, the LED illuminates in green.
2. Press the CD-tray-eject button located in the front of the CD-ROM drive. The tray is then ejected.
3. Hold the CD-ROM with its signaling side facing the tray.

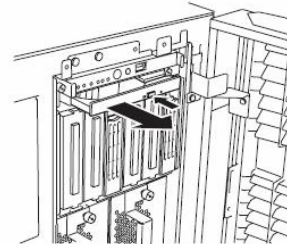

4. As shown in the figure on the right, place the CD-ROM on the tray and press lightly on the center to lock.

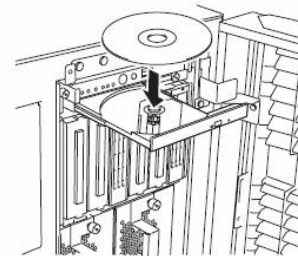

5. Push the front side of the tray gently to the drive-closed position.

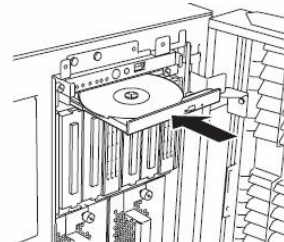

---

### IMPORTANT:

If you hear noise while running the CD-ROM drive, reset the CD-ROM.

---

To remove the CD-ROM, press the CD-tray-eject button as you did in setting the CD-ROM.

When the access LED illuminates in orange, it indicates the CD-ROM is being accessed. Make sure the access LED is not illuminating in orange before you press the CD-tray-eject button.

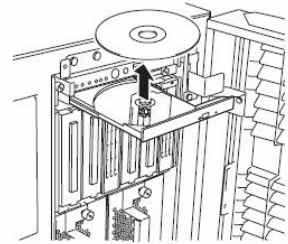

Press the locking part in the center of the tray and pick the CD-ROM gently. When you have removed the CD-ROM, push the tray to the drive-closed position.

### When you cannot eject a CD-ROM

When you cannot eject the CD-ROM from the server even by pressing the eject button, follow the steps below to eject it:

1. Press the POWER switch to power off this server (i.e. the POWER/SLEEP LED is off).
2. Use a metal pin of about 1.2 mm in diameter and 100 mm long (alternatively, you can use a fairly large paper clip after straightening). Insert it gently into the manual release hole located at the low front side of the server until the tray is ejected.

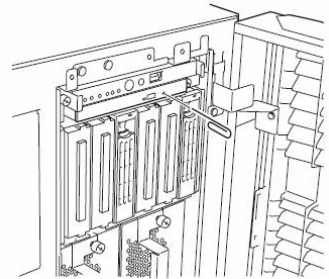

---

#### IMPORTANT:

- Do not use a toothpick, plastic pin, or other breakable objects.
  - If you cannot eject the CD-ROM by following the steps above, contact your sales agent.
- 

3. Hold the tray and pull it out.
4. Take out the CD-ROM.
5. Push the tray back.

## Handling CD-ROMs

Observe the following when you use a CD-ROM on NEC Express5800/ft series:

- As for a disk such as a noncompliant “copy-protected CD,” we shall not guarantee that you can use a CD player to play it with this server.
- Be careful not to drop the CD-ROM.
- Do not bend or place anything on the CD-ROM.
- Do not attach labels on the CD-ROM.
- Do not touch the signal side (blank side).
- Place the CD-ROM gently on the tray with the printed side up.
- Do not scratch, or use a pencil or ballpoint pen to write on the CD-ROM.
- Keep away from cigarette smoke.
- Do not leave the CD-ROM in a place that is subject to direct sunlight or high temperatures (e.g., due to a heater).
- If the CD-ROM gets dirty with dust or fingerprints, wipe it gently from its center to edge with a dry soft cloth.
- When you clean the CD-ROM, use a CD cleaner. Do not use a record cleaner (spray), benzine, or thinner.
- Store the CD-ROM in a protective case when not in use.



# Chapter 3

---

## Linux Setup and Operation

This chapter describes setup procedures to make NEC Express5800/ft series ready for use.

## HARD DISK CONFIGURATIONS THAT CAN BE BUILT ON THE NEC Express5800/ft series

In the NEC Express5800/ft series, all built-in disks need RAID configuration. Configure RAID 1 using software for the NEC Express5800/ft series.

The hard disks on the same slot location of the PCI module configure RAID. As shown in the following figure, hard disk drives in Slot 0 and Slot 3, Slot 1 and Slot 4, Slot 2 and Slot 5 should be paired to configure RAID.

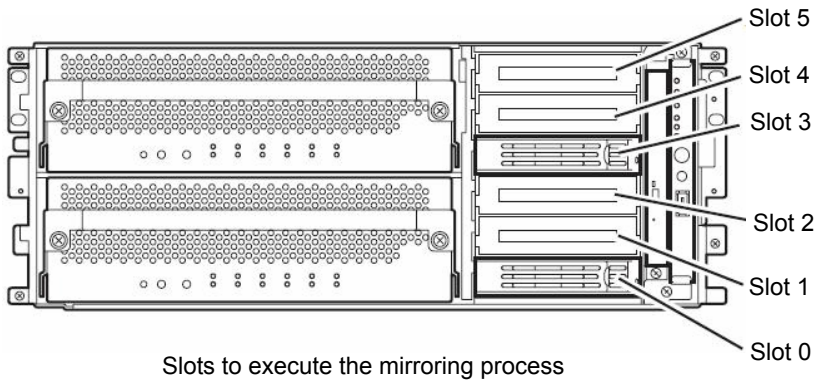

---

### IMPORTANT:

When adding disks or reconfiguring RAID, the status of each disk becomes “resync” or “recovery.” Do not insert/remove disks, turn off the power, or restart the system during this status. Wait until the status of “resync” or “recovery” is finished. You can check the status of RAID using `fdiskadm` described later. For details, see the separate volume of User’s Guide (Setup).

Two hard disk drives which configure RAID 1 must have the same disk capacity. Also, two hard disk drives must have the same logical structure.

---

Perform operations for built-in SCSI disks, such as mounting a disk, to devices (`md`) for RAID by software.

With the standard configuration at the time of shipment, the boot disks are inserted to the Slot 0 and Slot 3.

## REPLACING 3.5-INCH HARD DISK DRIVE

Follow the procedure below to remove the failed hard disk. If the hard disk fails, it should be replaced with new device with the server powered-on.

### How to Locate Failed Disks

This section describes a procedure to locate failed disks.

1. Open [Data Viewer] from ESMPRO Manager.

If trouble occurs, the color changes from green to red.

In this case, you will notice that there is trouble with both the SCSI Enclosures (ID: 41) and (ID: 42).

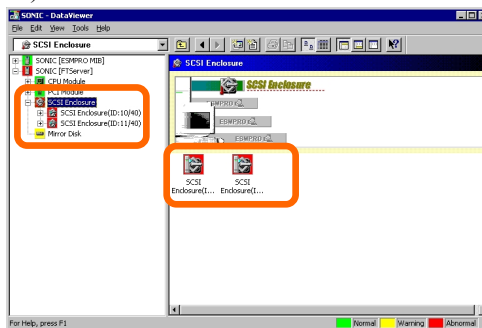

2. Check the SCSI Enclosures (ID: 41) and (ID: 42) on the tree.

See the path information in [General Information] of [SCSI Slot] to locate a group of 3.5-inch hard disk drive bays that corresponds to each enclosure.

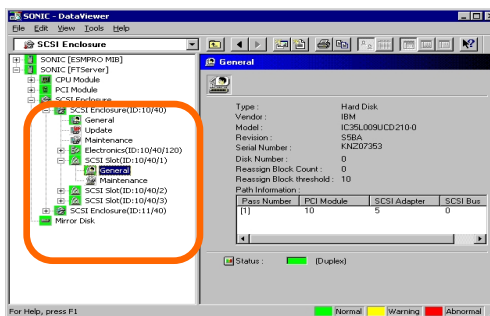

The table below shows the path information on Groups 1 and 2:

Slot	PCI module	SCSI adapter	SCSI bus
Group1	10	5	0
Group2	11	5	0

3. See the path information in [General Information] of [SCSI Slot (ID: 41/1)].

It shows that PCI module, SCSI adapter, and SCSI bus are 10, 5, and 0, respectively.

Pass Number	PCI Module	SCSI Adapter	SCSI Bus
[1]	10	5	0

This allows you to find that SCSI Slot (ID: 41/1) belongs to Group 1. SCSI slots under SCSI Enclosure (ID: 41) correspond to Group 1. Therefore, Group 2 corresponds to SCSI slots under SCSI Enclosure (ID: 42).

You will find that the failed disk located in the SCSI slot (ID: 41/2) is the second disk of Group 1.

---

## Restoring Redundant Configuration Manually

This section describes procedure to change the built-in disk on which failures occurred and re-establish the dual configuration of hard disks.

---

### IMPORTANT:

- Manual restoration of redundant configuration must be performed by a root user.
  - While recovery operation of RAID, the status of two disks configuring RAID become “resync” or “recovery” to build RAID for a while. Do not stop or restart the system until that status is finished.
  - Before recovering the boot disks (Slot0 and Slot3) from the system, remove the registration of the disk device that diskdump uses, and then register them again after the boot disks are recovered. Referring to “DUMP INITIALIZATION,” check the diskdump partition, remove the registration, initialize the disk dump partition, and register disk devices again.
- 
1. Select “RAID” – “Remove Half Disk” of ftdiskadm to separate the disk specified by the slot number from the RAID. For boot disks (Slot0 and Slot3), remove the registration of the disk devices that diskdump uses.
  2. Select “Bring Down” – “SCSI” of ftdiskadm to separate the disk specified by the slot number from the system.
  3. Remove the disk from the system and then insert a new disk.
  4. Select “Bring Up” – “SCSI” of ftdiskadm to add the disk specified by the slot number to the system.
  5. Use “Repair Disk” of ftdiskadm to recover RAID.

The following is an example from the separation of the built-in disk inserted to the slot 3 to the recovery. For boot disks (Slot0 and Slot3), initialize the disk partition and register the disk devices again after RAID is recovered.

### (Separating the disk from RAID)

```
#diskdumpctl -u /dev/hadb6
<<<For boot disks (Slot0 and Slot3), remove the registration of the
disk devices that diskdump uses.>>>

#ftdiskadm
Command Action
 1 => RAID
 2 => SCSI
 9 Quit

Command:2

Command Action
 1 New Disks
 2 Remove Half Disk
 3 Repair Disk
```

```

4 Remove Full Disks
5 Status(Raid)
6 Status(All Disks)
9 <= Return

Command:2

[Remove Half Disk]
Which scsi SLOT?[0-5]:3

mdadm: set /dev/hadb2 faulty in /dev/md1
mdadm: hot removed /dev/hadb2
mdadm: set /dev/hadb3 faulty in /dev/md2
mdadm: hot removed /dev/hadb3
mdadm: set /dev/hadb1 faulty in /dev/md0
mdadm: hot removed /dev/hadb1

Command Action
1 New Disks
2 Remove Half Disk
3 Repair Disk
4 Remove Full Disks
5 Status(Raid)
6 Status(All Disks)
9 <= Return

Command:5                <<<Confirm that the disk is disconnected from RAID>>>

[Status(Raid)]
Name Partition Status Member
-----
md1 /          simplex (0)hada2
md2           simplex (0)hada3
md0 /boot     simplex (0)hada1

Command Action
1 New Disks
2 Remove Half Disk
3 Repair Disk
4 Remove Full Disks
5 Status(Raid)
6 Status(All Disks)
9 <= Return

Command:9

```

(Disconnecting a disk from the system and adding a new disk)

```

Command Action
1 => RAID
2 => SCSI
9 Quit

Command:2

Command Action

```

```

1 Bring Down(System Disk)
2 Bring Up(System Disk)
3 Status(System Disks)
9 <= Return

Command:1

[Bring Down(System Disk)]
Which scsi SLOT?[0-5]:3

Command Action
1 Bring Down(System Disk)
2 Bring Up(System Disk)
3 Status(System Disks)
9 <= Return

Command:3 <<<Confirm that the disk is disconnected from the system>>>

[SCSI DISK STATUS]
-- SYSTEM --
slot name use serial path
0 hada 2 V3W1N8RA0050B5CL0399 h1c0t010ACT h7c0t010HOT
1 -
2 -
3 -
4 -
5 -
<<<Confirm that no disk is configured to the target slot and replace
the disk.>>>
<<<The following is an example of a RAID recovery procedure>>>
Command Action
1 Bring Down(System Disk)
2 Bring Up(System Disk)
3 Status(System Disks)
9 <= Return

Command:2

[Bring Up(System Disk)]
Which scsi SLOT?[0-5]:3

Command Action
1 Bring Down(System Disk)
2 Bring Up(System Disk)
3 Status(System Disks)
9 <= Return

Command:3 <<<Confirm that the disk is added to the system>>>

[SCSI DISK STATUS]
-- SYSTEM --
slot name use serial path
0 hada 2 V3W1N8RA0050B5CL0399 h1c0t010ACT h7c0t010HOT
1 -
2 -
3 hadb 0 V3W1RK5A0050B5CK040D h2c0t310ACT h8c0t310HOT
4 -

```

### 3-8 Linux Setup and Operation

---

```
5 -
Command Action
1 Bring Down(System Disk)
2 Bring Up(System Disk)
3 Status(System Disks)
9 <= Return
Command:9
```

#### (Restoring RAID)

```
Command Action
1 => RAID
2 => SCSI
9 Quit
Command:1
Command Action
1 New Disks
2 Remove Half Disk
3 Repair Disk
4 Remove Full Disks
5 Status(Raid)
6 Status(All Disks)
9 <= Return
Command:3
[Repair Disk]
Which scsi SLOT?[0-5]:3
Creating the partitions of /dev/hadb
mdadm: hot added /dev/hadb1
mdadm: hot added /dev/hadb2
mdadm: hot added /dev/hadb3
md0 is under repair.
Command Action
1 New Disks
2 Remove Half Disk
3 Repair Disk
4 Remove Full Disks
5 Status(Raid)
6 Status(All Disks)
9 <= Return
Command:5 <<< Confirm that the duplication process is started>>>
[Status(Raid)]
Name Partition Status Member
-----
md1 / resync=DELAYED (0)hada2 -(3)hadb2
md2 recovery55.8% (0)hada3 -(3)hadb3
md0 /boot duplex (0)hada1 (3)hadb1
```



```

<<<Perform recovery to each md device. After a while, use the following
command and check the status again.>>>

#service diskdmp initialformat
#diskdumpctl /dev/hadb6
<<<For boot disks (Slot0 and Slot3), initialize the diskdump partition
and register the disk devices again.>>>

Command Action
1 New Disks
2 Remove Half Disk
3 Repair Disk
4 Remove Full Disks
5 Status (Raid)
6 Status (All Disks)
9 <= Return

Command:5

[Status (Raid)]
Name Partition Status Member
-----
md1 / duplex (0)hada2 (3)hadb2
md2 /boot duplex (0)hada3 (3)hadb3
md0 /boot duplex (0)hada1 (3)hadb1

<<<If each md device's status is duplex, disk duplication is completed.>>>

```

**TIPS:**

- If you attempt to start `ftdiskadm` more than once at a time, “Cannot start” is displayed. If this message is displayed even when only one `ftdiskadm` is started, it may have been terminated without clearing the information. In such a case, run `ftdiskcleanup` and then start `ftdiskadm`.
- The trace log of `ftdiskadm` is recorded to the `/var/log/ftdiskadm` directory. If the files occupy a large part of the disk space, delete them from the oldest.
- Boot disks are inserted into the Slot0 and Slot3 normally. If you can only boot the system in the simplex mode, insert a boot disk into the Slot0 and boot the system.
- Use “RAID” - “Remove Full Disks” of `ftdiskadm` only when it is required because it deletes the md device from the system. To restore the deleted md device, the system needs to be restarted.

**IMPORTANT:**

Never use the command that directly deletes SCSI disk for separating a SCSI disk. If you do, RAID cannot be recovered when the deleted SCSI disk is included in the md device.

## SETTING THE VIDEO MODE

This section describes how to configure the video mode on the server. The server needs to be restarted in order to enable the video mode setting.

1. Log on with the root authority and open `/boot/grub/grub.conf` with an editor.

---

### IMPORTANT:

`grub.conf` is an extremely important file for the system.

In the worst case, you may not be able to start the system. Pay extra attention when editing the file.

---

2. Change the following setting within `grub.conf`. (The information shown below such as the kernel version “2.6.9-34.17AXsmp” is just an example, and it may be different from what is actually displayed in your environment. In such a case, read it as the information displayed in your environment.)

```
title Asianux HAS (2.6.9-34.17AXsmp)
  root (hd0,0)
  kernel /vmlinuz-2.6.9-34.17AXsmp ro root=/dev/md1 vga=0x323 video=vesafb:off
  initrd /initrd-2.6.9-34.17AXsmp.HAS.img
```

(1)

- (1) `vga=0x323` (0x323 is an option)

Configure the video mode common to the console and X server.  
Specify an appropriate value from the table below.

Value	Screen size	Color
0x317	1024 x 768	16bpp
0x318	1024 x 768	24bpp
0x323	1024 x 768	32bpp
0x314	800 x 600	16bpp
0x315	800 x 600	24bpp
0x31A	1280 x 1024	16bpp
0x31B	1280 x 1024	24bpp

It is recommended to set 0x317, 0x318, or 0x323. If other value is specified and the monitor does not support it, the screen may not be displayed properly.

3. Restart the server.

---

## Notes

- X server that supports the ft feature always operates in the same video mode as the console.
- The Xrandr feature is not supported. You cannot change screen resolution from X server.
- “IPMI Management Utility” cannot be used.
- “OpenIPMI” cannot be used.
- For using X on the console, run the system at the run level 5 and perform graphical logon. If X is not started at the system startup (run level 3), log on as root and enter “init 5” to the command line on thte text console to start X.

## DUMP INITIALIZATION

### 1. Checking partition for diskdump

#### 1-1. Check /var/crash (Dump file storage area)

```
# df
Filesystem      1K-blocks      Used    Available Use%    Mounted on
/dev/md1        40313912    5152136  33113896  14%    /
/dev/md0         194366      17729    166602  10%    /boot
none           1035356         0    1035356   0%    /dev/shm
/dev/md3       10080364   1089312  8478988  12%    /var/crash
```

Note: Unless you have created /var/crash partition, it does not exist. The dump file will be created on the partition that the root file system exists.

#### 1-2. Check diskdump partition (Dump file creation area)

```
#fdisk /dev/md*
```

Run “p print the partition table.”

- \* When HAS is loaded, run it at “fdisk /dev/had\*.”
- \* Check that dump partitions exist as many as the disks in fdisk.

Device	Boot	Start	End	Blocks	Id	System
/dev/hada1		1	25	200781	fd	Linux raid autodetect
/dev/hada2		26	5124	40957717+	fd	Linux raid autodetect
/dev/hada3		5125	5379	2048287+	fd	Linux raid autodetect
/dev/hada4		5380	8899	28274400	5	Extended
/dev/hada5		5380	6654	10241406	fd	Linux raid autodetect
/dev/hada6		6655	7929	10241406	83	Linux

Check the partition which is created for diskdump and the ID is 83.

In this example hada6 is the dump partition.

Note: If 1-1 and 1-2 do not exist, reinstall the OS. Create a dump partition in the phase of partition creation during installation.

### 2. Initializing the diskdump partition

#### 2-1. Edit /etc/sysconfig/diskdump

Open the file in:

```
#vi /etc/sysconfig/diskdump
```

and then add:

```
DEVICE=/dev/hada6:/dev/hadb6
```

and comment out other lines.

For had\*, specify the value of the partition you checked in 1-2.

- \* Even when the disk is expanded, this file needs to be edited.

## **2-2. Restart the dump partition**

Run the following command to reboot the dump driver.

```
# /etc/init.d/diskdump restart
```

## **3. Formatting the dump partition**

Run the following command to format the dump partition.

```
# /etc/init.d/diskdump initialformat
```

## **4. Registering a device to diskdump or removing it**

### **4-1. Register a dump driver**

```
# /usr/sbin/diskdumpctl /dev/hada6
```

### **4-2. Remove a dump driver**

Run the following command to reboot the dump driver.

```
# /usr/sbin/diskdumpctl -u /dev/hada6
```

## KEYBOARD SETTINGS FOR X WINDOW SYSTEM

The keyboard for X Window System is set to Japanese by default. (Keyboard model: jp106, Keyboard layout: jp)

If you use a non-Japanese keyboard, follow the procedure below to change your keyboard settings.

1. Open “/etc/X11/xgem.conf” on an editor.

```
Section "InputDevice"
# Specify which keyboard LEDs can be user-controlled (eg, with xset(1))
#       Option "Xleds"        "1 2 3"

# To disable the XKEYBOARD extension, uncomment XkbDisable.
#       Option "XkbDisable"

# To customize the XKB settings to suit your keyboard, modify the
# lines below (which are the defaults).  For example, for a non-U.S.
# keyboard, you will probably want to use:
#       Option "XkbModel"      "pc102"
# If you have a US Microsoft Natural keyboard, you can use:
#       Option "XkbModel"      "microsoft"
#
# Then to change the language, change the Layout setting.
# For example, a german layout can be obtained with:
#       Option "XkbLayout"     "de"
# or:
#       Option "XkbLayout"     "de"
#       Option "XkbVariant"    "nodeadkeys"
#
# If you'd like to switch the positions of your capslock and
# control keys, use:
#       Option "XkbOptions"     "ctrl:swapcaps"
# Or if you just want both to be control, use:
#       Option "XkbOptions"     "ctrl:nocaps"
#
#       Identifier "Keyboard0"
#       Driver      "kbd"
#       Option      ""XkbModel" "jp106"
```

```
       Option      ""XkbLayout" "jp""
```

```
EndSection
```

2. Change the underlined values on the previous page to those below. The settings may vary depending on the keyboard you use.

<For US keyboard>

[Before changed]

Option "XkbModel" "jp106"

Option "XkbLayout" "jp"

[After changed]

Option "XkbModel" "us101"

Option "XkbLayout" "us"

<For the same setting as text console>

[Before changed]

Option "XkbModel" "jp106"

Option "XkbLayout" "jp"

[After changed]

Option "XkbDisable"

3. Restart X Window System (with **Ctrl + Alt + BackSpace**) after changing the settings.

---

**IMPORTANT:**

- Change only the underlined sections. If you change the "Screen" section, the setting of X Window System may become incorrect.
-

## ACCESSING USB FDD

Access USB FDD after the device is mounted.

[How to mount]

```
# mount /media/floppy
```

---

**TIPS:**

If mount point is not automatically created, the service needs to be started again.

Run the following commands sequentially to start the service:

```
/etc/init.d/messagebus restart
```

```
/etc/init.d/haldaemon restart
```

---

---

### Notes

When accessing USB FDD by directly specifying the sd device name as in the example below, the device name may be changed if the system is disconnected or connected, and the data on partitions of other disks may be corrupted unintentionally.

[Example]

When commands are run on USB FDD after connecting the system by using the same sd device name as the one specified before it was disconnected, data on the partition of the disk A may be corrupted.

How the sd device name changes:

	Disk A	USB FDD	Disk B
Before disconnecting the system	sda	sdb	sdc
After disconnecting the system	none	sda	sdc
After connecting the system	sdb	sda	sdc

1) Before disconnecting the system:

```
# tar cf /dev/sdb files
```

→ Files are written in USB FDD.

2) After connecting the system

```
# tar cf /dev/sdb files
```

Files are written into the disk A unintentionally → Partitions are corrupted

---

**CHECK:**

It is a specification of the NEC Express5800/ft series to change the device name of the device file when incorporating and disconnecting the system.

---



# Chapter 4

---

## System Configuration

This chapter describes Basic Input Output System (BIOS) configuration.

When you install the Express5800 fault tolerant server for the first time or install/remove optional devices, thoroughly read this chapter for better understanding and correct setups.

## SYSTEM BIOS ~ SETUP ~

The SETUP utility is provided to make basic hardware configuration for the server. This utility is pre-installed in the flash memory of the server and ready to run.

The server is configured with the correct parameters using the SETUP utility and shipped in the best conditions. Thus, you do not need to use the SETUP utility in most cases. However, you might wish to use the SETUP utility in the cases described below.

---

### **IMPORTANT:**

- The SETUP utility is intended for system Administrator use only.
  - The SETUP utility allows you to set a password. The server is provided with two levels of password: Supervisor and User. With the Supervisor password, you can view and change all system parameters of the SETUP utility. With the User password, system parameters available for viewing and changing are limited.
  - Do not set any password before installing the OS.
  - The server contains the latest version of the SETUP utility. Dialog boxes appearing on your SETUP utility, thus, may differ from descriptions in this User's Guide. If you find anything unclear, see the online help or ask your sales agent.
-

---

## Starting SETUP Utility

Powering on the server starts POST (Power On Self-Test) and displays its check results. If the NEC logo is displayed, press **Esc**.

After a few seconds, either of the following messages appears at bottom left on the screen depending on your system configuration.

Press <F2> to enter SETUP

Press <F2> to enter SETUP or Press <F12> to boot from Network

You may see either of the following messages at bottom left on the screen when POST terminates.

Press <F1> to resume, <F2> to SETUP

Press **F2** to start the SETUP utility and display its Main menu.

If you have previously set a password with the SETUP utility, the password entry screen appears. Enter the password.

Enter password:[                    ]

Up to three password entries will be accepted. If you fail to enter the password correctly for three consecutive times, the server halts. (You can no longer proceed.) Power off the server.

---

### TIPS:

The server is provided with two levels of password: Supervisor and User. With the Supervisor password, you can view and change all system configurations. With the User password, the system configurations you can view or change are limited.

---

## Description of On-Screen Items and Key Usage

Use the following keyboard keys to work with the SETUP utility. (Key functions are also listed at the bottom of the screen.)

Shows the current menu.

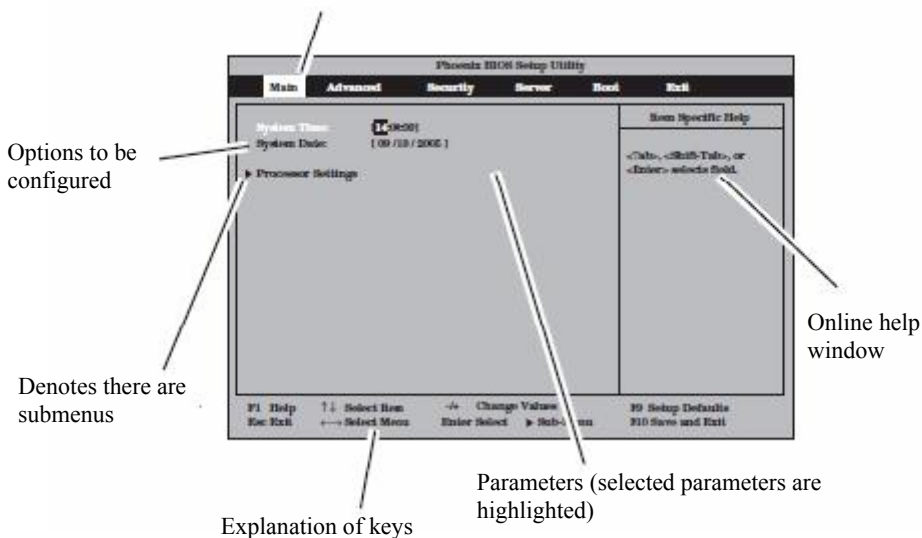

- Cursor** (↑, ↓): Selects an item on the screen. The highlighted item is currently selected.
- Cursor** (←, →): Selects the Main, Advanced, Security, System Hardware, Boot, or Exit menu.
- : Changes the value (parameter) of the selected item to the previous value.
- +**: Changes the value (parameter) of the selected item to next value.
- Enter**: Displays a submenu or chooses the selected parameter.
- Esc**: Displays the previous screen.
- F1**: Press **F1** when you need help on SETUP operations. The help screen for SETUP operations appears. Press **Esc** to return to the previous screen.
- F9**: Shows the following:

Setup Confirmation  
 Load default configuration now?  
 [Yes] [No]

If you select “Yes” and then press the **Enter** key, all items in the setup are set to default values. If you select “No” and then press either the **Enter** or **Esc** key, the status before pressing the **F9** key is restored.

**F10:**

Shows the following:

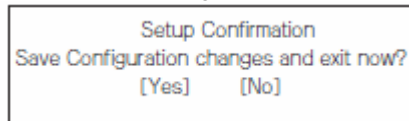
A screenshot of a dialog box titled "Setup Confirmation". The text inside the box reads "Save Configuration changes and exit now?" followed by two options: "[Yes]" and "[No]".

```
Setup Confirmation
Save Configuration changes and exit now?
[Yes] [No]
```

If you select “Yes” and then press the **Enter** key, the setup will complete with all changes you have made saved. If you select “No” and then press either the **Enter** or **Esc** key, the status before pressing the **F10** key is restored.

---

## Configuration Examples

The following describes examples of configuration required to use software-link features or for system operations.

### Link with Management Software

To control power supply of the server with NEC ESMPRO Manager via the network

<Using the LAN connector on the motherboard>

Select [Advanced]→ [Advanced Chipset Control]→ [Wake On LAN]→ [Enabled]

<Using the PCI LAN card>

Select [Advanced]→ [Advanced Chipset Control]→ [Wake On PME]→ [Enabled]

### UPS

To link power supply with the UPS

- To power on the server when power is supplied from the UPS  
Select [Server] - [AC-LINK] - [Power On].
- To keep the server off-powered even when power is supplied from the UPS if the POWER switch was used to power off  
Select [Server] - [AC-LINK] - [Last State].
- To keep the server off-powered even when power is supplied from the UPS  
Select [Server] - [AC-LINK] - [StayOff].

### Keyboard

To set Num Lock and key repeat

Select [Advanced] - [NumLock].

## Security

To set passwords on the BIOS level

Select [Security] - [Set Supervisor Password] and enter a password.

Set Supervisor password first, then User password.

To enable/disable the POWER switch

Select [Security] - [Switch Inhibit] - [Disabled]. (POWER switch enabled)

Select [Security] - [Switch Inhibit] - [Enabled]. (POWER switch disabled)

---

### IMPORTANT:

Masking the POWER switch disables forced shutdown as well as power on/off using the POWER switch.

---

## Optional PCI-related devices

To enable Option ROM of the PCI card (option) installed on the server

Select [Advanced] - [PCI Configuration] - [PCI Slot n] - [Option rom] - [Enabled].

n: Slot number to install the board

## Boot

To change the boot order of devices connected to the server

Select [Boot] and specify the boot order.

To display POST check results

Select [Advanced] - [Boot-time Diagnostic Screen] - [Enabled].

You can also press **Esc** while the NEC log is on the screen to display POST check results.

To control from the HW console

- Remote operation via LAN

Select [Server] - [Console Redirection], and make necessary settings.

## Memory

To check the installed memory (DIMM) status:

Select [Advanced] - [Memory Configuration] and check the status indications.

## **Saving the Configuration Data**

To save the BIOS configuration data

Select [Exit] - [Exit Saving Changes]

To discard changes to the BIOS configuration data

Select [Exit] - [Exit Discarding Changes]

To restore the default BIOS configuration data (the data may differ from the factory-setting)

Select [Exit] - [Load Setup Defaults].



## Menu and Parameter Descriptions

The SETUP utility has the following six major menus:

- Main
- Advanced
- Security
- Server
- Boot
- Exit

To configure detailed settings of functions, select a submenu from the above menus. Below describes configurable functions and parameters and the factory settings displayed in the screen for each menu.

### Main

Start the SETUP utility to display the Main menu.

When you select a menu with the “▶” mark and press the **Enter** key, its submenu appears.

<Example>

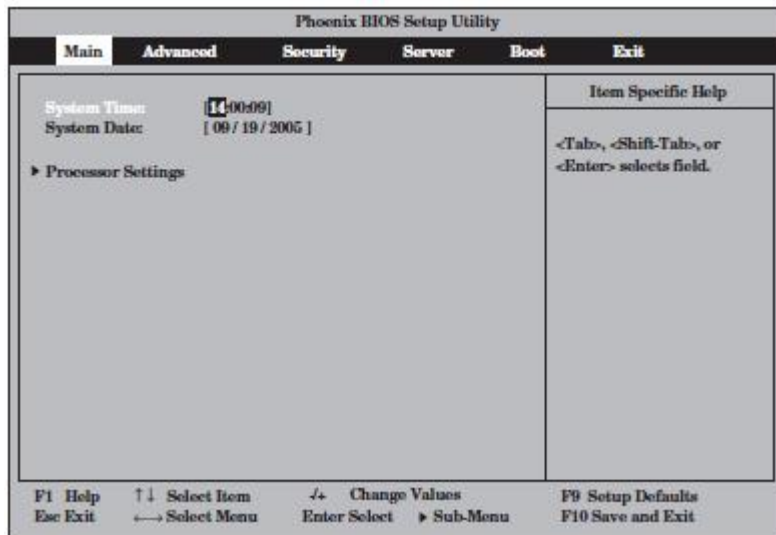

Available options in the Main and descriptions are listed below.

Option	Parameter	Description
System Time	HH:MM:SS	Specify the system time.
System Date	MM/DD/YYYY	Specify the system date.

[ ] factory - set

---

**IMPORTANT:**

Check and adjust the system clock before operation in the following conditions.

- After transporting the equipment
- After storing the equipment
- After the equipment halt under the conditions which is out of the guaranteed environment conditions (Temperature: 10 to 35°C, Humidity: 20 to 80%).

Check the system clock once in a month. It is recommended to operate the system clock using a time server (NTP server) if it is installed on the system which requires high level of time accuracy. If the system clock goes out of alignment remarkably as time goes by, though the system clock adjustment is performed, contact your sales agent.

---

## Processor Settings

Phoenix BIOS Setup Utility	
Main	
Processor Settings	Item Specific Help
Processor Speed Setting: 1.60 GHz	Set the processor MTRR register continuous or discrete for cache setting.
Processor 1 CPUID: 0F43	
Processor 1 L2 Cache: 2048 KB	
Processor 2 CPUID: 0F43	
Processor 2 L2 Cache: 2048 KB	
Execute Disable Bit: [Disabled]	
Cache Setting: [Continuous]	
F1 Help    ↑↓ Select Item    +/- Change Values    F9 Setup Defaults Esc Exit   ←→ Select Menu    Enter Select    ► Sub-Menu    F10 Save and Exit	

When you select “Processor Settings” in the Main menu, the following screen appears.

Refer to the table below for information on options.

Option	Parameter	Description
Processor Speed Setting	—	Displays the speed of the processor.
Processor 1 CPUID	CPUID	When the processor 1 is installed, its CPU ID is displayed. If the system supports "Hyper-Threading Technology," the ID of a physical processor but not logical processor appears here.
Processor 1 L2 Cache	—	Displays the cache size of the L2 of the processor 1.
Processor 2 CPUID	CPUID [Not Installed]	When the processor 2 is installed, its CPU ID is displayed. If it the processor is not installed, "Not Installed" appears.
Processor 2 L2 Cache	—	Displays the caches size of the L2 of the processor 2.
Execute Disable Bit	[Disabled] Enabled	Specify whether or not to enable the Execute Disable Bit feature.
Cache Setting	[Continuous] Discrete	Change the MTRR setting of the processor. If it takes time to display screen, set “Discrete.”

[ ]: Factory-set

## Advanced

Move the cursor onto "Advanced" to display the Advanced menu.

There is no configurable item on the Advanced menu screen below. Display each sub menu and make settings on the sub menu screen. Select an option with the "▶" mark and press **Enter** to display its submenu.

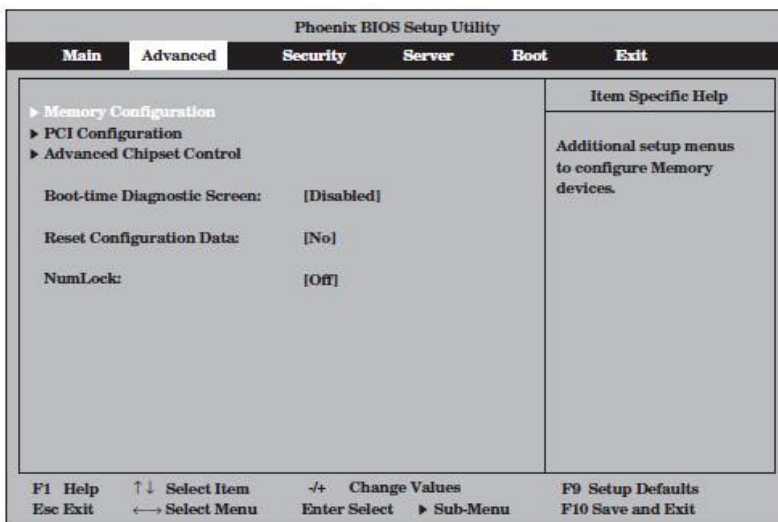

See the table below for setup options on the screen.

Option	Parameter	Description	Your Setting
Boot-time Diagnostic Screen	[Disabled] Enabled	Specify whether to display the Power On Self-Test (POST) screen at start-up. If "Disabled" is selected, the NEC logo appears while POST is in progress. (To display POST check results, press <b>Esc</b> and <b>F2</b> .) If "Console Redirection" is set to "Enabled," this option is unconditionally set to "Enabled."	
Reset Configuration Date	[No] Yes	If you select [Yes], the system configuration data will be cleared at next boot with this option set automatically to [No].	
NumLock	On [Off]	Specify whether or not to enable NumLock at system startup.	

[ ]: Factory-set

## Memory Configuration

When you select “Memory Configuration” in the Advanced menu, the following screen appears.

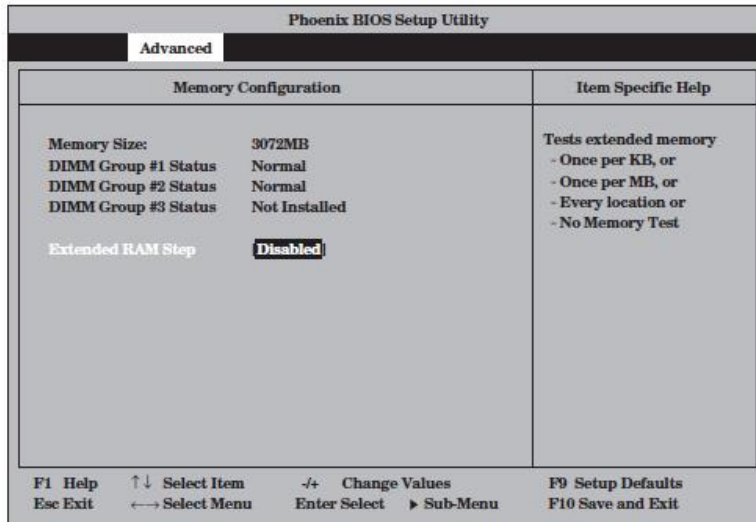

Refer to the table below for information on options.

Option	Parameter	Description
Memory Size	=	Displays the memory size.
DIMM Group #1 Status	Normal [Not Installed]	Displays the memory status.
DIMM Group #2 Status	Normal [Not Installed]	Displays the memory status.
DIMM Group #3 Status	Normal [Not Installed]	Displays the memory status.
Extended RAM Step	1MB 1KB Every location [Disabled]	Set the time interval between memory tests. Depending on the mounted memory amount, it may take about several tens of minutes to several hours to complete the test. Set “Disabled” for normal operation.

[    ]: Factory-set

## PCI Configuration

When you select “PCI Configuration” in the Advanced menu, the following screen appears. If you select a menu with the “▶” mark and press **Enter**, its submenu appears.

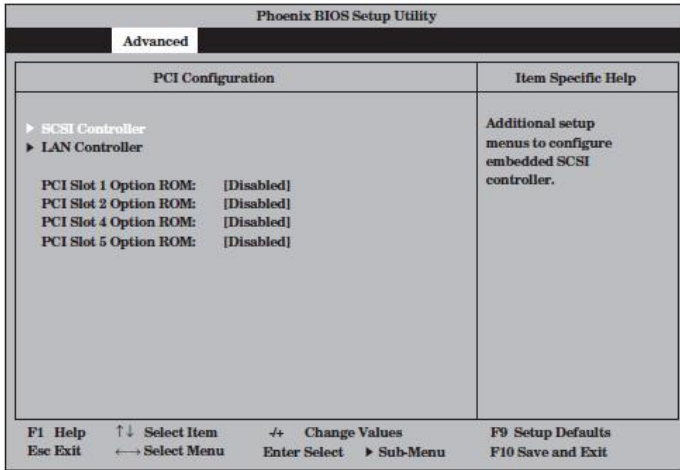

Refer to the table below for information on options.

Option	Parameter	Description
PCI Slot 1 Option ROM	Enabled [Disabled]	If [Enabled] is selected, the extended ROM of the slot device will be initialized.
PCI Slot 2 Option ROM	Enabled [Disabled]	
PCI Slot 3 Option ROM*	Enabled [Disabled]	

[ ]: Factory-set

\* Not provided for the 320Fb-L and 320Fb-LR models.

## SCSI Controller

When you select “SCSI Controller” in the Advanced menu, the following screen appears.

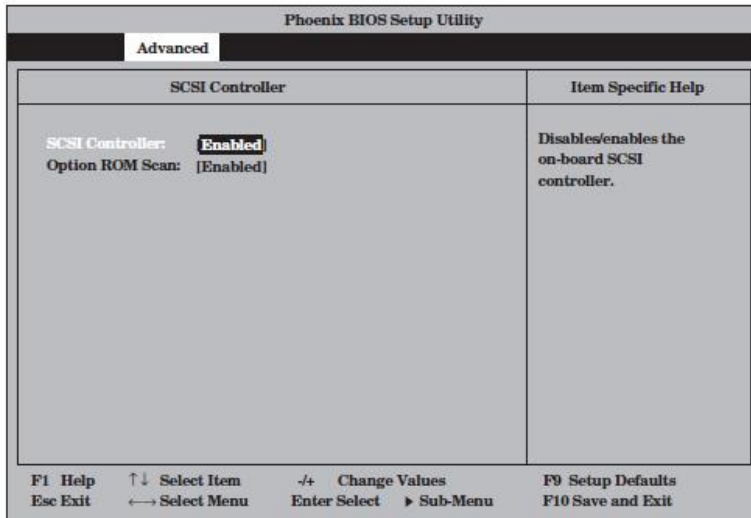

Refer to the table below for information on options.

Option	Parameter	Description
SCSI Controller	[Enabled] Disabled	If “Disabled” is selected, chip stays in the reset status. In this status, the SCSI Controller is totally disabled and not recognized by the PnP OS.
Option ROM Scan	[Enabled] Disabled	If “Enabled” is selected, the extended ROM of the device will be initialized.

[ ]: Factory-set

## LAN Controller

When you select “LAN Controller” in the Advanced menu, the following screen appears.

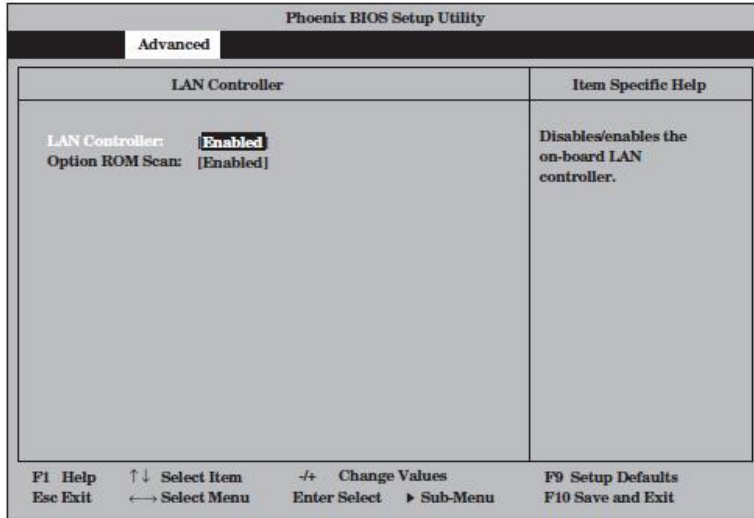

Refer to the table below for information on options.

Option	Parameter	Description
LAN Controller	[Enabled] Disabled	If “Disabled” is selected, chip stays in the reset status. In this status, the LAN Controller is totally disabled and not recognized by the PnP OS.
Option ROM Scan	[Enabled] Disabled	If “Enabled” is selected, the extended ROM of the device will be initialized.

[ ]: Factory-set



## Advanced Chipset Control

When you select “Advanced Chipset Control” in the Advanced menu, the following screen appears.

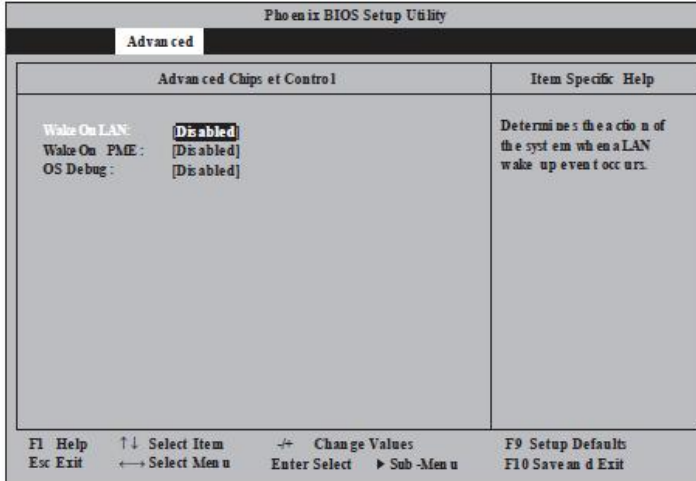

Refer to the table below for information on options.

Option	Parameter	Description
Wake on LAN	[Disabled] Enabled	Select whether or not to enable the remote power-on function via the LAN connector on motherboard.
Wake On PME	[Disabled] Enabled	Select whether or not to enable the remote power-on function via the PCI LAN card.
OS Debug	[Disabled] Enabled	Select whether or not to enable the OS Debug mode. Typically, select Disable.

[ ]: Factory-set

## Security

Move the cursor onto "Security" to display the Security menu.

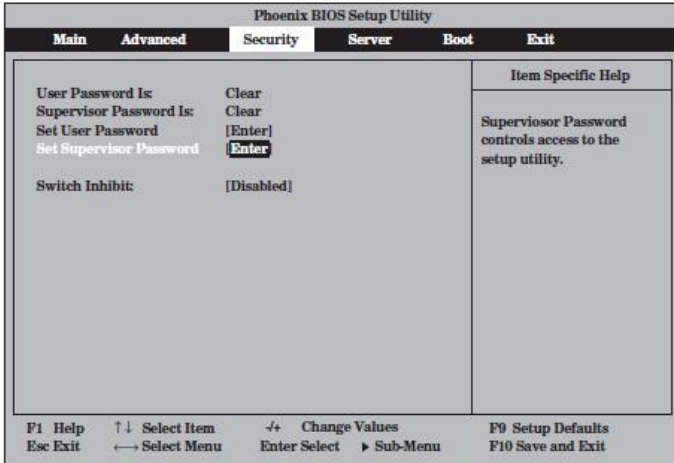

Select "Set Supervisor Password" or "Set User Password" and press **Enter** to display the following pop-up screen. The screen below shows when "Set Supervisor Password" is selected.

Set a password on this pop-up screen. Enter a password of up to seven alphanumeric characters and symbols from the keyboard.

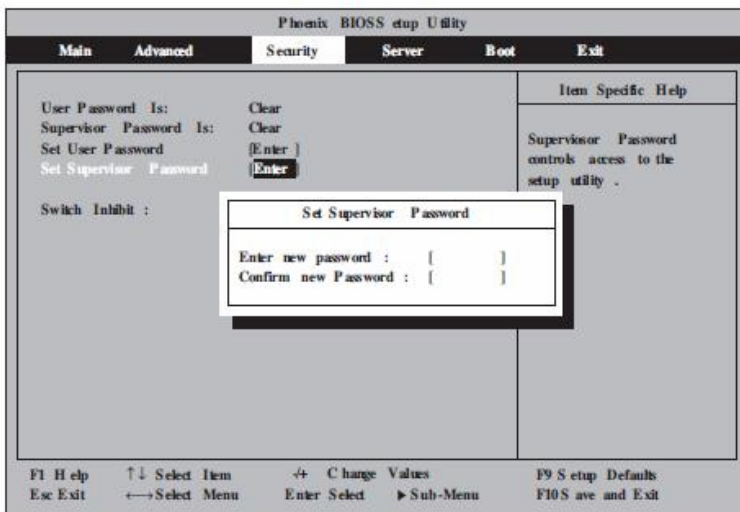

### IMPORTANT:

- User password setup is not available before Supervisor password setup.
- Do not set any password before installing the OS.
- If you forget your password, contact your sales agent.

See the table below for setup options on the screen.

Option	Parameter	Description
User Password is	[Clear] Set	Indicates User password setup status (view only).
Supervisor Password is	[Clear] Set	Indicates User password setup status (view only).
Set User Password	[Enter]	Press <b>Enter</b> to display the user password entry screen. With a user password, accessing the SETUP menus is restricted. This option is available only if the Supervisor Password is specified.
Set Supervisor Password	[Enter]	Press <b>Enter</b> to display the supervisor password entry screen. This option is available only when you log into the SETUP utility with the supervisor password.
Password on boot	[Disabled] Enabled	Specify whether to request a password entry at boot-up. User password setup is required beforehand.
Switch Inhibit	[Disabled] Enabled	Enable or disable the POWER switch on the server. If you select to enable, the switch will be disabled.

[ ]: Factory-set

---

**IMPORTANT:**

If you have logged in SETUP by using the Supervisor Password, you can check and change all settings. If you have logged in SETUP by using UserPassword, you see the settings but cannot make changes on the settings except System Time, System Date and User Password of Main.

---

## Server

Move the cursor onto [Server] to display the Server menu.

The following describes options you can configure in the Server menu and their functions. Select an option with the "►" mark and press **Enter** to display its submenu.

Refer to the table below for information on options.

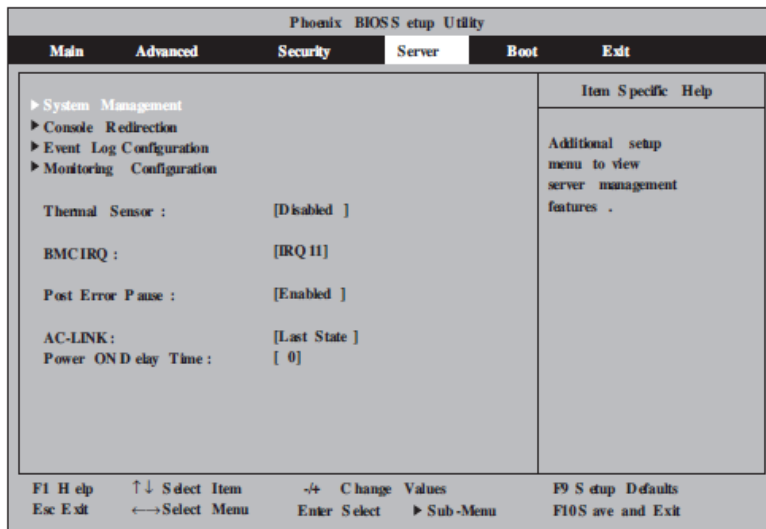

Option	Parameter	Description
Thermal Sensor	[Disabled] Enabled	Enable or disable the thermal sensor functions.
BMC IRQ	Disabled [IRQ 11]	Set the IRQ of BMC interruption.
Post Error Pause	[Disabled] Enabled	Set whether or not to pause POST at the end of POST if an error has occurred during POST execution.
AC LINK	Stay Off [Last State] Power On	Specify the AC LINK feature by selecting the status of the power supply unit of the server when the AC power supply restarts. (See the table on the next page for details.)
Power ON Delay Time	[0]-255	Configure the DC ON delay time if AC LINK is set to "Power On" or "Last State" (unit: second).

[ ]: Factory-set

\* "Console Redirection" is shown only when the N8815-001/001A ft Remote Management Card is installed.

The table below lists how selections for "AC LINK" determine the power status of the server when the power supply to the server restarts.

State before powered off	Parameter		
	Stay Off	Last State	Power On
In service	Off	On	On
Out of service (DC power: Off)	Off	Off	On
Forced shutdown *	Off	Off	On

\* Pressing the POWER switch for over four seconds shuts down the power to the server.

## System Management

Select "System Management" on the Server menu and press **Enter** to display the following screen.

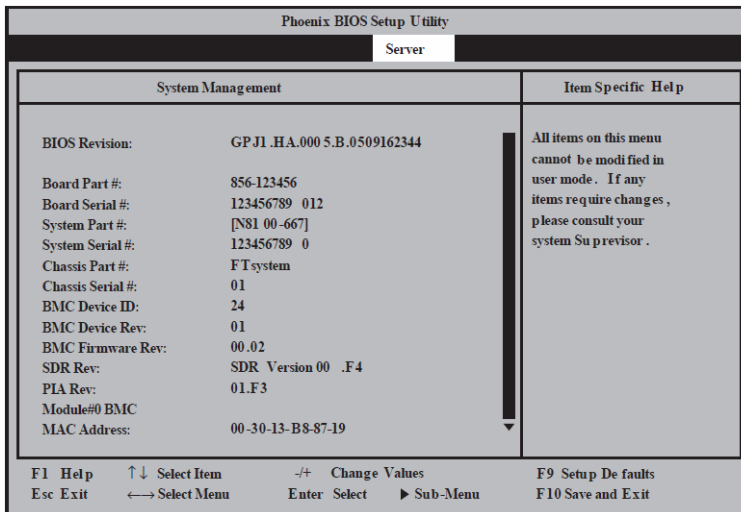

See the table below for setup options on the screen.

Option	Parameter	Description
BIOS Revision	—	Displays the BIOS revision.
Board Part Number	—	Displays the board information.
Board Serial Number	—	Displays the board information.
System Part Number	—	Displays the system information.
System Serial Number	—	Displays the system information.
Chassis Part Number	—	Displays the chassis information.
Chassis Serial Number	—	Displays the chassis information.
BMC Device ID	—	Displays the BMC information.
BMC Device Revision	—	Displays the BMC information.

Option	Parameter	Description
BMC Firmware Revision	—	Displays the BMC information.
SDR Revision	—	Displays the revision of SDR (sensor device information).
PIA Revision	—	Displays the PIA (plat form information) revision.
Module#0 BMC MAC Address*	—	Displays the BMC MAC address of CPU/IO module#0.
Module#1 BMC MAC Address*	—	Displays the BMC MAC address of CPU/IO module#1.

[ ]: Factory-set

\* MAC address information is shown only when the N8815-001/001A ft Remote Management Card is installed.

### Console Redirection

Select "Console Redirection" on the System Hardware menu and press **Enter** to display the following screen.

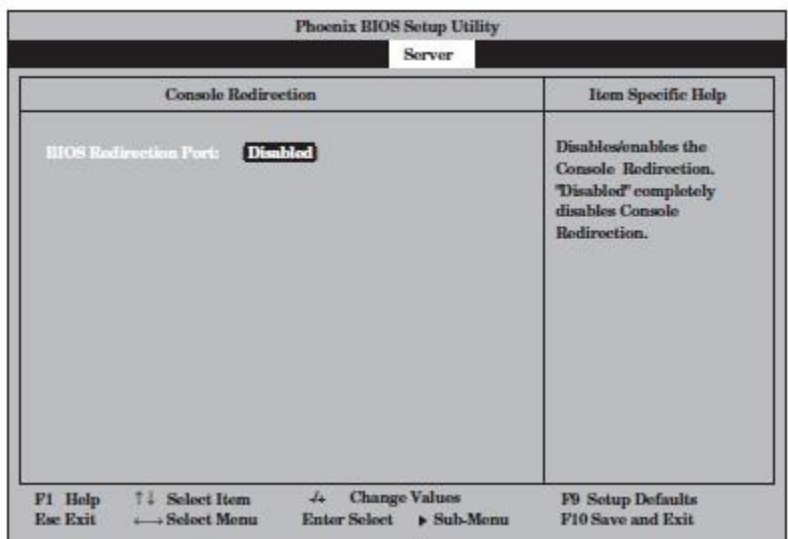

See the table below for setup options on the screen.

Option	Parameter	Description
BIOS Redirection Port	[Disabled] Enabled	Enable or disable Console Redirection. By enabling this option, you can remotely control behavior during POST.
Baud Rate*	9600 [19.2K] 38.4K 57.6K 115.2K	Select a port rate used for the interface with a hardware console to be connected.

---

Option	Parameter	Description
Flow Control*	[None] XON/XOFF [CTS/RTS] CTS/RTS+ CD	Select a flow control method.
Console Type*	PC-ANSI [VT100+] VT-UTF8	Select a console type.

[ ]: Factory-set

\* Displayed only when the BIOS Redirection Port menu is enabled.

## Event Log Configuration

Select "Event log Configuration" on the System Hardware menu and press **Enter** to display the following screen.

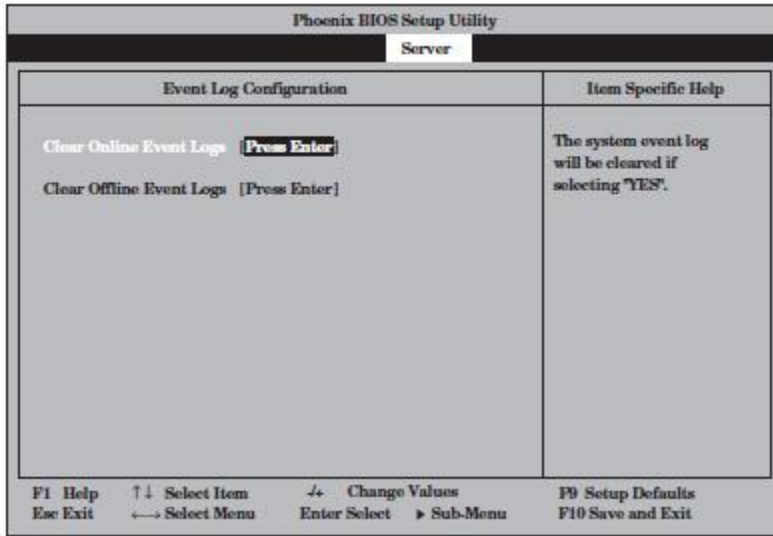

See the table below for setup options on the screen.

Option	Parameter	Description
Clear Online Event Logs	[Press Enter]	To clear event logs of the working module, press the <b>Enter</b> key and select "Yes."
Clear Offline Event Logs	[Press Enter]	To clear event logs of the stand-by module, press the <b>Enter</b> key and select "Yes."



## Monitoring Configuration

Select “monitoring Configuration” on the Server menu and press **Enter** to display the following screen.

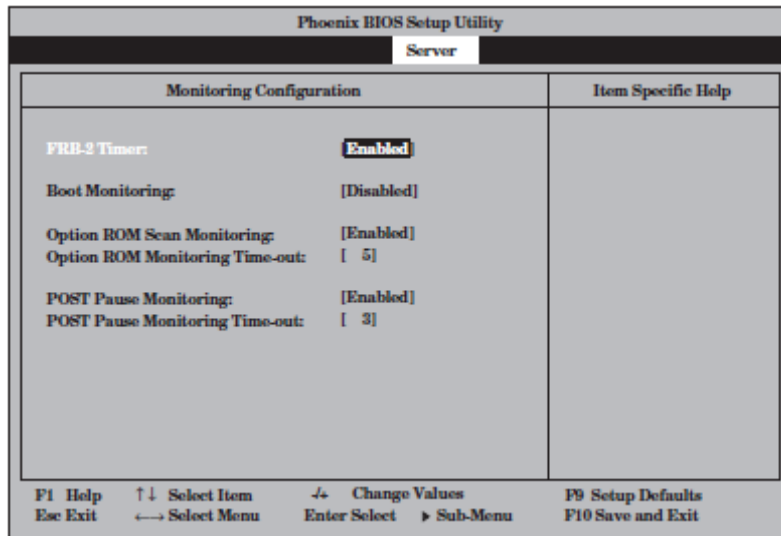

Option	Parameter	Description
FRB-2 timer	Disabled [Enabled]	Select whether or not to enable the FRB-2 timer.
Boot Monitoring	Disabled 5 minutes [10 minutes] 15 minutes 20 minutes 25 minutes 30 minutes 35 minutes 40 minutes 45 minutes 50 minutes 55 minutes 60 minutes	Select whether or not to enable the timer for boot monitoring at startup. If you are starting up from an OS with no NEC ESMPRO Agent installed, disable this option. If you use Disaster Recovery Option for ARCserve, select [Disabled].
Option ROM Scan Monitoring	Disabled [Enabled]	Select whether or not to enable the function to monitor the option ROM scan.
Option ROM Monitoring Time-out	1-[5]-20	Set the timeout of the option ROM scan. This option is displayed when the Option ROM Scan menu is set to [Enabled] (unit: minute).
POST Pause Monitoring	Disabled [Enabled]	Set whether or not to enable the POST monitoring function during boot pause.
POST Pause Monitoring Time-out	1-[3]-20	Set the time for POST monitoring during boot pause. This option is displayed when the POST Pause Monitoring menu is set to [Enabled] (unit: minute).

[ ]: Factory-set

## Boot

Move the cursor onto "Boot" to display the Boot menu.

The server searches for the boot device according to the order specified in this menu and use the software to boot the system if found.

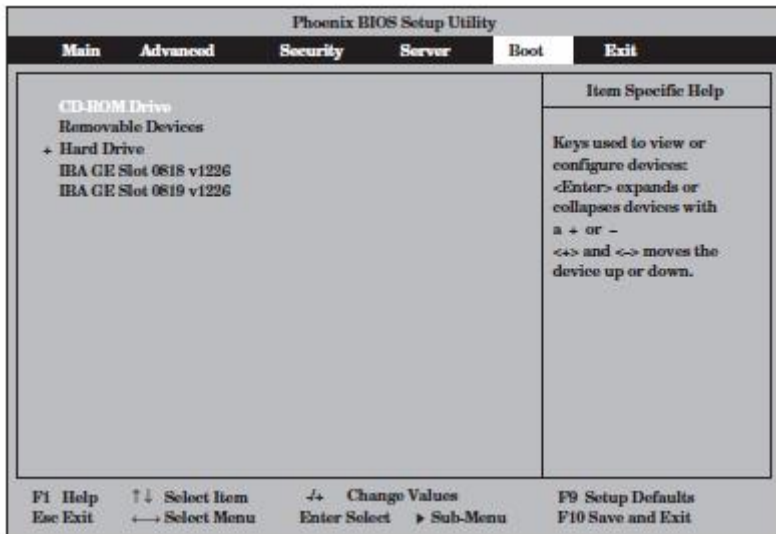

You can change the boot device order using ↑ or ↓ and + or -. Move the cursor to select the device by ↑ or ↓, and then change the priority using + or -.

---

### IMPORTANT:

Specify the device boot order as shown above to start the NEC EXPRESSBUILDER.

---

## Exit

Move the cursor onto "Exit" to display the Exit menu.

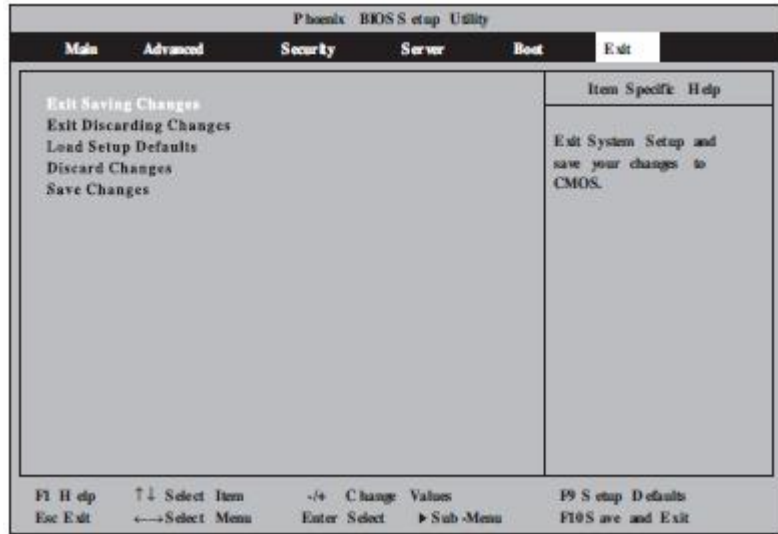

The following describes each option on the Exit menu:

### Exit Saving Changes

Select this option to save the current configuration data into the CMOS (non-volatile memory) and exit the SETUP utility.

Select “Exit Saving Changes” to display the right screen. Select "Yes" to save the current configuration data into the CMOS (non-volatile memory) and exit the SETUP utility. The server will automatically restart the system.

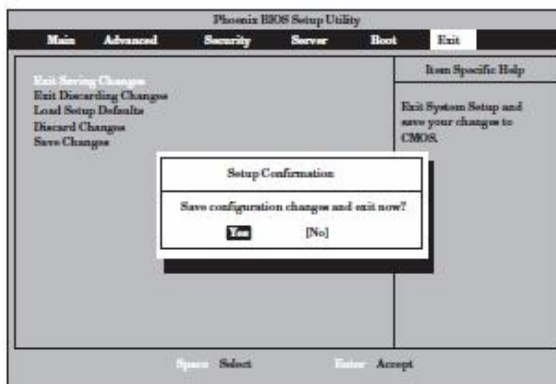

### Exit Discarding Changes

Select this option to exit the SETUP utility without saving the current configuration data into the CMOS (non-volatile memory).

If you select “Yes” here, the “SETUP Warning” dialogue box appears. If you select “No” in the “SETUP Warning” dialogue box, you can exit SETUP without saving the changes you have made.

If you select “Yes” in the dialogue box, you can exit SETUP with the changes you have made saved in CMOS. The server reboots automatically.

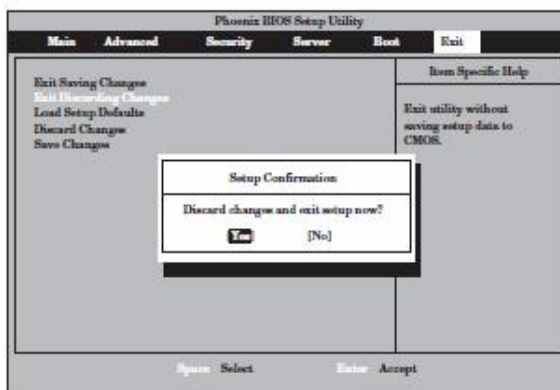

### Load Setup Defaults

Select this option if you want to reset all values in SETUP to default (factory-set values). When you select Load Setup Defaults, the dialogue box as shown on the right appears.

If you select “Yes” in the dialogue box, default values are restored. If you select “No,” you will see the Exit menu screen.

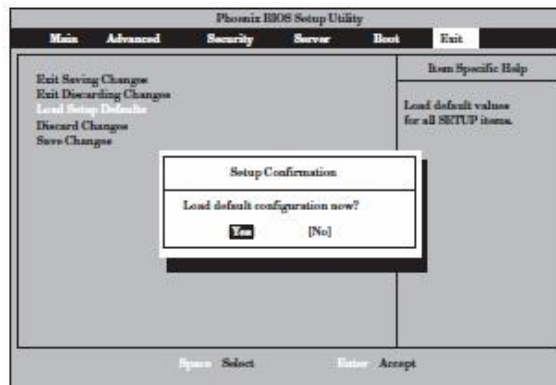

#### **IMPORTANT:**

The default value slightly differs from the factory-set value. Check all setting values before restoring the default value.

### Discard Changes

Select this option if you want to restore previous values before saving values in CMOS. When you select “Discard Changes,” you will see the dialogue box as shown on the right. If you select “Yes” in the dialogue box, changes you have made are discarded and previous settings are restored.

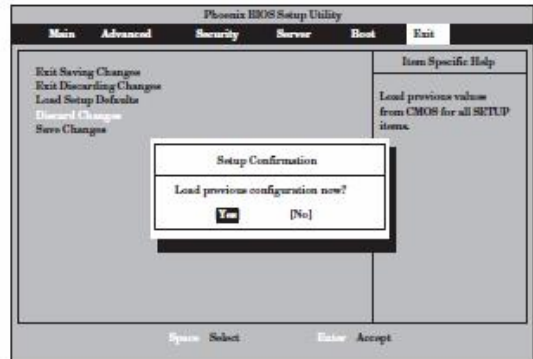

### Save Changes

Select this option if you want to save changes you have made in CMOS (non-volatile memory) without exiting SETUP. When you select the Save Changes, you will see the dialogue box as shown on the right. If you select “Yes” in the dialogue box, changes you have made are saved in CMOS (non-volatile memory).

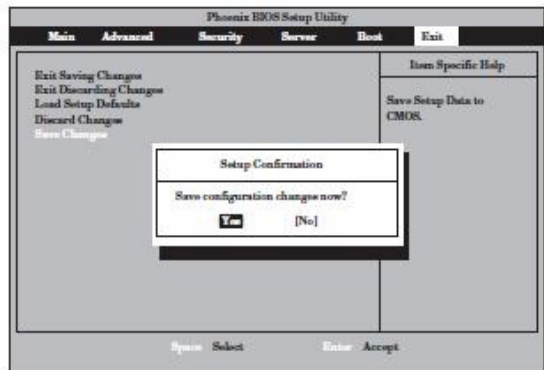

---

## SCSI BIOS (SCSISelect)

The “SCSISelect” utility makes settings of the SCSI controller on a motherboard. You can start it up by simple key operation during POST execution without using any special startup disk.

---

### IMPORTANT:

Because the server is installed with the latest version of the SCSISelect utility, your screen display may be different from the one described in this guide. For information on options different from those described in this guide, refer to the online help or ask your service agent.

---

### Usage of the SCSISelect utility

The SCSISelect utility is activated when you configure the transfer speed of SCSI devices connected to the server (except hard disk drive), and allows you to make settings.

---

### IMPORTANT:

SCSI configuration must be set by starting up the utility on a SCSI controller basis. The server is equipped with one SCSI controller. If you have added SCSI controller boards, you need to make SCSI controller settings as many as the number of added SCSI controller boards in addition to the configuration for the built-in SCSI controller. The utility used for changing settings may be different.

---

### Starting and Quitting the SCSISelect utility

The following section describes the procedures from starting the SCSISelect utility to quitting the utility. For information on how you start up and/or operate the utility stored on the option board, see the manual shipped with the option board.

1. Power on the server.

The following message appears on the screen during POST execution.

---

### IMPORTANT:

The message is repeated for the number of times as many as the number of SCSI controllers installed.

---

```
Adaptec SCSI BIOS vX.XX
Copyright 2004 Adaptec, Inc. All Rights Reserved.

◀ ◀ ◀ Press <Ctrl> <N> for SCSISelect(TM) Utility! ▶ ▶ ▶
```

2. Press and hold down the **Ctrl** key and press the **N** key.

The SCSISelect utility starts up with the “Main” menu displayed.

3. Use the cursor to select a channel in the “Bus:Device” box, and then press the **Enter** key.



The SCSI controller of the motherboard has two channels.  
The channel A (08:01:00) shows the hard disk drive of ID0, ID1 and ID2 while the channel B (08:01:01) shows the hard disk drive of ID3, ID4 and ID5.  
When selection is made, the “Options” menu appears.

4. Select the Options menu and press the **Enter** key.



If you want to make settings of the adapter (selected channel) or the SCSI device connected to the channel, choose “Configure/View SCSI Controller Settings.”  
If you want to know or verify the format of hard disk drive or find the SCSI ID of the device connected to the channel, select “CSI Disk Utilities.”  
For more information, see the following description.

To quit *SCSISelect*, press the **Esc** until you see the closing message. (If any changes have been made, the message asking you whether or not to save the changes is displayed. Select Yes (save the changes) or No (discard the changes)).

## Configure/View SCSI Controller Settings

When you select “Configure/View Host Adapter Settings” in the “Options” menu, the following screen appears.

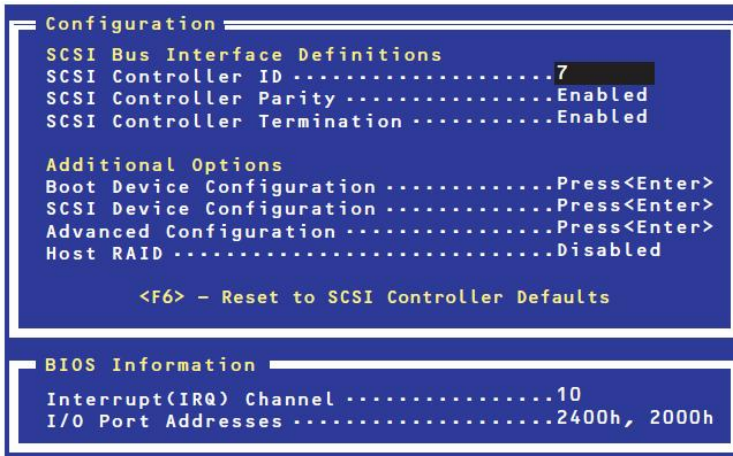

The following describes menus and parameters. Read the descriptions to optimize your system.

### SCSI Bus Interface Definitions

Use arrow keys to select SCSI BUS Interface Definitions. The following table provides information on options and their functions.

Option	Parameter	Function/settings
SCSI Controller ID	0 to [7] to 5	Set “7.”
SCSI Controller Parity	[Enabled] Disabled	Set “Enabled.”
SCSI Controller Termination	[Enabled] Disabled	This option allows you to select whether or not to enable the terminator. Set “Enabled.”

[ ]: Factory-set



## Additional Options

Use arrow keys to select Additional Options.

## Boot Device Configurations

When you select “Boot Device Configurations” and press the **Enter** key, the display changes as shown below:

```

Boot Device Configuration
-----
Single Image
Master SCSI Controller .....AIC-7902 A at slot 00 02:03:00
Select SCSI peripheral from which to boot.
Boot SCSI Controller .....AIC-7902 A at slot 00 02:03:00

```

## SCSI Device Configuration

When you select “SCSI Device Configuration” and press the **Enter** key, the display changes as shown below:

```

SCSI Device Configuration
-----
SCSI Device ID      #0  #1  #2  #3  #4  #5  #6  #7
Sync Transfer Rate (MB/Sec)....320 320 320 320 320 320 320 320
Packetized.....Yes Yes Yes Yes Yes Yes Yes Yes
QAS.....Yes Yes Yes Yes Yes Yes Yes Yes
Initiate Wide Negotiation.....Yes Yes Yes Yes Yes Yes Yes Yes
Enable Disconnection.....Yes Yes Yes Yes Yes Yes Yes Yes
Send Start Unit Command.....Yes Yes Yes Yes Yes Yes Yes Yes
BIOS Multiple LUN Support..... No No No No No No No No
Include in BIOS Scan.....Yes Yes Yes Yes Yes Yes Yes Yes

SCSI Device ID      #8  #9  #10 #11 #12 #13 #14 #15
Sync Transfer Rate (MB/Sec)....320 320 320 320 320 320 320 320
Packetized.....Yes Yes Yes Yes Yes Yes Yes Yes
QAS.....Yes Yes Yes Yes Yes Yes Yes Yes
Initiate Wide Negotiation.....Yes Yes Yes Yes Yes Yes Yes Yes
Enable Disconnection.....Yes Yes Yes Yes Yes Yes Yes Yes
Send Start Unit Command.....Yes Yes Yes Yes Yes Yes Yes Yes
BIOS Multiple LUN Support..... No No No No No No No No
Include in BIOS Scan.....Yes Yes Yes Yes Yes Yes Yes Yes

```

---

### IMPORTANT:

You can make settings on a SCSI ID basis. Before you make settings, confirm the SCSI ID of your target device.

---

### TIPS:

If you do not know the SCSI ID of the added option, choose “SCSI Disk Utilities” in the “Options” menu. After a while, the screen showing SCSI IDs and matching devices appears. For more information, see “SCSI Disk Utilities” described later.

---

The following table provides information on options and their functions on the menu.

Option	Parameter	Description
Sync Transfer Rate (MB/Sec)	[320] 33.3 160 20.0 80.0 10.0 66.6 ASYN 40.0	Typically, set "320." This value may need to be changed depending on the option connected. For more information, see the manual attached to the option.
Packetized	[Yes] No	Select whether or not to optimize the bus usage ratio by using the function to transfer packetized data (DT or dual transition).
QAS	[Yes] No	Select whether or not to use the Quick Arbitration and Selection(QAS) function, which improves the SCSI bus usage ratio
Initiate Wide Negotiation	[Yes] No	If the connected SCSI device supports Wide SCSI, select "Yes." If not, select "No."
Enable Disconnection	[Yes] No	Set "Yes."
Send Start Unit Command	[Yes] No	Set "Yes" for a hard disk drive. Otherwise set "No."
BIOS Multiple LUN Support	Yes [No]	Set "No."
Include in BIOS Scan	[Yes] No	Set "Yes."

[ ]: Factory-set

## Advanced Configuration

When you select “Advanced Configuration” and press the **Enter** key, the display changes as shown below:

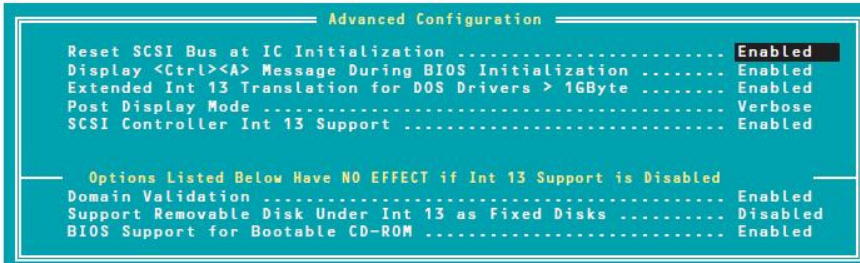

The following table provides information on options and their functions.

Option	Parameter	Description
Reset SCSI Bus at IC Initialization	[Enabled] Disabled	Set “Enabled.”
Display <Ctrl><Alt> Message During BIOS Initialization	[Enabled] Disabled	Set “Enabled.”
Extended Int 13 Transfer for DOS Drivers > 1 Gbyte	[Enabled] Disabled	Set “Enabled.”
Post Display Mode	[Verbose] Silent Diagnostic	Do not change the settings unless it is necessary.
SCSI Controller Int 13 Support	[Enabled] Disabled: NOT Scan Disabled: scan bus	Select whether or not to enable SCSI BIOS. Select “Enabled” except <ul style="list-style-type: none"> <li>when starting up the OS from a hard disk drive other than those connected to the SCSI controller (it is OK if no hard disk drive is connected to controller other than SCSI controller).</li> <li>when reserving a space in the extended ROM space. In this case, you can disable the BIOS of a SCSI controller to which no hard disk drive is connected.</li> </ul>
Domain Validation	[Enabled] Disabled	Set “Enabled.”
Support Removable Disks under Int 13 as Fixed Disks	Boot Only All Disks [Disabled]	Options controlled by removable media are supported by AIC-79xx BIOS.
BIOS Support for Bootable CD-ROM	[Enabled] Disabled	Set “Enabled.”

[ ]: Factory-set

## SCSI Disk Utilities

SCSI Disk Utilities scans a device connected to the selected channel and displays information on the device. If the device is a hard disk drive, you can perform low-level formatting or verification.

When you choose “SCSI Disk Utilities” in the “Options” menu, which is shown after selecting a channel to be configured, the screen for scanning SCSI IDs is displayed.

```
AIC-7902 A at slot ??, 02:03:00
Scanning SCSI ID: 4: LUN Number :0
```

After the scanning the screen showing SCSI IDs and corresponding devices appears.

```
Select SCSI Disk and press <Enter>
SCSI ID #0      : No device
SCSI ID #1      : No device
SCSI ID #2      : No device
SCSI ID #3      : No device
SCSI ID #4      : No device
SCSI ID #5      : No device
SCSI ID #6      : No device
SCSI ID #7      : Adaptec AIC - 7902
SCSI ID #8      : No device
SCSI ID #9      : No device
SCSI ID #10     : No device
SCSI ID #11     : No device
SCSI ID #12     : No device
SCSI ID #13     : No device
SCSI ID #14     : No device
SCSI ID #15     : No device
```

When you select a device on this screen and press the **Enter** key, details of the device is shown.

If the selected device is a hard disk drive, you can execute the following submenus.

- **Format Disk:** performs low-level formatting for the selected device
- **Verify Disk Media:** compares (verifies) all sectors of the selected device and if there is any bad sector, re-assignment will be performed.

---

## FORCED SHUTDOWN AND CLEAR

Read this section if your server does not operate as expected, or if you want to return all setup values to those made at shipment.

---

### Forced Shutdown

Use this function when an OS command does not shut down the server, the POWER switch does not turn off the server, or resetting does not work.

Press and hold the POWER switch on the server for over four seconds. The power is forcibly turned off. To turn on the power back again, wait approximately 30 seconds after turning off the power (forced shutdown).

---

#### **IMPORTANT:**

If the remote power-on feature is used, power on the server and start the OS, and turn off the power in the normal way.

---

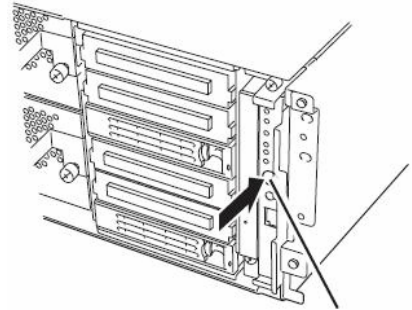

Press it for over 4 seconds.

## CLEAR CMOS/PASSWORD

With the pre-installed SETUP utility, you can set desired passwords to protect data stored on the server from unauthorized user access. If you forget the password, you can clear them by following the procedure described in this section.

You can also use the same procedure to clear the CMOS data in the server.

---

### IMPORTANT:

- Clearing the CMOS data restores the factory settings.
  - To clear the password or CMOS data, power off the server.
- 

To clear the password or the CMOS data, use configuration jumper pins (jumper switches) located inside of the server. The jumper switches are found on the motherboard in a CPU/IO module. See the figure below.

---

### IMPORTANT:

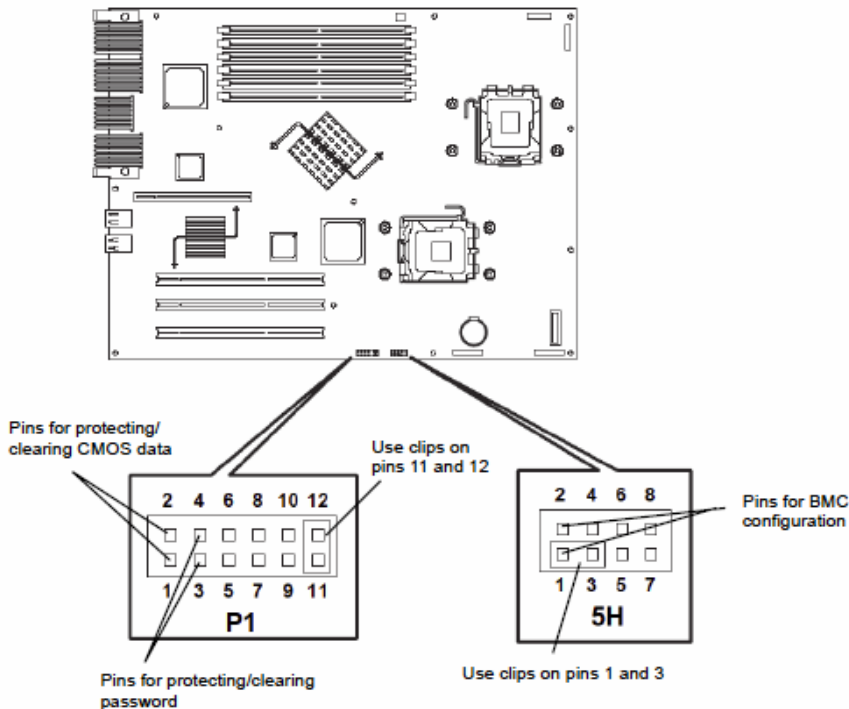

Do not change any other jumper switch settings. Any improper change may cause the server to fail or malfunction.

---



- Pins for protecting/clearing the password
  - Short-circuiting the two pins: Clears the password
  - Opening the two pins: Protects the password (factory-set)
- Pins for protecting/clearing the CMOS data
  - Short-circuiting the two pins: Clears the CMS data
  - Opening two pins: Protects the CMOS data (factory-set)

The following describe the clearing procedure.

 <b>WARNING</b>	
	<p>Observe the following instructions to use the server safely. There are risks of death or serious personal injury. See “PRECAUTIONS FOR SAFETY” in Chapter 1.</p> <ul style="list-style-type: none"> <li>■ Do not disassemble, repair, or alter the server.</li> </ul>

### How to Clear CMOS

1. Power off the NEC Express5800/ft series and unplug the both power cords.
2. Remove the both CPU/IO modules (#1 and #2) from the NEC Express5800/ft series (see “Removing CPU/IO Module” on page 8-17).
3. Make setting of jumper switch for clearing CMOS of CPU/IO # 0.  
Remove the clips from the jumper pins 11-12 and place them on the jumper pins 1-2 on the CPU/IO Module #1.
4. Mount only the CPU/IO Module # 0 to the NEC Express5800/ft series (see “Installing CPU/IO Module” on page 8-19).
5. Connect the power cord of the CPU/IO module #0 and press the POWER switch to power on.
6. When you see “8150: NVRAM Cleared By Jumper” and “Press <F1> to resume, <F2> to Setup” during POST after the startup, press the POWER switch to power off, and then disconnect the power cord from the outlet.

Example

-----  
Phoenix ServerBIOS 3 Release 6.0  
Copyright 1985-2003 Phoenix Technologies Ltd.  
All Rights Reserved  
GPJ1. HA. XXXX. X. XXXXXXXXXXXX  
IGPJ BIOS Release X. X  
Build Time: XX/XX/XX XX : XX : XX  
2x Intel (R) Xeon (R) CPU 3.60GHz  
3072M System RAM Passed  
2048K Cache SRAM Passed  
System BIOS shadowed  
Video BIOS shadowed  
IPMI Base Board Management Controller was detected.  
Device ID : XX Device Revision : XX  
IPMI Version : X. X Firmware Revision : XX. XX  
Self Test Result : XXXXH  
SMBIOS Initialize. . . . . Passed  
System Monitoring Check. Passed  
ERROR  
8150: NVRAM Cleared By Jumper  
Press <F1> to resume, <F2> to Setup  
-----

7. By referring to “Removing CPU/IO Module” on page 8-17, remove the CPU/IO module #0 from the server.
8. Restore the previous CMOS clear jumper switch settings. Remove the jumper pins 1-2 of the CPU/IO module #0 and install them on the jumper pins 7-8.
9. By referring to “Installing CPU/IO Module” on page 8-19, install the CPU/IO module #0 on the server.
10. Reconnect the power cord of the CPU/IO module #0 and press the POWER switch to power on.
11. After the startup, press the **F2** key during POST to start BIOS SETUP.
12. Make settings in SETUP as you desire and then the settings by selecting “Exit”→ “Exit Saving Changes.” Switch the power off and disconnect the power cord from the outlet.
13. Clear CMOS for the CPU/IO module #1 by following the steps 3 to 12.
14. By referring to “Installing CPU/IO Module” on page 8-19, install both CPU/IO modules on the server.
15. Connect both power cords.



## HOW TO CLEAR PASSWORDS

1. Power off NEC Express5800/ft series and unplug the both power cords.
2. Remove the both CPU/IO modules (#1 and #2) from the NEC Express5800/ft series (see “Removing CPU/IO Module” on page 8-17).
3. Make setting of jumper switch for clearing the password of CPU/IO module # 0...  
Remove the clips from the jumper pins 11-12 on CPU/IO module # 0 and place them on the jumper pins 3-4 on the CPU/IO Module #1.
4. Mount the CPU/IO Module # 0 to NEC Express5800/ft series (see “Installing CPU/IO Module” on page 8-19).
5. Connect the power cord of CPU/IO module #0 only, and then press the POWER switch to power on.
6. When you see “8151: Password Cleared By Jumper” and “Press <F1> to resume, <F2> to Setup” during POST after the startup, press the POWER switch to power off, and then disconnect the power cord from the outlet.

### Example

```

-----
Phoenix ServerBIOS 3 Release 6.0
Copyright 1985-2003 Phoenix Technologies Ltd.
All Rights Reserved
GPJ1. HA. XXXX. X. XXXXXXXXXXXX
IGPJ BIOS Release X. X
Build Time : XX/XX/XX XX : XX : XX
2x Intel (R) Xeon (R) CPU 3.60GHz
3072M System RAM Passed
2048K Cache SRAM Passed
System BIOS shadowed
Video BIOS shadowed
IPMI Base Board Management Controller was detected.
Device ID : XX Device Revision : XX
IPMI Version : X. X Firmware Revision : XX. XX
Self Test Result : XXXXH
SMBIOS Initialize. . . . . Passed
System Monitoring Check. Passed
ERROR
8151: NVRAM Cleared By Jumper
Press <F1> to resume, <F2> to Setup
-----

```

7. By referring to “Removing CPU/IO Module” on page 8-17, remove the CPU/IO module #0 from the server.
8. Reset the jumper switch setting.  
Remove the clips from the jumper pins 3-4 and place them on the jumper pins 11-12 on the CPU/IO Module # 0.
9. Clear password for the CPU/IO module #1 by following the steps 3 to 8.

- 10.** By referring to “Installing CPU/IO Module” on page 8-19, install both CPU/IO modules on the server.
- 11.** Connect both power cords.

## BMC Configuration Jumper Settings

You can restore the initial values of the BMC configuration information (logon name/password etc.), which are set when you use a remote management function. The values are registered on a CPU/IO module basis. Because of this, you need restore the values for your target CPU/IO module.

How to restore initial values:

1. Power off the server and then disconnect the power cords of both CPU/IO modules from the outlet
2. Remove your target CPU/IO module from the server by referring to "Removing CPU/IO Module" on page 8-17.
3. Make clear settings of the jumper for the BMC configuration of the CPU/IO module. Remove the CPU/IO module jumper pins (5H) 1-3 and set them to the jumper pins (5H) 1-2 (see page 4-38).
4. Install the CPU/IO module on the server by referring to "Installing CPU/IO Module" on page 8-19.
5. Connect the power cords of CPU/IO modules and wait for 30 seconds. Then disconnect the power cords of both CPU/IO modules from outlet again.
6. Remove your target CPU/IO module from the server by referring to "Removing CPU/IO Module" on page 8-19.
7. Restore the original statue of the jumper for the BMC configuration of the CPU/IO module. Remove the CPU/IO module jumper pins (5H) 1-2 and set them to the jumper pins (5H) 1-3.
8. Install the CPU/IO module on the server by referring to "Installing CPU/IO Module" on page 8-19.

---

### **IMPORTANT:**

By this operation, BMC settings required in NEC DianaScope or remote management functions for connection with the server will be cleared as well. If you are using NEC DianaScope, store the settings required to connect to NEC DianaScope in media such as a floppy disk before this operation, and configure the settings after the operation again. Use NEC DianaScope Agent or NEC EXPRESSBUILDER system management function to configure and save the BMC settings.

---

## REMOTE MANAGEMENT FUNCTION

320Fb-L and 320Fb-LR models are equipped with the optional card, N8815-001A Remote Management Card on the server. By connecting to a network via their management LAN port, BMC (Baseboard Management Controller), an LSI for system management, installed on the server allows remote monitoring and controlling of the server such as keyboard, video and mouse (KVM) control over management network.

---

### Network Default Values

The following are default values to connect the server to a network.

IP Address	: 192.168.1.1
User Name	: administrator
Password	: (None)
Host Name	: ARMXXXXXXXXXXXXXX

- The host name above is the host name used for auto registering with a DNS server using DHCP functions.  
XXXXXXXXXXXXXX is the MAC address assigned to each management card. The MAC address can be found on the label attached to the rear or the card or Server-System Management Sub-menu Selections- Primary BMC MAC Address/Secondary BMC MAC Address on the BIOS Set UP screen.

---

### IMPORTANT:

- The default IP address of the management LAN is 192.168.1.1 for both CPU/IO module #0 and CPU/IO module #1. Therefore, the server cannot connect to network at the same time without changing the IP address. To connect to network simultaneously, specify different IP addresses.
  - To ensure security, change values for host name, password and IP address according to your network environment.
- 

---

### Settings on the Server

The following describes the settings that should be made on the server to use the server.

---

#### CHECK:

The resolution and refresh rate of the screen that can be displayed on a remote KVM console are 1024x768 and 75Hz or smaller respectively. If values larger than these are set, the remote screen does not display any data. If a great value is set for the number of colors on the screen for the server, the remote may not show colors accurately. Connecting this card to a network where broadcast occurs frequently may affect remote control performance.

---

---

## Initial Settings on the Server

1. If information specific to the server has not been written in, the following message informing you that the server-specific information is not written is displayed while the NEC logo is displayed, and the startup processing of the server is paused.

If this message is not displayed, the remote management function does not need to be initialized. If it is displayed, the remote management function needs to be initialized in order to monitor devices into details.

H/W Configuration of BMC is corrupted.

!! Update BMC H/W Configuration by configuration tool !!

!! Refer to BMC configuration manual !!

The message above may appear in a different screen during POST with the NEC logo shown and paused. In that case, press the **Esc** key to display the diagnosis screen to check whether or not the above message is shown. If a different error message is shown, refer to Chapter 7 “Troubleshooting.”

2. How to make initial settings

Either wait for a while after the above message is shown or press the **F1** key to precede POST. Start up the “NEC EXPRESSBUILDER”CD-ROM and select “initialize Remote Management Card” from the Tool menu. By doing so, information specific to each server will be written in.

When writing the information is completed, the following message appears. Press any key to reboot the server for use.

Strike a key when ready...

---

### TIPS:

Running the initialize Remote Management Card resets the AC LINK setting (Server-AC LINK) of the BIOS setup to the initial value “Last State.” If you have changed the value, you will need to set it again.

---

---

## Setting a Management PC

The following provides management PC considerations to connect the server and a management PC.

### Setting Your Browser

Configure the following.

- Enable SSL.

### Supported browsers

The following browsers are supported.

- Microsoft Internet Explorer 6.0
- Netscape 7.0
- Mozilla 1.6

### Java2 Runtime Environment

Java2 Runtime Environment, Standard Edition 1.4.2\_04 or later is required.  
Follow the steps below if you use NEC EXPRESSBUILDER for installation:

- When the OS of the management PC is Windows:
  - (1) Activate Windows on the PC on which you want to install Java2 Runtime Environment and set the “NEC EXPRESSBUILDER” CD-ROM.
  - (2) By the auto startup function, the master control menu of NEC EXPRESSBUILDER appears. Click “Software Setup” and then “NEC DianaScope,” and then run the installer of JRE, which you find in the NEC DianaScope install menu.

- When the OS of the management PC is Linux:

The JRE installer (Linux) is stored in the following directory of the NEC EXPRESSBUILDER CD-ROM:

```
/dianascope/jre_x
```

For installing JRE, log on as root user or obtain the root authority by the su command.

- (1) Copy the JRE installer to any directory. Below is an example of copying the installer from the NEC EXPRESSBUILDER to /user/local/bin:

```
cp /mnt/cdrom/dianascope/jre_x/j2re-1_4_2_09-linux-i586.rpm.bin/usr/  
local/bin
```

- (2) Go to the directory where you copied the JRE installer. Below is an example that the installer was copied to /user/local/bin:

```
cd /user/local/bin
```

- (3) Extract the JRE installer.

```
./j2re-1_4_2_09-linux-i586.rpm.bin
```

- (4) Install JRE. JRE will be installed in the directory of each JRE version under /usr/java.

```
rpm -ivh ./j2re-1_4_2_09-linux-i586.rpm
```

- (5) Add an environment variable “JAVA\_HOME.” Enter the directory name that you installed JRE.

For bash:

```
export JAVA_HOME=/usr/java/j2re1.4.2_09
```

For tesh:

```
setenv JAVA_HOME=/usr/java/j2re1.4.2_09
```

- (6) Set the path to JRE.

For bash:

```
export PATH=$JAVA_HOME/bin:$PATH
```

For tesh:

```
setenv PATH $JAVA_HOME/bin:$PATH
```

---

### IMPORTANT:

For the Mozilla browser, create a symbolic link to the Java Plug-in in the Mozilla plugins directory.

---

- \* If you want to install the latest Java Runtime, download it from the following site. If you use NEC DianaScope on the same management PC, use Java2 Runtime Environment, which you can find in the “NEC EXPRESSBUILDER”CD-ROM.

<http://java.sun.com/j2se/>

If you access the logon page without installing Java2 Runtime Environment, the following message may appear. Check the message and perform installation.



---

## Using Remote Management

### Overview

You can control power of this server and use the remote KVM console from a web browser by using web server functions of BMC.

This function is achieved by Java Applet.

### How to get connected

From a Web browser on the management PC, access the following URL.

URL: [http://BMC\\_HostPort/index.htm](http://BMC_HostPort/index.htm)

---

#### TIPS:

- “BMC\_HostPort” is a BMC IP address or host name followed by a colon and http port number. If the http port number is 80 (the default value), you can omit the port number.
- 

#### When connecting to network which supports DHCP protocol:

The default host name of BMC is ARMC characters followed by the MAC address if you use DHCP functions and automatically register it with your DNS server.

IP Address	: 192.168.1.1
User Name	: administrator
Password	: (None)
Host Name	: <span style="border: 2px solid red; padding: 2px;">ARMCXXXXXXXXXXXXXX</span>

Default host

#### When connecting to network which does not support DHCP protocol:

- (1) The default IP address of the LAN of the managed server is “192.168.1.1” for both CPU/IP module #0 and #1. If you want to access the network that does not support DHCP protocol, access the network that the default IP address can use, and then set the IP address according to your network environment from the managing PC (see “BMC Configuration”).



- (2) If you cannot use the default IP “192.168.1.1,” start up the “NEC EXPRESSBUILDER” CD-ROM on the server and select [Tools] → [System Management] → [Set System Management Parameters] → [Configuration]. Select [New] to register new settings, or [Change] to change the settings. Then, set IP addresses of the managed LAN ports on the [BMC Configuration] menu.

LAN1: CPU/IO Module#0 management LAN port

LAN2: CPU/IO Module#1 management LAN port

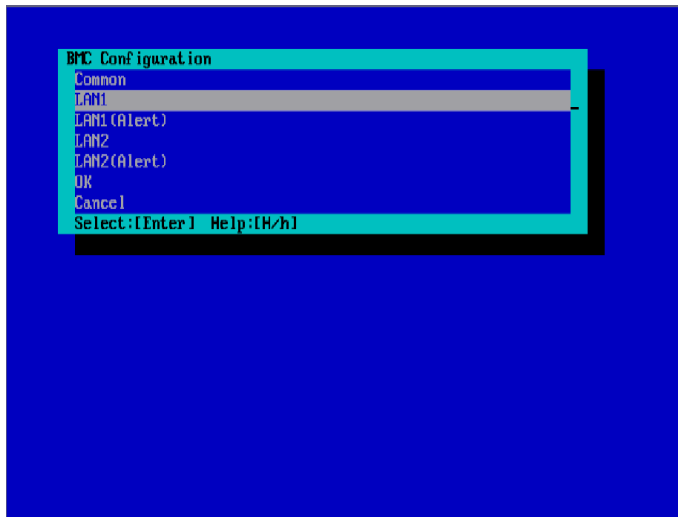

The following is a configuration screen for LAN1 (CPU/IO module #0). Specify an IP address to use. Make settings for LAN2 (CPU/IO module #1) in the same manner.

For the settings to take effect, you need to execute [OK] on the previous menu, “BMC Configuration” window.

Specify different IP addresses to LAN1 (CPU/IO module #0) and LAN2 (CPU/IO module #1).

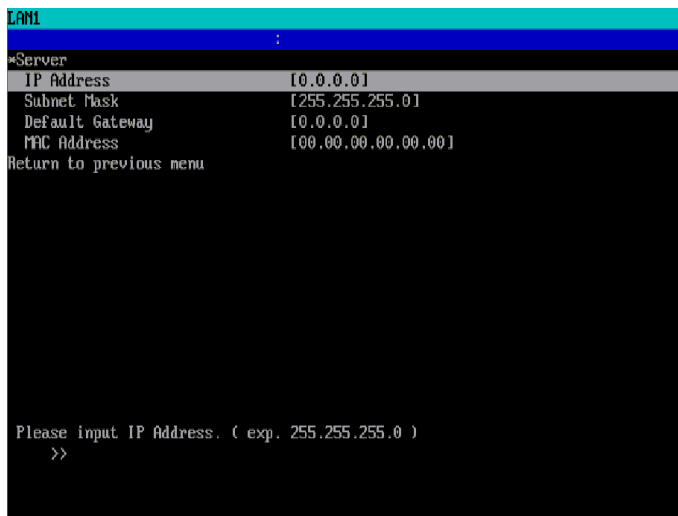

**TIPS:**

To disable the remote management console function, make the following settings from the NEC EXPRESSBUILDER CD-ROM. Load the NEC EXPRESSBUILDER CD-ROM on the server, and from the main menu, select [Tools] → [System Management] → [Set FT Remote Management Card (LAN1/LAN2)]. Select [Disable] on [Remote Management Console] and register the setting. The host name, the domain name, and the IP address cannot be modified on this screen.

The image below shows the setting screen for LAN1 (CPU/IO module #0).

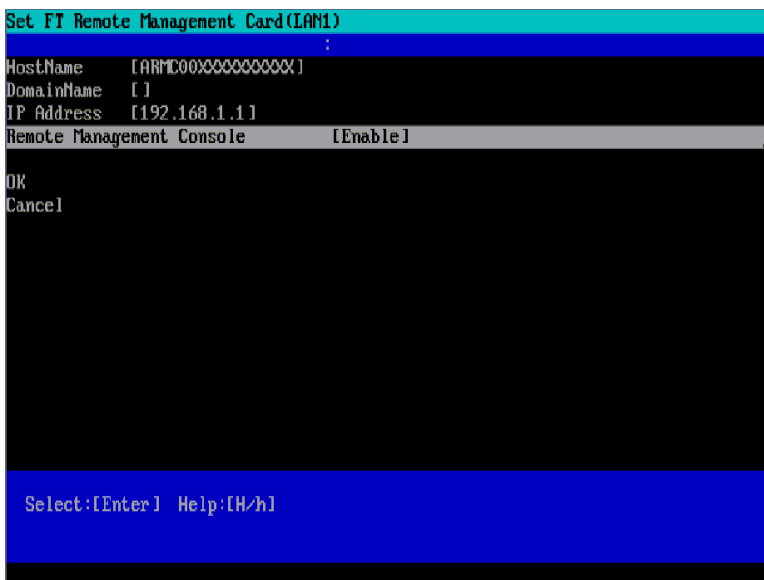

If you use remote management for the first time, the “Warning - Security” dialogue box as shown below may be displayed. Check the message, and then click [Yes] [No], or [Always]. Then you will see the logon page. If you are not sure, click [No].

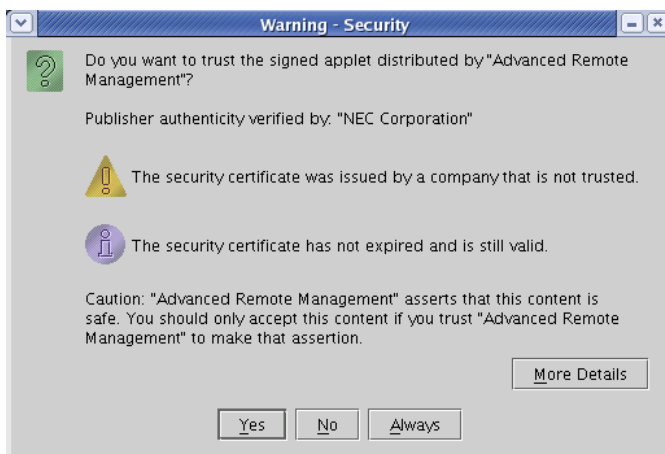

---

**TIPS:**

If you use SSL for access, the “Warning - Security” dialogue box(es) for server certification may be displayed for SSL in addition to the dialogue box shown above.

---

## Logon and logout

### Logon

When the logon page appears, enter the user name and password, and then click [Login].

When you login for the first time, use the following default user name and password.

Default user name: administrator

Default password: None (enter no data)

---

**IMPORTANT:**

By default, no password is set. Set your password immediately after logging on.

For security, it is recommended to change the default user name as well.

For information on settings and modification, see “BMC Configuration” described later.

---

When the password is authenticated, the following end user license agreement is displayed.

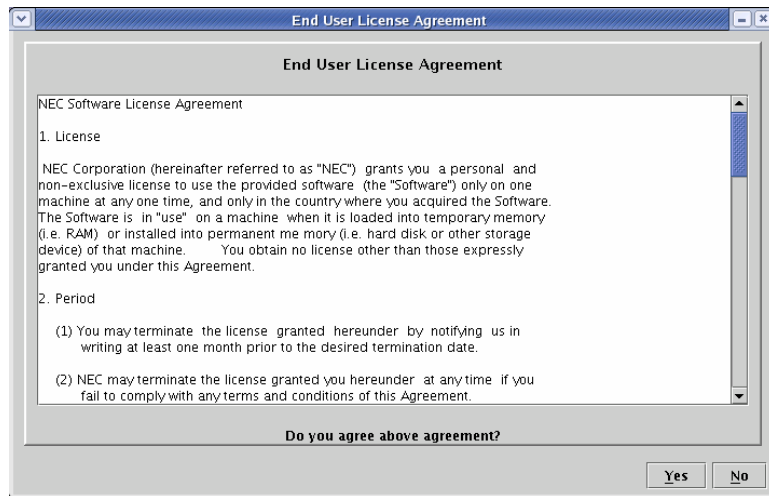

Read the agreement carefully.

If you can agree, click [Yes], and you can start using remote management functions.

If you cannot agree, click [No]. You cannot use remote management functions.

---

**TIPS:**

If you click [Yes], you do not see this message again because the data will be stored on the management PC.

---

## **Logout**

Click the File menu and select Exit to logout. When you log out, the main window closes and you will return to the login page on the browser.

## Main Window

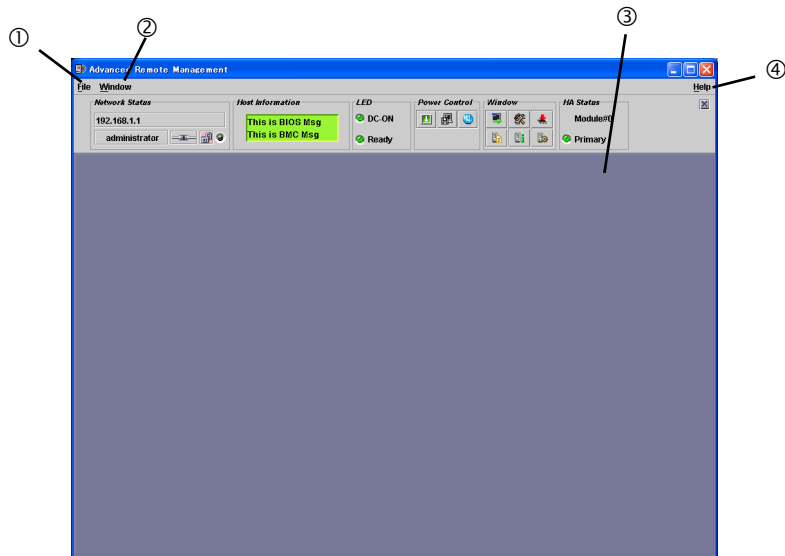

- (1) Click this to show the File menu.  
Click “Exit” to quit this applet.
- (2) Click this to show the Window menu.  
From the Window menu, you can open windows including the KVM console window.
- (3) Main frame  
A window is shown here.
- (4) Click this to show the Help menu.  
Click “Help” to see the version information of this applet.

## Control panel

The control panel allows you to see the server status and to control power.

The control panel also allows you to activate windows.

Control panel functions

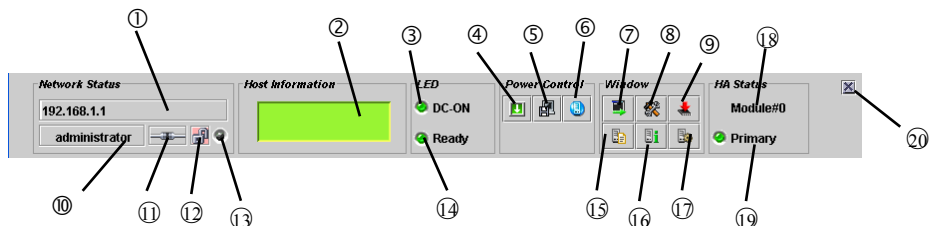

- (1) Displays the BMC host name or IP address
- (2) Displays the LCD of the server.
- (3) The power lamp of the server telling you of the power status
- (4) The same as pressing the POWER switch of the server, but pressing it for 4 or more seconds (the forced power off) is not supported.
- (5) Performs memory dump on the server (the same as pressing the DUMP switch of the server).
- (6) Makes the Unit ID lamp of the server blink
- (7) Starts up the remote KVM console.
- (8) Starts up the BMC configuration.
- (9) Starts up the firmware update.
- (10) A user name is displayed here.
- (11) Displays the connectivity with BMC.
- (12) Displays communication security status
- (13) Displays network access status
- (14) The status lamp of the server telling you of the server status.
- (15) Opens the window showing system event logs (SEL).
- (16) Opens the window showing the sensor device information (SDR).
- (17) Opens the window showing the information on parts to be replaced for maintenance (FRU).
- (18) Displays the slot position information (module #0 or module #1)
- (19) Displays the slot status (primary or secondary).
- (20) Hides the control panel

## Remote KVM Console

Remote KVM console functions of the BMC allow you to transfer a local console to the browser on the management PC over a network.

You can make full access to the server from the management PC using video, keyboard and mouse.

---

### CHECK:

- The remote KVM console supports the following five resolutions:
    - 1024 x 768
    - 800 x 600
    - 640 x 480
    - 720 x 400
    - 720 x 350
  - Set the resolution of the device to one of these values. If any value other than these values, nothing will be shown on the remote KVM console.
  - The mouse cannot be used on the remote KVM console on the operation window of NEC EXPRESSBUILDER.
- 

### TIPS:

KVM is an acronym for keyboard, video and mouse.

The remote KVM control is different from those using a serial console remotely in that it allows you using graphics directly and remotely.

---

### CHECK:

You cannot use the remote KVM remote control for connection via proxy.

When you use the remote KVM console logon with the settings where no proxy is used.

---

### Starting up the remote KVM console window

Click the startup icon [  ] on the remote KVM console on the control panel to display the KVM console window.



#### IMPORTANT:

NEVER open the remote KVM console when you log on to the BMC from a local console.

If you do so, data entry from the keyboard or mouse becomes disabled.

#### CHECK:

You cannot use the KVM console on the secondary side. Use it on the primary side.

### Items on the remote KVM console window

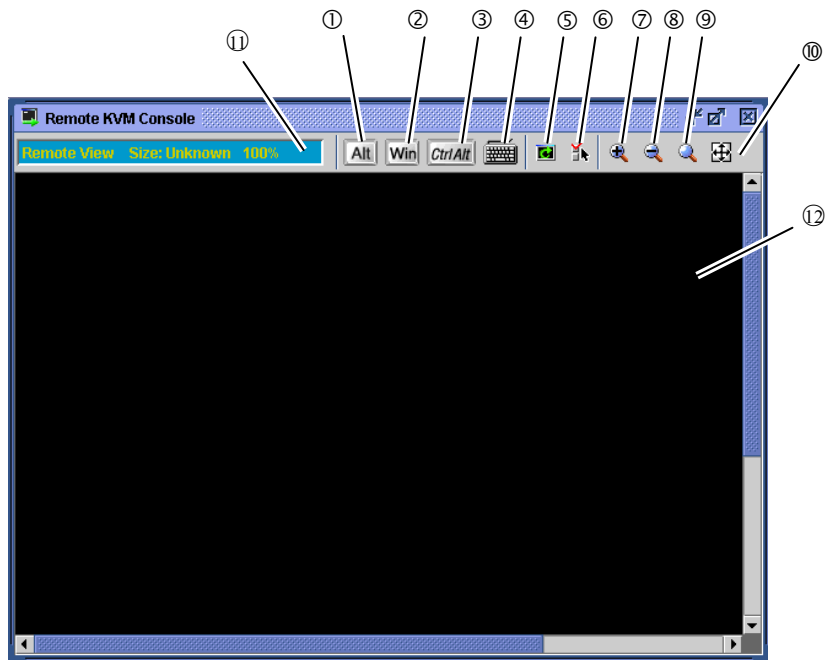

- (1), (2) and (3) are special icons. Use them when you want to operate special keys.
- (4) Virtual keyboard icon: use this icon when you want to enter a special key other than those mentioned above.
- (5) Screen refresh icon: use this icon to refresh the window.



- (6) KVM properties icon.
- (7) Enlarge icon: use this icon to enlarge the view.
- (8) Shrink icon: use this icon to reduce the view.
- (9) Equal size icon: use this icon to display images in the same magnification.
- (10) Window size icon: use this icon to adjust the window size to the screen size.
- (11) KVM indicator showing information including resolution.
- (12) Remote KVM console screen, on which the server screen is shown.

---



**IMPORTANT:**



When you operate **Shift + Caps Lock** or **Num Lock** on the remote KVM console window, such action may not be reflected in the **Shift + Caps Lock** or **Num Lock** status of the management PC LED. Likewise, on the server, the Caps Lock or Num Lock status may become different from LED status after the remote KVM console is used. If this happens, press the key(s) on the device in issue so that LED status and actual operation match.

---

**Operating special keys**

Operation of special keys from the keyboard of the management PC is not reflected in the server. Click the following special key icons for operation on the host server.

 (raised)  (pressed): the status change every time you click the icon.

 (raised)  (pressed): the status change every time you click the icon.

---

**IMPORTANT:**

For example, if you want to enter “**Ctrl + Alt + Del**,” click the [Ctrl] and [Alt] icons and then press the **Del** key on the keyboard. By doing so “**Ctrl + Alt + Del**” is sent to the server. After the operation, click the [Ctrl] and [Alt] icons to cancel the special key operation.

---

 (Windows key icon)

### Virtual keyboard

When you click the virtual keyboard icon [  ], the virtual keyboard appears.





You can select either 104 or 109 keyboard from the tab.  
By clicking buttons corresponding to each key, you can make entry to the host server.

### Zoom-in and zoom-out of the view

Click the [  ] icon to zoom in the view.

Click the [  ] icon to zoom out the view.

Click the [  ] icon to display the screen in the same size as the device.

Click the window resize icon [  ] to adjust the remote KVM console window size to the remote screen size.

### Refreshing the screen

Click the screen refresh icon [  ] to refresh the remote KVM console screen. If the screen is distorted, refresh the screen.

### Modifying properties

When you click the KVM properties icon [  ], the KVM properties window appears, in which you can specify an interval between screen refreshes.

---

#### **IMPORTANT:**

A shorter interval will reduce garbage remaining on the screen. However, note that a shorter interval can slow down the terminal response speed or impact network traffic.

---

## IPMI information

System event logs (SEL), sensor data record (SDR), or field replacement unit (FRU) can be displayed. Such information is referred to as the IPMI information. The information can be used to examine errors and events on the server and identify which part should be replaced.

## System Event Log (SEL)



When you click the icon to start up system event logs [  ] on the control panel, SEL information is collected from the BMC and shown on the system event log (SEL) window as shown below.

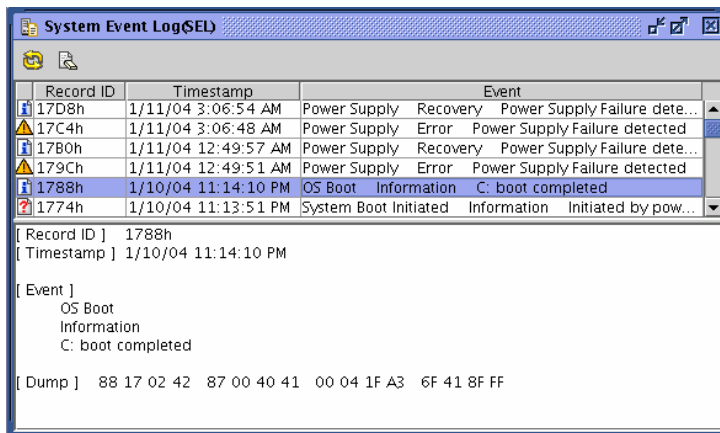

The upper pane shows a list of system event logs while the lower pane shows details of the entry selected in the list.

By clicking the reloading icon [  ], you can reload the SEL information from the BMC and display the latest information.

## Clearing the SEL information

By clicking the SEL clear icon [  ], you can clear the SEL information on the BMC. As a message for confirmation appears, click [Yes] if it is OK to clear the information. If you click [No], the SEL information will not be cleared.

### Sensor Data Record (SDR)



When you click the icon to start up sensor device information (SDR) [  ] on the control panel, the SDR information is collected from the BMC and shown on the sensor device information (SDR) window as shown below.

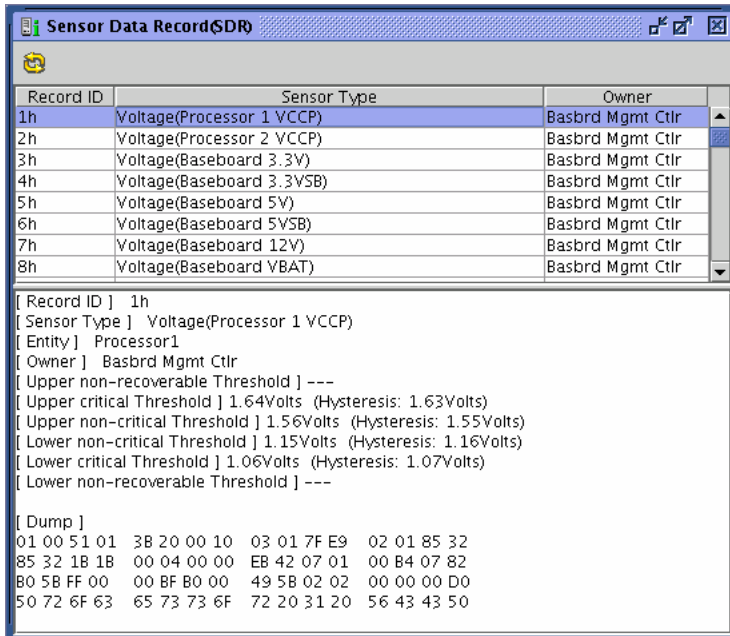

The upper pane shows a list while the lower pane shows details of the entry selected in the list.

**TIPS:**

SDR information is definition data on device sensors.

The BMC monitors sensors according to this information.

## Field Replaceable Unit (FRU)



When you click the icon to start up information on parts to be replaced for maintenance (FRU) [  ] on the control panel, FRU information is collected from the BMC and shown on the window for parts to be replaced for maintenance (FRU) as shown below.

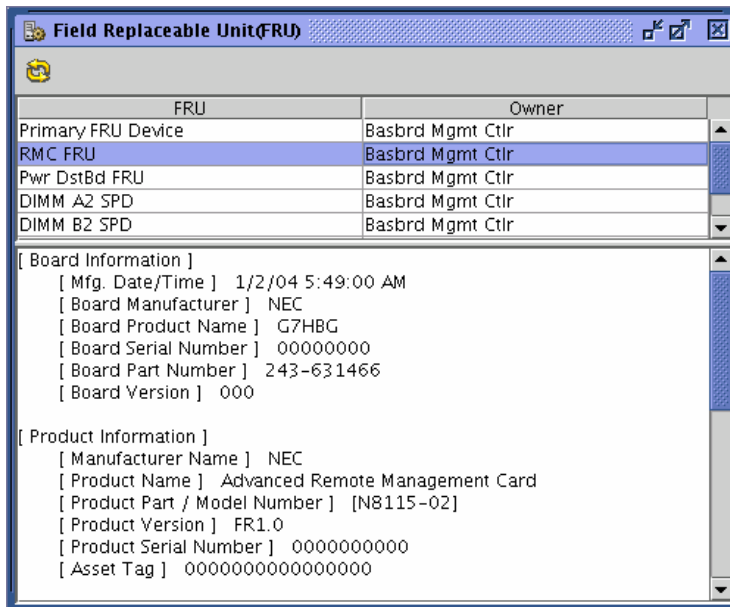

The upper pane shows a list while the lower pane shows details of the entry selected in the list.

## BMC Configuration

You can configure the BMC settings.

### Starting up the BMC Configuration window



When you click the icon to start up the BMC configuration [  ] on Control Panel, the BMC configuration window appears as shown below.

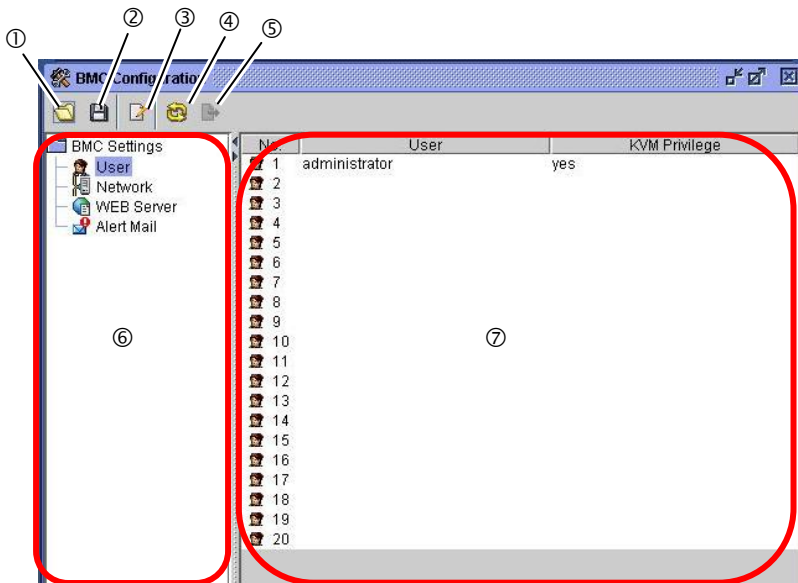

- (1) Reads the BMC configuration file
- (2) Saves the BMC configuration file
- (3) Edits the BMC configuration
- (4) Reloads the BMC configuration
- (5) Sets the data loaded from the file to the BMC in a batch
- (6) Lets you select what to be configured
- (7) Shows the overall information on the current values

### TIPS:

When you load configuration from the file, choose to make settings of the BMC in a batch.

## User Settings

Here you can make user account settings.

When you click [User] on the left pane of the BMC configuration window, total of 20 accounts appear in the right pane.

When you select the account you want to modify or add and click the icon for editing [📄], the following window for editing a user account appears.

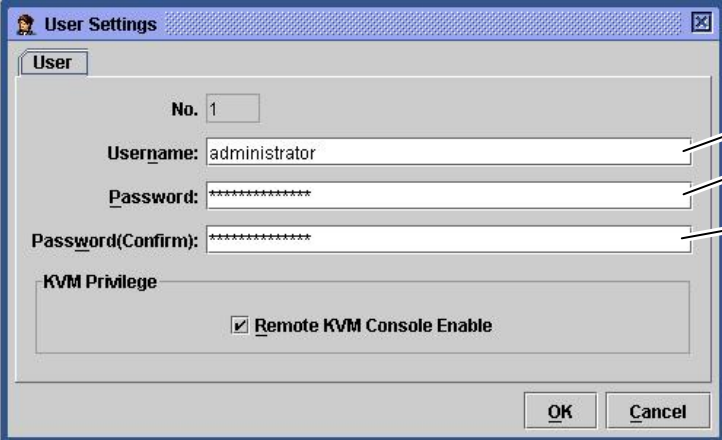

The screenshot shows a dialog box titled "User Settings" with a "User" tab. It contains the following fields and options:

- No.:** A text box containing the number "1".
- Username:** A text box containing "administrator".
- Password:** A text box containing "\*\*\*\*\*".
- Password(Confirm):** A text box containing "\*\*\*\*\*".
- KVM Privilege:** A section containing a checked checkbox labeled "Remote KVM Console Enable".
- Buttons:** "OK" and "Cancel" buttons at the bottom right.

Three numbered callouts (1, 2, 3) point to the Username, Password, and Password(Confirm) fields respectively.

- (1) Enter the user name.
- (2) Enter the password.
- (3) You can specify whether or not to enable the remote KVM console. Select the check box if you want to enable it.

When you click [OK], all the information you have edited will be written into the BMC.  
When you click [Cancel], the window closes without saving what you have edited.

### Network Settings

Here you can make network settings of BMC such as IP address configuration.

#### IMPORTANT:

- The following ports are used for the remote management functions. If your network environment has any firewall, you also need to have configuration for the firewall.

Module name	Port number	Protocol	Direction	Module name	Port number
Remote KVV client	Not determined	UDP	← →	BMC	623
Mail server	25(*1)	TCP	← →	BMC	Not determined
WEB client	Not determined	TCP	← →	BMC	80(*2)
WEB client (SSL)	Not determined	TCP	← →	BMC	443(*3)

- \*1: Can be modified by selecting [BMC Settings] - [Alert Mail] - [E-Mail Alert Settings] - [SMTP] - [SMTP Port Number].
- \*2: Can be modified by selecting [BMC Settings] - [WEB Server] - [WEB Server Settings] - [HTTP Port Number].
- \*3: Can be modified by selecting [BMC Settings] - [WEB Server] - [WEB Server Settings] - [SSL Port Number].

When you click [Network] on the left pane of the BMC configuration window, the right pane shows the overall information of the network settings as shown below.

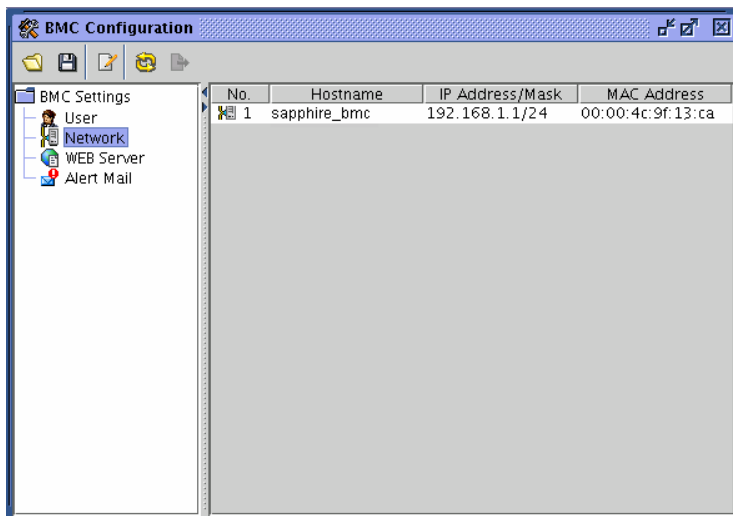

When you click the icon for editing [  ], the following window for editing appears. The window for network settings has three tabs.

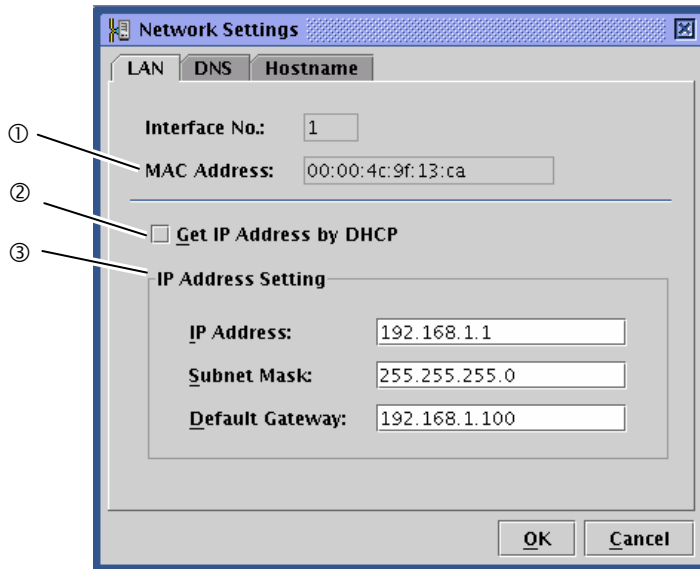

**- LAN**

- (1) The MAC address of the BMC
- (2) Lets you choose whether or not to acquire an IP address automatically by DHCP.
- (3) Lets you make the IP address settings if the address is not acquired automatically by DHCP. If the address is acquired automatically by DHCP, the data acquired is shown here.

**IMPORTANT:**

- Specify different IP addresses to CPU/IO module #0 and CPU/IO module #1.
- If you change the IP address, the current connection will be disconnected when the BMC settings are completed by clicking OK. Close the window once, and then log on again by entering the newly set IP address (or host name) in the browser.
- The logon page remaining on the browser is the page you accessed by using the old address. You cannot use it to log on.
- When you configure “default gateway,” the gateway, the server, the management PC should be in a state where communication over network is available.
- If you make the settings in a state where communication is not available, you need to switch on/off the AC of the server in a state where the gateway, the server and the management PC can be communicated over the network.

**- DNS**

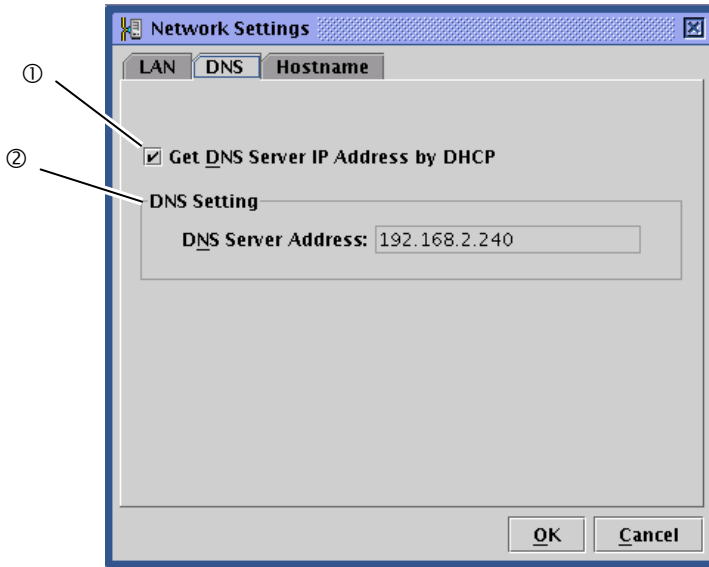

- (1) Lets you select whether or not to automatically acquire the IP address of the DNS server by DHCP.
- (2) If you have selected not to automatically acquire the IP address by DHCP, make settings here. If the address is acquired automatically by DHCP, the acquired address appears here.

## - Host name

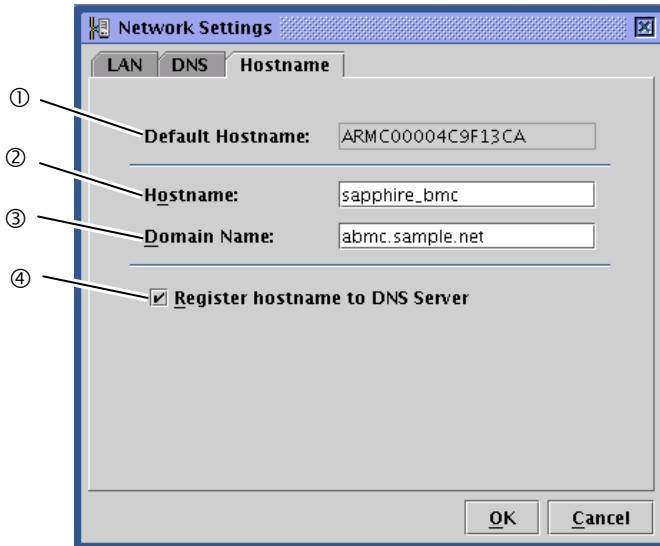

- (1) The default host name to be used when no host name is set when DHCP is used
- (2) Set the BMC host name. If this option is not configured, the default host name mentioned in 1) will be used.
- (3) Set the domain name of the network to which the BMC belongs.
- (4) Choose whether or not to register the host name with the DNS server.

---

### TIPS:

It is recommended to set the BMC host name to be easily guessed from the server's host name on the OS.

For example, you may set the BMC host name as "sapphire\_bmc" if the server's host name on the OS is "sapphire."

---

### IMPORTANT:

Specify different host names to CPU/IO module #0 and CPU/IO module #1.

---

When you click [OK], all of what you have set in the three tabs will be written into the BMC.  
When you click [Cancel], the editing window closes without saving what you have edited.

## WEB server settings

Here you can make web server settings such as HTTP port settings for the BMC.

When you click [Web Server] on the left pane of the BMC configuration window, the right pane shows the overall information of the web server settings.

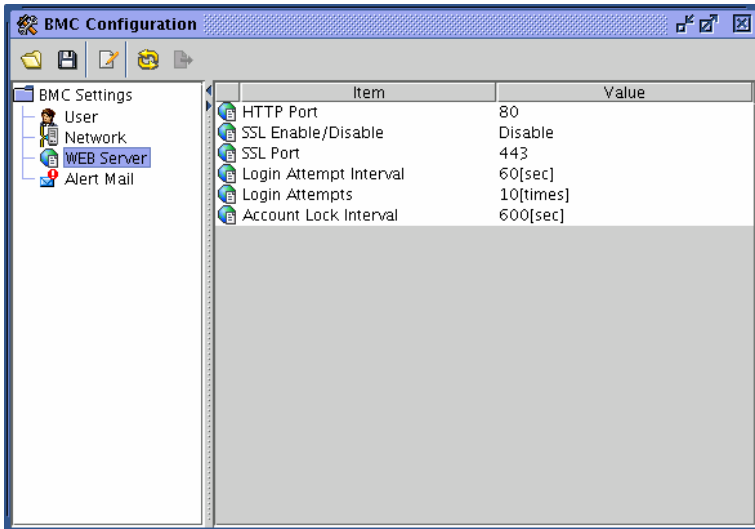

---

### IMPORTANT:

- When you change the HTTP port number, settings of SSL (enable/disable), or SSL port number, the current connection will be temporarily disconnected. Close the window and exit, and then log on again by entering the newly set port number in the browser.
  - The logon page remaining on the browser is the page you accessed by using old web server settings. You cannot use it to log on.
-

When you click the icon for editing [  ], the window for editing appears as shown below.

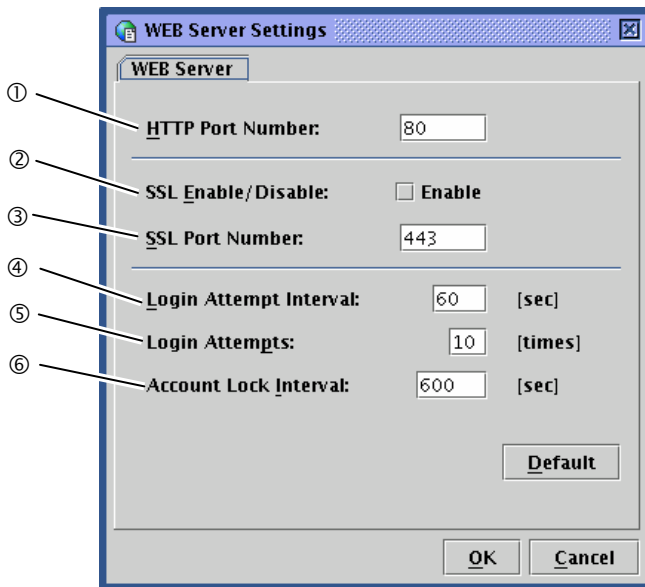

- (1) Specify the HTTP port number.
- (2) Specify whether or not to enable SSL communication. If you select the check box for enabling, connection by HTTPS (SSL enabled) is enabled. Clear the check box if you want to disable SSL.

---

#### **TIPS:**

It is recommended to use connection by the encrypted HTTPS protocol unless you have any specific reason such as SSL cannot be used. By default, this option is disabled.

---

- (3) Specify the SSL port number.
- (4) Specify the logon trial period during which you can try logging on again if you have failed to log on.
- (5) Specify the number of logon retries. If the number of retries exceeds the number specified here during the period specified in (4), logon retries will be rejected for the time period specified in (6).
- (6) Specify the time period during which logon is rejected.

---

#### **TIPS:**

Though the three steps mentioned above are effective in blocking automatic unauthorized logons, they do not completely block such logons.

---

If you click [Default], the default values for HTTP port number, SSL port number, logon trial period, number of logon retries and the account lock period are displayed. The SSL check box configuration remains the same.

When you click [OK], all of what you have set will be written into the BMC.

When you click [Cancel], the editing window closes without saving what you have edited.

### Alert Mail Configuration

Here you can make alert mail settings for BMC.

When you click [Alert Mail] on the left pane of the BMC configuration window, the right pane shows the summary of the alert mail settings.

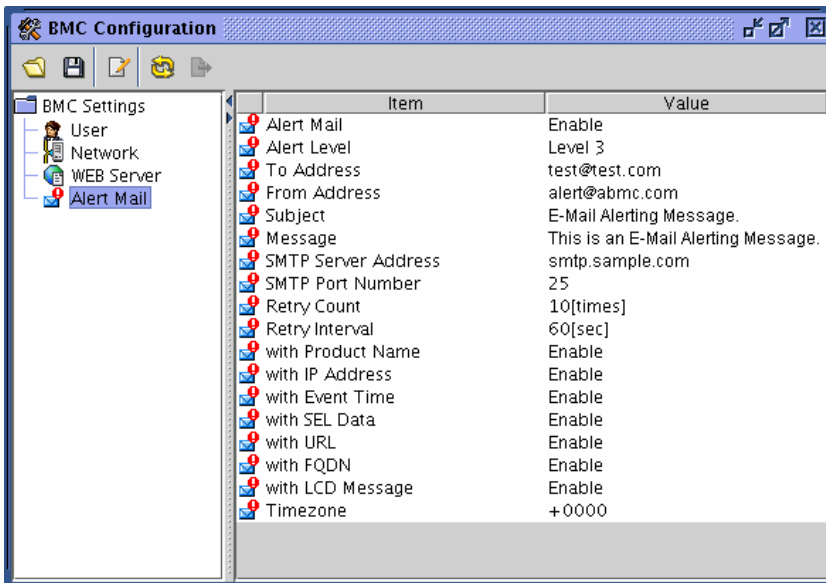

When you click the icon for editing [  ], the window for editing appears as shown in the next page. The window for editing has four tabs.

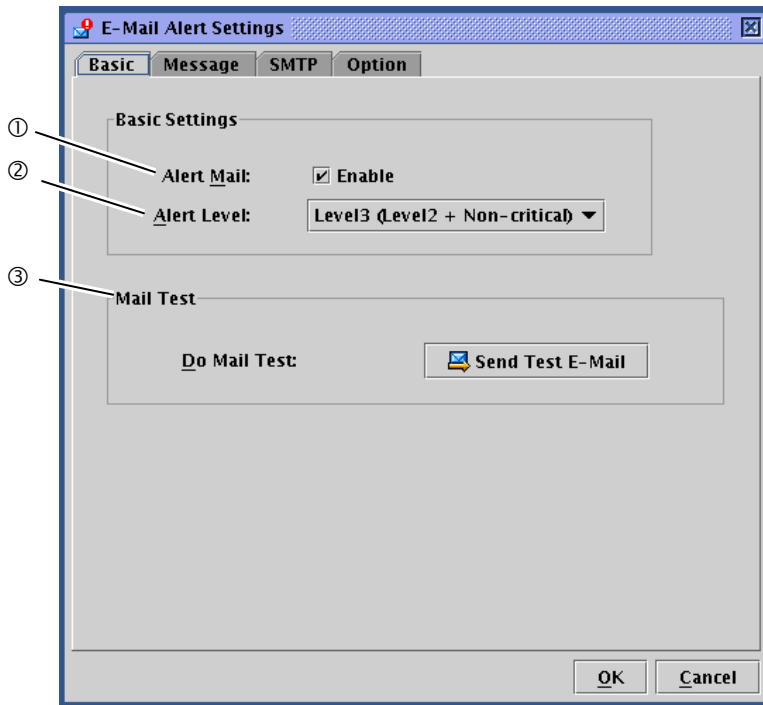
**- Basic**

- (1) Specify whether or not to enable the alert mail functions by the check box. When you select the check box, you can make mail-related settings.
- (2) Select a notice level from six levels. Levels are categorized according to severity of factor events.
- (3) Allows you to send a test mail.

**IMPORTANT:**

Perform the mail test after you have completely configured “E-Mail Alert Settings” described in the following pages.

Making entries in the editing window does not complete settings. You need to click [OK] after entering all the required information to complete the BMC settings.

**TIPS:**

The X-Priority: field in the mail header changes according to the severity of factoring event.

Non-recoverable/Critical	X-Priority: 1
Non-critical	X-Priority: 3
OK/Information/Monitoring	X-Priority: 5

**- Message**

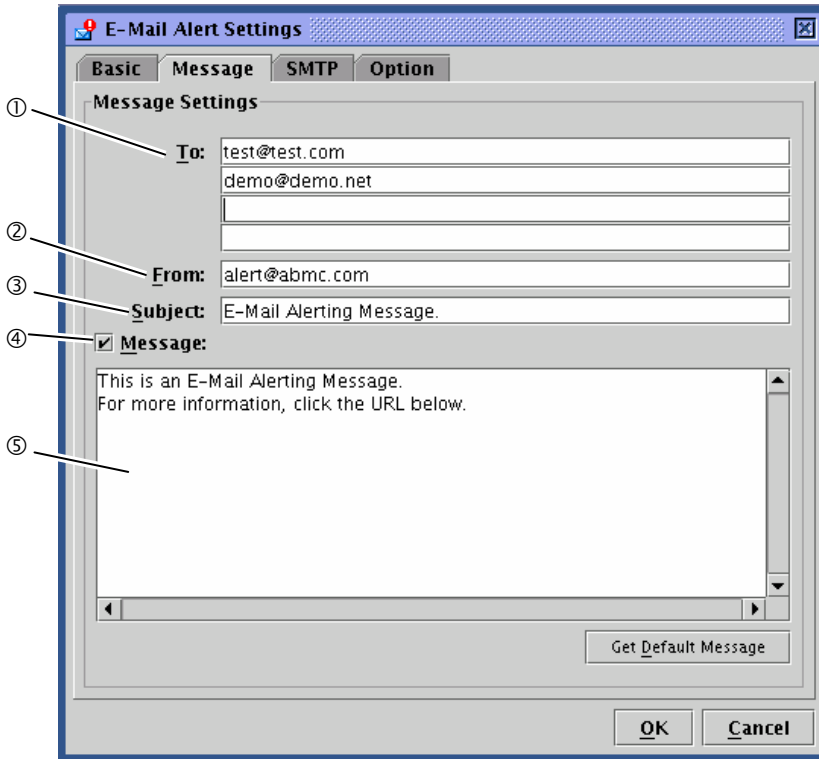

- (1) Specify mail address of receivers to whom alert mail is sent. You can specify up to four addresses.
- (2) Specify the sender's address used in alert mail.
- (3) Enter the subject to be given to alert mail.
- (4) Select whether or not to enable the body messages for all alert mail, which is configured in the next step.
- (5) Enter the body message to be used in all alert mail. If you do not need such a body message, clear the check box of (4). If you click [Get Default Message], the recommended message appears.

---

**TIPS:**

The subject and message you configure here will be used in all alert mails.

---



**- SMTP**

The screenshot shows the 'E-Mail Alert Settings' dialog box with the 'SMTP' tab selected. The 'SMTP Settings' section contains the following fields:

- ① SMTP Server Address: smtp.sample.com
- ② SMTP Port Number: 25
- ③ Retry Count: 3 [times]
- ④ Retry Interval: 60 [sec]

Buttons: [Default], [OK], [Cancel]

- (1) Specify the address of the SMTP server. You can enter the IP address or host name.
- (2) Specify the port number of the SMTP server.
- (3) Specify the number to be made if sending a mail has failed.
- (4) Specify the time period in seconds to wait for next retry.

If you click [Default], the default values for SMTP port number, number of retries, and retry interval appears. It is recommended to use the default values unless you have specific reasons.

---

**IMPORTANT:**

This card does not support SMTP authentication (SMTP-AUTH).

---

**- Option**

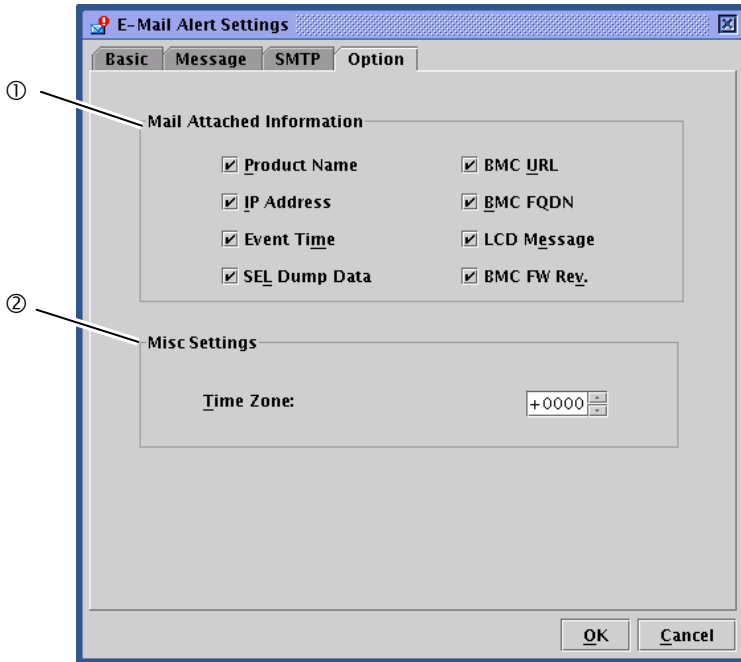

(1) Specify information to be attached to the body of alert mail.

The information you specify here will be contained in the body of alert mail with the message you specified in the message box in the message tab.

Product Information	Product name, code, number of the server
IP Address	IP address of the BMC
Event Time	Time that the event occurred
SEL Dump Data	Data representing system event logs (SEL) in the hexadecimal format
BMC URL	URL of the RMC logon page
BMC FQDN	Full domain name of the BMC
LCD Message	LDC message on the server at the time of event occurrence
BMC FW Rev.	Revision information of the BMC firmware/SDR/PIA

(2) Used in the date filed of the mail header of alert mail.

## Firmware Update

You can update applets, KVM firmware, BMC firmware, sensor device information (SDR), and platform information (PIA).

### Starting up the firmware update window

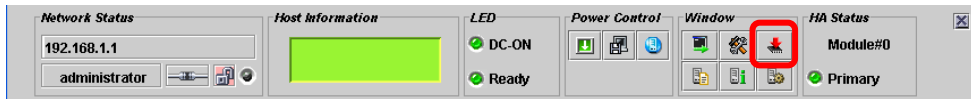

When you click the icon to start up firmware update [  ] on the control panel, each pieces of revision information is loaded from the BMC to display the following firmware update window.

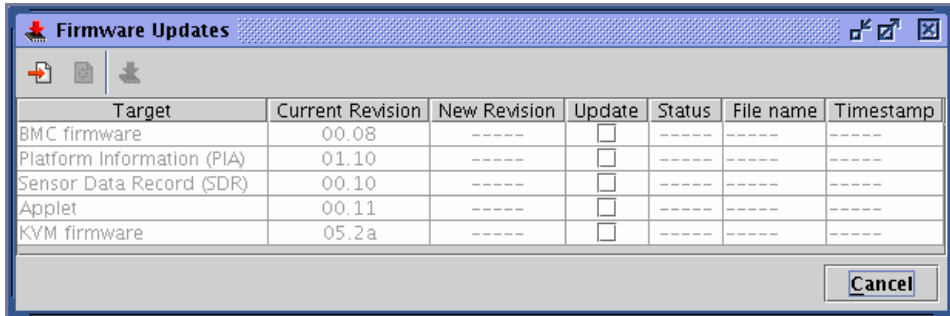

If you click [Cancel], the firmware update window closes without making any changes.

The following pages provide step-by-step instructions for update.

### Loading update data files

When you click the icon for adding update files [  ], the window to select a file appears.

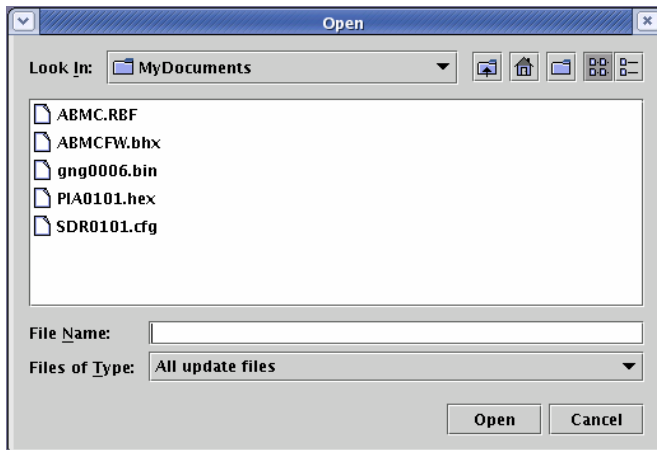

Specify an update data file.

When you click [Open] after specifying the file, loading of the file begins.

Wait for file loading to complete.

---

#### TIPS:

You can update in a batch.

If there are more than one update targets, all the information of the update targets must be loaded. You can select more than one file to be loaded at the same time.

---

### Confirming revision

When loading data files completes, information on current revisions, loaded revisions and file data (file names and time stamps) appears on the window.

Check the information carefully.

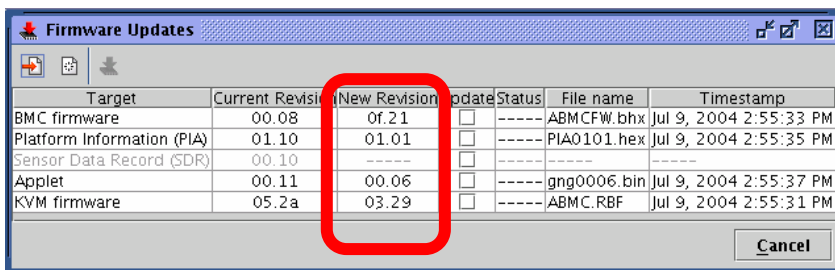

**CHECK:**

Check each revision carefully because downgrading is possible as well.

If you click the icon for clearing update data [  ], all loaded data will be discarded. When you click [Cancel], the update window will be closed without saving any loaded data.

**Selecting what to be upgraded**

Select check boxes of update targets.

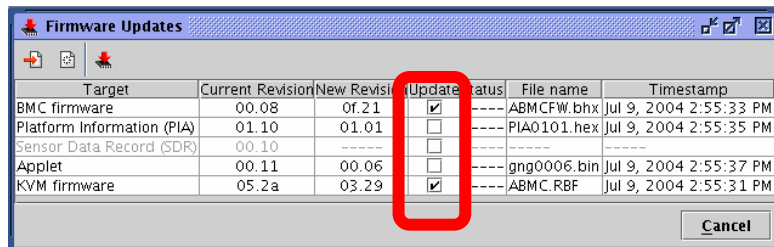
**CHECK:**

Only those selected here will be written in.

Items with no check box selected will not be written in even if files have been loaded.

**IMPORTANT:**

If you update both SDR and PIA, make sure to write in simultaneously. If writing is done twice, the first writing will not take effect.

**Writing update data into the BMC**

When you click the icon for writing update [  ], the writing the update data into the BMC begins.

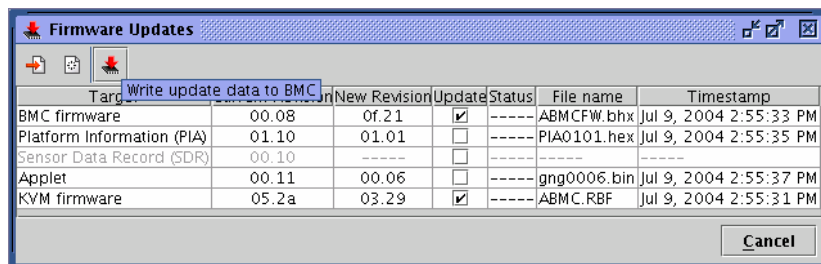

As shown below, the window showing writing process appears for each update target.

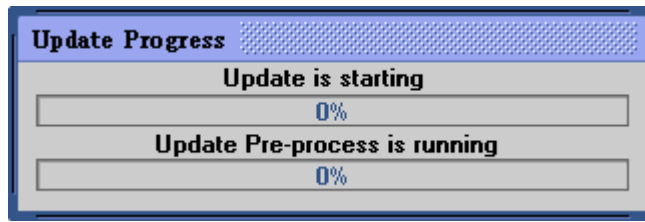

If any error is detected during the writing process, an error message is displayed and the process terminates.

### End of writing

When writing is completed, the "Status" column displays the result for each target.

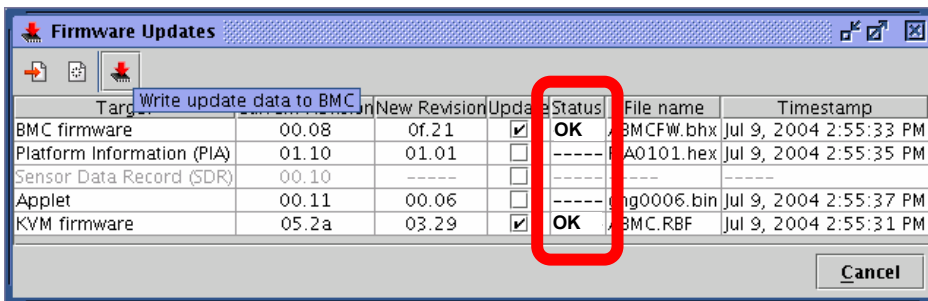

---

### CHECK:

- To apply updates for targets other than applet, reboot the server or power off and then on the server.
  - When you rebooted or power on the server to apply an update for BMC software, SDR, or PIA, the connection with BMC will be disconnected. Because of this, you need to log in again.
  - To apply updates for applets, log out once, close all browsers, and then logon again. You do not need to reboot the server.
-

## Troubleshooting

### Error Messages

When using the remote management, an error dialog box may appear on the management PC if some problem occurs. Messages and actions for the errors are described below.

#### Fatal errors

No.	Error message	Action
1	Fatal error. JavaVM quits.	Try logging in again. If the same message continues to appear, contact your service representative.
2	A fatal software error has occurred.	Try logging in again. If the same message continues to appear, contact your service representative.

#### Logon error

No.	Error message	Action
1	Authentication error	Check the user name and password, and then enter them again.

#### Access privilege error

No.	Error message	Action
1	Unauthorized operation. You have no privilege to perform the operation.	Try performing the operation with administrator's privileges. Consult your administrator.

#### Network errors

No.	Error message	Action
1	The HTTP communication failed.	Check the network environment and try again. Contact your service representative if the error persists. .
2	Could not resolve the IP address.	Check the network environment. You cannot use Remote KVM Console for connections via proxy.
3	Unable to reach the target host.	Check the network environment. You cannot use Remote KVM Console for connections via proxy.
4	Failed to download applet.	Check the network environment and try again. Contact your service representative if the error persists.
5	The RMCP+ session is closed.	Check the network environment. If there is no network problem, contact your service representative.
6	Failed to establish the RMCP+ session.	Check the network environment. If there is no network problem, contact your service

No.	Error message	Action
		representative.
7	The RMCP+ transmission failed.	Check the network environment. If there is no network problem, contact your service representative.
8	The specified RMCP+ protocol cannot be used.	Check the network environment. If there is no network problem, contact your service representative.
9	BMC resources to establish a new RMCP+ session are insufficient.	Try again after a connection from other client is finished.
10	The RMCP+ session time-out occurred.	Check the network environment and server. If you do not find any problem, contact your service representative.
11	The HTTP communication failed.	Check the network environment and try again. Contact your service representative if the error persists. .

**BMC-related error**

No.	Error message	Action
1	The IPMI request was aborted.	The network may be busy. Try again. If the error persists, contact your service representative because a failure may have occurred in BMC.
2	Received bad response from BMC.	Check the server. A failure may have occurred in BMC. If you do not find any problem, contact your service representative.
3	BMC does not support IPMI 2.0 functions.	Contact your service representative.
4	Failed to run the IPMI command.	Check the server. A failure may have occurred in BMC. If you do not find any problem, contact your service representative.
5	Failed to send the IPMI message.	Check the network environment. If the network has no problem, contact your service representative.
6	Illegal IPMI message was requested.	Contact your service representative.
7	Specified target is not present.	Check the server. A failure may have occurred in BMC. If you do not find any problem, contact your service representative.

**Errors on the Remote KVM Console**

No.	Error message	Action
1	Failed to disable Remote KVM Console.	Check the network environment and try again. Contact your service representative if the error persists.
2	Failed to enable Remote KVM Console.	Check the network environment and try again. Contact your service representative if the error persists.
3	KVM packet transmission failed.	Check the network environment and server.



No.	Error message	Action
		If you do not find any problem, contact your service representative.
4	The KVM request was aborted.	This is not a problem. Click [OK] and close the message box.
5	UDP packet transmission failed.	Check the network environment and server. If you do not find any problem, contact your service representative.
6	Remote KVM console can not activate because it is disabled	Refer to page 4-63 and enable remote KVM console.
7	Remote KVM Console is used by other client.	Try again after the client using Remote KVM Console finishes using.
8	Failed to shut down Remote KVM Console.	Use Remote KVM Console after waiting 3 or more minutes.
9	Failed to make settings.	Check the network environment and try again. Contact your service representative if the error persists. .
10	The UDP connection is closed.	Check the network environment and server. If you do not find any problem, contact your service representative.

#### System event log (SEL) display errors

No.	Error message	Action
1	Failed to clear session event logs of BMC.	The network may be busy. Try again. If the error persists, contact your service representative because a failure may have occurred in BMC.
2	Failed to acquire system event logs.	The network may be busy. Try again. If the error persists, contact your service representative because a failure may have occurred in BMC.

#### Sensor data records (SDR) display error

No.	Error message	Action
1	Failed to acquire sensor data records.	The network may be busy. Try again. If the error persists, contact your service representative because a failure may have occurred in BMC.

#### Field replaceable (FRU) information display error

No.	Error message	Action
1	Failed to acquire field replaceable units information.	The network may be busy. Try again. If the error persists, contact your service representative because a failure may have occurred in BMC.

**BMC configuration errors**

No.	Error message	Action
1	Failed to make settings:	Check the network environment and try again. Contact your service representative if the error persists.
2	Failed to acquire BMC Configuration:	Check the network environment and try again. Contact your service representative if the error persists.
3	Used by other software program. Try again after a while.	Try again after a while.
4	Invalid BMC configuration file.	The BMC configuration file may be corrupted. Check the file.
5	The required XML tag is not found.	The BMC configuration file may be corrupted. Check the file.
6	Failed to write the file.	The BMC configuration file is not saved successfully. Change the location to save the file and try again.
7	Invalid user name	You can use only alphanumeric characters, minus sign (-), and underscore (_) for a user name. A user name should be 31 characters or less.
8	The user name is too long	A user name should be 31 characters or less.
9	The password is too long.	Use 16 or less characters.
10	Passwords are not matched.	Enter passwords again.
11	Invalid HTTP port number	You can only use numeric values.
12	Invalid SSL port number	You can only use numeric values.
13	HTTP/SSL should not be the same.	The same port number cannot be specified for HTTP and SSL. Specify different value.
14	Invalid login attempt period	You can only use numeric values.
15	Invalid failed login attempts	You can only use numeric values.
16	Invalid account lock period	You can only use numeric values.
17	Invalid IP address	Use numbers and periods to specify an IP address.
18	Invalid subnet mask	Use numbers and periods to specify a subnet mask.
19	Invalid default gateway	Use numbers and periods to specify a default gateway.
20	Invalid DNS server IP address	Use numbers and periods to specify the IP address of DNS server.

No.	Error message	Action
21	Invalid host name	You can use only alphanumeric characters, minus sign (-), and underscore (_) for a host name. A host name should be 64 characters or less.
22	Invalid domain name	You can use only alphanumeric characters, minus sign (-), and underscore (_) for a domain name. A domain name should be up to 128 characters.
23	The SMTP server address is too long.	Specify the value within 128 characters.
24	Invalid SMTP port number.	You can only use numeric values.
25	Invalid retry count	You can only use numeric values.
26	Invalid retry interval	You can only use numeric values.
27	"To" is too long.	Specify the value within 128 characters.
28	"From" is too long.	Specify the value within 128 characters.
29	"Subject" is too long.	Specify the value within 256 characters.
30	The message is too long.	The message should be up to 1024 characters.
31	Failed to open the file:	The specified file may not exist. Check the file name.
32	Failed to close the file:	The specified file may be corrupted.
33	Can't open the file:	The specified file may not exist. Check the file name.
34	Timeout has occurred.	Try again. If the error persists, contact your service representative because a failure may have occurred in BMC.

### Firmware update errors

No.	Error message	Action
1	There are uncompleted update images on BMC as follows:	Reboot the server to complete the update.
2	Failed to acquire status of the update area.	The network may be busy. Try again. If the error persists, contact your service representative because a failure may have occurred in BMC.
3	Update data is too large:	Some update files may be corrupted. Obtain update files again.
4	Failed to prepare update	The network may be busy. Try again. If the error persists, contact your service representative because a failure may have occurred in BMC.
5	Invalid file size:	The update file may be corrupted. Obtain the update file again.
6	Could not find the revision information:	Some update files may be corrupted. Obtain update files again.

No.	Error message	Action
7	Failed to create rollback image.	Try again. If the error persists, contact your service representative because a failure may have occurred in BMC.
8	Failed to erase.	Try again. If the error persists, contact your service representative because a failure may have occurred in BMC.
9	Unsupported format version:	Some update files may be corrupted. Obtain update files again.
10	Failed to load the update image file.	Some update files may be corrupted. Obtain update files again.
11	Update has failed.	Try again. If the error persists, contact your service representative because a failure may have occurred in BMC.
12	Could not switch to the update mode.	Try again. If the error persists, contact your service representative because a failure may have occurred in BMC.
13	Could not find the update targets:	Some update files may be corrupted. Obtain update files again.
14	Invalid address:	Some update files may be corrupted. Obtain update files again.
15	Writing has failed.	Try again. If the error persists, contact your service representative because a failure may have occurred in BMC.
16	Unsupported token is detected:	Some update files may be corrupted. Obtain update files again.
17	Invalid segment information:	Some update files may be corrupted. Obtain update files again.
18	Invalid data length:	Some update files may be corrupted. Obtain update files again.
19	Failed to open the file:	The specified file may not exist. Check the file name.
20	Failed to close the file:	The specified file may be corrupted.
21	Invalid file checksum:	Some update files may be corrupted. Obtain update files again.
22	Failed to parse files.	Some update files may be corrupted. Obtain update files again.
23	Failed to parse files:	Some update files may be corrupted. Obtain update files again.
24	Failed to load files:	Some update files may be corrupted. Obtain update files again.
25	Could not find files:	Some update files may be corrupted. Obtain update files again.
26	Failed to verify	Try again. If the error persists, contact your service representative because a failure may have occurred in BMC.
27	Update will be stopped because interruption has occurred.	Check clients. A software program other than you are using may have interrupted.
28	Online update is now being used.	Try again as necessary after online update performed by other tool is completed.
29	Failed to acquire the current revision.	The network may be busy. Try again. If the error persists, contact your service representative because a failure may have occurred in BMC.
30	Failed to acquire lines:	Some update files may be corrupted. Obtain update files again.

<b>No.</b>	<b>Error message</b>	<b>Action</b>
31	Invalid line length:	Some update files may be corrupted. Obtain update files again.
32	Unexpected EOF is detected:	Some update files may be corrupted. Obtain update files again.
33	Unexpected token is detected:	Some update files may be corrupted. Obtain update files again.
34	PIA does not suit this server	It is not Platform Information (PIA) of this server. Obtain update files again.

(This page is intentionally left blank.)

# Chapter 5

---

## Installing and Using Utilities

This section describes how to use the NEC EXPRESSBUILDER CD-ROM that comes with your server and to install the utilities stored on the NEC EXPRESSBUILDER.

## NEC EXPRESSBUILDER

The NEC EXPRESSBUILDER, integrated setup software, can automatically detect the hardware connected to an NEC Express5800/ft series machine to advance the processing. The hardware subject to setup with the NEC EXPRESSBUILDER should have the same configuration as that for operation.

---

### Start Menu

The NEC EXPRESSBUILDER provides three procedures to start the server as described below. The menus and items appearing on the screen vary depending on the procedures.

- Booting (starting) the server from NEC EXPRESSBUILDER CD-ROM

For the procedure, insert the NEC EXPRESSBUILDER CD-ROM into the CD-ROM drive of the NEC Express5800/ft series and start the NEC Express5800/ft series from the system in the NEC EXPRESSBUILDER. When the NEC Express5800/ft series is started by using this procedure, the NEC EXPRESSBUILDER top menu shown on the right appears.

Perform the NEC Express5800/ft series setup from this menu.

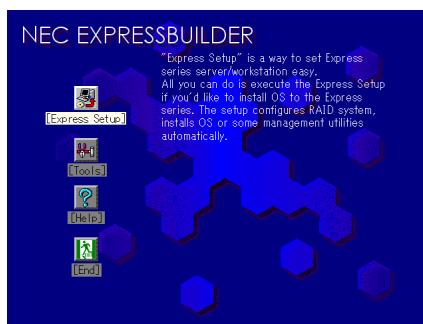

---

### IMPORTANT:

Do not use this CD-ROM on computers other than NEC Express5800/ft series with which it is packaged (including other NEC Express5800 models). Otherwise, a breakdown may result.

---

See "NEC EXPRESSBUILDER Top Menu" for details.



- Inserting NEC EXPRESSBUILDER CD-ROM after Windows startup

The "Master Control Menu" (see the figure below) starts automatically after you place the "NEC EXPRESSBUILDER" in the CD-ROM drive. A dialog box called "Master Control Menu" will appear.

For this dialog, see "Master Control Menu" described later.

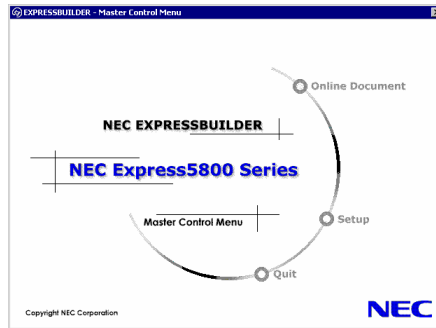

## NEC EXPRESSBUILDER Top Menu

The NEC EXPRESSBUILDER top menu is used for the setup of hardware and the setup and installation of OS.

### Start

Start the NEC EXPRESSBUILDER top menu following the procedure below:

1. Turn on the powers of peripherals and the power of the server in this order.
2. Insert the NEC EXPRESSBUILDER CD-ROM into the CD-ROM drive of the server.
3. After the CD-ROM is inserted, reset the system (by pressing **Ctrl + Alt + Delete**) or turn off the power and then on again to restart the server.

The system is activated from the CD-ROM to start the NEC EXPRESSBUILDER.

After the NEC EXPRESSBUILDER is started, the NEC EXPRESSBUILDER top menu shown below appears.

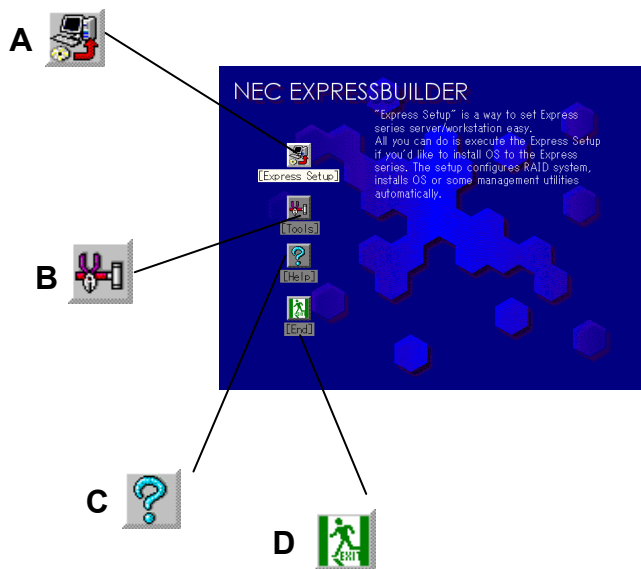

- A Express Setup**  
Performs various automatic setup operations including hardware's internal parameters and status settings and installation of the OS and various utilities automatically. Select this setup method if hard disk drives are used in partitions different from those at purchase or if the OS is reinstalled.
- B Tools**  
Starts each of the utilities stored in the NEC EXPRESSBUILDER individually to allow the operator to provide setup. Enables the setup without influence of installed OS.
- C Help**  
Describes the NEC EXPRESSBUILDER. We recommend you to read through the help before the setup.
- D Exit**  
The NEC EXPRESSBUILDER termination screen appears.

## Setup

This NEC Express5800/ft series setup method is used to perform automatic setup operations from the settings of internal parameters and states of hardware to the installation of Windows Server 2003 Enterprise Edition and various utilities.

Use the setup program if hard disks are used with a partition different from that at purchase, or if OS is reinstalled. This feature carries out the complicated setup.

---

### IMPORTANT:

- To install LINUX on your server, do not use “Express Setup.” Any other methods cannot properly install Windows Server 2003 Enterprise Edition in the server.
  - The Express Setup is assumed to be used when the server has not been set up. Its execution erases the data in the hard disk.
- 

## Tools Menu

The Tools Menu is used to start each of the several utilities stored in the NEC EXPRESSBUILDER CD-ROM individually for manual setup by operator. Use the Tools Menu to provide settings that the setup program cannot do automatically or detailed settings. Also use the Tools Menu when system diagnosis is performed or a support disk is created. The items in the Tools Menu are described below.

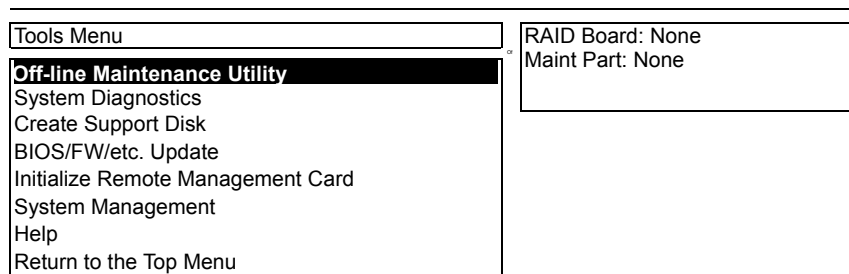

- **Off-line Maintenance Utility**  
Off-line Maintenance Utility is an OS-dependent maintenance program that performs preventive maintenance and error analysis for your server. See Chapter 6 or the online help for details.
- **System Diagnostics**  
Executes several tests on the main system to examine the features of the system and the connections between the system and extension boards. If the system diagnosis is executed, the system check program is started depending on the system status. See the description in Chapter 6 to manipulate the system check program
- **Create Support Disk**  
In the support disk creation procedure, the starting support disk for starting a utility within the NEC EXPRESSBUILDER from a floppy disk and the support disk required in the installation of the operating system can be created. If you write down the titles appearing on the screen on the floppy disk labels, they can be easily managed later.

The customer should prepare the floppy disks for creating the support disks.

- ROM-DOS Startup FD  
The support disk for starting the ROM-DOS system is created.
- Off-line Maintenance Utility FD  
Creates a support disk for activating the Off-line Maintenance Utility.
- System Diagnostics Utility FD  
The support disk for starting the system check program is created.
- System Management Function FD  
The support disk for system management functions is created.

### ■ BIOS/FW/etc. Update

The program which is necessary for the update work is transferred to the floppy disk which the various update modules of BIOS/FW were stored in. After the reboot, an update program is started automatically from the floppy disk, and various BIOS/FW's are updated.

---

#### **IMPORTANT:**

During the execution of the update program, do not turn off the power of the system. If the update is interrupted halfway, the system will not be able to be started.

---

### ■ Initialize Remote Management Card

Allows you to configure ft Remote Management Cards with correct parameters of the system where they are installed. In order to use this menu, modules must be mounted to both systems.

---

#### **IMPORTANT:**

This menu appears when optional ft Remote Management Cards are installed.

---

### ■ System Management functions

Allow you to make settings of BMC (Baseboard Management Controller) to use its report functions and remote control from the management PC.

### ■ Help

Indicates the descriptions on several features of the NEC EXPRESSBUILDER.

### ■ Return to the Top Menu

Indicates the NEC EXPRESSBUILDER top menu.

---

## Master Control Menu

Load the attached “NEC EXPRESSBUILDER” CD-ROM in the CD-ROM drive of the computer that runs Windows (Windows 95 or later, or Windows NT 4.0 or later). The Master Control Menu starts automatically.

---

### TIPS:

The Master Control Menu may not start automatically depending on the system status. In such case, execute the following file on the CD-ROM from the explorer, etc.

`\\MC\\IST.EXE`

---

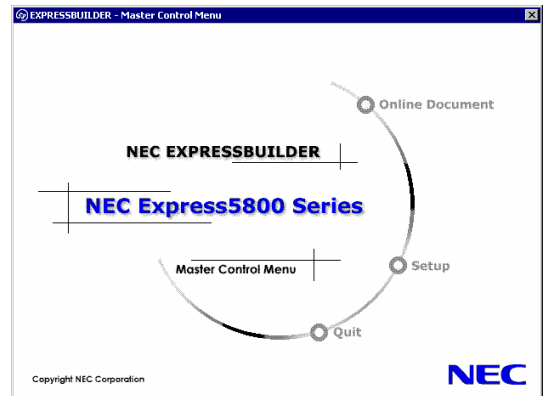

From the Master Control Menu, you can install various kinds of attached software that runs on Windows and view online documents.

---

### TIPS:

Some online documents are provided in the PDF format. To view these files, you need to install Acrobat Reader or Adobe Reader of Adobe Systems Incorporated in advance. If either is not installed, click [Setup] – [Acrobat Reader] first to install Acrobat Reader.

---

For the Master Control Menu operations, click each item displayed on the window, or use the shortcut menu displayed by right-clicking the screen.

---

### IMPORTANT:

Make sure to exit online documents and tools started from the Master Control Menu or menu before removing the CD-ROM from the CD-ROM drive.

---

## NEC ESMPRO Agent and Manager

NEC Express5800/ft series system management applications "NEC ESMPRO Manager" is bundled to accessory CD-ROM "NEC EXPRESSBUILDER" and "NEC ESMPRO Agent" is bundled to Linux for NEC Express5800/ft series Back Up CD-ROM.

This manual describes the functions and features provided by NEC ESMPRO Manager and NEC ESMPRO Agent and the notes on their operations.

These applications are necessary for continuous operation of NEC Express5800/ft series.

---

### Overview

NEC ESMPRO Manager and NEC ESMPRO Agent are the server management software provided for the stable operation of a server system and effective system operations. They can manage the configuration information and operating status of server resources to prevent server faults from occurring. If a server fault occurs, they detect the fault to notify the system Administrator of the occurrence. This enables the system Administrator to take appropriate action against faults.

#### ■ Importance of server management

“Constantly stable operation” and “less management workload” are keywords in server management.

##### – Stable operation of server

Shutdown of a server immediately leads the customer to lose business opportunities and profits. This requires servers to always operate in their perfect state. If a fault occurs in a server, it is necessary to detect the occurrence as soon as possible, make clear the cause, and take appropriate action. The shorter the time taken from the occurrence of a fault to the recovery from the fault is, the smaller the loss of profits (and/or costs) is.

##### – Load reduction of server management

The server management requires many jobs. In particular, if the system becomes large or remote servers are used, required jobs increase further. The reduction of the load of the server management brings the decrease in costs (and thus customer's benefit).

#### ■ What are NEC ESMPRO Manager and NEC ESMPRO Agent?

NEC ESMPRO Manager and NEC ESMPRO Agent are server management software used to manage and monitor NEC Express5800 series systems on the network. The installation of NEC ESMPRO Manager and NEC ESMPRO Agent enables the server configuration, performance, and fault information to be acquired, managed, and monitored realtime and also the occurrence of a fault to be detected immediately by the alert report function.

- Effects of using NEC ESMPRO Manager and Agent

NEC ESMPRO Manager and NEC ESMPRO Agent have sufficient effects on a variety of needs in versatile and complicated system environments.

- Detection of server fault

- NEC ESMPRO Agent collects a variety of fault information on NEC Express5800 series systems to identify the states of the systems. If a server detects a fault, the server provides NEC ESMPRO Manager with the proper alert report.

- Prevention of server fault

- NEC ESMPRO Agent includes the preventive maintenance function predicting the occurrence of a fault in advance as countermeasures for preventing faults from occurring. It can previously detect the increase in the cabinet temperature and the empty capacity in a file system.

- Management of server operation status

- NEC ESMPRO Agent can acquire the detailed hardware configuration and performance information on NEC Express5800 series systems. The acquired information can be viewed at any point through NEC ESMPRO Manager.

- Collective management of distributed servers

- NEC ESMPRO Manager provides the GUI interface that allows servers distributed on the network to be managed efficiently.

## Detection of Server Fault

NEC ESMPRO Manager and NEC ESMPRO Agent detect errors causing faults to occur at an early stage and notify Administrators of fault information real-time.

- Early detection of error

If a fault occurs, NEC ESMPRO Agent detects the fault and reports the occurrence of the fault to NEC ESMPRO Manager (alert report). NEC ESMPRO Manager displays the received alert in the alert viewer and also changes the status colors of the server and server component in which the fault occurs. This allows you to identify the fault at a glance. Further, checking the content of the fault and the countermeasures, you can take appropriate action for the fault as soon as possible.

- Types of reported faults

The table below lists the typical faults reported by NEC ESMPRO Agent.

Component	Reported information
CPU	<ul style="list-style-type: none"> <li>• CPU load is over the threshold</li> <li>• CPU degrading, etc.</li> </ul>
Memory	ECC 1-bit error detection, etc.
Power supply	<ul style="list-style-type: none"> <li>• Voltage lowering</li> <li>• Power failure, etc.</li> </ul>
Temperature	Temperature increase in cabinet, etc.
Fan	Fan failure (decrease in the number of revolutions), etc.
Storage	File system usage rate, etc.
LAN	<ul style="list-style-type: none"> <li>• Line fault threshold over</li> <li>• Send retry or send abort threshold over, etc.</li> </ul>

## Prevention of Server Fault

NEC ESMPRO Agent includes the preventive maintenance function forecasting the occurrence of a fault as countermeasures for preventing faults from occurring.

NEC ESMPRO Manager and NEC ESMPRO Agent can set the threshold for each source in the server. If the value of a source exceeds the threshold, NEC ESMPRO Agent reports the alert to NEC ESMPRO Manager.

The preventive maintenance function can be set for a variety of monitoring items including cabinet temperature, and CPU usage rate.



## Management of Server Operation Status

NEC ESMPRO Agent manages and monitors a variety of components installed in the server. You can view the information managed and monitored by NEC ESMPRO Agent on the data viewer of NEC ESMPRO Manager.

NEC ESMPRO Agent also manages and monitors all the components and conditions required to keep the server reliability at a high level such as hard disks, CPU, memory, fans, power supply, and temperature.

Below is a list of functions of data viewer's items and their availability if NEC ESMPRO Agent is installed.

Function name	Supported	Function description
Hardware	○	Function to display physical information of hardware
Memory bank	○	Function to display physical information of memory
Device Information	○	Function to display device-specific information
CPU	○	Function to display physical information of CPU
System	○	Function to view logical information or monitor load rate of CPU Function to view logical information or monitor status of memory
I/O device	○	Function to view information of I/O devices (floppy disk drive, serial port, parallel port, keyboard, mouse and video)
System environment	△	Function to monitor temperature, fan, voltage, power, door, etc.
Temperature	○	Function to monitor the temperature inside the cabinet
Fan	○	Function to monitor fan
Voltage	○	Function to monitor the voltage inside the cabinet
Power	×	Function to monitor power unit
Door	×	Function to monitor the Chassis Intrusion (open/close of the cover/door on the cabinet)
Software	○	Function to view information of service, driver, OS
Network	○	Function to view information about network (LAN) and monitor packets
Extension device	○	Function to view information of extension bus device
BIOS	○	Function to view BIOS information
Local polling	○	Function to monitor any MIB item value which the agents get

Function name	Supported	Function description
Storage	×	Function to monitor storage devices (e.g., hard disk drive) and controller
File system	○	Function to view file system configuration and monitor usage rate
Disk array	×	Function to monitor disk array system of LSI Logic Corporation
Other	○	Supports OS stall monitoring by Watch Dog Timer

○: Supported    Δ: Partly supported    ×: Not supported

## Monitoring of NEC Express5800/ft series

NEC Express5800/ft series is a fault tolerant system. It can continue the operation even if a major component fails. NEC Express5800/ft series improves the system availability with the hardware, NEC ESMPRO, and system software functions.

If a major component fails, the NEC ESMPRO fault report function can notify the system Administrator of the occurrence of the fault. In addition, the data viewer of NEC ESMPRO Manager can monitor the system status and also identify the failed component.

NEC ESMPRO provides several maintenance functions such as the update of F/W and BIOS in the NEC Express5800/ft series in the online state (in which the system continues the operation but the components used to update F/W or BIOS is suspended) and the suspension of a specific component.

The table below lists the NEC Express5800/ft series management tasks using NEC ESMPRO and system functions.

NEC Express5800/ft series management task	NEC ESMPRO function or tool (on managed NEC Express5800/ft series)	NEC ESMPRO function or tool (on management manager)
Monitoring of major component states	–	NEC ESMPRO Manager data viewer
Diagnosis and start/stop of major components and F/W update	NEC ESMPRO Agent Server Maintenance Utility	NEC ESMPRO Manager data viewer
BMC F/W update	NEC ESMPRO Agent BMC F/W update utility	–
Confirmation of alert or confirmation of fault occurrence event information	syslog	NEC ESMPRO Manager Alert Viewer
Confirmation of H/W error log	NEC ESMPRO Agent	–

The report of a fault occurrence in the NEC Express5800/ft series (alert) is immediately sent to the NEC ESMPRO Manager. When the NEC ESMPRO Manager receives the alert, a popup message appears.

The alert contains the detailed information of the fault and the proper countermeasures. You can take the appropriate action for the alert.

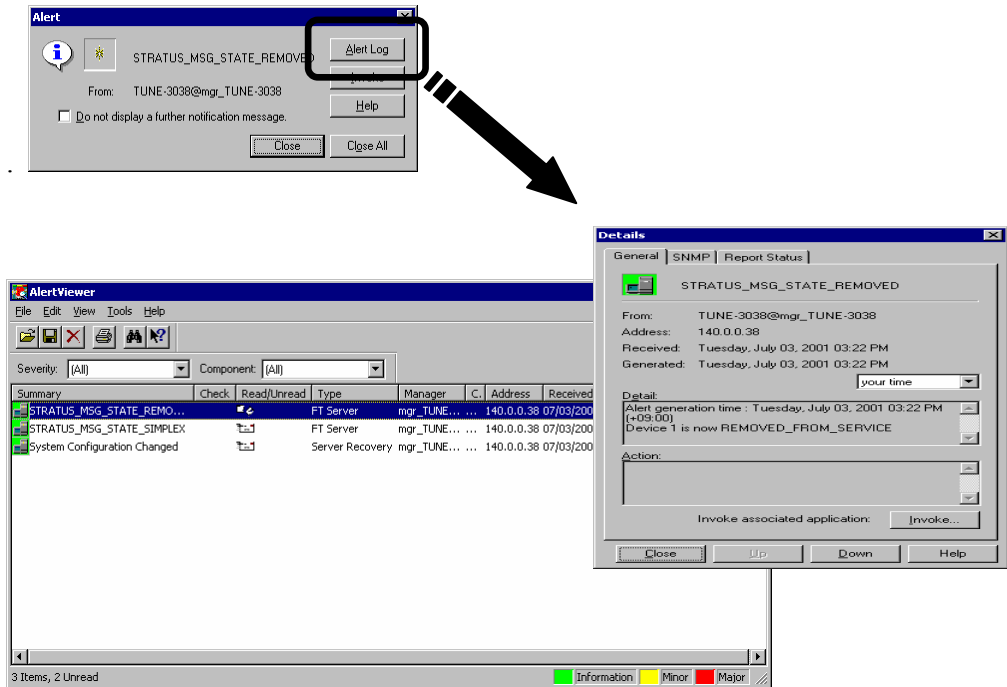

## Collective Management of Distributed Servers

The excellent GUI provided by NEC ESMPRO Manager allows servers on a network to be managed collectively. The management screen is designed in the Explorer format to indicate the components in a server hierarchically for effective server management.

NEC ESMPRO Manager manages servers by using the following three types of GUIs.

- Operation Window

The operation window is used to create the map of servers connected to network to manage them. The map can be multi-layered depending on the installation areas, organizations, and objects.

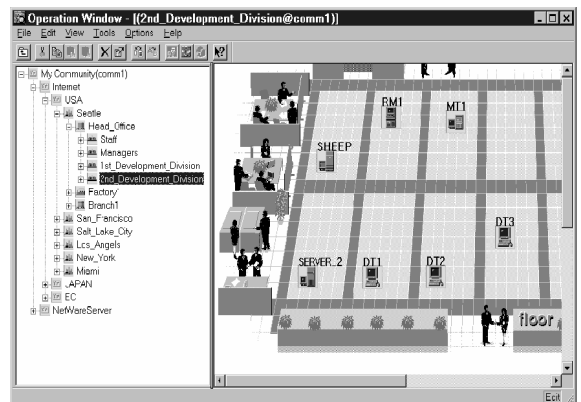

- Data Viewer

The data viewer indicates the server source configuration information in the Explorer format. In addition, it changes the status color of the failed server component. This enables you to identify the failed portion.

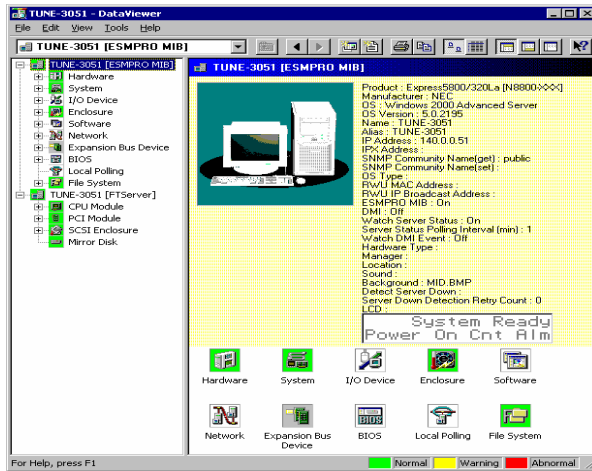

- Alert Viewer

The Alert Viewer manages fault reports sent from servers together. A fault occurred in a server is immediately reported to the Alert Viewer.

The Administrator can recognize all faults on the network instantly.

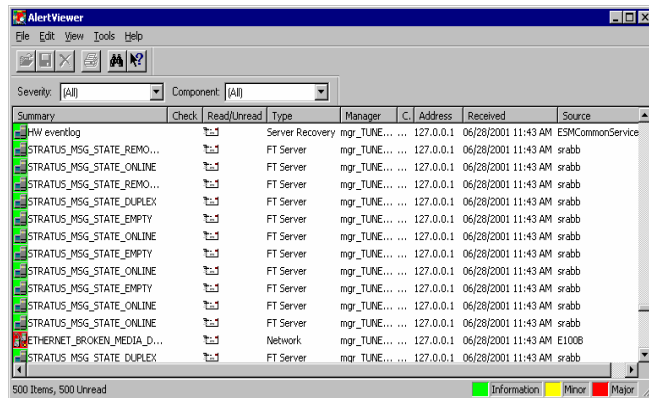

## NEC ESMPRO Agent

NEC ESMPRO Agent is a utility which acts as an agent (proxy) between NEC Express5800/ft series and NEC ESMPRO Manager.

For details on the operating environment, the settings required before the setup, and the installation procedure, see the separate volume, User's Guide (Setup).

## Device ID in Alert Report

Some NEC Express5800/ft series reports use unique device IDs which correspond to the devices listed in the table below as the device identification information.

320Fa-L, 320Fa-LR models

Device name	Device ID
CPU module #0	0/0
DIMM slot A1 on CPU module #0	0/0/0
DIMM slot B1 on CPU module #0	0/0/1
DIMM slot A2 on CPU module #0	0/0/2
DIMM slot B2 on CPU module #0	0/0/3
DIMM slot A3 on CPU module #0	0/0/4
DIMM slot B3 on CPU module #0	0/0/5
CPU #1 on CPU module #0	0/0/20
CPU #2 on CPU module #0	0/0/21
PCI module #0	0/10
PCI slot 1 on PCI module #0	0/10/1
PCI slot 2 on PCI module #0	0/10/2
Slot 1 of riser card on PCI module #0	0/10/3
Slot 2 of riser card on PCI module #0	0/10/4
PCI controller 1 on PCI module #0	0/10/100
PCI controller 2 on PCI module #0	0/10/101
I/O hub on PCI module #0	0/10/102
Display controller on PCI module #0	0/10/103
SCSI adapter 1 on PCI module #0	0/10/104
SCSI bus 1 of SCSI adapter 1 on PCI module #0	0/10/104/0
SCSI bus 2 of SCSI adapter 1 on PCI module #0	0/10/104/1
Ethernet adapter on PCI module #0	0/10/105
CPU module #1	1/1
DIMM slot A1 on CPU module #1	1/1/0
DIMM slot B1 on CPU module #1	1/1/1
DIMM slot A2 on CPU module #1	1/1/2
DIMM slot B2 on CPU module #1	1/1/3
DIMM slot A3 on CPU module #1	1/1/4
DIMM slot B3 on CPU module #1	1/1/5
CPU #1 on CPU module #1	1/1/20
CPU #2 on CPU module #1	1/1/21
PCI module #1	1/11
PCI slot 1 on PCI module #1	1/11/1
PCI slot 2 on PCI module #1	1/11/2
Slot 1 of riser card on PCI module #1	1/11/3
Slot 2 of riser card on PCI module #1	1/11/4
PCI controller 1 on PCI module #1	1/11/100
PCI controller 2 on PCI module #1	1/11/101

Device name	Device ID
I/O hub on PCI module #1	1/11/102
Display controller on PCI module #1	1/11/103
SCSI adapter 1 on PCI module #1	1/11/104
SCSI bus 1 of SCSI adapter 1 on PCI module #1	1/11/104/0
SCSI bus 2 of SCSI adapter 1 on PCI module #1	1/11/104/1
Ethernet adapter on PCI module #1	1/11/105
SCSI enclosure	41
SCSI slot 0 on SCSI enclosure	41/0
SCSI slot 1 on SCSI enclosure	41/1
SCSI slot 2 on SCSI enclosure	41/2
SCSI slot 3 on SCSI enclosure	41/3
SCSI slot 4 on SCSI enclosure	41/4
SCSI slot 5 on SCSI enclosure	41/5

The figure below shows the actual locations of the device names displayed on the NEC ESMPRO screen. In the case of the tower model, modules are mounted vertically instead of horizontally.

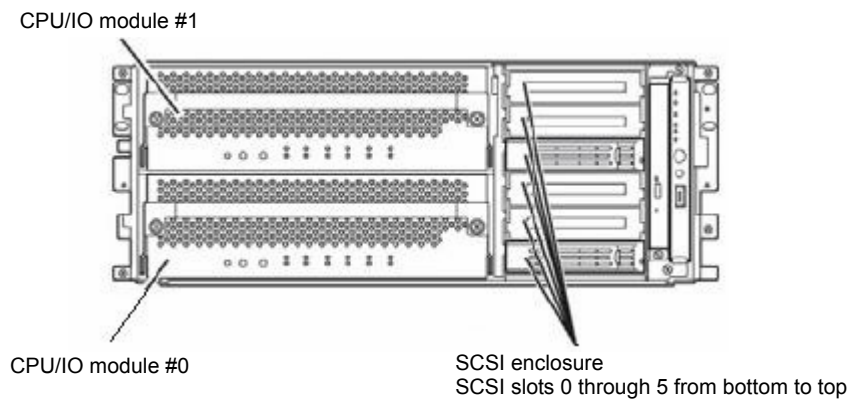

Front view of the rack-mount model

## Supplement

Note the following when using NEC ESMPRO Agent.

### Dual registration of syslogs

At some types of errors, two syslogs may be registered for a single occurrence. (However, in the case of NEC ESMPRO Manager, one log is reported for one occurrence.) Such errors are as follows:

- Temperature error
- Voltage error
- Thermal trip

### Maintenance-related Functions

When you want to use maintenance-related functions, contact your maintenance personnel.

### CPU Information

If you select [CPU Module]–[CPU] in the FT tree of the data viewer, unknown or incorrect information appears in some information items.

The CPU information can be viewed by selecting [System]–[CPU] in the [ESMPRO] tree.

### Module Diagnostics

When you diagnose a PCI module (IO module), the CPU module of the same side will also be diagnosed. Therefore, the CPU module also needs to be stopped.

### Status during Module Diagnostics

While diagnosing a stopped module, the module is no longer in the duplex mode and the CPU and the memory cannot be used. However, the status of [CPU] and [DIMM] displayed under [CPU module] in the FT tree on a Data Viewer becomes “Online” and the status color becomes green.

### Change of Installation States of CPU and PCI (IO) Modules

If you dynamically change the configuration of the CPU or PCI module (IO module) in the relevant system during review of the server information by using the data viewer, the message prompting you to reconstruct the tree of the data viewer will appear. If you click the [Yes] button, the tree is reconstructed in the data viewer to reflect the change of the system configuration on the data viewer. Clicking the [No] button does not cause the tree to be reconstructed in the data viewer. If so, the information in the data viewer may be different from the current system information because the change of the system configuration is not reflected on the data viewer.



### **Status of Logical PCI Slots**

Because the I/O hub and display controller on a PCI module (IO module) are logical PCI slot information, PCI module (IO module) are not influenced by them. Therefore, the “Status” of [PCI slot (ID:0/10/102)] and [PCI slot (ID:0/10/103)] under [PCI module (ID:0/10)] and the “Status” of [PCI slot (ID:1/11/102)] and [PCI slot (ID:1/11/103)] under [PCI module (ID:1/11)] in the FT tree on a Data Viewer becomes “Online” and the status color becomes green.

### **Impact of Module Status Changes**

PCI modules (IO modules), SCSI adapters, SCSI buses, and modules under the SCSI enclosure have impact on each other. For example, when the “Status” item of a module changes to “fault,” it may be caused by another module’s error. Therefore, you need to check the status of the other modules based on alert information.

### **Status Color after Mounting a Hard Disk**

When creating a new mirror, the status of the hard disk and its upper component, SCSI enclosure, will continue to change after you mount a hard disk until the mirror is completed. The OS may take several minutes to recognize changes of disk status or the disk may need to be rescanned. During this process, the status color may turn to abnormal, but when the mirror is created successfully, it will return normal.

### **LAN Monitoring Report**

The LAN monitoring function defines the line status depending on the number of transmission packets and the number of packet errors within a certain period. Thus, the LAN monitoring function may report a line fault or high line load only in a temporary high line impedance state. If a normal state recovery is reported immediately, temporal high line impedance may have occurred thus there is not any problem.

### **LAN Monitoring Threshold**

Because hardware faults on the network are found in the driver level, NEC ESMPRO Agent does not monitor line faults.

### **Community Authority**

Depending on your OS type or its version, settings for community, SNMP service’s security function, are not made, or default settings of authority are different

To enable the remote shutdown and threshold change functions via NEC ESMPRO Manager, make settings of community and set its authority to "READ CREATE" or "READ WRITE."

### **Monitoring with NEC ESMPRO Manager Ver.4.22 or Earlier**

NEC ESMPRO Manager Ver.4.23 or later is required for monitoring the server.

If you are using an older version, you must install NEC ESMPRO Manager using the CD-ROM shipped with the server.

### **ESRAS Utility**

ESRAS Utility runs on NEC Express5800 series with NEC ESMPRO Agent installed, and is used to display, print, and initialize logs and export them to a file.

If you attempt to collect ipmi.dat immediately after starting the OS or disconnecting the system, a message “IPMI driver operation error” is displayed. Wait awhile and try collecting ipmi.dat again.

### **Coexistence with the Oracle products**

The installation of the Oracle products may change Startup Type of SNMP Service into “Manual.” If so, change the setting back to “Automatic” and set up correctly according to the description of the Oracle product.

### **Connection with Hard Disk Drive**

The preventive hard disk drive maintenance function may not work properly when a hard disk drive which was used in a system where NEC ESMPRO Agent is installed is connected to other systems. Make sure not to connect such hard disk drives.

### **Change Settings of File System Monitoring Function**

New settings in thresholds of monitoring interval and free space monitoring are not reflected immediately after they are changed. They are reflected at the next monitoring interval of monitoring service.

### **CPU Load Ratio of SNMP Service (snmpd)**

While monitoring the server from NEC ESMPRO Manager, the CPU load ratio of SNMP Service on the NEC ESMPRO Agent side may increase at every monitoring interval (default: 1 minute).

NEC ESMPRO Manager and NEC ESMPRO Agent exchange information through SNMP Service. If the server status monitoring by NEC ESMPRO Manager is on (default: ON), NEC ESMPRO Manager regularly issues a request to NEC ESMPRO Agent to get the current status of the server. In response, NEC ESMPRO Agent checks the status of the server. As a result, the CPU load ratio of SNMP Service increases temporarily.

If you have trouble of terminating a movie player application, turn off the server status monitoring by NEC ESMPRO Manager or extend the monitoring interval.

## Current Status of Temperature, Voltage and Fan Sensors

Some modes are equipped with temperature/voltage/fan sensors that do not have information on status, current values, rpm, threshold etc. Therefore, if you view such a sensor on NEC ESMPRO Manager, it may be displayed as follows:

- The status becomes “Unknown” (grayed out) on the data viewer.
- The current value or rpm becomes “Unknown” on data viewer.

Even if the sensor is displayed like stated above, it is monitoring the server.

## Actions to Take When Temperature/Voltage Error Occurs on CPU/PCI Modules

At the time when a temperature or voltage error occurs on CPU/PCI module (CPU/IO module), necessary actions will differ depending on its status as shown below. You can check the status of each module from the data viewer of NEC ESMPRO Manager or Server Maintenance Utility.

Status	Actions
Duplex	Stop the failed CPU/PCI module (CPU/IO module).
Simplex	Shut down the system.

### TIPS:

- If the status is “Empty Absent,” the module is not mounted. Sensor monitoring is not conducted.
- If disks are mounted on PCI modules (IO modules), the status of both modules is “Simplex” while the disks are mirrored. Temperature or voltage error occurring during disk mirroring will result in the system to shut down.

## CPU Information

In [CPU Information] of Data Viewer’s system tree, the external clock is listed as “Unknown.”

## When [ft] Tree Appears on Date Viewer in an Incorrect Manner

If you open a Data Viewer immediately after the system starts up, the tree or the state of a Data Viewer may not be displayed correctly due to high load of the system. In about 20 minutes after the system startup, when a pop-up message (below) which prompts you to reconstruct a Data Viewer appears, click [OK]. The Data Viewer will be reconstructed and the tree and the status will be displayed correctly. If the [ft] tree is not displayed, delete the icon and register the server again by using the NEC ESMPRO Manager.

## Floppy Disk Drive Information

If you add or delete floppy disk drive connected with USB while the system is running, the drive information under the [I/O Device] in the data viewer will be updated at the next system startup.

### **When the Displayed BIOS Information is Incorrect**

Additional information of BIOS which is displayed by clicking [ft] - [CPU Module] - a CPU module - [General] - [BIOS Information] on a Data Viewer or by clicking a CPU module and clicking [BIOS Information] on Server Maintenance Utility may not be displayed correctly. In such a case, display the BIOS information on a Data Viewer by clicking [ESMMIB] - [BIOS].

### **Ethernet Adapters You Do Not Use**

If an Ethernet adapter is not used (not connected to cable), set it to “Disable” in [Network Connections] from Control Panel. If an Ethernet adapter you are about to disable has dual LAN settings (AFT function), remove the dual LAN settings before disable it.

### **Monitoring in Sleep State**

NEC ESMPRO Manager cannot monitor the NEC ESMPRO Agent machine in the sleep state (system standby or system halt state).

While NEC ESMPRO Manager monitors server shutdown, the relevant NEC ESMPRO Agent machine may be entered into the sleep state. If so, the report "server access disabled" is issued and the status color of the server icon becomes gray. This cannot indicate whether the NEC ESMPRO Agent machine is shut down or entered into the sleep state. Keep these in mind when operating the system where systems to be monitored may enter the sleep state.

### **Hang of SNMP Service**

SNMP Service has a module called “SNMP Extended Agent.” This module may be registered when you install some software that uses SNMP Service.

If you start SNMP Service, SNMP Extended Agent is also loaded at the initialization. However, if the initialization is not completed within a specified period, SNMP Service will hang.

It may take time to complete the initialization due to temporary high load on the system. In this case, wait for the system load become low enough before restarting SNMP Service.

### **SCSI Status on a Data Viewer**

“Unknown” is always displayed for the following items:

- “Serial Number,” “Firmware Revision” and “ROMBIOS Revision” in “General” of “SCSI Adapter”
- “Reassign Block Count” and “Reassign Block threshold” in “General” of “SCSI Slot”

### **SCSI Status while IO Module is Starting or being Stopped**

While an IO module is starting or being stopped, the status of SCSI adapters, SCSI bus, SCSI enclosure, SCSI slots, and mirror disks temporarily indicates an undefined status. Once the module is started or stopped, the status will return to normal.

### **Status of SCSI Slots and Mirrored Disks at High Load**

When the system load is high, the status of SCSI slots and mirror disks may not be obtained, and incorrect status may be displayed temporarily.

### **SCSI Slot Indication when a Disk Fails**

When a disk which has failed before is mounted, the SCSI slot status becomes “Broken.” The status changes from “Broken” when a mirror volume is created on the disk or any mirror volume is resynchronized.

### **Monitoring NEC Storage**

NEC ESMPRO Agent (Linux) does not monitor the failure status in NEC Storage. If you go to Data Viewer and select [ESMPRO] – [File System], the File System status is indicated as “Unknown.” However, this will not affect your system operation.

### **Bonding configuration displayed by NEC ESMPRO Manager**

NEC ESMPRO Manager displays ten bonds, from bond0 to bond9, including unconfigured bonds.

### **Operation error of NEC ESMPRO Agent**

NEC ESMPRO Agent uses “portmap.” If “portmap” is stopped (restarted), NEC ESMPRO Agent cannot function normally. In that case, run the command below to restart NEC ESMPRO Agent.

```
# /opt/nec/esmpro_sa/bin/ESMRestart
```

### NEC ESMPRO Manager

To monitor and manage a computer, on which NEC ESMPRO Agent is installed, with a management PC online, use NEC ESMPRO Manager that is bundled with the product.

For detailed procedures of installation and setting, see online documents or NEC ESMPRO Online Help.

---

#### **TIPS:**

Online documents provide cautions and information for using NEC ESMPRO Manager. See *NEC ESMPRO Manager User's Guide* in the NEC EXPRESSBUILDER CD-ROM.

---

### **Monitoring by Use of Data Viewer**

To monitor the state of the NEC Express5800/ft series on a management computer with installation of NEC ESMPRO Manager, the data viewer is used. If you click each of the modules and items to be checked sequentially on the tree view in the Windows Explorer format, the data viewer indicates their states on the right side of the screen.

You can manage the status on a Web browser using Web component functions of NEC ESMPRO Manager. For details, see Help on Web Component.

This section describes the tree structure and displayed screens in the data viewer.

To make the data viewer indicate the state of each module and those of the components on it, select the server to be monitored from NEC ESMPRO Manager to start the data viewer (in the following description, the start procedure of the data viewer is omitted).

The server is physically configured with two modules, but each module has a CPU module and IO module. Therefore, NEC ESMPRO Manager Data Viewer displays module #0 and module #1 in a tree and under each of them, a CPU module and PCI module are displayed (on a Data Viewer of NEC ESMPRO Manager and Server Maintenance Utility of NEC ESMPRO Agent, the IO module is indicated as "PCI module").

## Monitoring CPU Module

To monitor the CPU modules and the components on the CPU module, see the [CPU Module] tree. To see the information on the [CPU Module] tree, select the target CPU module from [CPU Module] in the [ft] tree.

You can see the following information on the modules and the components on the CPU modules in the [CPU Module] tree.

- General

Allows the configuration and other information on the CPU modules to be viewed.

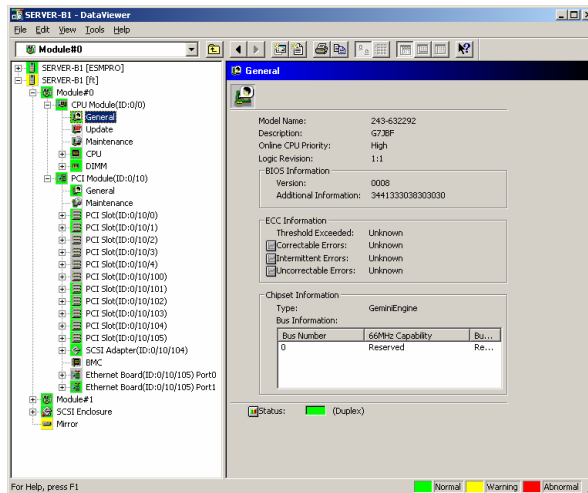

- Maintenance

Allows the start/stop, MTBF information clear and dump acquisition of the CPU modules to be provided. See "Maintenance of NEC Express5800/ft series" described later for the start/stop and MTBF information clear of the CPU modules.

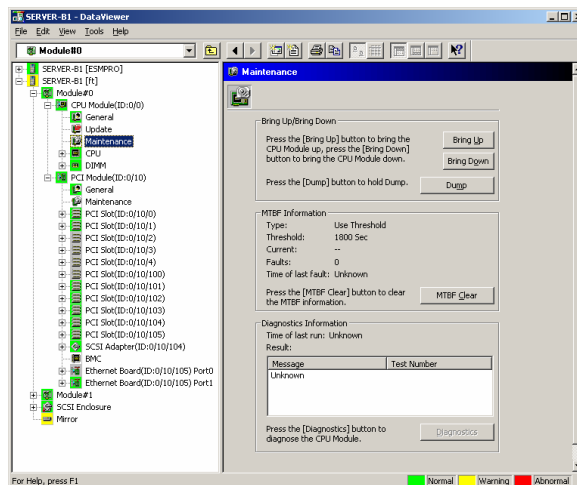

■ Update

Allows the device identification information of the CPU modules to be viewed and BIOS of the CPU modules to be updated. See "Maintenance of NEC Express5800/ft series" described later for the update of BIOS of the CPU modules. The detailed device identification information can be checked by selecting [ESMPRO] tree→[Hardware] tree→[Field Replaceable Unit] tree.

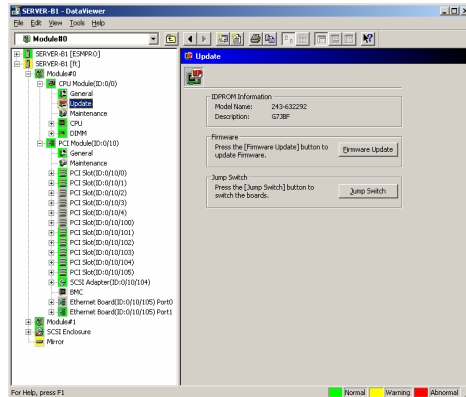

■ CPU

Allows the information of the CPU on the CPU modules to be viewed.

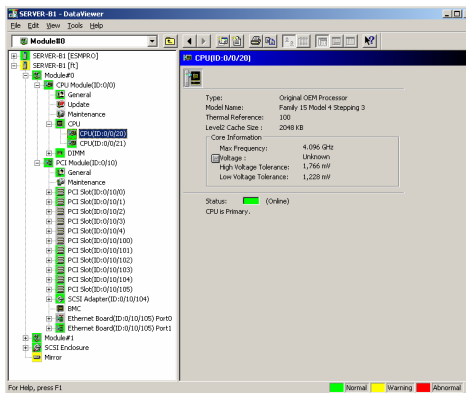

■ DIMM

Allows the information of DIMM on the CPU modules to be viewed.

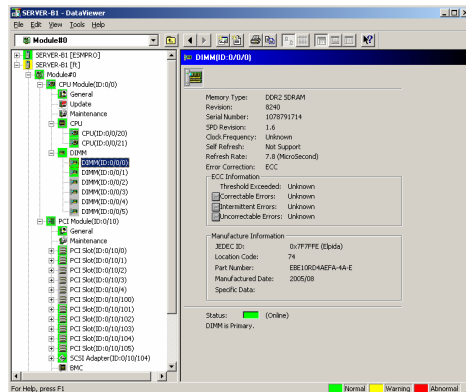



## Monitoring IO Module

To monitor the IO modules and the components on the IO modules, refer to the [PCI Module] tree. To see the information on the [PCI Module] tree, select the target IO module from [PCI Module] in the [ft] tree.

You can see the following information on the IO modules and the components on the IO modules of the [PCI Module] tree.

(This section describes the general information screens of the IO modules. The components on the IO modules are described later.)

- General

Allows the configuration and other information of the IO modules to be viewed.

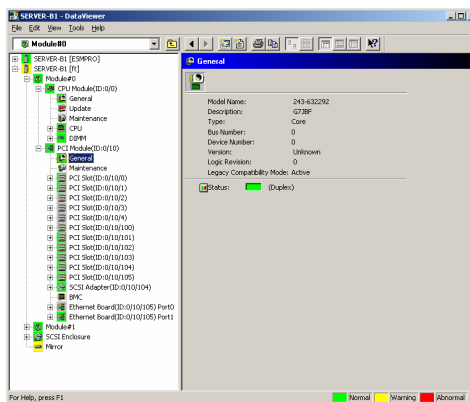

- Maintenance

Allows the start/stop, MTBF information clear, and diagnostics of the IO modules to be provided. See "Maintenance of NEC Express5800/ft series" described later for the start/stop and MTBF information clear of the IO modules.

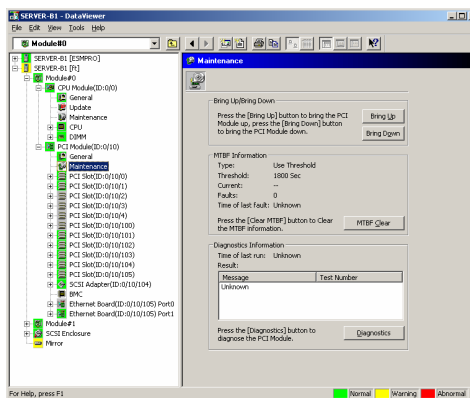

### Monitoring PCI Slots and Devices on IO Module

To monitor the PCI slots and devices on the IO modules, see the [PCI slot] tree. To see the information on the [PCI slot] tree, select [PCI Module]→[PCI module (containing PCI slot to be seen)]→[PCI slot] of the [ft] tree.

You can see the following information on the PCI slot and the devices on the PCI slot in the [PCI slot] tree.

- General

Allows the PCI slot configuration information to be viewed.

**CHECK:**

The status of the following PCI slots is always “Online.”  
 ID: 0/10/102, 0/10/103, 1/11/102, 1/11/103

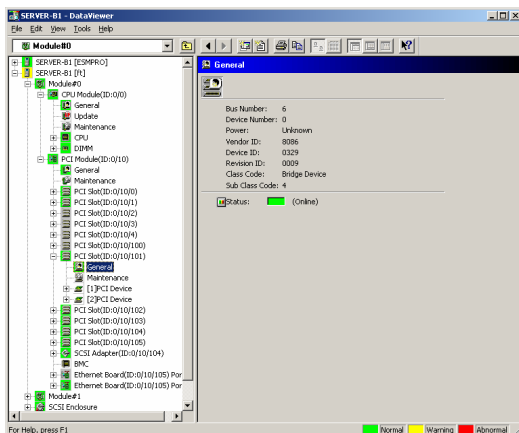

- Maintenance

Allows a device on the PCI slot to be started. This function is not supported in the current version.

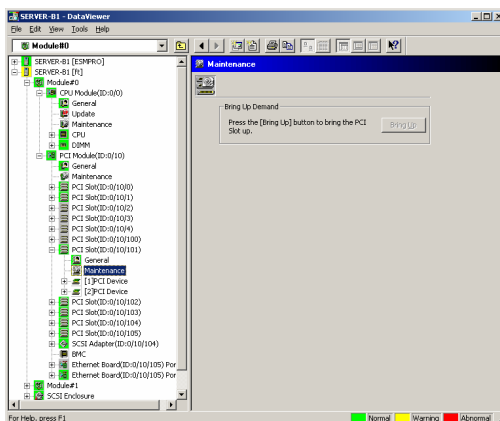

- PCI Device – General

Allows the information of devices on the PCI slot to be viewed.

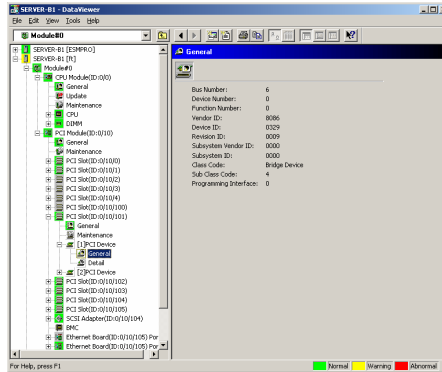

- PCI Device – Detailed information

Allows the detailed information of a device on the PCI slot to be viewed.

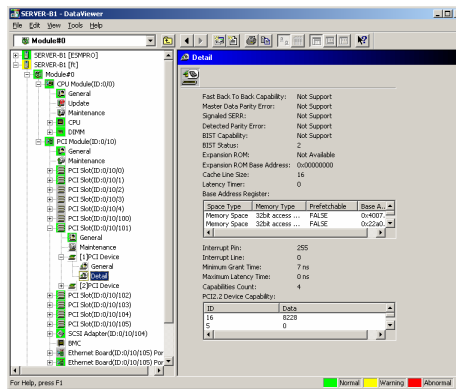

### Monitoring BMC on IO Module

To monitor the base management controller (BMC), controller for system management, on the IO modules, see the [BMC] tree. To see the information on the [BMC] tree, select [PCI Module] - [PCI module (containing BMC to be seen)] - [BMC] of the [ft] tree. You can see the BMC's firmware version and other information in the [BMC] tree.

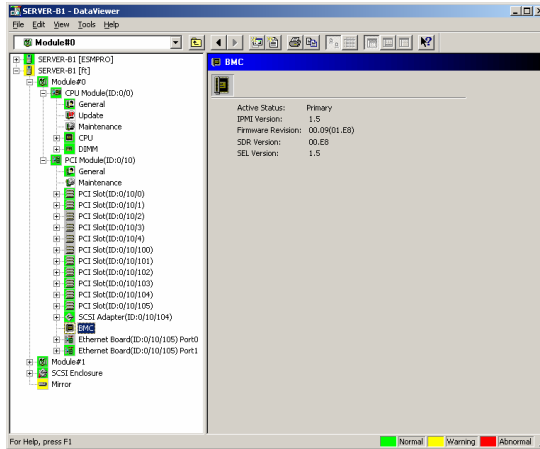

## Monitoring SCSI Enclosure

To monitor the SCSI enclosure, see the [SCSI enclosure] tree. To see the information on the [SCSI enclosure] tree, select [SCSI enclosure] of the [ft] tree.

You can see the following information of the SCSI enclosure from the [SCSI enclosure] tree.

- General

Allows the configuration and other information of the SCSI enclosure to be viewed.

---

### IMPORTANT:

You need to be aware that PCI modules, SCSI adapters, SCSI buses, and modules under the SCSI enclosure have impact on each other. For details, see “Impact of Module Status Changes” described above.

---

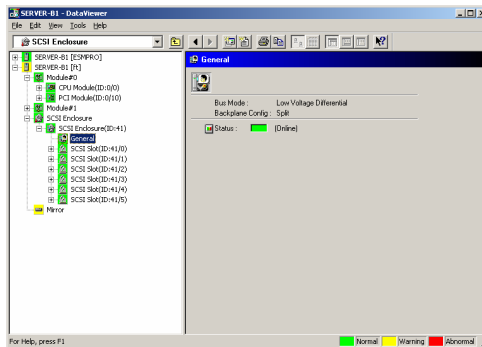

- SCSI Slot – General

Allows the configuration and other information of the SCSI slot to be viewed.

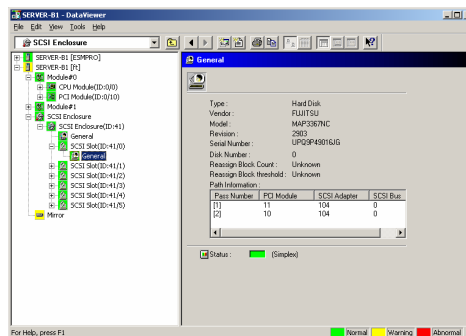

---

### IMPORTANT:

You need to be aware of the status of hard disk during the mirror creation. For details, see “Status Color after Mounting a Hard Disk” in “Supplement.”

---

## Monitoring Mirror Disk

To monitor the mirror disk components, see the [Mirror] tree. To view information on [Mirror] tree, select [Mirror] under [ft] tree.

You can see the redundancy status of the mirrors and the device IDs of the SCSI slots into which these hard disk components are connected.

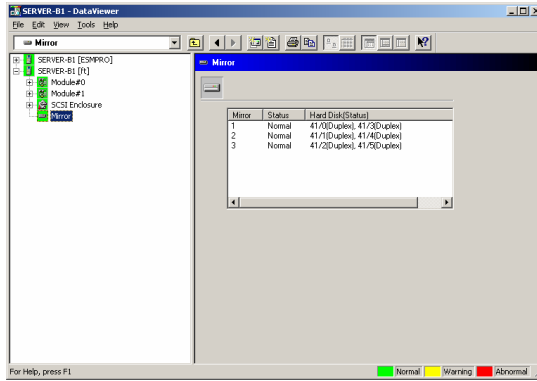

[Mirror]

## Monitoring Hard Disk

To monitor the hard disks and detect disk failures at an early stage, use the NEC ESMPRO Manager and Agent. You can see configurations and information of hard disk in the Data Viewer.

## Monitoring Operations

This section describes how to maintain hard disks.

### 1. Confirmation of hard disk failure

If NEC ESMPRO Agent detects some problem with a hard disk, it will report an alert of the problem to NEC ESMPRO Manager. Check the alert viewer in the manager regularly.

Ex. If a hard disk in SCSI Slot (41/1) is broken, agent reports the following alert.

Status of the SCSI Slot (ID:41/1) has changed from Duplex to Broken.

And manager displays the problem information of the hard disk in the [ft] → [SCSI enclosure] → [SCSI Slot] → [General] of the data viewer.

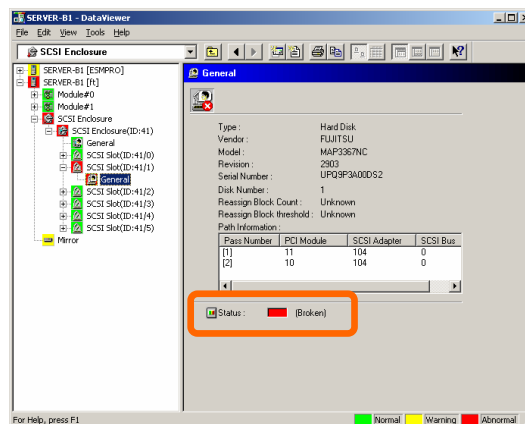

[General] of SCSI slot

**4. Confirmation of mirror status**

To check the redundancy status of the failed mirror disk, open [Mirror] screen under [ft]. On this screen, you can check the redundancy status of the mirror and the status of the mirrored hard disks.

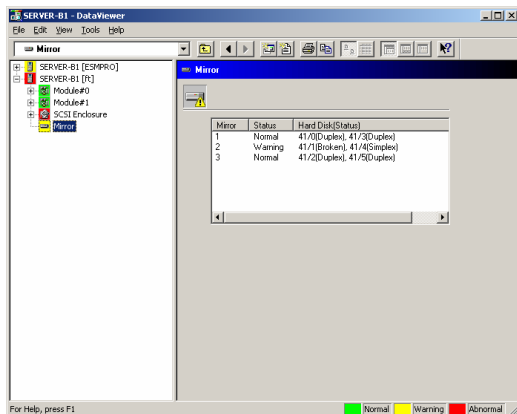

[Mirror]

**IMPORTANT:**

The mirroring redundancy status will change depending on the status of the two hard disks that make up a mirror as follows:

Status of hard disk 1	Status of hard disk 2	Status of mirror volume
Duplex	Duplex	Normal
	Simplex	Warning
	Others	Warning
Simplex	Duplex	Warning
	Simplex	Warning
	Others	Warning
Others	Duplex	Warning
	Simplex	Warning
	Others	-

“-”: No status is shown.

**TIPS:**

Unless the hard disks make up a mirror, the Mirror Disk screen does not show any information.



**IMPORTANT:**

The Mirror Disk screen shows a pair of two hard disks as a mirror. Disk pairs are shown in the same manner even if a few volumes are created within a single disk or one volume spans a few disks (span volume).

- A few volumes are created within a single disk:

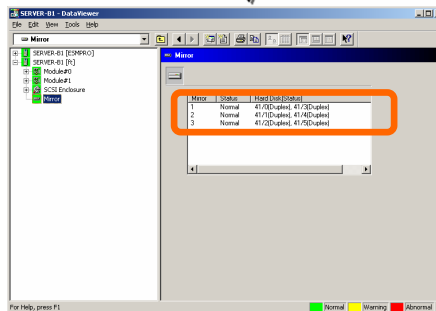
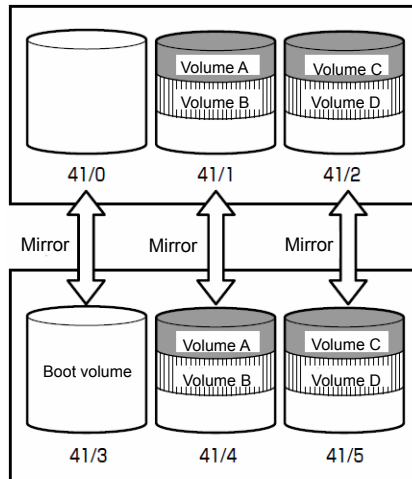

The screen shows information on a pair of hard disks that make up a mirror. It does not show information based on volumes (ex. Volume A, Volume B).

## 5. Recovery from a hard disk failure

If a hard disk breaks, the broken disk must be replaced immediately. This section describes alert reports and status shown by the Data Viewer while disks are replaced to restore mirroring.

### (1) Detecting problem of a hard disk

See [1. Confirm of hard disk failure] above.

### (2) Removing the hard disk

Disconnect the hard disk with the problem. At this time, NEC ESMPRO Agent reports the following alert to manager. And icons related to the hard disk with problem change the state of warning in the data viewer.

Since the hard disk has been removed, the status of the SCSI slot will be “EMPTY.”

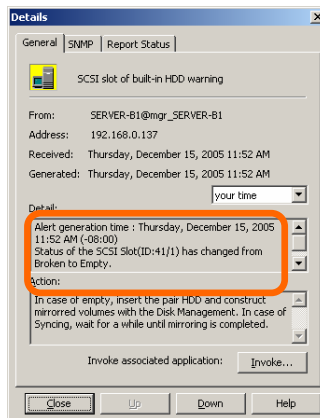

---

### TIPS:

You can identify the new hard disk by DevicePathID (ex. 41/1).

---

When one hard disk with problem was disconnected, SCSI slot changes the status to "Warning."

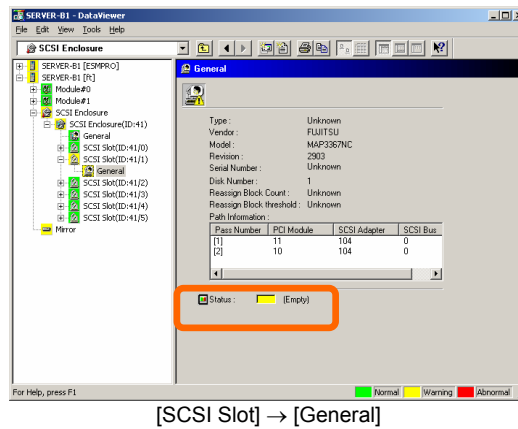

### IMPORTANT:

The status color of the SCSI slot differs depending on the connection of mirrored hard disks:

- If one of the mirrored disks was removed: Warning
- If both of the mirrored disks were removed: Gray

Also, at this time, the redundant status of mirrored disks is changed to "Warning."

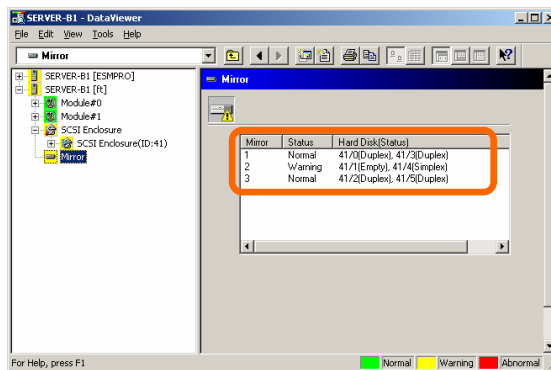

(3) Mounting a hard disk drive.

Mount a hard disk drive. When a hard disk drive is inserted, an alert report is sent and the information on a Data Viewer changed.

A hard disk drive is mounted and the SCSI slot status becomes “Online.”

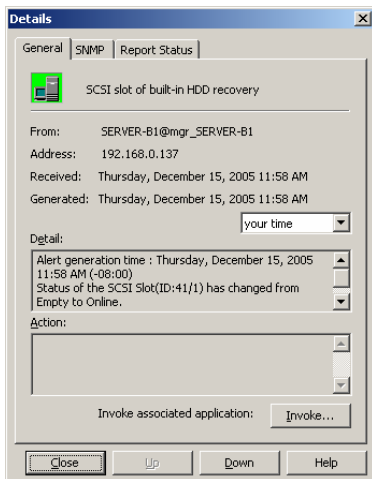

[Details] of alert report

**TIPS:**

The device ID (for example, “41/1”) on the “Details” window of alert indicates the location of the removed hard disk drive.

The state color becomes “Green” because a hard disk drive constructing a mirror is mounted.

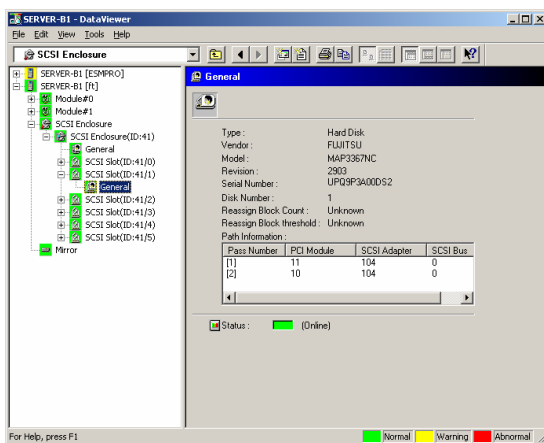

[General] of SCSI Slot

The redundancy status becomes “Normal” because the hard disk drive constructing a mirror is mounted.

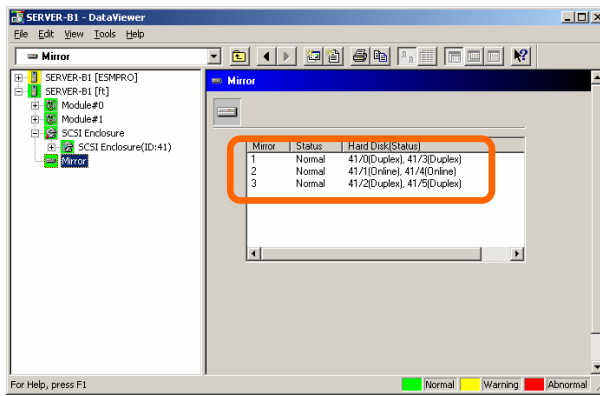

[Mirror]

---

## Server Maintenance Utility

Server Maintenance Utility is a tool for managing server operation. It is used to configure operation patterns, to check status at replacement of parts, and to instruct operations.

- ◆ How to start NEC ESMPRO Agent Server Maintenance Utility that is installed on NEC Express5800/ft series server

1. Move to the directory where the NEC ESMPRO Agent is installed.

```
cd /opt/nec/esmpro_sa
```

2. Move to the directory where the Server Maintenance Utility is stored.

3. Start the tool:

```
./svmntnutl
```

- ◆ For using the Server Maintenance Utility in Japanese, run the command below before starting it. This command starts X Window and the screen will be displayed in the Japanese fonts.

```
init 5
```

If you start the Server Maintenance Utility without starting the X Window, messages displayed on the console may affect the screen display. If the screen is not displayed properly, press **Ctrl** + **L** to refresh the screen.

## Screen Layout

Tree view: Information display view

Component screen: Displays information of the item that you selected in the tree in a new window.

## System Information

Chassis Information contains the following information:

<b>Item</b>	<b>Description</b>
Type	Chassis type of the server
Part Number	Parts number of the server chassis
Serial Number	Serial number of the server chassis

System Information contains the following information:

<b>Item</b>	<b>Description</b>
OS(Ver)	Name of the OS installed on the server, and version of the OS installed on the server
Name	Host name of the server

Product Information contains the following information:

<b>Item</b>	<b>Description</b>
Manufacturer	Manufacturer of the server
Product	Product name of the server
Serial Number	Serial number of the server
Version	Version number of the server

LCD contains the following information:

<b>Item</b>	<b>Description</b>
Module #0	Virtual LCD information of the module #0
Module #1	Virtual LCD information of the module #1

## System Configuration

System Configuration contains the following information:

### **Quick dump that is harvested at the same time of system reboot.**

Select the [Enable] radio button to obtain quick dump at a system crash.

When a quick dump cannot be produced, a dump is produced by the standard dump function.

### **Automatic firmware update.**

Select the [Enable] radio button to enable automatic firmware update. When this item is enabled and when one module is started, the firmware (System BIOS) of the other module started later will be automatically updated to the one that is already running if it is old.

### **Automatic module start.**

Select the [Enable] radio button to enable the automatic module start. When this item is enabled and when the server is running in the simplex mode with one module, if the other module is inserted to the chassis, it will be automatically started and modules will become duplex.

The module POWER switch of the server is always enabled regardless of this setting. (The module stopped by the module POWER switch can be started even when this setting is disabled.)

The following buttons are displayed for System Configuration:

Item	Description
Apply	Applies the system configuration to the server
Default	Resets the system configuration of the server to the default.

These operations cannot be performed while collecting dump or updating firmware. Wait until such processing is finished to perform the operations in the table.

## Module#n

Module contains the following information:

Item	Description
Device	CPU module name and PCI module name
Status	Status of the CPU module and the PCI module

## CPU Module(ID:n/m)

CPU Module contains the following information:

Item	Description
Status	Status of the CPU module



MTBF Information contains the following information:

Note: The MTBF information is displayed only when the [<MTBF Info>] button is pressed.

Item	Description
Type	Monitoring status of MTBF. Use Threshold: MTBF is calculated at a fault occurrence. The device is stopped when the calculated value is lower than the threshold. Never Restart: Always stops the device at a fault occurrence. Always Restart: Always restarts the device at a fault occurrence.
Threshold	Threshold of MTBF.
Current	Current MTBF value.
Faults	Number of faults
Time of last fault	Time of the last fault. When there is none, "--" is displayed.

Firmware contains the following information:

Item	Description
Version	Version of the firmware (System BIOS)
Additional	Additional information of the firmware (System BIOS)

The version information of the firmware is displayed only when the [<Version>] button is pressed.

The following buttons are displayed for CPU Module:

Item	Description
MTBF Info	Displays MTBF information
Clear	Clears the MTBF information of the CPU module
Up	Starts the CPU module. When you also start the PCI module of the same module, start the PCI module before the CPU module.
Down	Stops the CPU module
Version	Displays the version of the firmware
Update	Updates the firmware (System BIOS)
Switch	Switches the board. Start the IO module and the CPU module of the sopped module respectively and make modules duplex. Then, stop the other module's CPU module and IO module respectively. * Use this function when updating the firmware (BIOS). This function is available for a module which CPU and PCI (IO) modules are stopped.
Harvest	Collects dump. Before clicking this button, select one of the methods of to collect dump: <ul style="list-style-type: none"> <li>• Save memory dump of the stopped module.</li> <li>• Harvest memory dump of the current system without stopping it.</li> </ul> * Do not start or stop the module while producing a dump.

- \* (1) The execution of each button may take a few minutes. Wait for a while to update the display and check the module status.
- (2) This system performs diagnostics to both CPU module and PCI module on the same board. Execute diagnostics from a PCI module.
- (3) These operations cannot be performed while collecting dump or updating firmware. Wait until such processing is finished to perform the operations in the table.

**PCI Module(ID:n/m)**

PCI Module contains the following information:

The MTBF information is displayed only when the [**<MTBF Info>**] button is pressed.

Item	Description
Status	Status of the PCI module

MTBF Information contains the following information:

Item	Description
Type	Monitoring state of MTBF. Use Threshold: MTBF is calculated at a fault occurrence. The device is stopped when the calculated value is lower than the threshold. Never Restart: Always stops the device at a fault occurrence. Always Restart: Always restarts the device at a fault occurrence.
Threshold	Threshold of MTBF.
Current	Current MTBF value.
Faults	Number of faults
Time of last fault	Time of the last fault. When there is none, "--" is displayed.

Diagnostics Information contains the following information:

Item	Description
Time of last run	Time and date of the last diagnostics execution
Message	Message from the diagnostics result
Test No.	Test number from the diagnostics result

The following buttons are displayed for PCI Module:

Item	Description
MTBF Info	Displays MTBF information
Clear	Clears the MTBF information of the PCI module
Up	Starts the PCI module. The CPU module of the same module must be stopped when starting the PCI module. When the CPU module of the same module is running, stop the CPU module and then start it after starting the PCI module.
Down	Stops the PCI module. Depending on a module state, a screen will go off temporarily. Also, USB devices such as a keyboard and a mouse may not be available for a few minutes. However, a system continues operating. You cannot stop the module when the FT status LED is not illuminating green (when the server is not duplicated).
Diagnose	Executes diagnostics of the CPU module on the same module as the PCI module. To perform diagnostics, both CPU and PCI modules on the module needs to be stopped.

- \* (1) The execution of each button may take a few minutes. Wait for a while to update the display and check the module status.
- (2) These operations cannot be performed while collecting dump or updating firmware. Wait until such processing is finished to perform the operations in the table.

**SCSI Adapter(ID:n/m/o)**

SCSI Adapter contains the following information:

Item	Description
Status	Status of the SCSI adapter

**SCSI Bus(ID:n/m/o/p)**

The following information is displayed for SCSI Bus:

Item	Description
Status	Status of the SCSI bus (Primary or Secondary)

The following information is displayed for SCSI Bus:

Item	Description
Change	Makes the current bus the primary SCSI bus (For your maintenance personnel).

\* The execution of each button may take a few minutes. Wait for a while to update the display and check the module status.

**Ethernet Board(ID:/n/m/o) Port p**

The following information is displayed for Ethernet Board:

Item	Description
Status	Status of the Ethernet board

**BMC**

The following information is displayed for Firmware:

Item	Description
Active Status	Current status of the firmware
IPMI Version	IPMI version
Firmware Revision	Firmware revision
SDR Version	SDR version
SEL Version	SEL version

**SCSI Enclosure**

The following information is displayed for SCSI Enclosure:

Item	Description
Device	SCSI enclosure name
Status	Status of the SCSI enclosure

### SCSI Enclosure(ID:n)

The following information is displayed for SCSI Enclosure:

Item	Description
Status	Status of the SCSI enclosure

The following information is displayed for SCSI Slot:

Item	Description
Slot	SCSI slot name
Status	Status of the SCSI slot

- \* The last digit of SCSI slots corresponds to the slot number of built-in SCSI disk.  
For the rack-mount model: 0 through 5 from bottom to top.  
For tower model: 0 through 5 from right to left.

### SCSI Slot (ID:n.m)

The following information is displayed for SCSI Slot:

Item	Description
Status	Status of the SCSI slot (individual built-in SCSI disk)

The following information is displayed for SCSI Bus:

Item	Description
Path State	State of the two SCSI buses connected to individual internal SCSI disks.
PCI Module	PCI module number
SCSI Adapter	SCSI adapter number
SCSI Bus	SCSI bus number

## Firmware Update

The following information is displayed for Firmware Update:

### Copy online BIOS image to offline.

Select this radio button to copy online BIOS image to offline.

### Specify the file path to update.

Select this radio button to specify the file path to update.

### Type the location of the firmware.

Type the full path (location and the file name) of the firmware to update in the edit box.

The following buttons are displayed for Firmware Update:

Item	Description
Execute	Updates the firmware *Do not perform the following operations during the update of firmware. - Start/stop of a module - OS shutdown - Module removal - Module power-off *Firmware can be updated from an old version to a new version only. It cannot be updated if its version number is equal to or smaller than the one of both modules of the system whose firmware you want to update.
Cancel	Cancels firmware update

## Key Operations

### Arrow keys

Use the up or down arrow key (↑ or ↓) to move up or down the selection of the tree item when the focus is on the tree view. For items with “+” or “-,” use the left or right arrow key (← or →) to expand or close the tree.

### Space key

When the focus is on the tree view, use the space key to expand or close items with “+” or “-” on the tree. When the focus is on the component screen, use the space key to check a radio button.

### Tab key

When the focus is on the tree view, use the Tab key to move to the [Exit] button. When the focus is on the component screen, use the Tab key to move to the next selection item.

### Enter key

When the focus is on the tree view, use the Enter key to display the component screen of a component.

## Maintenance of NEC Express5800/ft series

The server maintenance can be done in two ways; one is to use NEC ESMPRO Manager for remote maintenance and the other is to use the NEC ESMPRO Agent Server Maintenance Utility on the server for local maintenance.

### TIPS:

- How to start NEC ESMPRO Agent Server Maintenance Utility that is installed on NEC Express5800/ft series server
  1. Move to the directory where the NEC ESMPRO Agent is installed.  
`cd /opt/nec/esmpro_sa`
  2. Move to the directory where the Server Maintenance Utility is stored.
  3. Start the tool:  
`./svmntnutil`
- For using the Server Maintenance Utility in Japanese, run the command below before starting it. This command starts X Window and the screen will be displayed in the Japanese fonts.  
`init 5`

If you start the Server Maintenance Utility without starting the X Window, messages displayed on the console may affect the screen display. If the screen is not displayed properly, press **Ctrl + L** to refresh the screen.

The maintenance functions that can be executed from NEC ESMPRO include three types, those common to all components, those specific to particular components, and general system settings.

The maintenance functions common to all components are operated in the same way basically (the operation procedure and typical examples of screen images are described below).

The table below lists the maintenance functions common to all components.

Component	Start		Stop		MTBF clear		Diagnosis		F/W update	
	R	L	R	L	R	L	R	L	R	L
CPU module	√	√	√	√	√	√	-	-	√	√
IO module	√	√	√	√	√	√	√	√	-	-
PCI slot	-	-	-	-	-	-	-	-	-	-
Ethernet board	-	-	-	-	-	-	-	-	-	-
SCSI adapter	-	-	-	-	-	-	-	-	-	-
SCSI enclosure	-	-	-	-	-	-	-	-	-	-
SCSI electronics	-	-	-	-	-	-	-	-	-	-
SCSI slot	-	-	-	-	-	-	-	-	-	-

- R: Remote. Executable from remote management PC by using NEC ESMPRO Manager
- L: Local. Executable on local server by using Server Maintenance Utility
- √: Support
- : Not support

The maintenance operations in the table cannot be performed while collecting dump or updating firmware. Wait until such processing is finished to perform the operations in the table.

The table below shows the component-specific maintenance functions executable from NEC ESMPRO.

Component	Dump acquisition		Dump acquisition during system operation		Board switch	
	R	L	R	L	R	L
CPU module	–	√	√	√	√	√

R: Remote. Executable from remote management PC by using NEC ESMPRO Manager  
 L: Local. Executable on local server by using Server Maintenance Utility  
 √: Support  
 –: Not support

Component	Change of primary SCSI bus	
	R	L
SCSI bus	–	√

R: Remote. Executable from remote management PC by using NEC ESMPRO Manager  
 L: Local. Executable on local server by using Server Maintenance Utility  
 √: Support  
 –: Not support

Component	BMC firmware update	
	R	L
BMC	√	√

R: Remote. Executable from remote management PC by using NEC ESMPRO Manager  
 L: Local. Executable on local server by using Server Maintenance Utility  
 √: Support  
 –: Not support

The table below shows the support of the whole system setup functions.

Component	Quick dump		Automatic firmware update		Automatic module start	
	R	L	R	L	R	L
Whole system	–	√	–	√	–	√

R: Remote. Executable from remote management PC by using NEC ESMPRO Manager  
 L: Local. Executable on local server by using Server Maintenance Utility  
 √: Support  
 –: Not support

## Start and Stop of Components

To start or stop a component with NEC ESMPRO Manager, use the [Maintenance] tree of the component in the [ft] tree of the data viewer. Open the tree of the component to be started or stopped and select the [Maintenance] tree.

To start or stop a component with the Server Maintenance Utility, use the component screens of the Server Maintenance Utility.

The table below shows the potential cases in which a component is to be started or stopped.

Component	Start		Stop	
	Remote	Local	Remote	Local
CPU Module	When the cause of down is reviewed and the system is restarted in module down state.  Executable in any of the following module states (this can be viewed on manager screen): <ul style="list-style-type: none"> <li>• Removed</li> <li>• Broken</li> <li>• Shot</li> <li>• Firmware Update Complete</li> <li>• Diagnostics Passed</li> </ul>	When the cause of down is reviewed and the system is restarted in module down state.  Executable in the following module state: (this can be viewed on Server Maintenance Utility screen) <ul style="list-style-type: none"> <li>• Removed</li> <li>• Broken</li> <li>• Shot</li> <li>• Firmware Update Complete</li> <li>• Diagnostics Passed</li> </ul>	When system is stopped forcibly due to replacement or malfunction of module.  Executable in the following module state (this can be viewed on manager screen): <ul style="list-style-type: none"> <li>• Duplex</li> </ul>	When system is stopped forcibly due to replacement or malfunction of module.  Executable in the following module state: (this can be viewed on Server Maintenance Utility screen) <ul style="list-style-type: none"> <li>• Duplex</li> </ul>
IO Module	Same as above	Same as above	Same as above	Same as above

Remote: Executable from remote management PC by using NEC ESMPRO Manager

Local: Executable on local server by using Server Maintenance Utility

---

### IMPORTANT:

IO modules, SCSI adapters, SCSI buses, and modules under the SCSI enclosure have impact on each other. You need to be aware of this, for example, when you replace a CPU/IO module. For details, see “Impact of Module Status Changes” described earlier in this chapter.

When starting modules, ensure to start IO modules first and then CPU modules. To start IO modules when CPU modules are running and IO modules are stopped, the CPU modules must be stopped before starting IO modules.

---

### CHECK:

Even if stoppage of a CPU module or IO module is requested, the module will not be stopped if it is judged that the system would be unable to continue running. It is the same for when the FT STATUS LED is off.

For example, the module is not stopped when the CPU/IO modules are successfully duplicated,



but the link cable of a teamed LAN is connected to only one side of the modules or when a storage device connected by FC is connected to only one side of the modules.

---

### Procedure in NEC ESMPRO Manager

#### ■ Start

1. Select the target component in the [ft] tree.
2. Check the current state with the "State" display on the target component screen.
3. Click the [Bring Up] button in the [Maintenance] screen for the target component.

A certain time is required for the start.

The start result can be confirmed by "State" on the target component screen. The result of the start operation is reported by the server as an alert.

---

#### **CHECK:**

When starting a stopped IO module, diagnostics of the CPU/IO modules are automatically performed. The IO module is started after the diagnostics.

---

#### ■ Stop

Perform the procedure below before replacing a component.

1. Select the target component in the [ft] tree.
2. Check the current state with the "State" display on the target component screen.
3. Click the [Bring Down] button in the [Maintenance] screen for the target component.

A certain time is required for the stop.

The stop result can be confirmed by "State" on the target component screen. The result of the stop operation is reported by the server as an alert.

---

#### **CHECK:**

When stopping IO module, check that the status of Ethernet is "Duplex" on NEC ESMPRO Manager. Do not stop the IO module especially when LAN is connected only to the IO module on that side.

---

### Sample screen of NEC ESPRO Manager 1

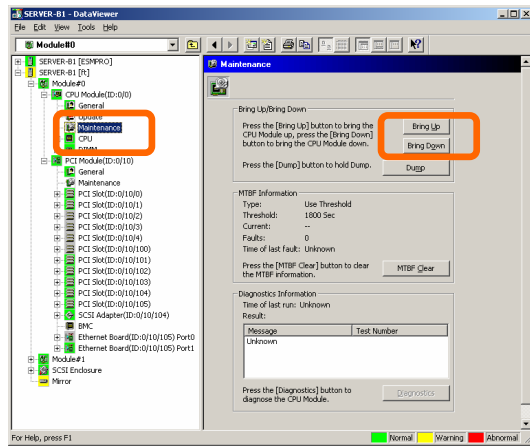

[Maintenance] screen of CPU module  
 [CPU Module] – [CPU Module] – [Maintenance]

### Sample screen of NEC ESPRO Manager 2

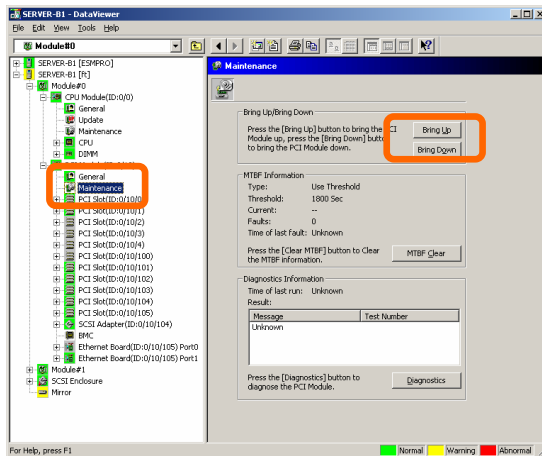

[Maintenance] screen of IO module  
 [PCI Module] – [Maintenance]

## Procedure in the Server Maintenance Utility

### Start

1. Select the target component from the main window of the Server Maintenance Utility.  
The screen of the target component appears.

2. Check the current state of the target component with the LEDs.

3. Select [Up] of the target component.

A certain time is required for the start.

The start result can be confirmed by the LEDs on the target component. The result of the start operation is registered in the syslog.

### Stop

Stop before replacing components.

1. Select the target component from the main window of the Server Maintenance Utility.  
The screen of the target component appears.

2. Check the current state of the target component with the LEDs.

3. Select [Down] of the target component.

A certain time is required for the start.

The start result can be confirmed by the LEDs on the target component. The result of the start operation is registered in the syslog.

## Sample screen of Server Maintenance Utility

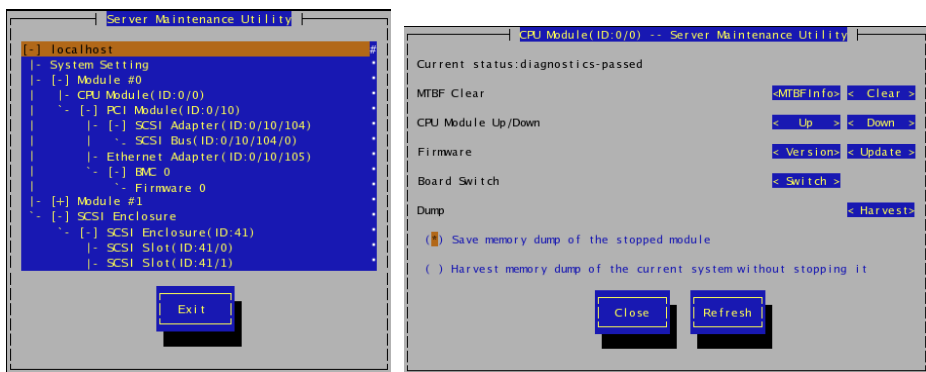

Main window

[CPU Module] screen

### Check and Clear of MTBF Information

The MTBF information of a component can be viewed or cleared (initialized).

The server manages the MTBF (mean time between failures) of each component. If a fault occurs in a component, the server series calculates the MTBF of the component again. If the calculated value is lower than the pre-defined threshold, the server disables the component to be used. Contact your maintenance personnel if such a symptom as above occurs.

---

#### IMPORTANT:

A disabled component with the MTBF lower than the threshold can be forcibly enabled by clearing the MTBF. However, contact your maintenance personnel for the forced use of such a component.

---

To clear the MTBF information of a component with NEC ESMPRO Manager, use the [Maintenance] tree of the component of the [ft] tree of the data viewer. Open the tree of the component whose MTBF information is to be cleared and select the [Maintenance] tree.

To clear the MTBF information of a component with the Server Maintenance Utility, use the component screens of the Server Maintenance Utility. The table below shows the potential cases in which the MTBF information of a component is to be cleared. Contact your maintenance personnel for clearing MTBF information.

Component	MTBF clear	
	Remote	Local
CPU Module	To start the module forcibly after replacing a module or if MTBF became lower than the threshold due to malfunction and disabled the module.	To start the module forcibly after replacing a module or if MTBF became lower than the threshold due to malfunction and disabled the module.
IO Module	Same as above	Same as above

Remote: Executable from remote management PC by using NEC ESMPRO Manager  
 Local: Executable on local server by using Server Maintenance Utility

## Procedure in NEC ESMPRO Manager

Perform the procedure below before replacement of a component.

1. Select the target component in the [ft] tree.
2. Check the current state with the "State" display on the target component screen.
3. Click the [Clear] button in the [MTBF Clear] of the target component.

The MTBF clearing result can be confirmed by the MTBF information on the target component screen. The result of the MTBF clearing operation is reported by the server as an alert.

### CHECK:

- At this point, the "State" display on the target component screen is not changed.
- If the MTBF clear is executed in the following conditions, diagnostics of the CPU/IO modules are automatically performed after MTBF clear:
  - The target CPU/IO module is turned on
  - Both of the target CPU module and IO module are stopped

4. Start the component.

### CHECK:

At this point, the "State" display on the target component screen is changed.

## Sample screen of NEC ESMPRO Manager

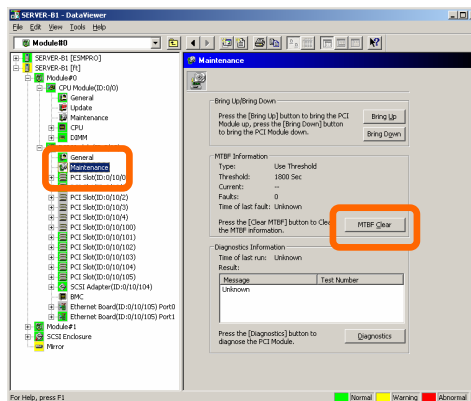

[Maintenance] screen of IO module  
[PCI module] – [Maintenance]

### Procedure in the Server Maintenance Utility

Perform the procedure below before replacement of a module.

1. Select the target module from the main window of the Server Maintenance Utility.  
The screen of the target module appears.
2. Check the current state of the target module with the LEDs.
3. Select [Clear] in [MTBF Clear] of the target module.  
You can confirm the MTBF clear result by checking the LEDs of the target component. The result is registered in the syslog.
4. Start the component.

### Sample screen of Server Maintenance Utility

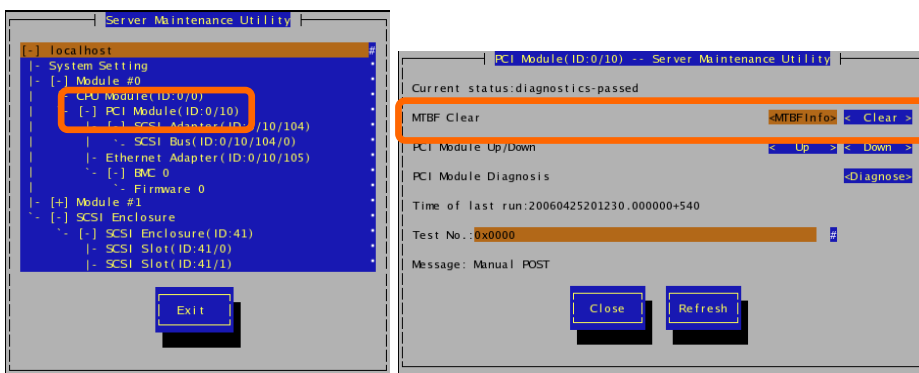

Main window

[PCI Module] screen

## Diagnostics

The server provides the self-check diagnostics function for some components. If a fault occurs in a component, the server can diagnose the component to detect the fault.

For this server, CPU modules and IO modules can be diagnosed all together.

To diagnose a component with the NEC ESMPRO Manager, use the [Maintenance] tree of the component in the data viewer. Open the tree of the component to be diagnosed and select the [Maintenance] tree.

To diagnose of a component with the Server Maintenance Utility, use the component screens of the Server Maintenance Utility.

The table below shows the potential cases in which a component is to be diagnosed.

Component	Diagnostics	
	Remote	Local
CPU Module	<p>When a phenomenon causing the module to be down occurs or a phenomenon supposed to be a malfunction occurs.</p> <p>Executable in any of the following module states (this can be viewed on manager screen):</p> <ul style="list-style-type: none"> <li>• Removed</li> <li>• Broken</li> <li>• Shot</li> <li>• Firmware Update Complete</li> </ul> <p>To diagnose the module under operation, bring down the module before the diagnostics.</p>	<p>When a phenomenon causing the module to be down occurs or a phenomenon supposed to be a malfunction occurs.</p> <p>Executable in any of the following module states:</p> <p>(This can be viewed on Server Maintenance Utility screen.)</p> <ul style="list-style-type: none"> <li>• Removed</li> <li>• Broken</li> <li>• Shot</li> <li>• Firmware Update Complete (Diagnostics Passed)</li> </ul> <p>To diagnose the module under operation, bring down the module before the diagnostics.</p>

Remote: Executable from remote management PC by using NEC ESMPRO Manager

Local: Executable on local server by using Server Maintenance Utility

---

### IMPORTANT:

Diagnostics operations are performed to IO modules. When IO modules are diagnosed, CPU modules will be diagnosed as well. CPU modules cannot be diagnosed individually.

---

The system diagnostics cannot be performed while collecting dump or updating firmware. Wait until such processing is finished to perform the diagnostics.

**Procedure in NEC ESMPRO Manager**

1. Select the target module in the [ft] tree.
2. Check the current state with the "State" display on the target module screen. If CPU and IO modules of the target module are running, stop them.
3. Click the [Diagnostics] button in the [Maintenance] screen for the IO module of the target module.

When the diagnostics is started, the CPU and IO modules are diagnosed together.

The diagnostics result can be confirmed by "Result" of the diagnostics on the target component screen. The result of the diagnostics is reported by the server as an alert. The result of diagnostics executed last is displayed in the [Diagnostics Information] column. In addition, if a fault is detected by the result of the diagnostics, the state of the [General Information] tree of the component is changed.

**CHECK:**

When stopping IO module, check that the status of Ethernet is “Duplex” on NEC ESMPRO Manager. Do not stop the IO module especially when LAN is connected only to the IO module on that side.

**Sample screen of NEC ESMPRO Manager**

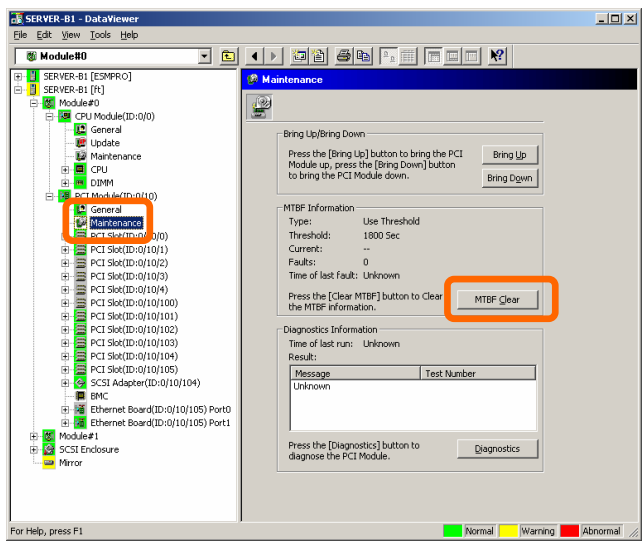

[Maintenance] screen of IO module  
[PCI Module] – [Maintenance]



## Procedure in the Server Maintenance Utility

1. Select a target component from the main window of the Server Maintenance Utility.  
The screen of the target component appears.
2. Check the current state of the target component with the LEDs.
3. Diagnose the component by selecting [Diagnose] in [PCI Module Diagnosis].  
The result can be viewed by reacquiring the status of the component. The result is registered in syslog.

## Sample screen of Server Maintenance Utility

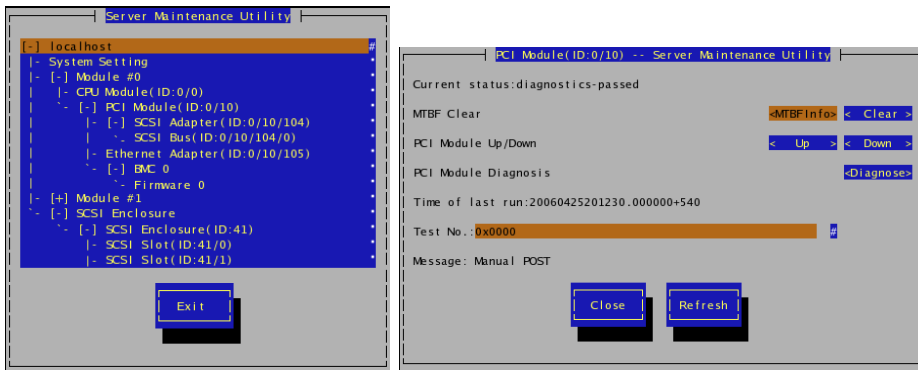

Main window

[PCI Module] screen

## Firmware Update

The server can update firmware (including BIOS) if some hardware components operate in the online state (in which the system continues the operation but the component trying to update firmware or BIOS is stopped).

To update firmware with NEC ESMPRO Manager, use the [Update] tree of the component in the data viewer. Open the tree of the component for which firmware is updated and select the [Update] tree.

To update the firmware of a component with the Server Maintenance Utility, use the component screens of the Server Maintenance Utility.

To update the firmware of a component, the firmware image file of the firmware for update must previously be stored in the managed server. On the firmware update screen, specify the path to the firmware image file for update.

The table below shows the potential cases in which the firmware of a component is to be updated.

Component	Firmware update	
	Remote	Local
CPU Module	<p>When BIOS must be updated to new one.</p> <p>Executable in any of the following module states (this can be viewed on manager screen):</p> <ul style="list-style-type: none"> <li>• Removed</li> <li>• Broken</li> <li>• Shot</li> <li>• Diagnostics Passed</li> </ul> <p>To update the module under operation, bring down the module before the update.</p>	<p>When BIOS must be updated to new one.</p> <p>Executable in the following module state (this can be viewed on Server Maintenance Utility screen):</p> <ul style="list-style-type: none"> <li>• Removed</li> <li>• Broken</li> <li>• Shot</li> <li>• Diagnostics Passed</li> </ul> <p>(Firmware Update Complete)</p> <p>To update the module under operation, bring down the module before the update.</p>

Remote: Executable from remote management PC by using NEC ESMPRO Manager

Local: Executable on local server by using Server Maintenance Utility

## Procedure in NEC ESMPRO Manager

1. Save the image data of the update firmware in an arbitrary directory of the server.  
Write down the path to the directory in which the image data is saved.
2. Select the target component in the [ft] tree.
3. Check the current state with the "State" display on the target component screen. If the component is operating, stop the component. Stop the CPU module and then stop the PCI module.
4. Click the [Firmware Update] button in the [Update] screen for the target component.

## Sample screen of NEC ESMPRO Manager

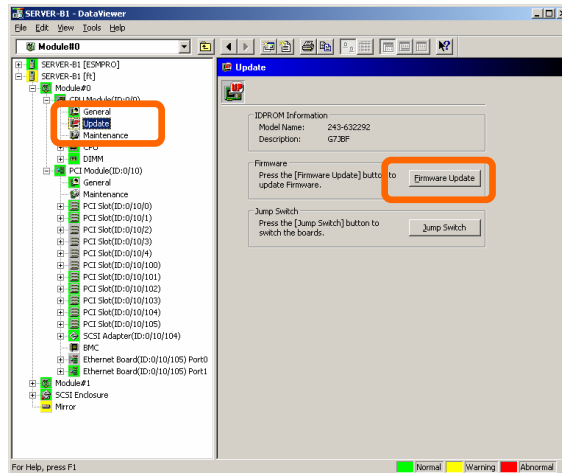

[Update] screen of CPU module  
[CPU Module] – [Update]

5. Select [Specify the file path to update], enter the directory where the firmware to update is stored (the directory you wrote down in step 1) and the file name of the image data into the input box, and click the [Execute] button.

The server will update the firmware.

The update result can be confirmed by the state on the target component screen (indication of "Firmware update completed"). The result of the update processing is reported by the server as an alert.

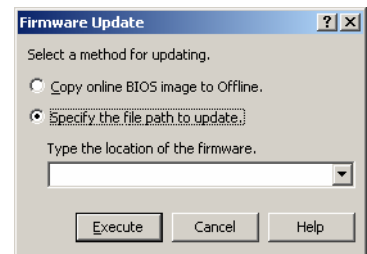

6. After the BIOS for a single CPU module is completed, click the [Jump Switch] button. The module completely updated is started and the active module is stopped.

The result of switching boards is reported as an alert. Switching boards should be performed only by "Firmware Update." The keyboard and mouse may not function for a few minutes while switching boards.

If the module is not switched successfully, you can continue to the next step by clicking

[Down] of the module you want to stop.

7. Click [Diagnostics] on the [Maintenance] screen of the other PCI module stopped.
8. Start the other stopped module.

Starting the module causes the firmware to be updated automatically. However, if the [Enable automatic firmware update] property is disabled, the module is started but the firmware will not be updated. In such a case, perform the following operations before starting the module:

- (1) Click the [Firmware Update] button in the [Update] screen for the target component.
- (2) In the [Firmware Update] dialog box, select [Copy online BIOS image to Offline] as a method for updating, and click [Execute].

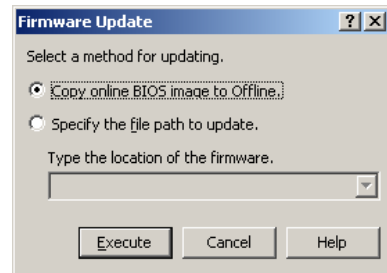

---

**IMPORTANT:**

A message prompting you to reconstruct the tree of Data Viewer you are updating may appear. In such a case, click [Yes].

---

**CHECK:**

When stopping IO module, check that the status of Ethernet is “Duplex” on NEC ESMPRO Manager. Do not stop the IO module especially when LAN is connected only to the IO module on that side.

---

**Procedure in the Server Maintenance Utility**

1. Enable “Automatic module start” and “Automatic firmware update.”  
See “Setup of System Operation” in this chapter for the procedure to enable.
2. Store the image data of the firmware for update in the NEC Express5800/ft series.  
Save it in the /etc directory under the name “BIOS.ROM.”
3. On the main window of the Server Maintenance Utility, select the target component.  
The screen of the target component appears.
4. Check the current state of the target component with the LEDs. If the component is running, stop the component.
5. Select [Update] of [Firmware].  
The [Firmware Update] screen appears.
6. Select [Specify the file path to update.], type “/etc/BIOS.ROM” as the file path, and then select [Execute].  
The firmware update will be performed. After the firmware update has completed, the target component automatically starts and the other stops.

---

**IMPORTANT:**

If “Automatic firmware update” is disabled, the target component will not start and the firmware update will not complete. In such case, perform the firmware update again after enabling “Automatic firmware update.”

---

7. The other component will start automatically and the firmware will be updated automatically.

---

**IMPORTANT:**

If “Automatic module start” is disabled, the target component will not start automatically. In such case, start the component manually. The firmware will be updated automatically.

---

8. When BIOS of one CPU module is updated, select [Switch] in [Board Switch]. The updated module will be started and the module currently running will be stopped. Use [Board Switch] only when updating firmware. While switching boards, the keyboard and the mouse will be unavailable for few minutes.  
If the modules were not switched due to the system state, you can continue to the next step by selecting [Down] in [CPU Module Up/Down] of the module you want to stop.
9. Diagnose the stopped PCI module.
10. Start the module.

### Sample screen of Server Maintenance Utility

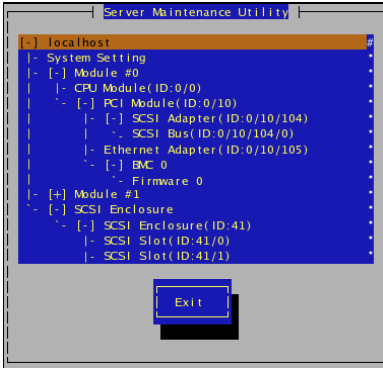

Main window

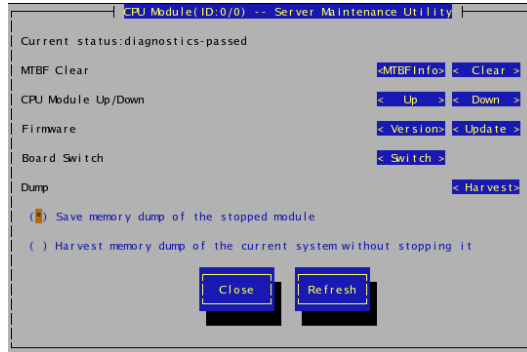

[CPU Module] screen

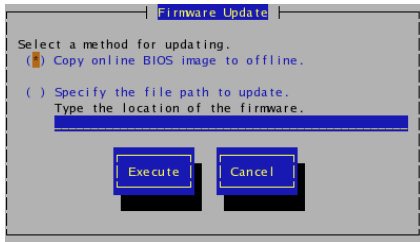

[Firmware Update] screen

Even if you do not have the image data of firmware for update, the firmware can be copied from the other module.

By starting the module, the firmware will be updated automatically. However, when the [Automatic firmware update] property is disabled, follow the steps below to update the firmware:

1. Start the system using the module of the firmware copy source.  
Check the status LEDs of the copy destination component for its current status. If it is running, stop it.
2. On the [Update] screen of the target component, select [Firmware update].
3. When the [Firmware Update] screen appears, check [Copy online BIOS image to offline] and execute it.

Firmware is updated by copying the firmware on the online side to the offline side.

## Dump Collection

To collect the dump file with NEC ESMPRO Manager, use [CPU Module] →[Maintenance] tree in the data viewer.

To collect the dump with the Server Maintenance Utility, use the utility screen of the component.

---

### **IMPORTANT:**

Collect dump only for the purpose of failure investigation.

---

- Collecting dump of inactive module

The dump is acquired from the inactive CPU module (Broken or Shot).

The dump can be collected only when the power is supplied with the module POWER LED illuminating and both CPU module and IO module are stopped.

■ Collecting dump under system operation

Either of the CPU modules is entered into the offline state and the dump is collected during system operation. After the acquisition, the CPU module is returned to the online state again. This can be done only in the duplex system.

The table below shows the potential cases in which the dump is acquired.

Component	Saving dump of stopped module		Saving dump of component under system operation	
	Remote	Local	Remote	Local
CPU Module	–	When a fault or malfunction occurs in the system. Save the dump if requested by maintenance personnel. Executable in the following module state: (this can be viewed on Server Maintenance Utility screen) <ul style="list-style-type: none"> <li>• Removed</li> <li>• Broken</li> <li>• Shot</li> <li>• Firmware Update Complete</li> <li>• Diagnostics Passed</li> </ul>	When a fault or malfunction occurs in the system. Save the dump if requested by maintenance personnel. Executable in the following module state (this can be viewed on manager screen): <ul style="list-style-type: none"> <li>• Duplex</li> </ul>	When a fault or malfunction occurs in the system. Save the dump if requested by maintenance personnel Executable in the following module state: (this can be viewed on Server Maintenance Utility screen) <ul style="list-style-type: none"> <li>• Duplex</li> </ul>

Remote: Executable from remote management PC by using NEC ESMPRO Manager

Local: Executable on local server by using Server Maintenance Utility

–: Not support



## Procedure in the Server Maintenance Utility

1. On the main window of the Server Maintenance Utility, select the target component.  
The screen of the target component appears.
2. Check the current status of the target CPU module with the LEDs.
3. Select a dump acquisition method on the CPU module screen, and select [Harvest].  
A certain time is required for the dump acquisition. The dump is stored to the system defined location on the server.  
The result of the dump acquisition can be registered in the syslog.
4. Start the component.

## Sample screen of Server Maintenance Utility

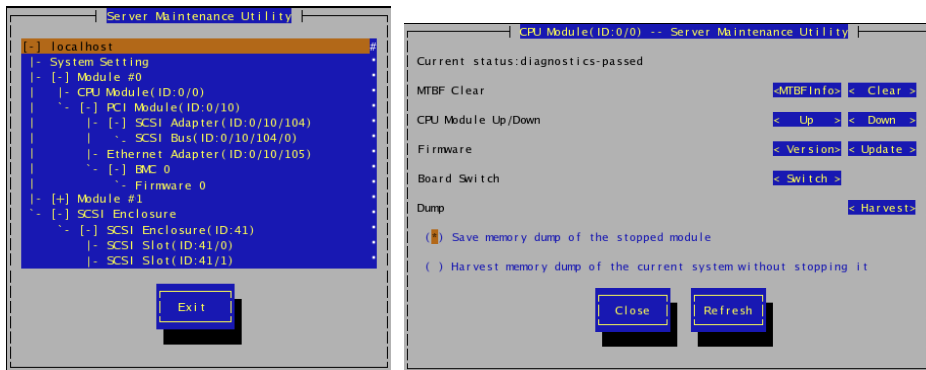

Main window

[CPU Module] screen

## Setup of System Operation

The following properties can be set as the operation setup of the whole system.

- Quick dump that is harvested at the same time of reboot

If “Enable” is selected for this item, dump is collected as the system reboots when an error occurs in the system. When “Disable” is selected, dump is collected by the OS standard dump function.

The default value is “Enable.”

- Automatic firmware update

If “Enable” is selected for this item, the BIOS of the new CPU module is updated to the BIOS of the existing CPU module to match with each other. If “Disable” is selected, the BIOS of the new CPU module is not updated automatically.

The default value is “Enable.”

- Automatic module start

If “Enable” is selected for this item, modules will be put into the duplex mode automatically when mounting both modules and restarting the system. If “Disable” is selected, the modules will not be in the duplex mode.

The default value is "Enable."

Settings can be made in the [System Configuration] window of Server Maintenance Utility.

The table below shows the potential cases in which the system operation setup is changed. Contact your maintenance personnel for the change of the system operation setup. Setting change will take effect after system reboot. However, the utility does not indicate that reboot is required.

The system operation settings cannot be made while collecting dump or updating firmware. Wait until such processing is finished to make the settings.

Component	Quick dump		Automatic firmware update		Automatic module start	
	Remote	Local	Remote	Local	Remote	Local
Whole system	–	Executable if the system is operating.  When dump is acquired by using the dump function normally installed in OS at occurrence of system fault.	–	Executable if the system is operating.  When firmware is updated manually at insertion of new module	–	Executable if the system is operating.  When firmware is started manually at insertion of new module

Remote: Executable from remote management PC by using NEC ESMPRO Manager

Local: Executable on local server by using Server Maintenance Utility

–: Not support

Configure the system settings using the Server Maintenance Utility in the following procedure. The system cannot be configured using the NEC ESMPRO Manager.

1. Select [System Setting] on main window of the Server Maintenance Utility. The [System Setting] screen is displayed.
2. Change the properties on the [System Setting] screen.
3. Select [Apply].

### Sample screen of Server Maintenance Utility

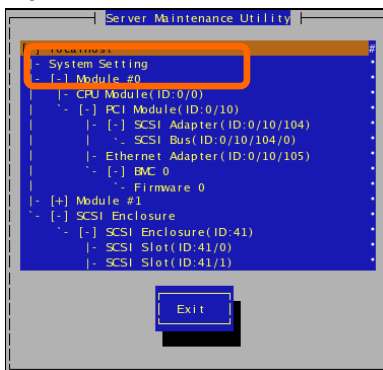

Main window

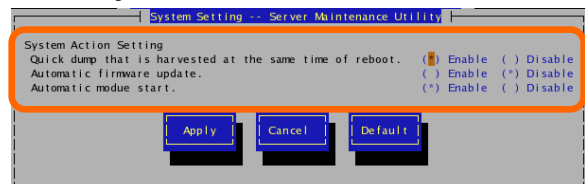

[System Setting] screen

## BMC Firmware Update

The firmware of the BMC on the PCI module can be updated.

The base management controller (BMC) is the processor exclusively used for monitoring the system's operating environment faults and controlling of the system.

The BMC firmware can be updated by using the BMC firmware update utility.

Both NEC ESMPRO Manager and the Server Maintenance Utility can start the BMC firmware update utility.

To update the BMC firmware, the firmware image file must be updated on the managed server in advance. On the BMC firmware update screen, specify the path of the image file of the firmware to be updated.

The table below shows the potential cases in which the BMC firmware is to be updated.

---

### IMPORTANT:

Contact your maintenance personnel for the update of the BMC firmware.

---

Component	BMC firmware update	
	Remote	Local
BMC	When an update to new firmware is required. Executable in the following module state (this can be viewed on manager screen): <ul style="list-style-type: none"> <li>● Duplex</li> </ul>	When an update to new firmware is required. Executable in the following module state (this can be viewed on Server Maintenance Utility screen) <ul style="list-style-type: none"> <li>● Duplex</li> </ul>

Remote: Executable from remote management PC by using NEC ESMPRO Manager

Local: Executable on local server by using Server Maintenance Utility

—: Not support

## Procedure of Update from NEC ESMPRO Manager Menu

Update firmware in the procedure as follows:

1. Select [Tools]→[BMC FW Update Utility] from the Operation Window's menu.

The [BMC FW Update] dialog box appears.

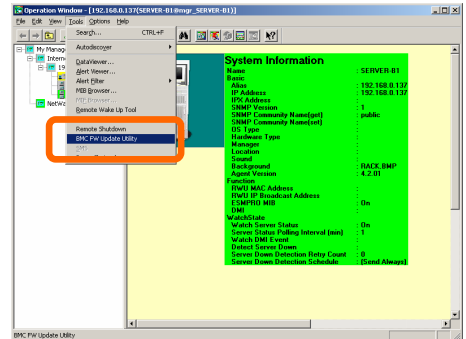

2. Enter the device name and click [OK].  
The [Execution Check] dialog box appears.

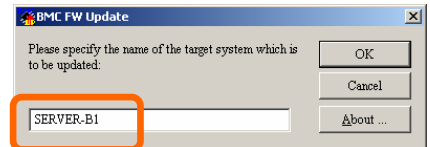

3. Store the firmware in the directory specified by [Location].  
The storage area may be modified. See "Changing Update Data Storage Destination" described later.

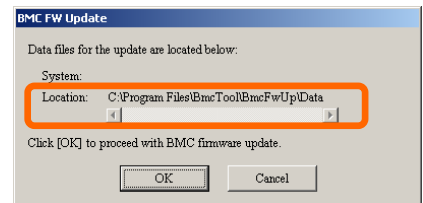

4. Click [OK].  
Run firmware update.  
The advance of the update appears during update.  
At the termination of update, the update result is displayed.

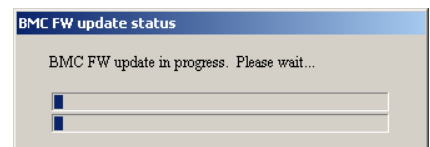

5. Click [OK].

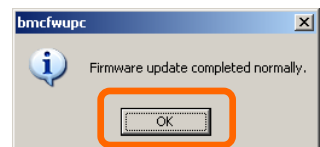

### Procedure of Update from the Server Maintenance Utility

Update the firmware in the procedure as follows.

1. Select [Firmware] on the main window of the Server Maintenance Utility.

The [Firmware Update] screen appears.

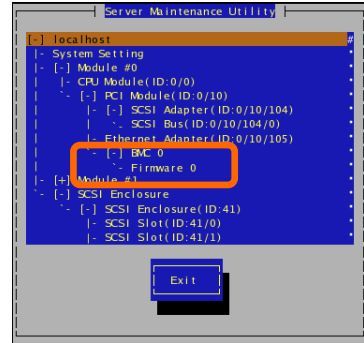

2. Select [Update].

The [BMC FW update Tool] screen appears.

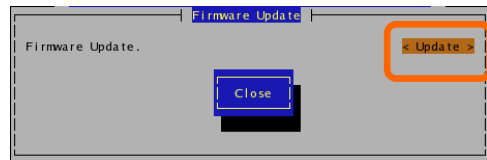

3. Select [BMC FW update Command] menu, and press **Enter**.

The firmware will be updated.

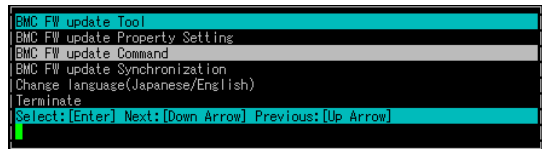

## Changing Update Data Storage Destination

Change the storage destination by using the Server Maintenance Utility in the procedure below.

1. Select [Firmware] on the main window of the Server Maintenance Utility.

The [Firmware Update] screen appears.

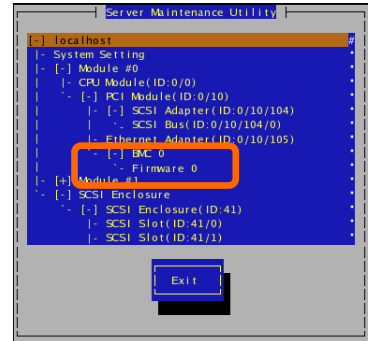

2. Select [Update].

The [BMC FW update Tool] screen appears.

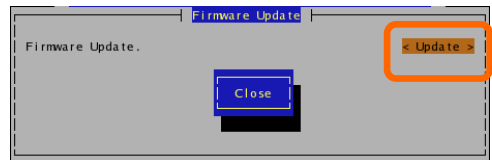

3. Select [BMC FW update Property Setting] menu, and then press **Enter**.

The [BMC FW update Service Property Setting] screen appears.

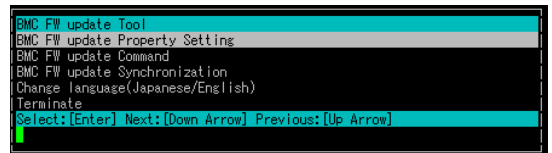

4. Enter the storage destination in [Data File Path], and then click [Data save and Exit].

If you click [Cancel and Exit], the property setting will be finished with the updated data canceled.

The confirmation message for the storage is displayed.

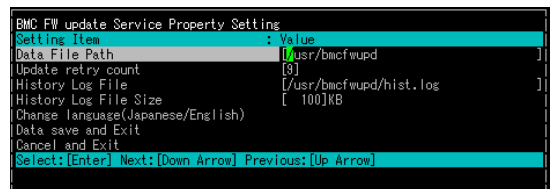

5. Press **Y** to store. Press **N** not to store.

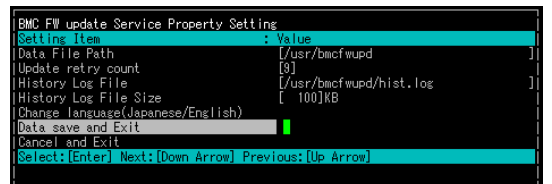

## NEC DianaScope

NEC DianaScope is software for remote management of the server. For features and installation of NEC DianaScope, see “NEC DianaScope Online Document” in “NEC EXPRESSBUILDER.”

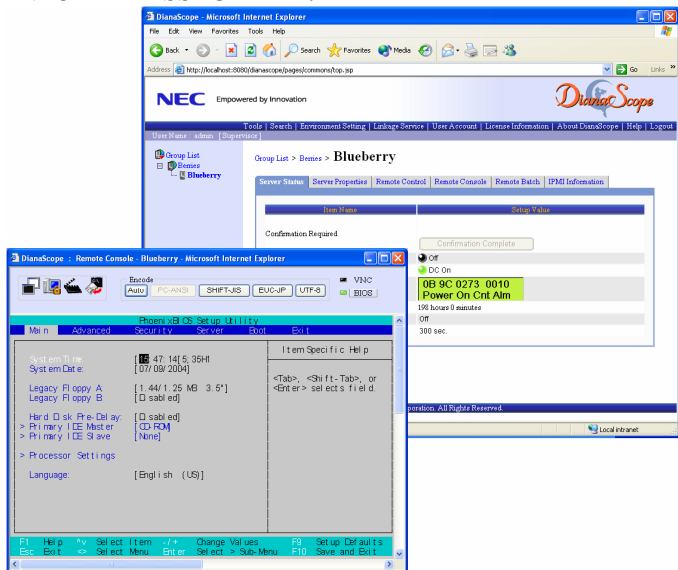

### TIPS:

To use NEC DianaScope with the server, appropriate server license is required.

- UL1198- 001E DianaScope Additional Server License (1)  
License for managing one server.
- UL1198- 011E DianaScope Additional Server License (10)  
License for managing ten servers.

ft Remote Management Card comes with one license of NEC DianaScope.

### Notes

The online document provides general descriptions of overall servers to be remotely managed by NEC DianaScope, but this section indicates notes that require special attention for remotely managing this server using NEC DianaScope.

- The server can be managed remotely only when ft Remote Management Card is installed.
- When remotely managing this server from NEC DianaScope, only LAN connection is available. Direct connection and connection via modem are not supported.
- NEC DianaScope cannot power off, power cycle or reset the server. The server does not support such functions.



# Chapter 6

---

## Maintenance

This chapter describes the daily maintenance of NEC Express5800/ft series and precautions when relocating or storing the server.

# DAILY MAINTENANCE

To use your NEC Express5800/ft series in best condition, check and maintain regularly as described below. If an error is found on your NEC Express5800/ft series, consult your sales agent.

## Checking Alert

Monitor the failure occurrence by NEC ESMPRO during the system operation.

Always check whether any alert is reported to NEC ESMPRO Manager on the management PC. Check whether any alert is reported on the Operation Window, Data Viewer, or Alert Viewer of NEC ESMPRO Manager.

### Viewers of NEC ESMPRO

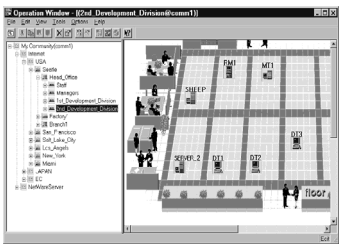

Operation Window

Severity	C	R	Type	Manager	Component	Address	Received
Slot State			Security	mgr_199H27	199H27	140.0.0.27	02/14/2000
Slot State			Security	mgr_199H27	199H27	140.0.0.27	02/14/2000
HW eventing			Server Recov...	mgr_199H27	199H27	140.0.0.27	02/14/2000
Power Unit Redu...			RPS	mgr_199H27	199H27	140.0.0.27	02/09/2000
Power Unit Redu...			RPS	mgr_199H27	199H27	140.0.0.27	02/09/2000
Power Supply Error			RPS	mgr_199H27	199H27	140.0.0.27	02/09/2000
Power Supply Error			RPS	mgr_199H27	199H27	140.0.0.27	02/09/2000

Alert Viewer

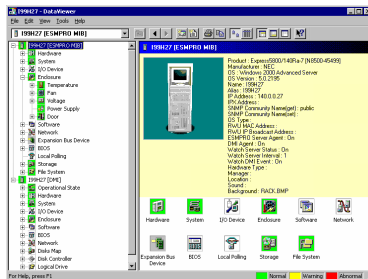

Data Viewer

## Checking STATUS LEDs

Check the LED indication on the front of the NEC Express5800/ft series, on hard disks installed in 3.5-inch hard disk drive bay, or on LCD display when the server is powered on or powered off by the shut down operation. The functions and indications of LEDs are described in Chapter 2. If any indication that shows an error, contact your sales agent.



## Making Backup Copies

NEC recommends you make backup copies of your valuable data stored in hard disks of the server on a regular basis. For backup storage devices suitable for the server and backup tools, consult with your sales agent.

When you have changed the hardware configuration or BIOS configuration, select "System Information Management" and then "Save" of the Off-line Maintenance Utility to make a backup copy of the system information.

## Cleaning

Clean the server on a regular basis to keep the server in a good shape.

 <b>WARNING</b>	
	<p>Observe the following instructions to use the server safely. There are risks of death or serious personal injury. See "PRECAUTIONS FOR SAFETY" in Chapter 1.</p> <ul style="list-style-type: none"> <li>• Do not disassemble, repair, or alter the server.</li> <li>• Do not look into the CD-ROM drive.</li> <li>• Disconnect the power plug before cleaning the server.</li> </ul>

### Cleaning the NEC Express5800/ft series

For daily cleaning, wipe the external surfaces of the server with a dry soft cloth. Follow the procedure below if stains remain on the surfaces:

---

#### **IMPORTANT:**

- To avoid altering the material and color of the server, do not use volatile solvents such as thinner or benzene to clean the server.
  - The power receptacle, the cables, the connectors on the rear panel of server, and the inside of the server must be kept dry. Do not moisten them with water.
- 

1. Make sure that the server is powered off.
2. Unplug the power cord of the server from a power outlet.
3. Wipe off dust from the power cord plug with a dry cloth.
4. Soak a soft cloth in neutral detergent that is diluted with cold or warm water, and squeeze it firmly.
5. Rub off stains on the server with the cloth prepared in Step 4.
6. Soak a soft cloth in water, squeeze it firmly and wipe the server with it once again.

7. Wipe the server with a dry cloth.
8. Wipe off dust from the fan exhaust opening on the rear of the server with a dry cloth.

## Cleaning the Keyboard and Mouse

---

### IMPORTANT:

A keyboard and a mouse use USB interface. Therefore, it is not necessary to power off the server when connecting or disconnecting them.

---

Disconnect the keyboard from the server while the devices in the system (the server and the peripheral devices) remain turned on. Wipe the keyboard surface with a dry cloth. Then connect the keyboard to the server.

The mouse operation depends on the degree of smoothness of the internal ball rotation. To keep the mouse ball clean, use the mouse in a place with little dust. Follow the steps below to clean the mouse regularly:

1. Disconnect the mouse from the USB hub of the keyboard while the server remains powered on.
2. Turn the mouse upside down, and rotate the mouse ball cover counterclockwise to remove it. Take out the ball from the mouse.

3. Wipe the mouse ball with a dry soft cloth.

If stains remain, use a soft cloth to wipe them off. Soak the soft cloth in neutral detergent that is diluted with water or warm water, and squeeze it firmly,

4. Wipe three small rollers inside the mouse with cotton swab.

Use the cotton swab soaked with alcohol if stains remain.

5. Put the mouse ball back into the mouse.

If the mouse or rollers are wet in steps 3 and 4, put it back after fully dried.

6. Place the mouse ball cover, and rotate it clockwise until it is locked.

7. Connect the mouse to the server (the USB hub of the keyboard).

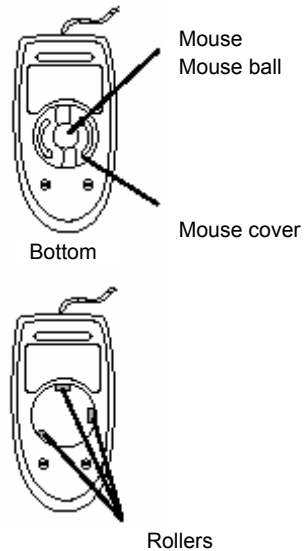

---

## Cleaning the Floppy Disk Drive

A read/write error may occur due to stains on the read/write head of the floppy disk drive.

Use the cleaner dedicated for floppy disk drive to clean the read/write head. It is recommended to clean the head on regular basis.

## Cleaning CD-ROM

A dusty CD-ROM or dust-accumulated tray causes the device to fail to read data correctly.

Follow the procedure below to clean the tray and CD-ROM regularly:

1. Make sure that the server is powered on.
2. Press the Eject button on the front of the CD-ROM drive.  
The tray comes out.
3. Hold the CD-ROM lightly and take it out from the tray.

---

**IMPORTANT:**

Do not touch the signal side of the CD-ROM with your hand.

---

4. Wipe the tray with a dry soft cloth.

---

**IMPORTANT:**

Do not wipe the lens of the CD-ROM drive. Doing so may damage the lens and may cause a malfunction of the drive.

---

5. Gently push on the tray front to close the tray.
6. Wipe the signal side of the CD-ROM with a dry soft cloth.

---

**IMPORTANT:**

Wipe CD-ROMs from the center to the outside. Use only CD-ROM cleaner if necessary. Cleaning a CD-ROM with record spray/cleaner, benzene, or thinner causes damage to the CD-ROM contents. At worst, inserting the CD-ROM into the server may cause failure.

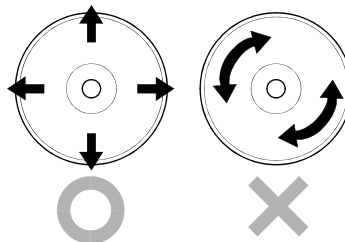

## **Cleaning Tape Drive**

Dirt on the tape head may be a cause of unsuccessful backup and damage to tape cartridge. Clean the tape head regularly using a cleaning tape. For procedure and interval of cleaning as well as lifetime of a tape cartridge to use, see instructions included with the tape drive.

## SYSTEM DIAGNOSTICS

The System Diagnostics runs several tests on the server.

Select [Tools] - [System Diagnostics] in the NEC EXPRESSBUILDER to diagnose the system.

---

### Test Items

The following items are tested in system diagnostics.

- Memory
- CPU cache memory
- Hard disk drive used as a system

---

#### IMPORTANT:

When executing the system diagnostics, make sure to remove the LAN cable. Executing the system diagnostics with the LAN cable connected, the network may be influenced.

---

#### TIPS:

On checking the hard disk drive, no data is written into the disk.

---

---

### Startup and Exit of System Diagnostics

Follow the steps below to start the system diagnostics. (If the server is running, shut it down, and execute Step 1 through Step 12.)

1. Shutdown the OS, and power off the server. Then, unplug the power cord.
2. Disconnect all the LAN cables from the server.
3. Plug the power cord and power on the server.
4. Use the NEC EXPRESSBUILDER CD-ROM to start the system.

Refer to “NEC EXPRESSBUILDER” of Chapter 5 “Installing and Using Utilities,” to start the system properly. “NEC EXPRESSBUILDER Top Menu” is displayed on the screen, when starting the system from the NEC EXPRESSBUILDER.



NEC EXPRESSBUILDER Top Menu

5. Select [Tools].
6. Select [System Diagnostics].

The system diagnostics starts and will be completed in approximately three minutes.

When the diagnostics is completed, the screen of the display changes as shown below:

Diagnostics tool title

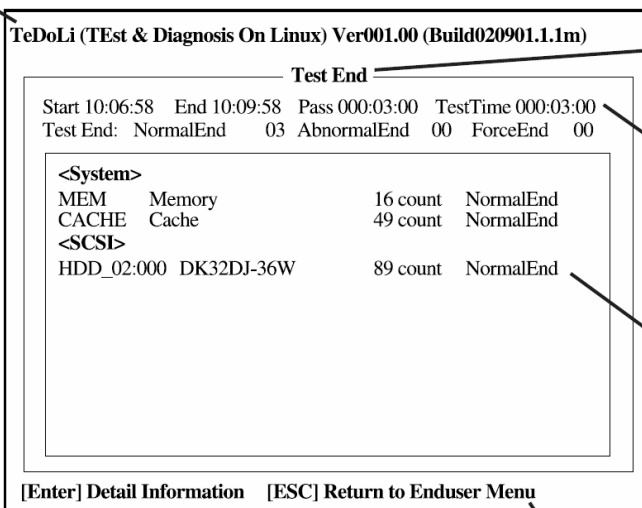

Test window title

Test result

Test summary window

Guideline

**Diagnostics tool title**

Shows the name and version of the diagnostic tool.

**Test window title**

Shows the progress of the diagnostics. “Test End” is displayed when the diagnostics completes.

**Test result**

Shows the start, end, and elapsed time and completion status of the diagnostics.



### Guideline

Shows the details of the keys to operate window.

### Test summary window

Shows the results of each test that executed the diagnostics. Move the cursor and press the **Enter** key on the cursor line to display the details of the test.

When an error is detected by the system diagnostics, the relevant test result in the test summary window is highlighted in red, and “Abnormal End” is displayed in the result on the right side.

Move the cursor to the test that detected the error, and press the **Enter** key. Record the error message that has been output to the Detail Information screen and contact your sales agent.

- Follow the guideline shown at the bottom of the screen, and press the **Esc** key.

The [Enduser Menu] below is displayed.

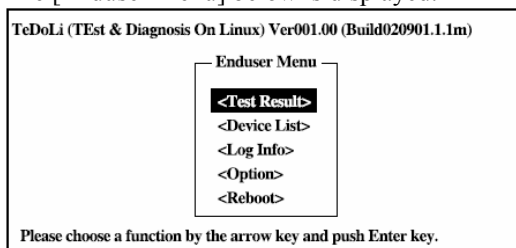

### <Test Result>

Shows the diagnostics completion screen of the above diagnostics.

### <Device List>

Shows a list of connected devices.

### <Log Info>

Shows the log information of the diagnostics. It can be saved on a floppy disk. To save it on a floppy disk, insert a formatted floppy disk to the floppy disk drive, and select <Save(F)>.

### <Option>

Changes the output destination of a log.

### <Reboot>

Reboots the system.

- Select <Reboot> in the [Enduser Menu] above.

The server restarts and the system is started from the NEC EXPRESSBUILDER.

- Exit the NEC EXPRESSBUILDER, and remove the CD-ROM from the CD-ROM drive.

- 10.** Power off the server and unplug the power cord from the receptacle.
- 11.** Reconnect all the LAN cables that have been disconnected in Step 2 to the server.
- 12.** Plug the power cord.

This completes the system diagnostics.

## OFF-LINE MAINTENANCE UTILITY

The Off-line Maintenance Utility is an OS-independent maintenance program. When you are unable to start the OS-dependent NEC ESMPRO to troubleshoot a problem, the Off-line Maintenance Utility can be used.

---

### IMPORTANT:

- The Off-line Maintenance Utility is intended for use of your sales agent. The NEC EXPRESSBUILDER CD-ROM and the Off-line Maintenance Utility Bootable FD you have created contain a file that describes operation of the utility, but do not attempt to use the utility by yourself. Contact your sales agent and follow instructions.
  - Starting the Off-line Maintenance Utility disables any access from a client to the server.
- 

---

### Starting the Off-line Maintenance Utility

The Off-line Maintenance Utility may be started in the following ways.

NEC Express5800/ft series does not support the feature to start the Off-line Maintenance Utility from the maintenance partition.

- From the CD-ROM

Set the NEC EXPRESSBUILDER CD-ROM in the CD-ROM drive and reboot the system. After the menu is displayed on the screen, select [Tools] - [Off-line Maintenance Utility]. The Off-line Maintenance Utility program starts from the CD-ROM.
- From the floppy disk

Set the Off-line Maintenance Utility Bootable FD in the floppy disk drive and reboot the system. The Off-line Maintenance Utility program starts from the boot disk. The Off-line Maintenance Utility Bootable FD is created by selecting [Tools] - [Create Support FD] on the NEC EXPRESSBUILDER.

---

### Features of Off-line Maintenance Utility

The Off-line Maintenance Utility provides the following features.

- IPMI Information Viewer

Provides the functions to view the system event log (SEL), sensor data record (SDR), and field replaceable unit (FRU) and to make a backup copy of them.

Using this feature, you can find system errors and events to determine a maintenance part.
- BIOS Setup Viewer

Provides the functions to export the current configuration data defined with the SETUP utility to a text file.

- System Information Viewer

Provides the functions to view information on the processor (CPU) and the BIOS and export it to a text file.

- System Information Management

Provides the function to make a back-up copy of your data. Without the backup data, the system-specific information and/or configuration may not be restored.

---

**TIPS:**

For information on making backup copy of system information, see the separate volume “User’s Guide (Setup).” Only the authorized personnel are allowed to restore the backup data.

---

- Chassis Identification

Provides the function to distinguish the server using the LEDs or beeps of the server. This function is convenient to distinguish the server from others when multiple servers are on the rack.

## RELOCATING/STORING THE NEC Express5800/ft series

Follow the procedure below to relocate or store the server. (Users should not attempt to remove the rack-mountable server from the rack assembly.)

<b>⚠ CAUTION</b>	
	<p>Observe the following instructions to use the server safely. There are risks of fire, personal injury, or property damage. See “PRECAUTIONS FOR SAFETY” in Chapter 1 for details.</p> <ul style="list-style-type: none"><li>• Never attempt to lift the server only by yourself.</li><li>• Do not install the server in any place other than specified.</li><li>• Do not connect/disconnect any interface cable with the power cord of the server plugged to a power source.</li></ul>

---

### IMPORTANT:

- If the server needs to be relocated/stored due to a change in the floor layout to a great extent, contact the sales agent.
  - Make sure to make a backup copy of your valuable data in the hard disk, if any.
  - When moving the server with hard disks, make sure not to give a shock to the hard disks.
  - When storing the server, keep it under storing environment conditions (temperature: -10 to 55°C, humidity: 20 to 80%, non-condensing).
- 

1. Take a floppy disk and a CD-ROM out of the server, if any.
  2. Power off the server.
  3. Unplug the power cord of the server from a power outlet.
  4. Remove all the cables from the server.
  5. Remove all the mounted modules.
  6. Remove the backplane and the rails from the rack cabinet.
  7. Carry backplane, rails, and modules separately.
  8. Protect the server with the shock-absorbing materials, and pack it securely.
- 

### IMPORTANT:

Check and adjust the system clock before operating the server again after relocating or storing it.

If the server and the built-in optional devices are moved from a cold place to a warm place in a short time, condensation will occur and cause malfunctions and breakdown when these are used in such state. When you start operating these equipments again after the transportation or the storage, make sure to wait for a sufficient period of time to use them in the operating environment.

If the system clock goes out of alignment remarkably as time goes by, though the system clock adjustment is performed, contact your sales agent.

---

(This page is intentionally left blank.)

# Chapter 7

---

## Troubleshooting

If the product does not work properly, see this chapter before deciding that it is a breakdown.

## TO LOCATE THE ERRORS

Use NEC ESMPRO to monitor the occurrence of fault during the system operation.

Especially take note on whether any alert is reported to NEC ESMPRO Manager on the management PC. Check whether any alert is reported on the Operation Window, Data Viewer, or Alert Viewer of NEC ESMPRO Manager.

### [Example]

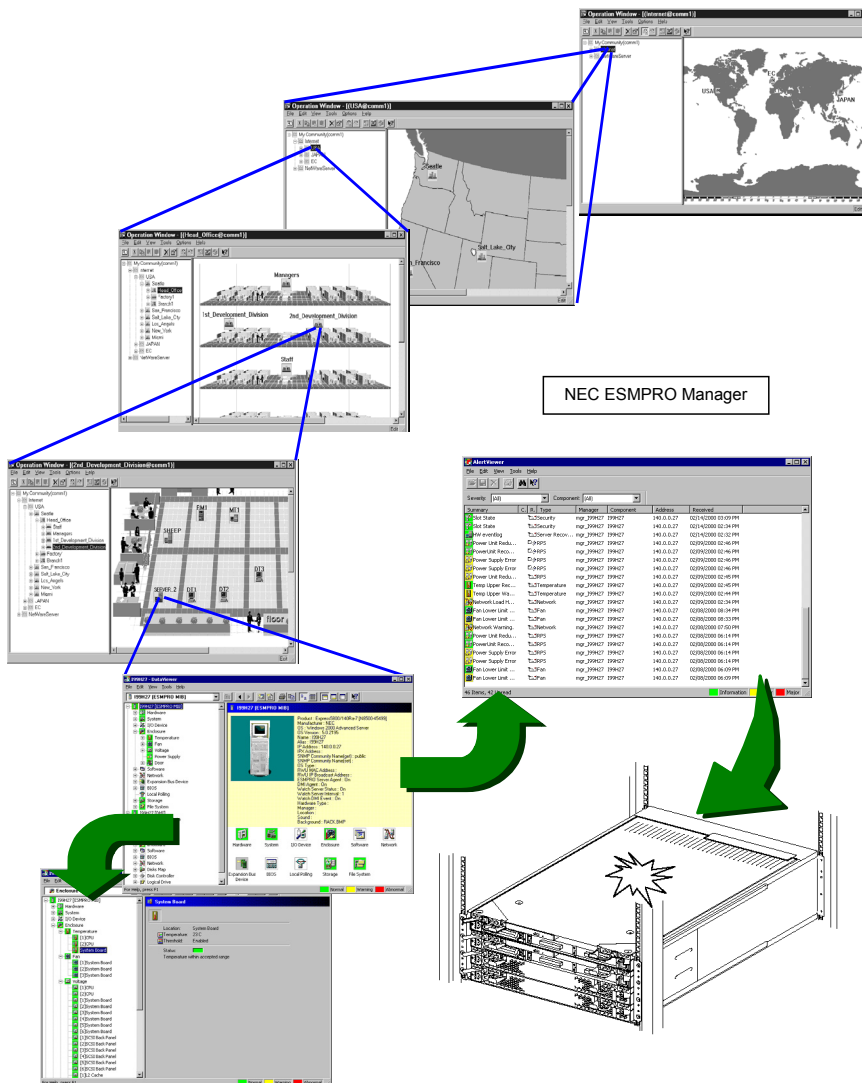

Determine type and location of server/workstation trouble.



## **ERROR MESSAGES**

If the NEC Express5800/ft series enters the abnormal state, the error is posted by various means. This section explains the types of error messages.

---

### **Error Messages by LED Indication**

The LEDs on the front and rear panels of the NEC Express5800/ft series and near the handles of hard disks inform the user of the various server statuses by the colors and the patterns of going on, going off, and flashing. If trouble seems to have occurred, check the LED indication. For the LED indication and meanings, see page 2-22 “LEDs.”

This User’s Guide describes actions to be taken for watch error message. However, if replacement of modules is necessary, contact your sales agent.

## POST Error Messages

Powering on the server automatically starts the self-diagnostic program, POST (Power On Self-Test). When POST detects any error, it displays an error message and its measure on the display unit. Follow the table below to troubleshoot such errors.

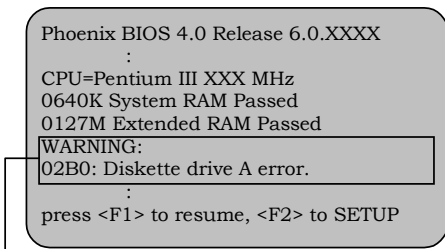

Message indicating a floppy disk drive error

### TIPS:

For error messages on optional PCI boards, refer to the manual provided with those options.

On-screen error message	Cause	Action
0200 Failure Fixed Disk	<ul style="list-style-type: none"> <li>• Hard disk is faulty</li> <li>• CPU/IO module is faulty.</li> </ul>	<ul style="list-style-type: none"> <li>• Replace the hard disk.</li> <li>• Replace the CPU/IO module.</li> </ul>
0210 Stuck Key	Keyboard connection error	<ul style="list-style-type: none"> <li>• Disconnect the keyboard and connect it back again.</li> <li>• Replace the keyboard.</li> </ul>
0211 Keyboard error	Keyboard is faulty.	<ul style="list-style-type: none"> <li>• Disconnect the keyboard and connect it back again.</li> <li>• Replace the keyboard.</li> <li>• If restarting does not help, replace the CPU/IO module.</li> </ul>
0212 Keyboard Controller Failed	Keyboard controller is faulty.	If restarting the server does not help, replace the CPU/IO module.
0213 Keyboard locked - Unlock key switch	Keyboard is locked.	Unlock the key switch.
0230 System RAM Failed at offset	DIMM is faulty.	<ul style="list-style-type: none"> <li>• Replace DIMM.</li> <li>• Replace the CPU/IO module.</li> </ul>
0231 Shadow RAM Failed at offset	Shadow RAM is faulty.	<ul style="list-style-type: none"> <li>• Replace DIMM.</li> <li>• Replace the CPU/IO module.</li> </ul>
0232 Extended RAM Failed at address line	Extended RAM is faulty.	<ul style="list-style-type: none"> <li>• Replace DIMM.</li> <li>• Replace CPU/IO module.</li> </ul>
0233 Memory type mixing detected	Memory of the different types is installed.	Memory of the different types is installed. Replace DIMM with appropriate one.
0250 System battery is dead -Replace and run SETUP	System battery is dead.	<ul style="list-style-type: none"> <li>• Replace system battery.</li> <li>• Replace CPU/IO module.</li> </ul>

<b>On-screen error message</b>	<b>Cause</b>	<b>Action</b>
0251 System CMOS checksum bad-Default configuration used	System CMOS configuration is changed.	<ul style="list-style-type: none"> <li>Reconfigure the system CMOS by using BIOS setup.</li> <li>Clear system CMOS using hardware jumper.</li> </ul>
0252 Password checksum bad -Password cleared	Password is cleared.	<ul style="list-style-type: none"> <li>Reconfigure by using BIOS setup.</li> <li>Clear system CMOS using hardware jumper.</li> </ul>
0260 System Timer error	System Timer is faulty.	Reconfigure by using BIOS setup.
0270 Real time clock error	RTC is faulty.	
0271 Check date and time setting	Date and time are incorrectly set.	
02D0 System cache error - Cache disabled	CPU cache is faulty.	If replacing the CPU does not help, replace the CPU/IO module.
02D1 System Memory exceeds the CPU's caching limit	CPU cache is faulty.	
0613 COM A configuration change	COM A configuration is faulty.	If restarting does not help after resetting the setting to default by using BIOS setup, replace the CPU/IO module.
0614 COM A config, error - device disable	Device constructing COM A is faulty.	
0B28 Unsupported Processor detected on Processor 1	Unsupported CPU is mounted.	Check the supported CPU and replace it. If this does not help, replace the CPU/IO module.
0B29 Unsupported Processor detected on Processor 2	Unsupported CPU is mounted.	
0B60 DIMM group #1 has been disabled	DIMM is faulty.	Replace DIMM Group#1.
0B61 DIMM group #2 has been disabled		Replace DIMM Group#2.
0B62 DIMM group #3 has been disabled		Replace DIMM Group#3.
0B70 The error occurred during temperature sensor reading	I2C pass is faulty. Sensor is faulty.	Replace the part that relevant sensor is mounted.
0B71 System Temperature out of the range	Temperature is abnormal. Fan is abnormal.	Check if fan is faulty or clogging has occurred. If there is no problem, replace CPU/IO module.
0B74 The error occurred during voltage sensor reading	I2C pass is faulty. Sensor is faulty.	Replace the part that relevant sensor is mounted.
0B75 System voltage out of the range	Voltage is abnormal.	If turning AC power off and on does not help, replace the CPU/IO module.
0B80 BMC Memory Test Failed	RMC device is faulty.	Replace the CPU/IO module or ft Remote Management Card (option).
0B81 BMC Firmware Code Area CRC check failed		
0B82 BMC core Hardware failure		

<b>On-screen error message</b>	<b>Cause</b>	<b>Action</b>
0B83 BMC IBF or OBF check failed	RMC device is faulty.	Replace the CPU/IO module or ft Remote Management Card (option).
0B8A BMC SEL area full	There is no space to write system event logs.	Clear system event logs after saving them.
0B8B BMC progress check timeout	BMC check is suspended.	Replace the CPU/IO module or ft Remote Management Card (option).
0B8C BMC command access failed	BMC command access failed.	Replace the CPU/IO module or ft Remote Management Card (option).
0B8D Could not redirect the console - BMC Busy	Console cannot be redirected (BMC is busy).	There is a possibility that the BMC was busy and could not respond. Restart the server again.
0B8E Could not redirect the console - BMC Error	BMC is faulty.	Replace the CPU/IO module or ft Remote Management Card (option).
0B8F Could not redirect the console – BMC parameter Error -	Configuration is faulty.	Configure the console redirection by using BIOS setup.
0B90 BMC Platform Information Area corrupted	BMC device is faulty.	Replace the CPU/IO module or ft Remote Management Card (option).
0B91 BMC update firmware corrupted		
0B92 Internal Use Area of BMC FRU corrupted		
0B93 BMC SDR Repository empty	SDR data is faulty.	If updating SDR does not help, replace the CPU/IO module or ft Remote Management Card (option).
0B94 IPMB signal lines do not respond	SMC is faulty.	Replace the CPU/IO module or a center plane after determining where IPMB error has occurred based on OS information.
0B95 BMC FRU device failure	NVRAM within BMC is faulty.	Replace the CPU/IO module or ft Remote Management Card (option).
0B96 BMC SDR Repository failure	SDR repository within BMC is faulty.	
0B97 BMC SEL device failure	SEL repository within BMC is faulty.	
0B98 BMC RAM test error	BMC RAM is faulty.	
0B99 BMC Fatal hardware error	BMC FPGA is faulty.	If updating FPGA does not help, replace the CPU/IO module or ft Remote Management Card (option).
0B9A BMC not responding	BMC device is faulty.	Replace the CPU/IO module or ft Remote Management Card (option).
0B9B Private I2C bus not responding	I2C bus is faulty.	Replace the part related to failed I2C bus.

On-screen error message	Cause	Action
0B9C BMC internal exception	BMC device is faulty.	Replace the CPU/IO module or ft Remote Management Card (option).
0B9D BMC A/D timeout error		
0B9E SDR repository corrupt	SDR data is faulty.	If updating SDR does not help, replace the CPU/IO module or ft Remote Management Card (option).
0B9F SEL corrupt	SEL repository within BMC is faulty.	Replace the CPU/IO module or ft Remote Management Card (option).
0BA0 SDR/PIA mismatched. SDR, PIA must be updated.	SDR and PIA data do not match.	If updating SDR/PIA does not help, replace CPU/IO module or ft Remote Management Card (option).
0BB0 SMBIOS - SR0M data read error	<ul style="list-style-type: none"> <li>• I2C bus is faulty.</li> <li>• SR0M is faulty.</li> <li>• BMC is faulty.</li> </ul>	If turning AC power off and on does not help, replace the CPU/IO module.
0BB1 SMBIOS - SR0M data checksum bad	Data within SR0M is faulty.	
0BC0 POST detected startup failure of 1st Processor	CPU is faulty.	Replace the CPU.
0BC1 POST detected startup failure of 2nd Processor		
8120 Unsupported DIMM detected in DIMM group #1	Unsupported DIMM is mounted.	Check supported DIMMs and replace the DIMM. If replacing the DIMM does not help, replace the CPU/IO module.
8121 Unsupported DIMM detected in DIMM group #		
8122 Unsupported DIMM detected in DIMM group #3		
8130 Mismatch DIMM detected in DIMM group#1	DIMM group do not match.	
8131 Mismatch DIMM detected in DIMM group#2		
8132 Mismatch DIMM detected in DIMM group#3		
8150 NVRAM Cleared By Jumper	CMOS clear jumper is mounted.	Turn off the DC power and change back the jumper setting.
8151 Password Cleared By Jumper	Password clear jumper is mounted.	
8160 Mismatch Processor Speed detected on Processor 1	CPU frequency does not match.	Check supported CPUs and replace the CPU. If replacing the CPU does not help, replace CPU/IO module.
8161 Mismatch Processor Speed detected on Processor 2		
8170 Processor 1 not operating at intended frequency.	CPU frequency is incorrect.	

On-screen error message	Cause	Action
8171 Processor 2 not operating at intended frequency	CPU frequency is incorrect.	Check supported CPUs and replace the CPU. If replacing the CPU does not help, replace CPU/IO module.
9064 Mixed CPU Steppings detected	Different CPU steppings are found.	
9038 Check date and time settings (Chipset)	Data and time settings are incorrect.	If reconfiguring by using BIOS setup does not help, replace the CPU/IO module.
9001 Missing date and time synchronization	Information delivery among units failed	
9002 Memory not installed.	DIMM is not implemented. DIMM is faulty.	Mount or replace the DIMM.
9003 Memory implementation error detected	Error is detected on memory implementation.	Check supported DIMMs and replace the DIMM. If replacing the DIMM does not help, replace the CPU/IO module.
9004 Real time clock error (Chipset)	RTC is faulty.	Reconfigure RTC by using BIOS setup.
9005 Remote BMC access failed	BMC of remote unit is faulty.	Check again if the CPU/IO module is mounted properly. If this does not help, replace the CPU/IO module.
9006 HW Memory Test failed.	Memory is faulty.	Replace the DIMM. If replacing it does not help, replace the CPU/IO module.
9009 Chipset NMI occurred!	BIOS NMI handler is executed and POST is stopped.	Obtain detailed information, and replace the CPU/IO module.
900A PEXA Link Width Warning	PCI-EX Link is faulty.	Since performance becomes slightly lower, replace the CPU/IO module in case of an emergency.
900B PEXB Link Width Warning		
900D PEXD Link Width Warning		
900E PEXE Link Width Warning		
9021 Trace memory test failed		
902C BMCFW major revision mismatched.	BMCFW revision does not match.	Update SDR/PIA. If updating it does not help, replace the CPU/IO module or ft Remote Management Card (option).
902D IPMB#1 SROM failure detected	IPMB#1 SROM is faulty.	If restarting does not help, replace the CPU/IO module, ft Remote Management Card (option) or center plane.
902E IPMB#2 SROM failure detected.	IPMB#2 SROM is faulty.	
902F PCI Device Test failed.	PCI Device is faulty.	Replace the CPU/IO module.
9060 Module#0 is not present.	CPU/IO module#0 is not mounted.	Mount the primary unit. If restarting does not help, replace the CPU/IO module.
9061 Module#1 is not present.	CPU/IO module#1 is not mounted.	Mount the primary unit. If restarting does not help, replace the CPU/IO module.

On-screen error message	Cause	Action
9039 Not keep last boot order	Unintended operations such as incorrect DC off are performed.	Reconfigure the boot option by using the BIOS setup. If reconfiguring the boot option does not help, replace the CPU/IO module.
9070 The error occurred during water-cooling unit sensor reading	The sensor of water-cooling kit is faulty.	Replace the water-cooling kit. If turning on/off AC does not help, replace CPU/IO module or ft Remote Management Card.
NOTICE System is force boot with POST error	Abnormality of one or both sides of modules is detected.	View other error information and the error information of standby CPU/IO module.
9000	A serious error occurred during a POST.	There are some error messages in addition to this error code. Check the other error message.
9007	Forced power off occurred by another CPU/IO module has a problem.	Pull out another CPU/IO module and install it. If this does not help, replace the CPU/IO module.
9008	Forced power off occurred by another CPU/IO module has a problem.	Pull out another CPU/IO module and install it. If this does not help, replace the CPU/IO module.
9010 - 9015	Can not boot from target Disk.	Check the target disk. In addition, replace it if required. If this does not help, replace the CPU/IO module.
9020	CPU is faulty.	Replace the CPU. If this does not help, replace the CPU/IO module.
9022 - 9023	Initialization of the cross-link between the CPU/IO modules and access are faulty.	When the system is running in the duplex mode, it is no problem. If the system cannot be running in the duplex mode due to continuous this error, replace the CPU/IO module. If this does not help, replace another CPU/IO module or center plane.
9024	Disconnect the cross-link between the CPU/IO modules.	When the system is running in the duplex mode, it is no problem. If the system cannot be running in the duplex mode due to continuous this error, replace the CPU/IO module. If this does not help, replace another CPU/IO module or center plane.

<b>On-screen error message</b>	<b>Cause</b>	<b>Action</b>
9027	Mounted CPU is mismatching.	CPU configuration may be different between the CPU/IO modules. Replace the CPU. If this does not help, replace the CPU/IO module.
9028	Memory of the different types is installed.	Memory of the different types is installed. Replace DIMM with appropriate one. If this does not help, replace the CPU/IO module.
9029	DIMM is faulty.	Replace DIMM. If this does not help, replace the CPU/IO module.
902A	Initialization of the cross-link between the CPU/IO modules and access are faulty.	When the system is running in the duplex mode, it is no problem. If the system cannot be running in the duplex mode due to continuous this error, replace the CPU/IO module. If this does not help, replace another CPU/IO module or center plane.
902B	BIOS revision does not match.	This BIOS revision cannot support the duplex mode. Update the BIOS revision.
9031	Configuration of PCI riser is mismatch.	Check the PCI configuration. If this does not help, replace the CPU/IO module.
9032	The microcode to CPU is not found and it cannot update normally.	Unsupported CPU may be mounted. Replace the CPU. If this does not help, replace the CPU/IO module.
9033	The microcode to CPU cannot update normally.	Replace the CPU. If this does not help, replace the CPU/IO module.
9034	DIMM is faulty.	Replace the DIMM. If this does not help, replace the CPU/IO module.
903A	DIMM is faulty.	Replace the DIMM. If this does not help, replace the CPU/IO module.
9040 - 9047	CPU is faulty. (ID=0-7)	Replace the CPU.
9050 - 9055	DIMM is faulty. (ID=0-5)	Replace the DIMM. If this does not help, replace the CPU/IO module.



On-screen error message	Cause	Action
9058 - 905F	This CPU/IO module detected the mismatch of CPUID between the CPU/IO modules.	CPU configuration may be different between the CPU/IO modules. Replace the CPU. If this does not help, replace the CPU/IO module.
9062 - 9063	CPU/IO module or ft Remote Management Card (option) is faulty.	If turning AC power off and on does not help, replace the CPU/IO module or ft Remote Management Card (option).
9065	One or both the CPU/IO modules have a problem.	There are some error messages in addition to this error code. Check the other error message.
9071 - 9072	Water-cooling kit has leaked out.	Replace the water-cooling kit. If this does not help, replace the CPU/IO module.
9080 - 908F 9080 - 9085 9087 - 908F	This CPU/IO module failed to get the information from another CPU/IO module.	When the system is running in the duplex mode, it is no problem. If the system cannot be running in the duplex mode due to continuous this error, replace the CPU/IO module. If this does not help, replace another CPU/IO module or center plane.
9086	The CPU/IO modules were unsuccessful to share information.	The GA driver may not support the server. Confirm that the driver is an appropriate one and restart the server. If this does not help, replace the CPU/IO module or center plane.
9026	The chip set revisions are mismatched.	The model of the CPU/IO modules mounted to the CPU modules is different. Replace the CPU/IO modules with those of the same model.

## Error Notification by BEEP

An error message may not be displayed on the display unit even though the POST detected an error. In such a case, the beep sounds notifies you an error. The error contents are indicated by the combination of beep sound patterns. For example, beep sounds once, consecutively three times, once, and then once (beep code: 1-3-1-1) indicates DRAM refresh test error.

The following table lists the meaning of beep codes and measures against them.

Beep code	Meaning	Action
1-2-2-3	ROM checksum error	Contact your sales agent to replace the CPU/IO module motherboard.
1-1-2-4	ROMEXEC code error	Check the installation of DIMM board.
1-3-1-1	DRAM refresh test error	If the error persists, contact your sales agent to replace the DIMM or CPU/IO module motherboard.
1-3-1-3	Keyboard controller error	Disconnect the keyboard and connect it back on. If the error persists, request your sales agent to replace the CPU/IO module motherboard.
1-3-3-1	Failed to detect memory. Or, DIMM board type is incorrect.	Check the installation of DIMM board. If the error persists, contact your sales agent to replace the DIMM or CPU module motherboard.
1-3-3-2	Initial setting error of the POST Memory Manager	
1-3-4-1	RAM address error	
1-3-4-3	RAM low byte data error	
1-4-1-1	RAM high byte data error	
2-2-3-1	Illegal interrupt test error	Contact your sales agent.
2-1-2-3	Copyright check error	
1-2	Failed to initialize the video BIOS	Check the connection of the connector for the display if nothing is displayed on the display unit.
	Failed to initialize the option ROM	If the error persists, contact your sales agent to replace the CPU/IO module motherboard.
	Failed to expand the option ROM	Check the PCI board installation if the option ROM of the added PCI board is not displayed. If the error persists, contact your sales agent to replace the CPU/IO module motherboard, PCI module board or added PCI board with new one.
1-5-1-1	FRB3 monitoring timeout	Check the installation of CPU. If the error persists, contact your sales agent.
1-5-2-2	CPU is not implemented	Check the installation of CPU. If the error persists, contact your sales agent.
1-5-2-3	CPU configuration error	Check the installation of CPU. If the error persists, contact your sales agent.
1-5-4-2	Power error	Check the installation of power. If the error persists, contact your sales agent.
1-5-4-4		

## Linux Error Messages

NEC Express5800/ft series displays messages on the console window when failures occur. Also, the same information is recorded as system logs.

The following indicates the syslog messages, messages on the console, their meanings and actions:

Message	Meaning	Action
The driver started successfully.	The driver was successfully started.	The server is operating normally.
The driver stopped.	The driver was successfully terminated.	
The driver failed to start.	The driver was not started successfully.	There may be problem in the system environment. Contact your sales agent.
The driver finished successfully to unload.	The unload processing of the driver finished successfully.	The server is operating normally.
The driver accepted to bind the CPU module.	The driver received an instruction to bind the CPU module.	
The driver started to bind the CPU module.	The driver started binding the CPU module.	
The driver finished successfully to bind the CPU module.	The driver successfully bound the CPU module.	
The driver failed to bind the CPU module.	The driver was unsuccessful to bind the CPU module.	If the message is recorded frequently, there may be problem in the hardware environment. Contact your sales agent.
The driver accepted to remove the CPU module.	The driver received an instruction to disconnect the CPU module.	The server is operating normally.
The driver started to remove the CPU module.	The driver started disconnecting the CPU module.	
The driver finished successfully to remove the CPU module.	The driver successfully disconnected the CPU module.	
The driver failed to remove the CPU module.	The driver was unsuccessful to remove the CPU module.	There may be problem in the hardware environment. Contact your sales agent.
The driver started the fast re-sync function of the CPU module.	The driver started performing fast re-sync to the CPU module.	The server is operating normally.
The driver finished successfully the fast re-sync function of the CPU module.	The driver successfully performed fast re-sync to the CPU module.	

Message	Meaning	Action
The driver failed the fast resync function of the CPU module.	The driver was unsuccessful to perform fast re-sync to the CPU module.	If the message is recorded frequently, there may be problem in the hardware environment. Contact your sales agent.
The driver accepted to change the priority of the CPU module.	The driver received an instruction to change the priority of the CPU module.	The server is operating normally.
The driver started to change the priority of the CPU module.	The driver started changing the priority of the CPU module.	
The driver finished to change the priority of the CPU module.	The driver successfully changed the priority of the CPU module.	
The driver failed to change the priority of the CPU module.	The driver was unsuccessful to change the priority of the CPU module.	There may be problem in the hardware environment. Contact your sales agent.
The driver accepted to bind the IO module.	The driver received an instruction to bind the IO module.	The server is operating normally.
The driver started to bind the IO module.	The driver started binding the IO module.	
The driver finished successfully to bind the IO module.	The driver successfully bound the IO module.	
The driver failed to bind the IO module.	The driver was unsuccessful to bind the IO module.	There may be problem in the hardware environment. Contact your sales agent.
The driver accepted to remove the IO module.	The driver received an instruction to disconnect the IO module.	The server is operating normally.
The driver started to remove the IO module.	The driver started disconnecting the IO module.	
The driver finished successfully to remove the IO module.	The driver successfully disconnected the IO module.	
The driver failed to remove the IO module.	The driver was unsuccessful to disconnect the IO module.	There may be problem of hardware environment. Contact your sales agent.
The driver accepted to switch Primary/Secondary state of the IO module.	The driver received an instruction to change the primary/secondary state of the IO module.	The server is operating normally.
The driver started to switch Primary/Secondary state of the IO module.	The driver started changing the primary/secondary state of the IO module.	
The driver finished successfully to switch Primary/Secondary state of the IO module.	The driver successfully changed the primary/secondary state of the IO module.	The server is operating normally.

<b>Message</b>	<b>Meaning</b>	<b>Action</b>
The driver failed to switch Primary/Secondary state of the IO module.	The driver was unsuccessful to change the primary/secondary state of the IO module.	There may be problem in the hardware environment. Contact your sales agent.
The driver started to bind the Module.	The driver started binding the CPU/IO module.	The server is operating normally.
The driver finished successfully to bind the Module.	The driver successfully bounded the module.	
The driver failed to bind the Module.	The driver was unsuccessful to bind the module.	There may be problem in the hardware environment. Contact your sales agent.
The driver accepted to remove the Module.	The driver received an instruction to disconnect the module.	The server is operating normally.
The driver started to remove the Module.	The driver started disconnecting the module.	
The driver finished successfully to remove the Module.	The driver successfully disconnected the module.	
The driver failed to remove the Module.	The driver was unsuccessful to disconnect the module.	There may be problem in the hardware environment. Contact your sales agent.
The driver accepted to update the BIOS.	The driver received an instruction to update BIOS.	The server is operating normally.
The driver started to update the BIOS.	The driver started updating BIOS.	
The driver finished successfully to update the BIOS.	The driver successfully updated BIOS.	
The driver failed to update the BIOS.	The driver was unsuccessful to update BIOS.	There may be problem in the hardware environment. Contact your sales agent.
The error occurred on the South Bridge.	There was a South Bridge error.	
FT nonfatal error occurred.	NEC GeminiEngine HA System Controller detected an error.	If the message is recorded frequently, there may be problem in the hardware environment. Contact your sales agent.
The error occurred on the CPU module.	There was a CPU module error.	
The error occurred on the PCI Express.	There was a PCI Express error.	There may be problem in the hardware environment. Contact your sales agent.
The driver detected that the Module was not working.	A module error was detected.	
DMA error occurred.	There was a DMA error.	There may be problem in the hardware environment. Contact your sales agent.
Legacy device error occurred.	There was a legacy device error.	
Surprise remove occurred.	Supprise removal occurred.	

<b>Message</b>	<b>Meaning</b>	<b>Action</b>
CRC error occurred on the FT Link.	There was a CRC error in FT Link.	There may be problem in the hardware environment. Contact your sales agent.
Accessing to shared memory with the BIOS failed.	Failed to access the memory shared with BIOS.	If the message is recorded frequently, there may be problem in the hardware environment. Contact your sales agent.
MTBF is below the threshold.	The MTBF of the module is lower than the threshold.	There may be problem in the hardware environment. Contact your sales agent.
There is a difference between the BIOS version.	The BIOS version of the module #0 and that of module #1 are different.	If the message is recorded frequently, there may be problem in the BIOS environment. Contact your sales agent.
Updating MTBF information failed.	Failed to update the MTBF information.	There may be problem in the system environment. Contact your sales agent.
IPMI driver does not start.	The IPMI driver is not running.	If the message is recorded frequently, there may be problem in the system environment. Contact your sales agent.
The driver failed to refer the object of IPMI driver.	Failed to refer to the IPMI driver object.	
Base address reading error. (NEC GeminiEngine HA System Controller I/O)	Base address reading error. (NEC GeminiEngine HA System Controller I/O)	There may be problem in the hardware environment. Contact your sales agent.
Base address reading error. (AMD8111 I/O)	Base address reading error. (AMD8111 I/O)	
The Modules does power down.	The module is powered off.	The server is operating normally.
Synchronization of the CPU module stopped.	Synchronization of the CPU module is stopped.	If the message is recorded frequently, there may be problem in the system environment. Contact your sales agent.
MC log was gathered.	MC log was collected.	The server is operating normally.
CMC log was gathered.	CMC log was collected.	
It failed in the collection of the MC/CMC log.	Failed to collect MC/CMC log of the module.	If the message is recorded frequently, contact your sales agent.
Memory check was completed successfully.	Memory check was completed successfully.	The server is operating normally.

<b>Message</b>	<b>Meaning</b>	<b>Action</b>
Memory check failed.	Memory check failed.	If the message is recorded frequently, there may be problem in the hardware environment. Contact your sales agent.
Memory copy was started.	Memory copy was started.	The server is operating normally.
The Module got power down in the middle of handling failure.	The module was powered off while troubleshooting an error.	
The Module or the CPU module detected the state change in the middle of handling failure of the CPU module so stopped the action.	The processing was stopped because a change in the CPU module state was detected while troubleshooting a CPU error.	If the message is recorded frequently, there may be problem in the hardware environment. Contact your sales agent.
The Module BIOS CPU state did not become [CPU stop (reset waiting)].	The CPU state of BIOS did not become [CPU stop (reset waiting)].	
The Module broke down.	The IO module failed.	There may be problem in the hardware environment. Contact your sales agent.
The serial number of the Module was invalid.	The serial number of the module is invalid.	If the message is recorded frequently, there may be problem in the system environment. Contact your sales agent.
Base address reading error. (PCI Config)	Base address reading error. (PCI Config)	There may be problem in the hardware environment. Contact your sales agent.
The system abnormality of the Module was detected.	Abnormality in the module was detected.	
The POST timeout occurred in the Module.	A POST timeout occurred in the module.	If the message is recorded frequently, there may be problem in the system environment. Contact your sales agent.
The POST error occurred in the Module.	A POST error occurred in the module.	
[Do not bind] is set by MTBF type.	The MTBF type of the module is set to [Do not bind].	There may be problem in the system environment. Contact your sales agent.
An illegal type is set to MTBF type.	The specified MTBF type of the module is invalid.	
The driver accepted to switch the Secondary Module.	The driver received an instruction to switch the secondary module.	The server is operating normally.
The driver started to switch the Secondary Module.	The driver started switching the secondary module.	
The driver finished successfully to switch the Secondary Module.	The driver successfully switched the secondary module.	

<b>Message</b>	<b>Meaning</b>	<b>Action</b>
The driver failed to switch the Secondary Module.	The driver was unsuccessful to switch the secondary module.	There may be problem in the hardware environment. Contact your sales agent.
The driver has already completed to bind the CPU module.	The CPU module has already been bound.	The server is operating normally.
The driver has already completed to remove the CPU module.	The CPU module has already been disconnected.	
The driver has already completed to change the priority of the CPU module.	The priority of the CPU module has already been changed.	
The driver has already completed to bind the IO module.	The IO module has already been bound.	
The driver has already completed to remove the IO module.	The IO module has already been disconnected.	
The driver has already completed to remove the Module.	The module has already been disconnected.	
The driver was not able to bind the Module. It has broken down in the past.	The module cannot be bound because it has failed in the past.	
The driver was not able to bind PCI Express 0. It has broken down in the past.	The PCI Express 0 cannot be bound because it has failed in the past.	
The driver was not able to bind PCI Express 1. It has broken down in the past.	The PCI Express 1 cannot be bound because it has failed in the past.	
The driver was not able to bind South Bridge. It has broken down in the past.	The South Bridge cannot be bound because it has failed in the past.	
The error occurred on the PXH.	There was an error in PXH.	
The error occurred on the device belong with the PXH.	There was an error in a device that belongs to PXH.	
Device is not duplexing.	The device is not duplexed.	Take necessary actions referring to "Troubleshooting" in the User's Guide.
The driver started to clear the MTBF.	The driver started clearing MTBF.	The server is operating normally.
The driver finished successfully to clear the MTBF.	The driver successfully cleared MTBF.	



Message	Meaning	Action
The driver started to set the MTBF threshold.	The driver started setting the MTBF threshold.	The server is operating normally.
The driver finished successfully to set the MTBF threshold.	The driver successfully set the MTBF threshold.	
The driver started to set the MTBF type.	The driver started setting the MTBF type.	
The driver finished successfully to set the MTBF type.	The driver successfully set the MTBF type.	
Board bootup error log detected in the Module.	An error log at the module startup was detected.	There may be problem in the system environment. Contact your sales agent.
[FT LED: Amber Blink] It is dumping it.	[FT LED: Amber Blink] Collecting dump.	The server is operating normally.
[FT LED: Amber On] MTBF of the CPU module is below the threshold.	[FT LED: Amber On] The MTBF of the CPU module is lower than the threshold.	If the message is recorded frequently, there may be problem in the system environment. Contact your sales agent.
[FT LED: Amber On] MTBF of the IO module is below the threshold.	[FT LED: Amber On] The MTBF of the IO module is lower than the threshold.	
[FT LED: Amber On] Module broke down.	[FT LED: Amber On] The module failed.	There may be problem in the system environment. Contact your sales agent.
[FT LED: Amber On] Not able to bind PCI Express 0. It has broken down in the past.	[FT LED: Amber On] The PCI Express 0 cannot be bound because it has failed in the past.	
[FT LED: Amber On] Not able to bind PCI Express 1. It has broken down in the past.	[FT LED: Amber On] The PCI express 1 cannot be bound because it has failed in the past.	
[FT LED: Amber On] Not able to bind South Bridge. It has broken down in the past.	[FT LED: Amber On] The South Bridge cannot be bound because it has failed in the past.	
[FT LED: Amber On] Not able to bind Module. It has broken down in the past.	[FT LED: Amber On] The module cannot be bound because it has failed in the past.	
[FT LED: Green On] The system was duplex.	[FT LED: Green On] The system was duplexed.	The server is operating normally.
[FT LED: Off] The driver did not bind the CPU module.	[FT LED: Off] The CPU module is not bound.	Take necessary actions referring to "Troubleshooting" in the User's Guide.
[FT LED: Off] The driver did not bind the IO module.	[FT LED: Off] The IO module is not bound.	
[FT LED: Off] The Network device is not duplex.	[FT LED: Off] The network device is not duplexed.	
[FT LED: Off] The SCSI device is not duplex.	[FT LED: Off] The SCSI device is not duplexed.	

Message	Meaning	Action
[FT LED: Off] The FC device is not duplex.	[FT LED: Off] The FC device is not duplexed.	Take necessary actions referring to "Troubleshooting" in the User's Guide.
Since removal of each device was not completed, the driver was not able to bind the CPU/IO module.	The CPU/IO module cannot be bound because devices have not been completely removed yet.	
HAS driver enabled use of USB.	The USB queue timed out.	
[FT LED: Off] South Bridge is not doubled.	[FT LED: Off] The South Bridge is not duplexed.	
[FT LED: Off] PCI Express 0 is not doubled.	[FT LED: Off] The PCI Express 0 is not duplexed.	
[FT LED: Off] PCI Express 1 is not doubled.	[FT LED: Off] The PCI Express 1 is not duplexed.	
[FT LED: Off] CPU is not doubled.	[FT LED: Off] The CPU is not duplexed.	
Removal of SCSI device was not completed.	The removal processing of the SCSI device has not been completed.	
[FT LED: Off] The doubleness information about an I/O device is not reported.	[FT LED: Off] The duplexity information on the I/O device has not been reported.	The server is operating normally.
Service is stopped by the notice of a stop.	The HAS management service is stopped by an instruction from the OS.	
Snapshot dump is started.	The dump service of the system running in the duplex mode is started.	
Stop image dump is started.	The dump service of the system running in the simplex mode is started.	
Quick dump is started.	The quick dump service is started.	If the error occurs frequently, contact your sales agent.
It failed in the doubleness surveillance of a network card.	Failed to monitor duplexity of the network card.	
It failed in the doubleness surveillance of a SCSI device.	Failed to monitor duplexity of the SCSI device.	If the error occurs frequently, contact your sales agent.
It failed in the doubleness surveillance of a FC device.	Failed to monitor duplexity of the FC device.	
The error occurred in session creation with client application.	Failed to create a session for communication with client applications.	Contact your sales agent.

Message	Meaning	Action
It failed in the client attestation.	Client authentication was unsuccessful.	Contact your sales agent.
It failed in the initialization of a transaction.	Failed to initialize the transaction.	
Transaction task abort.	The transaction is terminated because there was a communication error.	
Invalid service demand.	An invalid service was requested.	
It failed in the device I/O control from client application.	The I/O control requested by the client was unsuccessful.	
It failed in the notification of doubling information for the HAS Driver.	Failed to report the duplexed status to the HAS driver.	
It failed in IOCTL which notifies the removal completion of USB device to a driver.	Failed to report the completion of the USB removal to the HAS driver.	
It failed in the start of snapshot dump.	There was an error when starting the active dump service.	
It failed in the start of stop image dump.	There was an error when starting the stopped dump service.	
It failed in the start of quick dump.	There was an error when starting the quick dump service.	
It failed in the setting of the FC watch library.	Failed to read and set FC duplexity monitoring library.	Restart the system. If the error occurs frequently, contact your sales agent.
It failed in the setting of the SCSI watch library.	Failed to read and set SCSI duplexity monitoring library.	
It failed in the setting of the NIC watch library.	Failed to read and set network duplexity monitoring library.	
If failed in the initialization of a device doubleness surveillance event.	Failed to initialize the duplexity monitoring event.	
It failed in the initialization of a timer.	Failed to initialize and set the timer for monitoring duplexity.	
If failed in the daemon start.	Failed to start the HAS monitoring service.	

## Server Management Application Error Message

If the server management tool such as NEC ESMPRO Agent or NEC ESMPRO Manager has been installed in the NEC Express5800/ft series or management PC, you can obtain the error information from the display unit of the server or management PC.

See Chapter 5 or online documentation for details of such application programs.

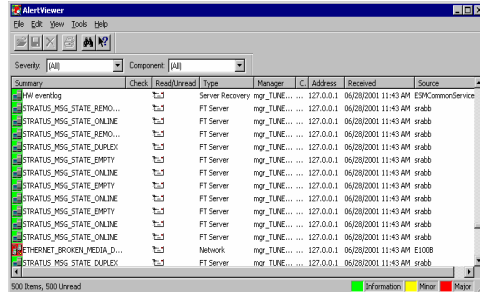

---

## SOLVING PROBLEMS

When the server fails to operate as expected, see the following to find out your problem and follow the given instruction before asking for repair.

If the server still fails to operate successfully after solving your problem, take a note on the on-screen message and contact your sales agent.

---

### Problems with NEC Express5800/ft series

#### Fail to power on the server:

- Is the server properly supplied with power?
  - Check if the power cord is connected to a power outlet (or UPS) that meets the power specifications for the server.
  - Check if the two pieces of the provided power cord are connected to the main unit properly.
  - Make sure to use the power cord provided with the server. Check the power cord for broken shield or bent plugs.
  - Make sure the power breaker for the connected power outlet is on.
  - If the power cord is plugged to a UPS, make sure the UPS is powered and it supplies power. See the manual that comes with the UPS for details.  
  
Power supply to the server may be linked with the connected UPS using the BIOS setup utility of the server.  
  
<Menu to check: [Server] - [AC-LINK] - [Power On]>
  - Make sure the POWER switch on the power unit is on.
- Did you press the POWER switch?
  - Press the POWER switch on the front of the NEC Express5800/ft series to turn on the power (the POWER LED lights).
- Did you install the CPU/IO module properly?
  - Check if the CPU/IO module is properly installed in the server. Secure the CPU/IO module with screw located on the module removable handle. The server cannot be powered on unless it is screwed completely.
- Is the FAULT LES of the CPU/IO module on?
  - Remove and reinsert the CPU/IO module and restart the server.

**Fail to power off the server:**

- Is the POWER switch enabled?
  - Restart the server and start the BIOS setup utility.
    - <Menu to check: [Security] → [Switch Inhibit] → [Enabled]>
- Are you trying to power off by a method other than pressing the POWER switch?
  - You cannot power off the server by using software commands such as the shutdown command. Press the POWER switch to power off the server.

**POST fails to complete:**

- Is the DIMM installed?
  - At least one DIMM is required for operation.
- Is the memory size large?
  - The memory check may take a time if the memory size is large. Wait for a while.
- Did you perform any keyboard or mouse operation immediately after you started the server?
  - If you perform any keyboard or mouse operation immediately after start-up, POST may accidentally detect a keyboard controller error and stops proceeding. In such a case, restart the server once again. Do not perform any keyboard or mouse operation until the BIOS start-up message appears when you restart the server.
- Does the server have appropriate memory boards or PCI card?
  - Operation of the server with unauthorized devices is not guaranteed.

**Server reboots while running the SCSISelect utility:**

- Have you modified the Setup settings?
  - From [Server] - [Monitoring Configuration] - [Option ROM Scan Monitoring] of Setup, select "Disabled." If [Option ROM Scan Monitoring] is enabled, the system may reboot while using the SCSISelect utility. Change back the setting after you finish using the utility.

**Fail to access to internal or external devices:**

- Are cables properly connected?
  - Make sure that the interface cables and power cord are properly connected. Also make sure that the cables are connected in the correct order.
- Is that device compliant with NEC Express5800/ft series?
  - Operation of the server with unauthorized devices is not guaranteed.

- ❑ Is the power-on order correct?
  - When the server has any external devices connected, power on the external devices first, then the server.
- ❑ Did you install drivers for connected optional devices?
  - Some optional devices require specific device drivers. Refer to the manual that comes with the device to install its driver.
- ❑ Is SCSI controller (including options) configuration correct?
  - If the sever has an optional SCSI controller board and SCSI devices are hooked up to the server, make correct settings by the SCSI controller board's SCSI BIOS utility. For details, see manuals included with the SCSI controller board.
- ❑ Is SCSI device configuration correct?
  - If external SCSI devices are connected to the server, you need to make settings of SCSI ID and terminal resistance. For details, see manuals included with the SCSI device.
- ❑ Does the SCSI driver recognize the target devices?
  - Execute the following command to check if the SCSI driver recognizes the target devices.
 

```
>cat /proc/scsi/scsi
```
- ❑ Is a driver which supports the SCSI device loaded to kernel?
  - Execute the following command to check if a driver which supports the SCSI device is loaded to kernel.
 

```
>lsmmod
```

**CPUs not in Duplex mode:**

- Check if the memory configuration is correct.
- Check if third-party CPUs or memory (DIMM) are used.

**BIOSes not in Duplex mode due to differences between both modules:**

- Check if the setting of [Automatic firmware update] is disabled on the [System Setting] screen on the main window of [Server Maintenance Utility].
- If the setting of [Automatic firmware update] is enabled and modules are remounted, BIOSes are automatically updated and duplicated. At this time, it is recommended to reduce the load of the system as much as possible.

**Disks not in Duplex mode:**

- Unless you perform mirroring (including reconfiguration after failed disks are replaced) in correct order, the mirror may not be (re)configured. Check if the steps were correct.

**The keyboard or mouse fails to operate:**

- Is the cable properly connected?
  - Make sure that the cable is connected to the correct connector on the rear of the server.
- Are the keyboard and mouse are compliant with NEC Express5800/ft series?
  - Operation of the server with unauthorized devices is not guaranteed.
- Does the server have drivers installed?
  - Refer to the manual that comes with your OS to check that the keyboard and mouse drivers are installed. (These drivers are installed along with the OS.) Some OS's allow you to change the keyboard and mouse settings. Refer to manual that comes with your OS to check that the keyboard and mouse settings are correct.

**Screen freezes, keyboard and mouse do not work:**

- If the amount of memory is large, it takes time to copy the memory in dual mode and the system stops working temporarily during the copying, but it is not system trouble.

**Fail to access (read or write) to the floppy disk:**

- Does the floppy disk drive contain a floppy disk?
  - Insert a floppy disk into the floppy disk drive until it clicks.
- Is the floppy disk write-protected?
  - Place the write-protect switch on the floppy disk to the "Write-enabled" position.
- Is the floppy disk formatted?
  - Use a formatted floppy disk or format the floppy disk in the floppy disk drive. Refer to the manual that comes with the OS for formatting a floppy disk.
- Is the media mounted?
  - If a failover occurs while the media is mounted, the media is forcibly unmounted. Therefore you need to mount it again. (When mounting CPU/IO module and at a failover, errors such as buffer I/O error may be recorded, but there is no problem on operation they are specifications of the server.) After the failover, device name of the floppy disk drive may be changed (Ex. from scd0 to scd1), that phenomenon is due to the specifications of the server and does not affect the operation. In such a case, specify the changed device name for mounting the media.

**Mount point is not automatically created:**

- If mount point is not automatically created, the service needs to be restarted. Run the following commands as root user to start the service.

```
# /etc/init.d/messagebus restart
# /etc/init.d/haldaemon restart
```



**Fail to access to the CD-ROM:**

- Is the CD-ROM properly set in the CD-ROM drive tray?
  - The tray is provided with a holder to secure the CD-ROM. Make sure that the CD-ROM is placed properly in the holder.
- Is the CD-ROM applicable to the server?
  - The CD-ROM for Macintosh is not available for use.
- Is the media mounted?
  - If a failover occurs while the media is mounted, the media is forcibly unmounted. Therefore you need to mount it again. (When mounting CPU/IO module and at a failover, errors such as buffer I/O error may be recorded, but there is no problem on operation as they are specifications of the server.) After the failover, device name of the CD-ROM drive may be changed (Ex. from scd0 to scd1), that phenomenon is due to the specifications of the server and does not affect the operation. In such a case, specify the changed device name for mounting the media.

**Fail to access the hard disk:**

- Is the hard disk applicable to the server?
  - Operation of any device that is not authorized by NEC is not guaranteed.
- Is the hard disk properly installed?
  - Make sure to lock the hard disk with the lever on its handle. The hard disk is not connected to the internal connector when it is not completely installed (see Chapter 8). When the hard disk is properly installed, the drive power LED for the hard disk is lit while the server is powered.

**Fail to start the OS:**

- Is a floppy disk in the floppy disk drive?
  - Take out the floppy disk and restart the server.
- Is the NEC EXPRESSBUILDER CD-ROM (or the other bootable CD-ROM) in the CD-ROM drive?
  - Take out the CD-ROM and restart the server.
- Is the OS damaged?
  - Use the recovery process of the OS to attempt to recover the damaged OS.
- Is reset performed by the boot monitoring function?
  - For the following cases, boot monitoring function needs to be disabled for NEC Express5800/ft series. To disable it, see “Step 3: Disable the Startup Monitoring Function Setting.”
    - To enter into the kudzu setup mode and make settings while the OS is starting.
    - To change the boot mode to the interactive startup mode.

Note: You can change the interactive startup mode by entering the message “I” when “Press ‘I’ to enter interactive startup.” appears during the OS startup.

- When the system enters into the maintenance mode while the OS is starting.

Note: The following message is displayed on the screen:  
Give root password for maintenance  
(or type Control-D to continue):

- For other cases that daemons and/or drivers are not started successfully due to errors or other causes.

Note: For configuration that the actual memory capacity and the disk capacity are large, it is recommended to change the BIOS Setup from the default (10 minutes) to an appropriate value.

**It takes time to display the screen on the OS when 2.5GB or more memory is mounted:**

- Check the Cache Settings of the BIOS settings. In the Processor Settings on the Main screen, change the Cache Settings to “Discrete.” This setting optimizes the visual display.

**OS behavior is unstable:**

- Have you modified kernel?
  - Confirm that no patch for general kernel is applied or that the kernel that has been installed for NEC Express5800/ft series is not modified.

**IO module is not disconnected:**

- When you attempt to disconnect IO module while network adapter and/or SCSI adapter and/or FC adapter is not in dual mode, the following message will be recorded to the system event log and the IO module will not be separated. In this case, check each adapter setting referring to “After starting up, FT Status LED do not illuminate or illuminate amber” of this chapter.

Source: HasCtrl  
Type: Warning  
Event ID: 1505  
Description: Device [Device name] is not duplexing.  
[Device name] “LAN” or “SCSI” or “FC”

- When you attempt to disconnect IO module when the HAS Fault Tolerance service is not started, the following message will be recorded to the system event log and the IO module will not be separated. In this case, refer to “After starting up, FT Status LED do not illuminate or illuminate amber” of this chapter to start the HAS Fault Tolerance service and retry disconnecting the I/O module.

Source: HasCtrl  
 Type: Warning  
 Event ID: 1506  
 Description: The doubleness information about an I/O device is not reported.

**Video mode cannot be changed by using the Xrandr feature of XServer:**

→ Specification of the server. For setting the video mode, see “SETTING THE VIDEO MODE” on page 3-10.

**Settings such as screen size and color are made from Control Panel, but they are not enabled:**

→ Specification of the server. Even if you change the video mode on the [DisplaySetting] tab displayed by selecting the Start menu, [System], [Control Panel], and then [Display] or by right-clicking the blank space of the desktop and selecting [Video Property], the change is not reflected to the system. For setting the video mode, see “SETTING THE VIDEO MODE” on page 3-10.

**DISK ACCESS LED is amber and blinking:**

Is the mirror of the hard disk not removed?

→ Check [Disk Management], and reconfigure the mirror if the mirror is broken.

(See “HARD DISK CONFIGURATIONS THAT CAN BE BUILT ON THE NEC Express5800/ft series” in Chapter 3 “Linux Setup and Operation.”)

Relevant Disk LED and DISK ACCESS LED illuminate amber during the process of automatic mirror reconfiguration. During the process of reconfiguration, DISK ACCESS occurs at the same time, and amber and green appear to illuminate alternately. Wait for a while if it is found out that the mirror is being reconfigured in “Disk Management,” etc.

When one of the disks that configure the mirror is broken, the other disk becomes “Failed Redundancy.” In this case, DISK LED also illuminates amber. Replace the failed disk and reconfigure the mirror.

**The setting screen for kudzu is displayed at each startup:**

→ When the system is started from a module different from the previous startup, the setting screen for kudzu is displayed. However, no operation is required.

**The screen of X is not displayed after failover:**

→ This phenomenon may occur when you start X by running startx on the text console. For using X, read the notes on page 3-11.

**When incorporating the module again it has been disconnected, the network is not duplexed:**

- Has the module been completely disconnected?
  - When you disconnected the module using NEC ESMPRO and tried to incorporate it again, the network may not be duplexed if the module is not completely disconnected. Make sure that the module is completely disconnected by confirming that the FT-LED is turned off and the module is powered off, and then incorporate the module.
  - If incorporating the module does not start for a few minutes, try to incorporate it again.

**When turning on the DC power after the module has been implemented, “\$ESMALERT:HAS:C00706A6\$ The driver failed to bind the Module.” is notified:**

- After the module is implemented, if the timing to turn on the DC power is too early, this message may be displayed.
  - Right after implementing the module, hardware is initialized. When the DC power is turned on before the initialization process completes, this message may be displayed, but there is not any problem. After that, if the DC power of the module is not automatically turned on, press the DC button again to turn on the DC power.

**The network is not duplexed:**

- If the network is not duplexed, redundancy of the system is incomplete, and the status LED indicator does not illuminate green. Follow the steps below to check the network configuration:

[Procedure]

1. Run “ifconfig -a |grep eth.”

If no message appears, the network is successfully duplexed.

If the standard device names for Linux (such as eth0, eth1) are assigned to Ether devices, the network is not duplexed.

```
-----
# ifconfig -a |grep eth
eth0      Link encap:Ethernet  HWaddr 00:XX:XX:XX:XX:XX
eth1      Link encap:Ethernet  HWaddr 00:YY:YY:YY:YY:YY
-----
```

2. Run “udevstart.”

All the Linux standard device names will be renamed to the ones for your NEC Express5800/ft series (such as e08030, e13030), and the network is duplexed.

3. Run “ifconfig -a |grep eth” again to confirm that no message appears.

## Event Log

### HAS Daemon-related logs are recorded in the system event log.

- When you manage servers using NEC ESMPro Manager, the following message may be recorded in the system event log. This message does not indicate an event that impacts operations. However, if it is recorded frequently, there may be problem in OS or the software environment. Contact your sales agent.

```
Source:    HAS Daemon
Type:     Warning
Event ID: 800000cc – 800000d2
```

- The following message may be recorded in the system event log for operation or replacement maintenance of each network adapter, SCSI disk or fibre channel. This message does not indicate an event that impacts operations. However, if it is recorded frequently or even when maintenance procedures are followed, there may be problem in OS or the software environment. Contact your sales agent.

```
Source:    HAS Daemon
Type:     Warning
Event ID: 800000cc – 800000d2
```

### hasftctl-related logs are recorded in the system event log.

- The following message may be recorded in the system event log. This log does not indicate an event that impacts operations. This message informs that the CPU modules are no longer in the duplex mode. However, dual configuration is to be set to the CPU modules again, so this warning does not indicate any impact on the system operation.

```
Source:    hasftctl
Type:     Warning
Event ID: 800704B2
Description: The driver failed the fast re-sync function of the CPU module.
```

```
Source:    hasftctl
Type:     Warning
Event ID: 80070DAC
Description: The error occurred on the CPU module.
```

```
Source:    hasftctl
Type:     Warning
Event ID: 80070fa0
Description: The error occurred on the CPU module.
```

```
Source:    hasftctl
Type:     Warning
Event ID: 40071209
Description: CPU is not doubled.
```

## **Syslog**

### **“I/O error” is recorded in the log at OS startup:**

- The following message may be displayed on the screen or recorded in the log if a USB floppy disk drive is connected at OS startup. However, this will not impact operations (in the description below, \* represents an alphanumeric character).

Partition Check:

```
sdg:<6> I/O error: dev **:**, Command *****, sector 0  
I/O error : dev **:**, Command *****, sector 0  
unable to read partition table
```

### **“APIC error” is recorded in the syslog by the operations such as inserting/removing disks:**

- A message “APIC error” may be recorded to the log or displayed on the screen when you perform operations such as inserting/removing disks with the server powered on, because the internal status managed by the OS and the actual status on the server side are different. The operations are not affected.

### **“info synchronization error” is recorded while the CPU modules are being synchronized:**

- A message “info synchronization error” may be recorded in the log when the CPU modules are performing duplication because the internal status managed by the OS and the actual status on the server side are different. The operations are not affected.

### **“card reports no resources” log is recorded when using the built-in LAN board:**

- A message “card reports no resources” may be output to the log when the system cannot allocate the resource for the LAN driver due to high load ratio on the network access. The operations are not affected. LAN driver performs retry automatically thus the system continues communication without disconnecting the network connection.

**“I/O error” is recorded in the syslog by the cable disconnection during the access to the Fibre Channel disk:**

- When the Fibre Channel connected to the primary PCI module Cable is disconnected during the access to the Fibre Channel disk, logs may be recorded, which seem that “SCSI disk (/dev/sdd\*\*)I/O error”(\*\*) represent numbers) occurred on the devices which are not running because the internal status managed by the OS and the actual status on the server side are different. The operations are not affected.

**HASIPMI-related logs are recorded in the log:**

- The following event logs may be recorded during the system operation. These logs are recorded when the software that access to BMC could not receive response from BMC within a given period of time. There is no problem to the system by this warning.

A timeout occurred for waiting BMC response. Process = (Although Primary BMC is ready)

A timeout occurred for waiting BMC response. Process = (Secondary BMC is still running)

**SCSI-related logs are recorded in the system event log:**

- SCSI driver records mounting and unmounting of a module in the system event log, but these events do not affect the system. However, if they are recorded for over 5 minutes, contact your sales agent.

<When mounting a module > (“\*” is different for each system.)

scsi0: Someone reset channel A

[aic79xx/scsi\*] occur Hardware error interrupt.

scsi\*: hwerrint, Discard Timer has timed out

scsi\*: Recovery Initiated - Card was paused

scsi\*: Recovery Initiated - Card was not pausedA timeout occurred for waiting

<When unmounting a module > (“\*” is different for each system.)

scsi\*: Recovery Initiated - Card was paused

scsi\*: Recovery Initiated - Card was not paused

scsi\*: Recovery Initiated - Card was paused, not connected.

scsi\*: Recovery Initiated - Card was not paused, not connected.

(scsi\*:A:0:0): SCB 0x0 - timed out

(scsi\*:A:0:0): Other SCB Timeout

(scsi\*:A:0:0): No other SCB worth waiting for...

[aic79xx/scsi\*] HBA seems to be removed.

```
[aic79xx/scsi*] start to remove the HBA.  
[aic79xx/scsi*] unregister SCSI host on kernel.  
[aic79xx/scsi*] SCSI host was unregistered.  
[aic79xx/scsi*] HBA was removed.  
[aic79xx/scsi*] ahd_stat_timer: HBA was lost.  
[aic79xx/scsi*] Reject the request. adapter was already removed.  
[aic79xx/scsi*] Reject the request. adapter lost(not notified to remove yet).
```

**FC-related logs are recorded to the system event log:**

- FC driver records mounting and unmounting of a module in the system event log, but these events do not affect the system. However, if they are recorded for over 5 minutes, contact your sales agent.

<When mounting a module> (“n” and “x” are different for each system.)

```
lpfc nnnn:nn:nn.n: n:1303 Link Up Event x1 received Data: xx xx xx xx
```

<When unmounting a module > (“\*” is different for each system.)

```
lpfc nnnn:nn:nn.n: n:0203 Nodev timeout on NPort xxx Data: xxxxx xx xx
```

```
lpfc nnnn:nn:nn.n: n:0253 Illegal State Transition: node xe8 event xx, state xx  
Data: xx xxxxx
```

```
lpfc nnnn:nn:nn.n: n:0263 Cannot block scsi target. target ptr xxxxxxxxx
```

```
lpfc nnnn:nn:nn.n: dma_pool_destroy lpfc_mbuf_pool, xxxxxxxx busy
```



## Problems with NEC EXPRESSBUILDER

When the server is not booted from the NEC EXPRESSBUILDER CD-ROM, check the following:

- Did you set the NEC EXPRESSBUILDER CD-ROM during POST and restart the server?
  - If you do not set the NEC EXPRESSBUILDER CD-ROM during POST and restart the server, an error message will appear or the OS will boot.
- Is BIOS configuration correct?
  - The boot device order may be specified with the BIOS setup utility of the server. Use the BIOS setup utility to change the boot device order to boot the system from the CD-ROM drive first.  
<Menu to check: [Boot]>

When an error occurs while the NEC EXPRESSBUILDER is in progress, the following message appears. After this message appears, check the error and take the appropriate corrective action according to the error codes listed in the table below.

Message	Cause and Remedy
This machine is not supported.	This NEC EXPRESSBUILDER version is not designed for this server. Execute the NEC EXPRESSBUILDER on the compliant server.
NvRAM access error	An access to the nonvolatile memory (NvRAM) is not acceptable.
Hard disk access error	The hard disk is not connected or it is failed. Check whether the hard disk is correctly connected.
There is no device specific information on motherboard. Restore the backup information or write the information using [System Information Management] in offline maintenance utility. Only maintenance personnel can operate this. Are you going to run offline maintenance utility?	This message is displayed when NEC EXPRESSBUILDER cannot find device specific information, such as when replacing a motherboard. Maintenance personnel write information using offline maintenance utility.

---

## **Problems with NEC ESMPRO**

NEC ESMPRO Agent

→ See Chapter 5.

NEC ESMPRO Manager

→ See Chapter 5. See also online document in NEC EXPRESSBUILDER CD-ROM for troubleshooting and other supplementary information.

## COLLECTION OF TROUBLE LOGS

In the event of trouble, you can get information in the procedures described below:

---

**IMPORTANT:**

- You can perform the procedures described below only when you are asked by your maintenance personnel to get trouble logs.
  - When the system restarts after the trouble, it may show a message that there is a shortage of virtual memory. However, continue the system startup. If you reset and restart the system, you cannot get correct information.
- 

---

### Collection of syslog

The log file of Linux is created under the following directory in text format:

`/var/log/`

The log file of NEC Express5800/ft series is also created in this directory, as with general log file of Linux.

---

### Collection of System Information

The system information of Linux is recorded in syslog, etc.

---

## Collection of the Memory Dump

If a failure occurs, the memory data should be dumped to acquire the required information.

---

### IMPORTANT:

- Consult with your sales agent before dumping the memory. Executing memory dumping while the server is in the normal operation may affect the system operation.
  - Restarting the system due to an error may display a message indicating insufficient virtual memory. Ignore this message and proceed. Restarting the system again may result in dumping improper data.
- 

## Preparing for Memory Dump

Memory dumping with the DUMP switch may disable the server to restart. In such a case, it is required to force the server to shut down. This forced shutdown, however, is not available if "Enabled" is selected for "Switch Inhibit" on the "Security" menu of the BIOS Setup Utility "SETUP," because this setting disables POWER switch operation.

Follow the procedure below to change the setting to enable the forced shutdown and reset the server.

1. Power on the server and start the BIOS Setup Utility "SETUP."
2. Select "Disabled" for "Switch Inhibit" in the "Security" menu.
3. Save the configuration data and exit the SETUP.

## Saving Dump Files

Press the DUMP switch to save the dump file when an error occurs. Insert a metal pin (a straightened large paper clip will make a substitute) into the switch hole to press the switch.

Pressing the switch saves the dump file in the specified directory. (Memory dumping may not be available when the CPU stalls.)

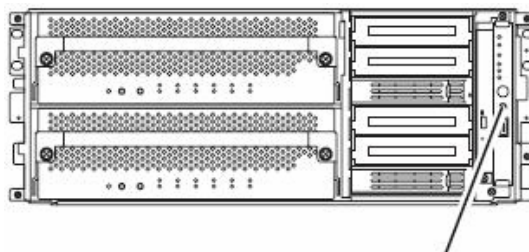

Dump switches

---

### IMPORTANT:

Do not use a toothpick or plastic stick that is easy to break.

---

When the DUMP switch is pressed, the system restarts and collects the memory dump.

## Time Required for Dump Collection

### - QuickDump

1. From pressing the NMI switch until the server is started: about 5 minutes

Note: It may take longer depending on the system configuration.

2. From the server startup until the completion of a dump file creation: 10 minutes/1GB of memory

Note: The time required for completion may vary depending on the system configuration and load.

QuickDump runs on the background, and does not affect the operation.

### - diskdump

1. From pressing the NMI switch until the completion of collecting dump and the server startup: About 10 minutes

Note: It may take longer depending on the mounted memory size (when 12GB memory is mounted, it takes about 30 minutes).

## Storing Dump File

### - Quick Dump

When there is not enough space for storing the dump file, Quick Dump deletes other dump files and stores the new one.

Note: Save necessary dump files to other storage device in order to avoid the files to be deleted before the storage run out of space.

### - diskdump

When there is not enough space for storing the dump file, dump is not collected.

Note: Store necessary dump files on other storage device and make sure there is enough space to store a new dump file.

## Notes on Collecting diskdump

- The HDD access LED illuminates during dump collection.

- The screen may remain blank even if dump is being collected. Do not perform forced DC off.

## BACKUP OF IPMI INFORMATION

Collect the IPMI information. NEC ESMPRO Agent must be installed to collect the information.

1. Log on to the system as a user with a root authority.
2. Move to the directory where the NEC ESMPRO Agent is installed.  
`cd /opt/nec/esmpro_sa`

3. Move to the directory where ESRAS Utility is stored.

4. Execute the following command:

```
./xrasutil
```

ESRAS Utility will start.

5. Select <Backup the current IPMI Information...>.

The IPMI Information Backup screen will appear.

6. Enter an output destination and a comment, and then select [OK].

The information will be output to the specified location.

<Backup File Name>: Specify the path to the file on which you want to save the information. By default, the information is output to log/ipmi.dat which is under the directory where NEC ESMPRO Agent is installed.

<Comment>: Describe the information which you want to output with. (Optional)

For using the Server Maintenance Utility in Japanese, run the command below before starting it. This command starts X Window and the screen will be displayed in the Japanese fonts.

```
init 5
```

If you start the Server Maintenance Utility without starting the X Window, messages displayed on the console may affect the screen display. If the screen is not displayed properly, press **Ctrl + L** to refresh the screen.

# Chapter 8

---

## System Upgrade

This chapter describes procedures to add options and replace failed components.



---



**IMPORTANT:**

- Optional devices described in this chapter may be installed or removed by the user. However, NEC does not assume any liability for damage to optional devices or the server or malfunctions of the server resulted from installation by the user. NEC recommends you ask your sales agent to install or remove any optional devices.
  - Be sure to use only optional devices and cables designated by NEC. Repair of the server due to malfunctions, failures, or damage resulted from installing such devices or cables will be charged.
-

## SAFETY PRECAUTIONS

Observe the following notes to install or remove optional devices safely and properly.

 <b>WARNING</b>	
	<p>Observe the following instructions to use the server safely. There are risks of death or serious personal injury. See “PRECAUTIONS FOR SAFETY” in Chapter 1 for details.</p> <p>Do not disassemble, repair, or alter the server. Do not look into the CD-ROM drive. Do not remove the lithium battery. Disconnect the power plug before working with the server.</p>

 <b>CAUTION</b>	
	<p>Observe the following instructions to use the server safely. There are risks of fire, personal injury, or property damage. See “PRECAUTIONS FOR SAFETY” in Chapter 1 for details.</p> <p>Do not install or remove components by a single person. Do not install the server leaving the cover removed. Make sure to complete component installation. Do not pinch your finger(s). High temperature</p>



## ANTI-STATIC MEASURES

The server contains electronic components sensitive to static electricity. Avoid failures caused by static electricity when installing or removing any optional devices.

- Wear wrist straps (arm belts or anti-static gloves).

Wear wrist straps on your wrists. If no wrist strap is available, touch an unpainted metal part of the cabinet before touching a component to discharge static electricity from your body.

Touch the metal part regularly when working with components to discharge static electricity.

- Select a suitable workspace.
  - Work with the server on the anti-static or concrete floor.
  - When you work with the server on a carpet where static electricity is likely to be generated, make sure take anti-static measures beforehand.
- Use a worktable.

Place the server on an anti-static mat to work with it.
- Clothes
  - Do not wear a wool or synthetic cloth to work with the server.
  - Wear anti-static shoes to work with the server.
  - Take off any metal accessories you wear (ring, bracelet, or wristwatch) before working with the server.
- Handling of components
  - Keep any component in an anti-static bag until you actually install it to the server.
  - Hold a component by its edge to avoid touching any terminals or parts.
  - To store or carry any component, place it in an anti-static bag.

## PREPARING YOUR SYSTEM FOR UPGRADE

Note the following, when installing or replacing devices, to improve the performance of NEC Express5800/ft series.

- With the NEC Express5800/ft series, devices can be replaced during the continuous operation. Take extreme care for electric shock and damage to the component due to short-circuit.
- Optional devices cannot be installed or removed during continuous operation. Normally, shutdown the OS, check that the server is powered off, disconnect all power cords and interface cables from the server before installing or removing the optional devices.
- To remove the CPU or PCI module during the continuous operation, disable the intended module (place the module off-line) by using the Server Maintenance Utility of the NEC ESMPRO Agent or the NEC ESMPRO Manager from the management PC on the network. After a new module is installed to the server, enable the module using the Server Maintenance Utility or the NEC ESMPRO Manager.

---

### **TIPS:**

The system is defaulted to automatically boot the module, once installed. For more information, see Chapter 5.

---

- Make sure to provide the same hardware configuration on both groups.
- Use the same slots and sockets on both groups.
- Do not install those devices having different specifications, performance, or features.
- Before removing the setscrews from the CPU/IO modules, place the desired module off-line using the Server Maintenance Utility or the NEC ESMPRO Manager.

## 3.5-INCH HARD DISK DRIVE

The 3.5-inch hard disk drive bay in front of the server contains six slots in which hard disks with the SCA2 interface are installed.

---

### IMPORTANT:

- Do not use any hard disks that are not authorized by NEC. Installing a third-party hard disk may cause a failure of the server as well as the hard disk. Purchase hard disks of the same model in pair. Contact your sales agent for hard disk drives optimum for your server.
- 

### TIPS:

- The primary CPU/IO module is determined by the order of connecting power cords (see Chapter3).
- 

The 320Fb-L model is used in the example quoted here. However, steps you should take are the same for other models. You can install 25.4mm (1-inch) high hard disk drives to six 3.5-inch hard disk drive bays on the server. 3.5-inch hard disk drive bays have labels with slot number.

The hard disk drives installed on the slot 0, 1 and 2 are mirrored with the slot 3, 4, and 5 respectively. (The OS is installed on the mirror volumes that consist of the hard disks in the slot 0 and 3)

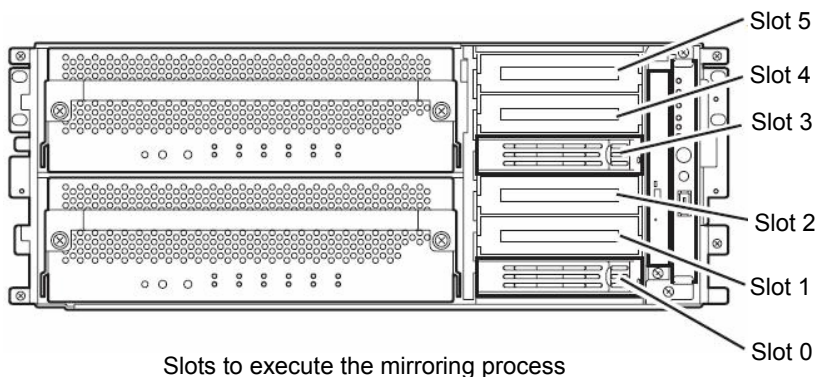

Empty slots in the 3.5-inch hard disk drive bay contain dummy trays. The dummy trays are inserted to improve the cooling effect within the device. Always insert the dummy trays in the slots in which hard disks are not installed.

Attach an HDD ID label indicating the slot number of installed hard disk to the handle of the hard disk.

---

## Installing 3.5-inch Hard Disk Drive

Follow the procedure below to install the hard disk. A hard disk may be installed in another slot in the same procedure.

---

### IMPORTANT:

Make sure to read "ANTI-STATIC MEASURES" and "PREPARING YOUR SYSTEM FOR UPGRADE" before starting installing or removing options.

---

1. Click [Start] - [Administrative Tools] - [Computer Management]. The [Computer Management] window appears.
2. Click [Disk Management] under [Storage] in the console tree.
3. <If you are using the tower model>  
Unlock the front door lock with the security key and open the front door.  
<If you are using the rack model>  
Unlock the front bezel with the security key and detach it.
4. Identify the slot to which you want to install the hard disk.  
Install a hard disk in an empty slot in the group, starting from the lower slot. (In the order of slot 0, slot 3, slot 1, slot 4, slot 2, and slot 5)

5. Hold the handle of the dummy tray to remove the tray.

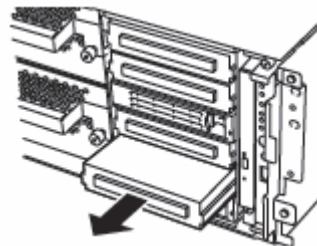

---

### IMPORTANT:

Keep and store the dummy tray with care.

---

6. Unlock the hard disk to be added.

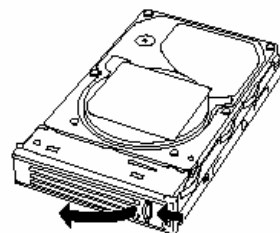

7. Firmly hold the handle of the hard disk to install and insert the hard disk into the slot.

---

**TIPS:**

- Insert the disk until the lever hook touches the server frame.
  - Check the orientation of lever. Insert the hard disk with the lever unlocked.
- 

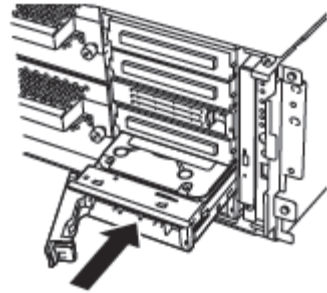

8. Slowly close the lever.

When the lever is locked, you will hear a click sound.

---

**IMPORTANT:**

Be careful not to pinch your finger(s) between the lever and handle.

---

---

**TIPS:**

Check the hook of the lever is engaged with the frame.

---

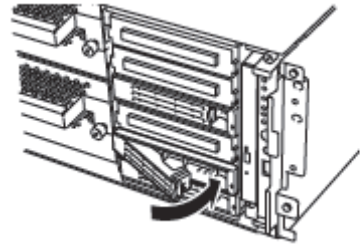

9. Connect the power cord.
10. Press the POWER switch to power on.
11. <If you are using the tower model>  
Close the front door and lock it with the security key.  
<If you are using the rack model>  
Install the front bezel and lock it with the security key.
12. See “RAID CONFIGURATION WHEN DISKS ARE ADDED” on page 8-10 to configure RAID.

---

## Removing 3.5-inch Hard Disk Drive

Follow the procedure below to remove the hard disk.

---

### IMPORTANT:

Make sure to read "ANTI-STATIC MEASURES" and "PREPARING YOUR SYSTEM FOR UPGRADE" before starting installing or removing options.

---

1. Shutdown Linux.

The system turns off automatically.

2. Disconnect all the power cords from the power outlet.

3. <If you are using the tower model>

Unlock the front door lock with the security key and open the front door.

<If you are using the rack model>

Unlock the front bezel with the security key and detach it.

4. Push the lever of the hard disk to unlock the handle.

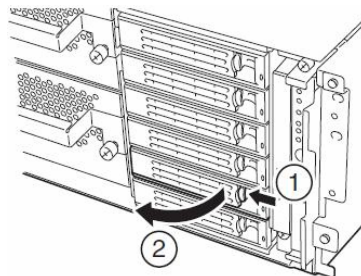

5. Hold the handle and hard disk to pull them off.

6. Install the dummy tray in an empty tray according to procedures described in "Installation."

Make sure to install the dummy slot in the empty slot to improve the cooling effect within the device.

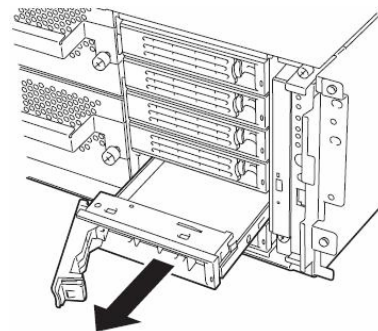

---

## Replacing 3.5-inch Hard Disk Drive

Follow the procedure below to remove the failed hard disk. If the hard disk fails, it should be replaced with new device with the server powered-on.

---

### IMPORTANT:

Make sure to read "ANTI-STATIC MEASURES" and "PREPARING YOUR SYSTEM FOR UPGRADE" before starting installing or removing options. You can replace disks during continuous operation.

---

### Replacing the Hard Disk Drive

1. Locate the failed hard disk.

When a hard disk fails, the DISK LED on the hard disk drive's handle illuminates amber.

The DISK Access LED of the amber lit disk also illuminates amber.

2. Remove the failed hard disk referring to "REPLACING 3.5-INCH HARD DISK DRIVE" on page 3-3 and "Removing 3.5-inch Hard Disk Drive" on page 8-8.

No need to shutdown Linux.

3. Refer to the steps in "Installing the hard disk" to install a new hard disk.

---

### TIPS:

- The hard disk to be installed for replacement must have the same specifications as its mirroring hard disk.
  - Use an unsigned hard disk to replace the failed one. If you use a signed disk, you need to restore the redundant configuration in the procedure of "How to Restore Redundant Configuration Manually" below.
- 

4. Restore the redundant configuration (see Chapter 3).

## RAID CONFIGURATION WHEN DISKS ARE ADDED

Use `ftdiskadm` to configure RAID when disks are added.

From “SCSI” – “Bring Up,” specify slot numbers and add the disks to the system. Then, from “RAID” – “New Disks,” configure RAID.

Following is an example of adding disks to Slot 2 and Slot 5 using `ftdiskadm`:

(Example of adding disks to the system)

```
#ftdiskadm
Command Action
 1 => RAID
 2 => SCSI
 9 Quit

Command:2

Command Action
 1 Bring Down(System Disk)
 2 Bring Up(System Disk)
 3 Status(System Disks)
 9 <= Return

Command:2

[Bring Up(System Disk)]
Which scsi SLOT?[0-5]:2    <<<Add the disk in Slot2>>>

Command Action
 1 Bring Down(System Disk)
 2 Bring Up(System Disk)
 3 Status(System Disks)
 9 <= Return

Command:2

[Bring Up(System Disk)]
Which scsi SLOT?[0-5]:5    <<<Add the disk in Slot5>>>

Command Action
 1 Bring Down(System Disk)
 2 Bring Up(System Disk)
 3 Status(System Disks)
 9 <= Return

Command:3    <<<Confirm that the disks are added to the system>>>

[SCSI DISK STATUS]
-- SYSTEM --
slot name use serial path
0 hada 2 V3W1N8RA0050B5CL0399 h1c0t010ACT h7c0t010HOT
1 -
2 hadc 0 V3W45ZVA0050B5CL0707 h1c0t210ACT h7c0t210HOT
3 hadb 2 V3W1RK5A0050B5CK040D h2c0t310ACT h8c0t310HOT
4 -
5 hadd 0 V3W1D30A0050B6120DED h2c0t510ACT h8c0t510HOT
```



```

Command Action
1 Bring Down(System Disk)
2 Bring Up(System Disk)
3 Status(System Disks)
9 <= Return

Command:9

```

### (Example of RAID configuration)

```

Command Action
1 => RAID
2 => SCSI
9 Quit

Command:1

Command Action
1 New Disks
2 Remove Half Disk
3 Repair Disk
4 Remove Full Disks
5 Status(Raid)
6 Status(All Disks)
9 <= Return

Command:1

[New Disks]
Which scsi SLOT?[1,2,4,5]:2          (*1)
Making the disk partition table: SLOT=2 SIZE=69809 (MB)
How many partitions?[1-12]:4        (*2)
  Input the SIZE of partition 1 [1-65620(MB)]:10000
  Input the SIZE of partition 5 [1-55620(MB)]:20000
  Input the SIZE of partition 6 [1-35620(MB)]:20000
                                partition 7: 19809
Are you sure to create?[y/n]:y

```

Now the creation of RAID configuration begins and the process is completed unless there is any problem. For RAID status, user “Status(Raid).”

#### Notes:

- 1: Before configuring RAID, insert disks to slots and add them to the system. Insert the disks to make pairs in Slot1 and Slot4, and Slot 2 and Slot 5. In this example, Slot 2 and Slot 5 are paired.
- 2: Enter the number of partitions to create. Then, assign the capacity in MB to each partition. Values of the last partition will be assigned automatically. The partition numbers begin with 1 and the next number is 5 and the following numbers are in ascending order. A certain amount of capacity is reserved for the last partition. Therefore, the specifiable range is smaller than actual disk capacity. The actual partition size varies slightly depending on the disk structure.

View the status of disks and confirm that the disks are added properly:

```

Command Action
 1 New Disks
 2 Remove Half Disk
 3 Repair Disk
 4 Remove Full Disks
 5 Status(Raid)
 6 Status(All Disks)
 9 <= Return

Command:5

[Status(Raid)]
Name Partition Status Member
-----
md6          resync=DELAYED (2) hadc7 (5) hadd7
md5          resync=DELAYED (2) hadc6 (5) hadd6
md4          resync=DELAYED (2) hadc5 (5) hadd5
md3          resync3.9%      (2) hadc1 (5) hadd1
md1 /         duplex          (0) hada2 (3) hadb2
md2          duplex          (0) hada3 (3) hadb3
md0 /boot     duplex          (0) hada1 (3) hadb1
    
```

**TIPS:**

- If you attempt to start `ftdiskadm` more than once at a time, “Cannot start” is displayed. If this message is displayed even when only one `ftdiskadm` is started, it may have been terminated without clearing the information. In such a case, run `ftdiskcleanup` and then start `ftdiskadm`.
  - The trace log of `ftdiskadm` is recorded to the `/var/log/ftdiskadm` directory. If the files occupy a large part of the disk space, delete them from the oldest.
  - Boot disks are inserted into the Slot0 and Slot3 normally. If you can only boot the system in the simplex mode, insert a boot disk into the Slot0 and boot the system.
  - After the disk is expanded and the system is restarted, the name of the disk device used by `diskdump` is changed. Refer to “DUMP INITIALIZATION” and modify `"/etc/sysconfig/diskdump."`
  - Use “RAID” - “Remove Full Disks” of `ftdiskadm` only when it is required because it deletes the `md` device from the system. To restore the deleted `md` device, the system needs to be restarted.
-

### 5.25-INCH DEVICE

The server has two slots to which you can install magnetic tape backup devices. You need a SCSI controller, sold separately, to install a backup device

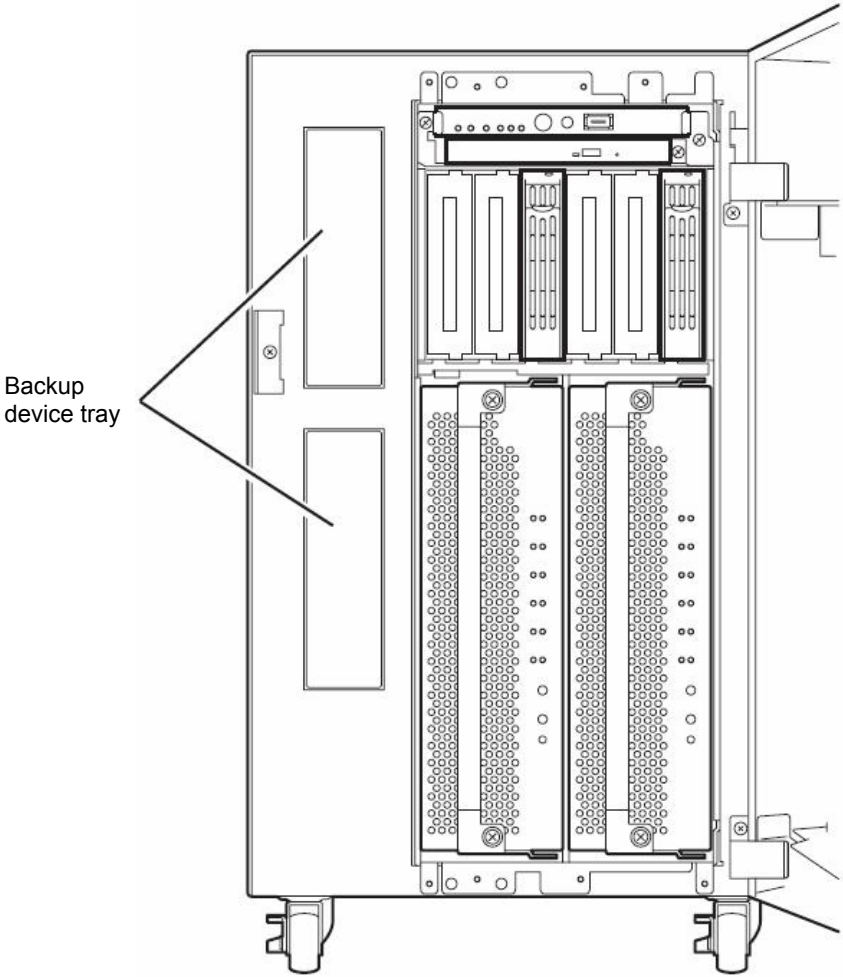

### Installing 5.25-inch Device

1. See page 8-4 to prepare for installation.
2. Loosen screws to remove the side cover.
3. Loosen screws to remove the tray for adding devices.
4. Remove the four screws securing the dummy cover, and remove the dummy cover.

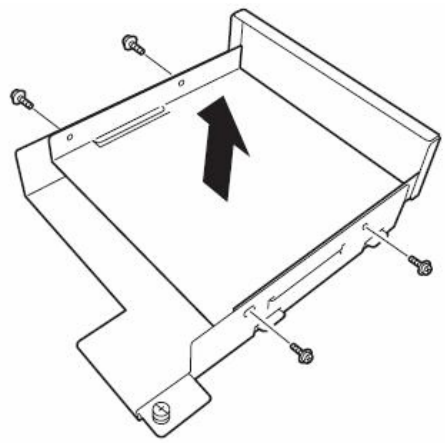
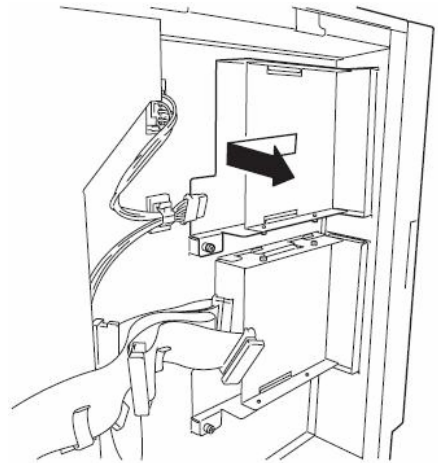
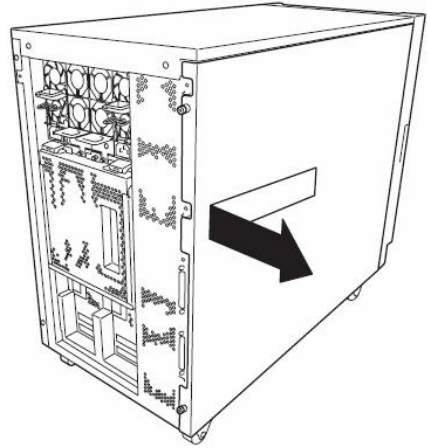

5. Fix the device to the tray for adding devices with the four screws.

---

**TIPS:**

Referring to the manual that comes with the 5.25-inch device you are to install, set the TermPower to Enable.

---

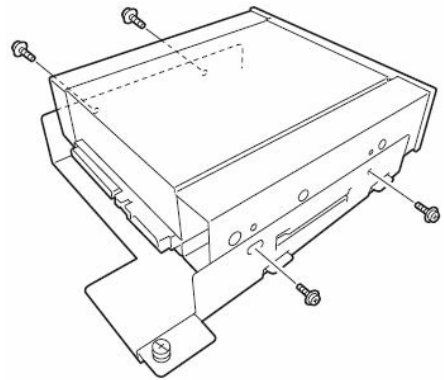

6. Gently insert the device into the tray and secure it with the screw.

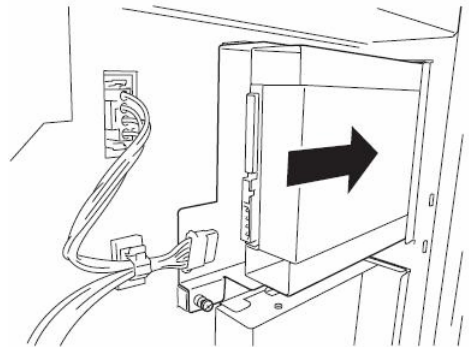

7. Connect the SCSI cable and power cords to the device.

---

**IMPORTANT:**

Distorted connector pins or loose connections may cause malfunction. Make sure that the device and cable connectors are connected correctly.

---

8. Secure the side cover with the screws.
9. Set up the SCSI BIOS referring to the manual shipped with the SCSI controller.
10. Install the device driver of the installed device.

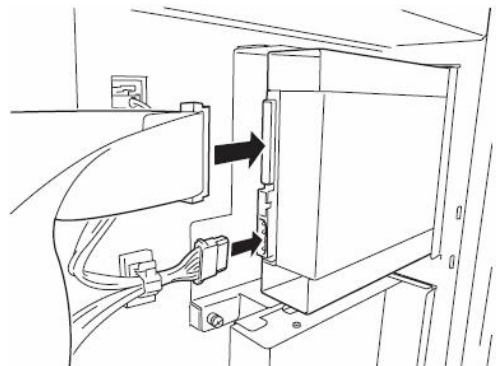

---

## Removing 5.25-inch Device

Removal is the reverse of the installation.

## CPU/IO MODULE

To replace a CPU (processor, DIMM (memory), PCI card, you need to remove the CPU/IO module.

---

### IMPORTANT:

- Ask your sales agent to replace the CPU/IO module and components of the CPU/IO module.
  - Make sure to read "ANTI-STATIC MEASURES" and "PREPARING YOUR SYSTEM FOR UPGRADE" before installing or removing options.
  - To install or remove CPU or DIMM, first power off the server before removing the CPU/IO module.
  - Removing the module being operating may cause unexpected trouble. Use the management software (e.g., Server Maintenance Utility or NEC ESMPRO Manager) to identify the module to be removed so that the module is removed when it is stopped, without fail  
Then remove the relevant module after verifying the Status LED on the CPU/IO module. See Chapter 2 “LEDs” for details of the Status LED.
  - After installing CPU/IO module, always power on the module using the power switch.
- 

---

## Precautions

When replacing a CPU/IO module, replace one module and wait until dual configuration is established to replace the other module. If you replace the both modules simultaneously, establishing dual CPU/IO module configuration, which can result in interruption of the whole system. (See Chapter 7 “Troubleshooting.”)

## Removing CPU/IO Module

Follow the procedure below to remove the CPU/IO module.

The 320Fb-L model is used in the example quoted here. However, steps you should take are the same for other models.

1. Stop the CPU/IO module you want to remove.

To this end, use the Server Maintenance Utility of the NEC ESMPRO Agent installed to your server or the Data Viewer of the NEC ESMPRO Manager.

For the detailed procedure, see "Maintenance of NEC Express5800/ft series" of "NEC ESMPRO Agent and Manager" in Chapter 5.

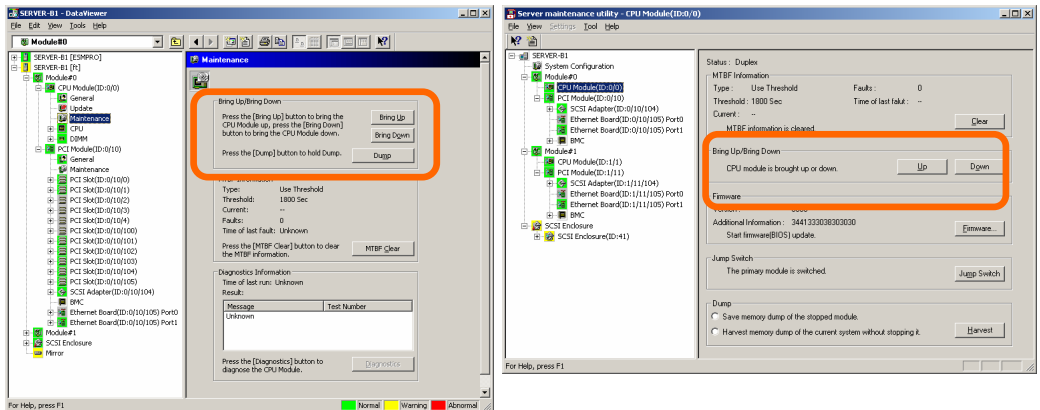

NEC ESMPRO Manager

Select [ft] - [CPU Module] - [CPU Module (to be removed)] - [Maintenance] - [Bring Up/Bring Down] - [Bring Down].

Server Maintenance Utility

Select [FTServer] - [CPU Module] - [CPU Module (to be removed)] - [Bring Up/Bring Down] - [Down].

Repeat the operation mentioned above for the IO module and confirm that the status of the CPU/IO module and the IO module are "Removed."

2. If the module POWER LED of the module to be removed is illuminated, press the module POWER switch to power off the module.
3. <If you are using the tower model>

Unlock the front door lock with the security key to open the front door.

<If you are using the rack model>

Unlock the front bezel with the security key and detach it.

4. Loosen the screws securing the CPU/IO module handle to press down the handle.

The lock is unlocked and the CPU/IO module is pulled out.

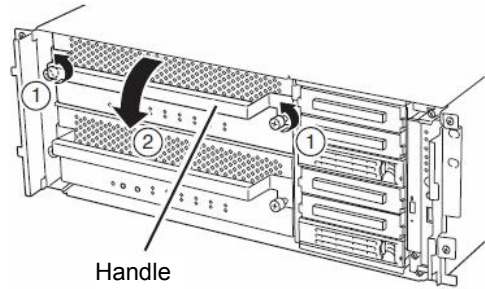

---

**IMPORTANT:**

Before you pull out a CPU/IO module, check the rear of the server to make sure cables for connection with peripheral equipment or network are disconnected. If any cables are connected, keep a record of where the cables are connected and then disconnect all cables connected to the module you are to pull out.

---

5. Hold the release levers of the CPU/IO module and pull it off.

---

**IMPORTANT:**

- Do not hold part other than the handle to pull the module.
  - Handle the CPU/IO module carefully. Do not drop the module or bump it against parts in the device when you remove it.
- 

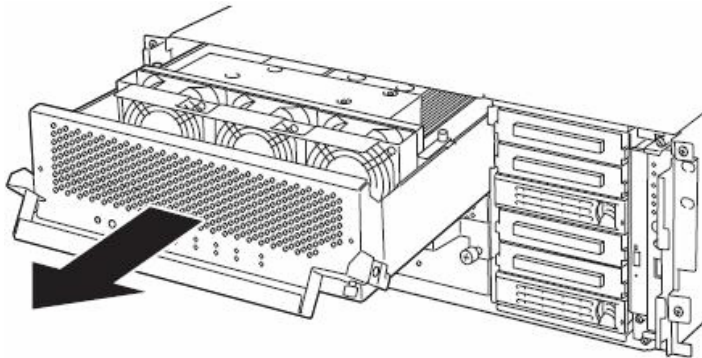

6. Carefully place the CPU/IO module on a flat and sturdy table.

Avoid the dusty or humid place.

This allows you to access the devices in the CPU/IO module. For more information on how to handle these devices, see the associated sections.



## Installing CPU/IO Module

Follow the procedure below to install the CPU/IO module:

The 320Fb-L model is used in the example quoted here. However, steps you should take are the same for other models.

---

### IMPORTANT:

Make sure to read "ANTI-STATIC MEASURES" (page 8-3) and "PREPARING YOUR SYSTEM FOR UPGRADE" (page 8-4) before starting installing or removing options.

---

1. Firmly hold the CP/IOU module with both hands and insert it into the rack.

Hold the CPU/IO module in such a way that its back panel connector faces the back of the rack and engage the guides of the module and chassis, and insert it slowly.

2. Hold the handle to push the module as far as it goes.

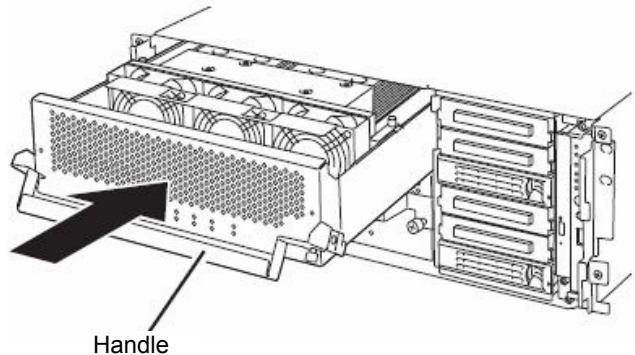

3. Put the handle back in the position where it was.

The installed CPU/IO module will start automatically.

---

### IMPORTANT:

Connect the cables that you disconnected before removing the CPU/IO module to where they were originally connected. Connect cables while the handle is leaned toward you.

---

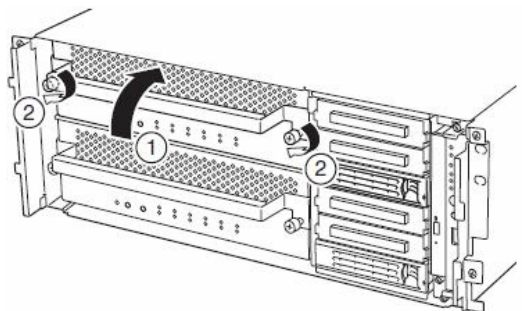

4. Secure the handle with the screws.

---

### IMPORTANT:

- Secure the handle with the screws. If it is not secured by the screws, the CPU/IO will not be powered on.
  - In some system statuses or settings, auto start up or integration does not take place when the module is connected. In such a case, check the status by using the Server Maintenance Utility or NEC ESMPRO Manager data viewer, and then power on by the module POWER switch or start up the IO and CPU modules.
  - After installing CPU/IO module, always power on the module using the power switch.
-

## DIMM

The DIMM (dual inline memory module) is installed to the DIMM socket in the CPU/IO module on the NEC Express5800/ft series.

The CPU/IO module board is equipped with six sockets. Two DIMMS are installed on the DIMM slot A1 and B1 as standard equipment. (The standard DIMMs can be replaced with other DIMMs.)

320Fb-L and 320Fb-LR models: 512MB DIMM×2

DIMMs should be installed to these sockets, starting from the lowest socket number.

---

### TIPS:

- You can add memory up to:  
320Fb-L and 320Fb-LR models: 6GB (1GB x 6)
  - In the error messages and logs in POST NEC ESMPRO, or Off-line Maintenance Utility, the DIMM connector may be described as “group.” The number next to “group” corresponds to the connector number shown in the figure on the next page.
- 

### IMPORTANT:

- The DIMM is extremely sensitive to static electricity. Make sure to touch the metal frame of the server to discharge static electricity from your body before handling the DIMM. Do not touch the DIMM terminals or onboard parts with a bare hand or place the DIMM directly on the desk. For more information on static electricity, see “ANTI-STATIC MEASURES.”
  - Make sure to use the DIMM authorized by NEC. Installing a third-party DIMM may cause a failure of the DIMM as well as the server. Repair of the server due to failures or damage resulted from installing such a board will be charged.
  - Before adding or removing DIMMs, power off the server and detach the CPU/IO module.
  - Make sure to read “ANTI-STATIC MEASURES” (page 8-3) and “PREPARING YOUR SYSTEM FOR UPGRADE” (page 8-4) before installing or removing options.
-

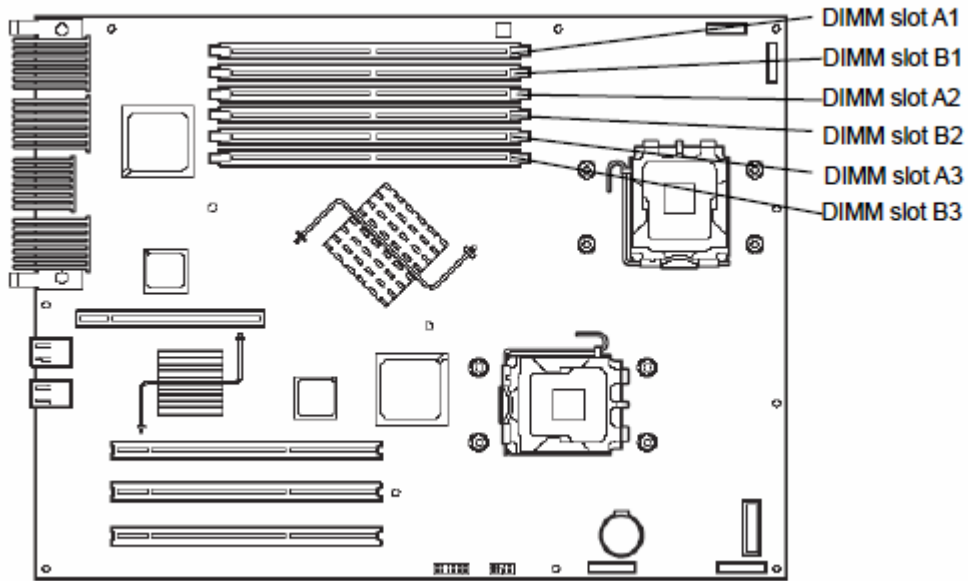

Motherboard of the CPU/IO module

## Precautions

Note the following to install or replace DIMM.

- The DIMMs with the same number are linked among the groups. When a DIMM is added to one group, another identical DIMM should be installed to the socket with the same number in another group. This rule is applied to the case of removal.
- The linked DIMMs should be of the same product with the same performance.
- DIMMs should be installed in sockets from the lowest socket number to the highest socket number.

---

## Installing DIMM

Follow the procedure below to install the DIMM.

1. Shut down OS.  
The sever turns off automatically.
2. Disconnect the power cords from the outlets.
3. Remove the CPU/IO module referring to page 8-17.
4. Check to be sure in which socket you are mounting the DIMM.
5. Remove the connector cover from the socket.

A DIMM connector cover is installed to the open socket. When the levers on both ends of the connector are opened, the DIMM connector cover is unlocked and you can remove the cover.

---

**IMPORTANT:**

Keep the removed DIMM connector cover.

---

6. Insert a DIMM into the DIMM socket vertically.

---

**TIPS:**

Pay attention to the orientation of the DIMM. The terminal of the DIMM has a cutout to prevent misinsertion.

---

After the DIMM is completely inserted into the socket, the levers are automatically closed.

7. Mount the CPU/IO module referring to page 8-19.
8. Reattach the removed memory duct and secure it with the tree screws.
9. Connect the power cords.
10. Press the POWER switch to power on the server.
11. Verify that POST displays no error message.

If POST displays an error message, write it down and see the POST error message list on page 7-4.

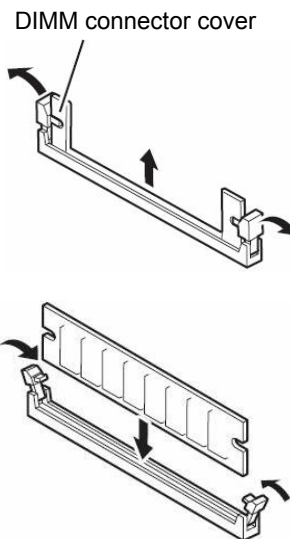

---

## Removing DIMM

Follow the procedure below to remove the DIMM.

---

### TIPS:

Unless at least two DIMMs are installed, the server does not work.

---

1. Shutdown OS.  
The system turns off automatically.
2. Disconnect the power cords from the outlets.
3. Remove the CPU/IO module referring to page 8-17.
4. Open the lever on both ends of the target DIMM socket to unlock the DIMM. Then, remove the DIMM.
5. Mount the CPU/IO module referring to page 8-19.
6. Connect the power cords.
7. Press the POWER switch to power on the server.
8. Verify that POST displays no error message.

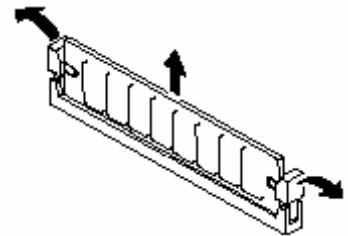

If POST displays an error message, write it down and see the POST error message list on page 7-4.

## Replacing DIMM

Follow the procedure below to replace a failed DIMM.

1. Identify the failed DIMM using the Data Viewer of NEC ESMPRO Manager.

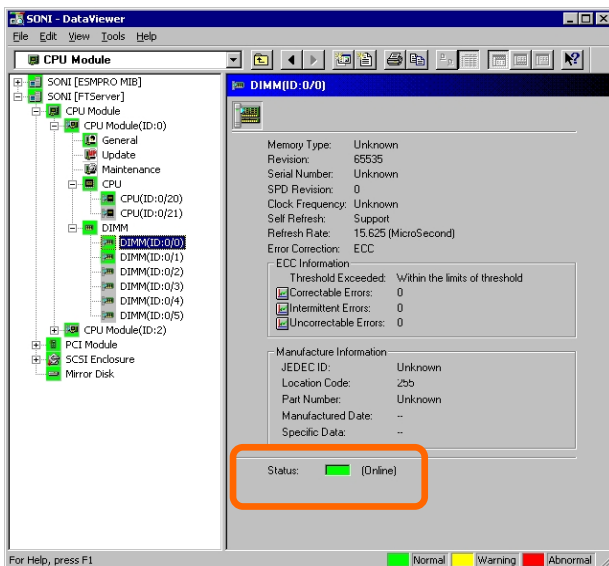

2. Remove the CPU/IO module referring to page 8-17.
3. Replace the DIMM
4. Install the CPU/IO module referring to page 8-19.
5. Start up the CPU/IO module using NEC ESMPRO Manager or Server Maintenance Utility.

## PROCESSOR (CPU)

In addition to the standard CPU (Intel® Xeon® Processor), you can add one CPU to make a multi-processor system.

---

### IMPORTANT:

- The CPU is extremely sensitive to static electricity. Make sure to touch the metal frame of the server to discharge static electricity from your body before handling the CPU. Do not touch the CPU terminals or onboard parts with a bare hand or place the CPU directly on the desk. For more information on static electricity, see “ANTI-STATIC MEASURES.”
  - Do not use the system before checking to see it works correctly.
  - Make sure to use the CPU specified by NEC. Installing a third-party CPU may cause a failure of the CPU as well as the server.
  - Before adding or removing a CPU, power off the server and then remove the CPU/IO module.
  - Make sure to read "ANTI-STATIC MEASURES" and "PREPARING YOUR SYSTEM FOR UPGRADE" before starting installing or removing options.
- 

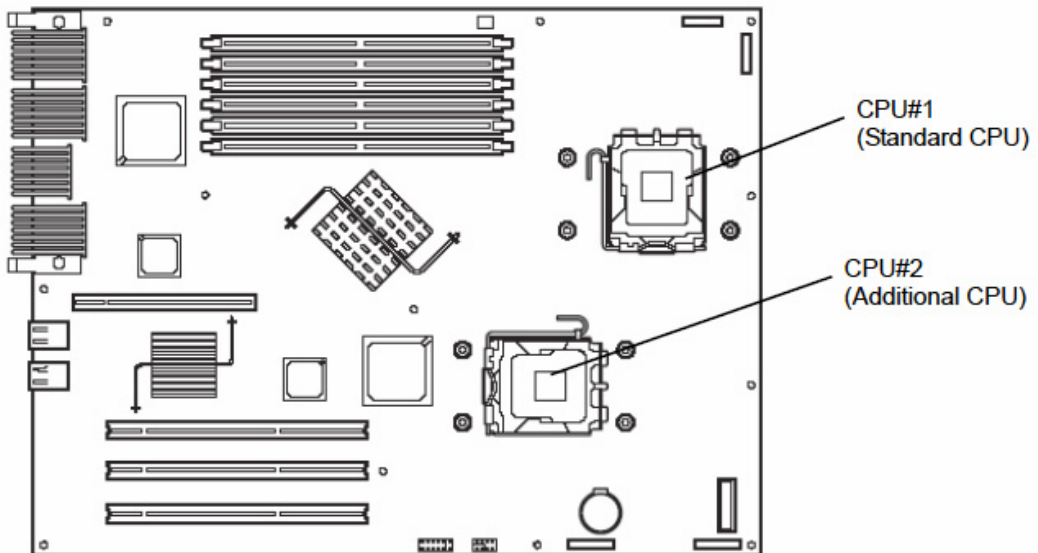

---

## Installing CPU (Model with Air-cooling Kit)

Follow the steps below to mount a CPU (model with air-cooling kit).

Information provided here is for the 320Fb-L and 320Fb-LR models, which have a heat sink installed.

1. Shut down OS.  
The system turns off automatically.
2. Unplug the power cords.
3. Remove the CPU/IO module referring to page 8-17.
4. Remove the two screws securing the cooling fan unit, remove the cable, and then remove the cooling fan unit.

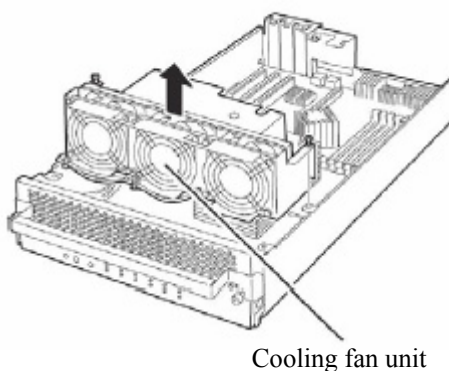

5. Check to be sure of the location of the CPU socket.
6. Detach the socket cover on the CPU socket.

---

**IMPORTANT:**

Keep the socket cover.

---

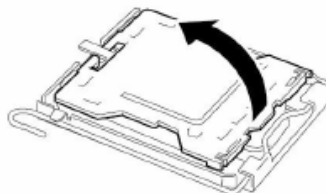

7. Lift the socket lever.

---

**IMPORTANT:**

Open the lever fully. It can be opened 120° or more.

---

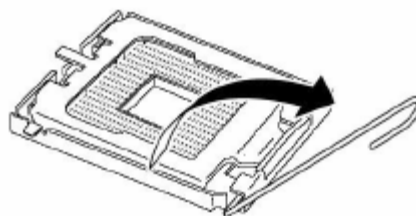



- Lift the CPU socket holder.



- Place the CPU on the socket carefully.

**TIPS:**

Pay attention to the orientation of the CPU. The CPU and socket have pin marks to prevent misinsertion. Check the pin marks of the CPU and the socket and insert the CPU correctly.

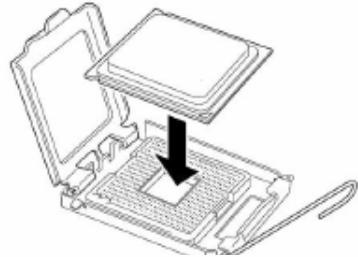

- After pressing the CPU softly against the socket, place the CPU socket holder back to its original place.



- Return the socket lever back to its original place.



- Place the heat sink on the CPU, and secure it with the 4 screws. Loosely fasten the screws in the cross-coupling way, then fasten them tightly.

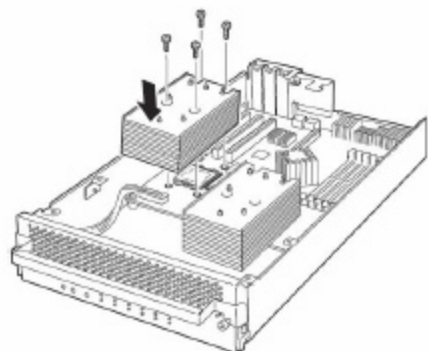

- 13.** Confirm that the heat sink mounted on the CPU is level with the motherboard.

---

**IMPORTANT:**

- If the heat sink is leaning, remount it and then mount it again.  
The heat sink cannot be mounted correctly if:
    - the CPU is not mounted correctly
    - the screws are not fully fastened.
  - Do not hold the fastened heat sink to move the CPU.
- 

- 14.** Insert the cable and fix the cooling fan unit.

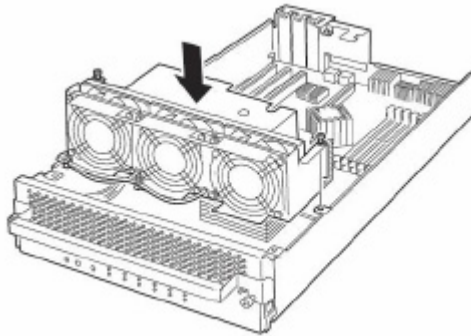

- 15.** Install the CPU/IO module referring to page 8-19.
- 16.** Connect the power cords.
- 17.** Press the POWER switch to power on the server.
- 18.** Verify that POST displays no error message. If POST displays an error message, write it down and check the POST error message list on page 7-4.

---

## Removing CPU (Model with Heat Sink)

When you remove a CPU, prepare for removal referring to the steps from 1 to 4 of “Installing CPU (Model with Air-cooling Kit).” Then follow the installation steps from 12 to 7. To remove the heat sink, remove the screws, move the heat sink horizontally a little, and then remove it.

---

### IMPORTANT:

- Do not remove the CPU unless it is faulty.
  - After operation, the cool sheet at the bottom of the heat sink may stick to the CPU because of the heat. When you dismount the heat sink, turn it sideways lightly to make sure that it is not sticking to the CPU. If it is sticking to the CPU and you remove it, the CPU or the socket may be damaged.
- 

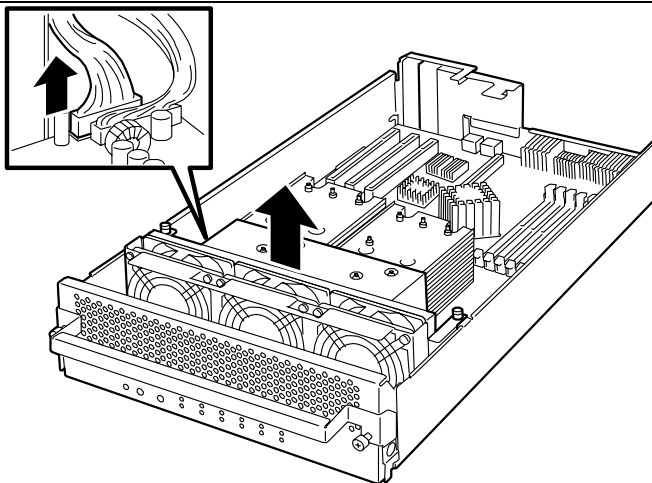

- 
1. After removing the heat sink and the CPU, attach the socket cover on the CPU socket, mount the cooling fan unit, and then connect the cable.
  2. Install the CPU/IO module referring to page 8-19.
  3. Connect the power cords.
  4. Press the POWER switch to power on the server.
  5. Check POST to see if there is any error message. If there is any error message, write it down and see the error message list on page 7-4.

## Replacing CPU

Follow the steps below to replace a failed CPU:

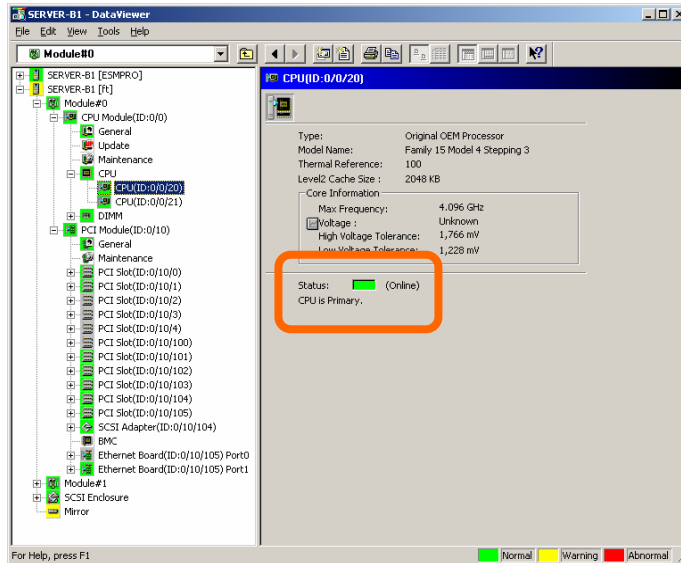

1. Use Data Viewer of NEC ESMPRO Manager to identify the failed CPU.
2. Remove the CPU/IO module referring to page 8-17.
3. Replace the CPU.
4. Install the CPU/IO module referring to page 8-19.

The installed CPU/IO module will start automatically.

---

## ft Remote Management Card

ft Remote Management Card function is compatible only with 320Fb-L, 320Fb-LR models. An ft Remote Management Card needs to be installed on each CPU/IO module in order to use ft Remote Management Cards.

---

### IMPORTANT:

- Even when the server is powered off (the POWER LED is off), the power is supplied to the server if the power cords are connected. Therefore, before adding any ft Remote Management Card, you must remove all power cords from the AC inlets. If ft Remote Management Cards are installed with the power cords connected, the server and the ft Remote Management Cards may be damaged.
- ft Remote Management Cards can only be installed into the dedicated slots. If they are installed into other slots such as slots for PCI EXPRESS, the server and the ft Remote Management Cards may be damaged.
- Since the sensor information specific to the server is not written to the added ft Remote Management Card, the messages below are displayed and the startup process temporarily stops when starting the server (POST). The server may be in such a state when the NEC logo screen is displayed and the startup process is stopped. Press **ESC** to delete the logo screen and check the diagnostic message.

H/W Configuration of BMC is corrupted.

!! Update BMC H/W Configuration by configuration tool !!

!! Refer to BMC configuration manual !!

When the messages above are displayed, press F1 or POST starts if you wait for a while. NEC EXPRESSBUILDER starts by inserting the EXPRESSBUIDER CD-ROM that comes with the server into the CD-ROM drive. Select the [Tools] menu - [Initialize Remote Management Card] from the NEC EXPRESSBUILDER main menu and write the sensor information specific to the server.

Running the initialize Remote Management Card resets the AC LINK setting (Server-AC LINK) of the BIOS setup to the initial value "Last State." If you have changed the value, you will need to set it again.

- The ft Remote Management Card is extremely sensitive to static electricity. Make sure to touch the metal frame of the server to discharge static electricity from your body before handling the PCI board. Do not touch the board terminals or its parts with a bare hand or place the board directly on the desk. For more information on static electricity, see "ANTI-STATIC MEASURES" on page 8-3.
- Make sure to read "ANTI-STATIC MEASURES" on page 8-3 and "PREPARING YOUR SYSTEM FOR UPGRADE" on page 8-4 before starting installing or removing options.



---

## Installing ft Remote Management Card

Follow the procedures below and install ft Remote Management Card.

1. Remove CPU/IO module referring page 8-17.

---

**TIPS:**

If PCI board is already installed to the CPU/IO module, remove the PCI board referring to page 8-37.

---

2. Remove PCI rear bracket installed to the CPU/IO module as a standard with two screws.

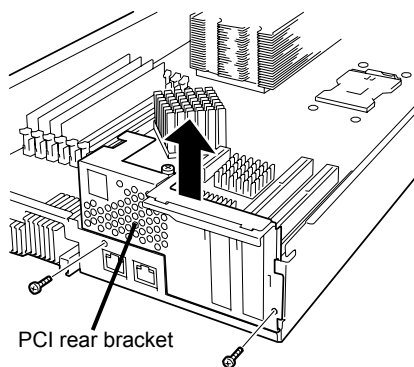

3. Remove the blank cover for LAN connector of ft Remote Management Card. Grab the top and bottom of the blank cover to unlock and remove it.

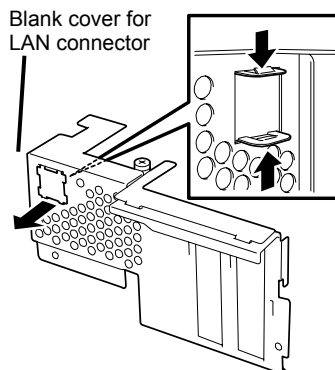

4. Install ft Remote Management Card to PCI rear bracket with one screw.

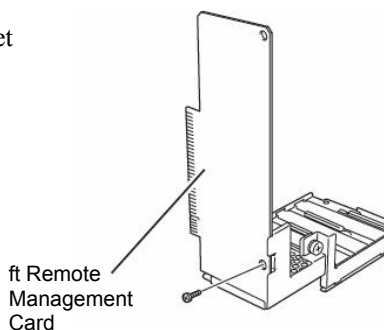

5. Check the slot for ft Remote Management Card and remove the connector cap installed in the slot.

---

**IMPORTANT:**

Keep and store the removed connector cap with care.

---

6. Insert ft Remote Management Card slowly against the connecting part to the slot board on the motherboard.
7. Insert the connecting part of the card against the slot and secure it with two screws.

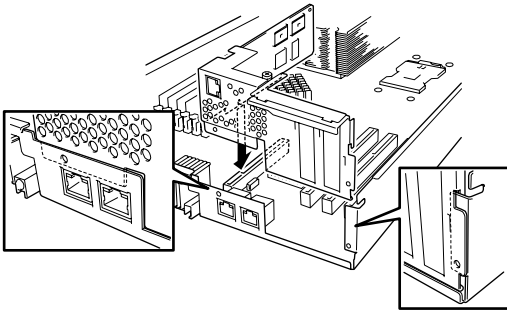

---

**IMPORTANT:**

If you have trouble installing the card, remove the card once and install it again. Be careful since the card gets damaged if you press it too hard.

---

---

**TIPS:**

If PCI board is removed in the first step, remount it referring to page 8-36.

---

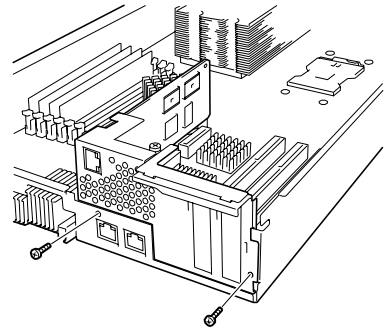

8. Install CPU/IO module referring to page 8-19.
9. Turn ON the power by pressing the POWER switch of installed CPU/IO module.

---

## Removing ft Remote Management Card

For removing PCI riser card, follow the reverse procedure of the installation and remove the connector cap.

## PCI BOARD

Up to three PCI boards can be installed to the CPU/IO module.

---

### IMPORTANT:

- The PCI board is extremely sensitive to static electricity. Make sure to touch the metal frame of the server to discharge static electricity from your body before handling the PCI board. Do not touch the PCI board terminals or onboard parts by a bare hand or place the PCI board directly on the desk. For more information on static electricity, see "ANTI-STATIC MEASURES" on page 8-3.
- Make sure to read "ANTI-STATIC MEASURES" and "PREPARING YOUR SYSTEM FOR UPGRADE" before starting installing or removing options.

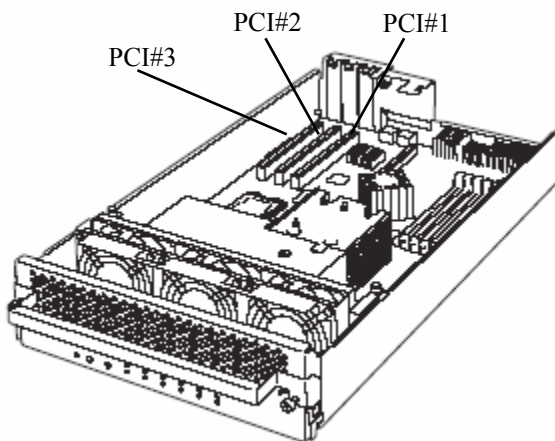

---

Note the following to install or replace PCI board.

- To make a dual PCI board configuration, install the same type of board (i.e., having the same specifications and performance) to the same slot in another group.  
When a PCI board is installed to one group, another identical PCI board should be installed to the same slot in another group. This rule is applied to the case of removal.
- Install the PCI boards, starting from the one with the smallest number.



List of option PCI boards and installable slots:

N-code	Product name	PCI-1	PCI-2	PCI-3	Remarks
	PCI slot performance	64bit/100MHz			
	Slot size	Low Profile			
	PCI board type	3.3V			
	Mountable board size	MD2			
N8804-002	1000BASE-T 1ch board set	○	○	○	Only one board can be mounted when N8804-004 or N8803-033 is installed
N8804-003	1000BASE-SX 1ch board set	○	○	○	
N8804-004	1000BASE-T 2ch board set	○	○	○	Up to one board can be mounted per CPU/IO module
N8803-032	SCSI board	○	○	○	
N8803-033	Fibre Channel board set	○	○	○	

---

## Installing PCI Board

Follow the procedure below to install the board to be connected to the PCI board slot.

---

**TIPS:**

To install the PCI board, make sure the shape of the board connector matches with the shape of the PCI board slot connector.

---

1. Remove the CPU/IO module referring to the page 8-17.
  2. Identify the slot to which you want to install a PCI board and remove the connector cap.
- 

**IMPORTANT:**

Carefully keep the removed connector cap.

---

3. Remove the PCI bracket by loosening the screw and remove the slot cover of an expansion slot.
- 

**IMPORTANT:**

Keep and store the removed slot cover with care.

---

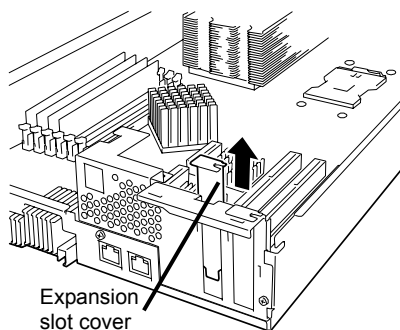
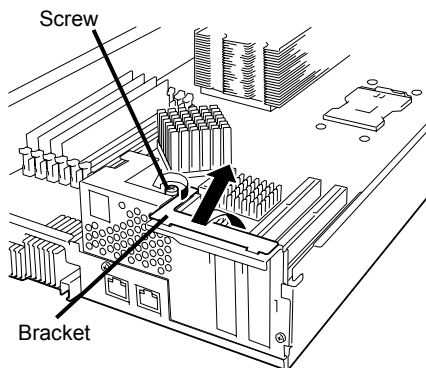

4. Remove the connector cap installed in the slot in which the board is installed.
- 

**TIPS:**

To install the PCI board, make sure the shape of the board connector matches with the shape of the PCI board slot connector.

---

**IMPORTANT:**

Keep and store the removed connector cap with care.

---

5. Gently insert the slot on the board against the connecting part of the board.

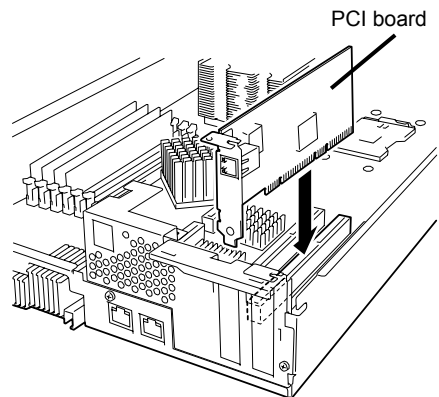

6. Insert the board for connecting part of the board to securely connect to the slot.

---

**IMPORTANT:**

If you have trouble installing the board, remove the board once and install it again. Be careful since the board gets damaged if you press it too hard.

---

7. Install the PCI bracket and secure the board.

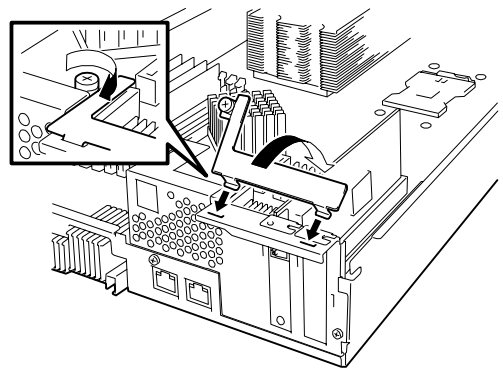

8. Install CPU/IO module referring to the page 8-19.
9. Turn ON the power by pressing the POWER switch of installed CPU/IO module.

---

**Removing PCI Board**

Removal of PCI board card follows the reverse procedure of the installation and installs the expansion slot cover.

---

## Replacing PCI Board

Follow the procedure below to replace the failed PCI board.

1. Check the PCI board LED and identify the failed PCI board.

When the PCI board is failed or incorrectly installed, the three LEDs associated with the PCI board slot are being turned off.

2. Remove the CPU/IO module referring to the page 8-17.
3. Remove the PCI bracket, then remove the PCI board.
4. Replace the board and fasten it.
5. Install the CPU/IO module referring to the page 8-19. .
6. Connect the network cable and cables for PCI boards.
7. The installed CPU/IO module will start automatically.
8. Confirm that the PCI board is correctly recognized by POST and OS.

---

## Setup of Optional PCI Board

- To enable the fault-tolerant feature of the optional device, the identical PCI boards must be installed to the slots with the same number in CPU/IO module#0 and CPU/IO module#1.
- The BIOS settings need to be modified when mounting some optional PCI boards. To change the BIOS settings, start the BIOS Setup Utility to change the [Boot Monitoring] configuration in [Server] – [Monitoring Configuration]. See “Monitoring Configuration” on page 4-25 for more details.
- For the supported connecting devices, contact your sales agent.

### **N8804-002 1000BASE-T 1ch board set**

### **N8804-003 1000BASE-SX 1ch board set**

### **N8804-004 1000BASE-T 2ch board set**

---

#### **IMPORTANT:**

For LAN cable's connector, use a RJ-45 connector which is compliant with IEC8877 standard. If any other connector is used, it may not be removed easily.

---

- List of slots to install optional PCI boards  
Refer to “List of option PCI boards and installable slots:” on page 8-35.
- Installation procedure  
NEC Express5800/ft series sets dual configuration with optional PCI boards in pairs. See “Step 6: Set Dual LAN Card Configuration.”

### **N8803-032 SCSI board**

- List of slots to install optional PCI boards  
Refer to “List of option PCI boards and installable slots:” on page 8-35.
- Driver installation procedure  
The driver for N8803-032 SCSI board is included in the OS, so its installation is not necessary.

## N8803-033 Fibre Channel Board Set

- List of slots to install optional PCI boards

“List of option PCI boards and installable slots:” on page 8-35.

- Driver installation procedure

The driver for N8803-033 Fibre Channel board is included in OS, so its installation is not necessary. However, the following needs to be added under `/etc/modprobe.conf` depending on your environment.

```
<N8190-119>  
options lpfc lpfc_topology=0
```

```
<Others>  
options lpfc lpfc_topology=6
```

After setup, reboot the system:

```
#sync  
#reboot
```

---

### IMPORTANT:

- StoragePathSavior is required for connecting NEC Storage using N8803-033 Fiber Channel boards.
  - Mount N8803-033 Fibre Channel boards after completing the OS installation. They are used in a pair or in a set of four. Mount each controller on the slot of the same position of each PCI module.
-

# Appendix A

## Specifications

Item		NEC Express5800/320Fb-L	NEC Express5800/320Fb-LR
		N8800-100F, EXP320B	N8800-101F, EXP320A
CPU	Type	Dual-Core Intel® Xeon® Processor × 1	
	Clock/second cache	1.6GHz/4MB	
	Number of processors	1 processor (the number of processors installed per module)	
	Maximum	Up to 2 processors (the number of processors installed per module)	
Chipset		GeminiEngine (NEC original chipset)	
Memory	Standard	None	
	Maximum	12GB (The standard DIMM must be replaced.)	
	Expansion unit	2 DIMMs (512MB × 2 / 1GB × 2 / 2GB × 2)	
	Memory module	DDR533 SDRAM DIMM (Registered Type)	
Error check		ECC	
Graphics (VRAM)		ES1000 (32MB)	
Auxiliary input device	Floppy disk (standard)	None	
	Hard disk (standard)	None	
	Hard disk (maximum)	1.8TB* (300GB × 6) * The user area is reduced to a half of the physical capacity due to software mirroring.	
	CD-ROM (standard)	ATAPI interface × 1 (Load on tray type, x24 speed)	
File bay	5.25 inch	2 slots	None
	3.5 inch	6 slots	
Additional slot	PCI, 64-bit	3 slots (Low profile)	
LAN interface		1000BASE-T/100BASE-TX/10BASE-T (2 ports)	
External interface	USB	4-pin connector (3 ports). Keyboard occupies one port.	
	Network	RJ-45 (4 ports)	
	Display	MINI D-sub 15-pin (1 port)	
Cabinet design		Tower type	Rack-mount type
External dimensions		310 mm (w) × 543 mm (h) × 715 mm (d)	485 (w) × 177 (h) × 635 (d) mm
Weight		59 kg (Max. 66 kg)	38 kg (Max. 47kg)
Power supply		100 to 120 VAC ±10%, 200 to 240 VAC ±10%, 50/60 Hz ±1 Hz	
Power consumption		829 VA, 819 W	
Environmental requirements	In operation	Temperature 10 to 35°C Humidity 20 to 80% RH (non-condensing)	
	In storage	Temperature -10 to 55°C Humidity 20 to 80% RH (non-condensing)	





# Appendix B

---

## I/O Port Addresses

The factory-set I/O port addresses for the server are assigned as follows:

Address	Chip in Use
00000000 - 0000000F	DMA controller
00000020 - 00000021	Programmable interruption controller
0000002E - 0000002F	Motherboard resource
00000040 - 00000043	System timer
0000004E - 0000004F	Motherboard resource
00000060 - 00000060	Motherboard resource
00000061 - 00000061	System speaker
00000064 - 00000064	Motherboard resource
00000070 - 00000073	System CMOS/real-time clock
00000080 - 0000008F	DMA controller
000000A0 - 000000A1	Programmable interruption controller
000000C0 - 000000DF	DMA controller
000000E0 - 000000F0	Motherboard resource
000000F0 - 000000FF	Numerical data processor
00000274 - 00000277	ISAPNP read data port
00000279 - 00000279	ISAPNP read data port
000002E8 - 000002EF	Motherboard resource
000002F8 - 000002FF	Motherboard resource
000003B0 - 000003BB	PCI standard PCI-to-PCI bridge
000003B0 - 000003BA	Graphics controller (NEC GA Driver)
000003C0 - 000003DF	PCI standard PCI-to-PCI bridge
000003C0 - 000003DE	Graphics controller (NEC GA Driver)
000003E8 - 000003EF	Motherboard resource
000003F8 - 000003FF	Motherboard resource
000004D0 - 000004D1	Motherboard resource
00000540 - 0000055F	Motherboard resource
00000560 - 0000056F	Motherboard resource
00000600 - 0000061F	Motherboard resource
00000A79 - 00000A79	ISAPNP read data port
00000CA2 - 00000CA5	Motherboard resource
00000CF8 - 00000CFF	PCI configuration
0000FE00 - 0000FE20	Motherboard resource





**N8800-100F, EXP320B**  
**NEC Express5800/320Fb-L**

**N8800-101F, EXP320A**  
**NEC Express5800/320Fb-LR**

**User's Guide**

1st Edition  
1-2007  
856-126408-102-00