



N8800-147F, EXP320L

NEC Express5800/R320a-E4

N8800-148F, EXP320M

NEC Express5800/R320a-M4

User's Guide

1st Edition
1-2010
856-128382-111- A

PROPRIETARY NOTICE AND LIABILITY DISCLAIMER

The information disclosed in this document, including all designs and related materials, is the valuable property of NEC Corporation (NEC) and /or its licensors. NEC and/or its licensors, as appropriate, reserve all patent, copyright and other proprietary rights to this document, including all design, manufacturing, reproduction, use, and sales rights thereto, except to the extent said rights are expressly granted to others.

The NEC product(s) discussed in this document are warranted in accordance with the terms of the Warranty Statement accompanying each product. However, actual performance of each such product is dependent upon factors such as system configuration, customer data, and operator control. Since implementation by customers of each product may vary, the suitability of specific product configurations and applications must be determined by the customer and is not warranted by NEC.

To allow for design and specification improvements, the information in this document is subject to change at any time, without notice. Reproduction of this document or portions thereof without prior written approval of NEC is prohibited.

1st Printing, January 2010
Copyright 2010
NEC Corporation
7-1 Shiba 5-Chome, Minato-Ku
Tokyo 108-8001, Japan
All Rights Reserved
Printed in Japan



Keep this User's Guide handy for quick reference when necessary.

SAFETY INDICATIONS



To use NEC Express5800 series safely, follow the instructions in this User's Guide.

This guide explains components that pose a danger, types of dangers, and actions taken to prevent them; such components are labeled warning.

This guide and warning labels use "WARNING" and "CAUTION" to indicate a danger depending on the degree. These terms are defined as follows:



 WARNING	Indicates a danger that could lead to a death or serious injury.
 CAUTION	Indicates a danger that could lead to a burn, other injuries or damage to physical assets.

This guide uses the following three types of symbols to give indications and precautions against a danger. They are defined as follows:

	Indicates that there is a risk of danger. Each image symbolizes a particular type of danger. (Attention)
	Indicates what you must not do. Each image symbolizes a particular type of prohibition. (Prohibited actions)
	Indicates what you must do. Each image symbolizes a particular type of action necessary to avoid a danger. (Mandatory actions)

(Example)

Symbol to draw attention
Term indicating a degree of danger









 CAUTION	
 	<p>High temperature. Immediately after the power-off, system components such as hard disk are very hot. Wait the server to cool down completely before adding/removing some component.</p>

Symbol indicating a prohibited action (may not always be indicated)







Description of a danger

SYMBOLS USED IN THIS USER'S GUIDE AND WARNING LABELS



Attention

	Indicates a risk of an electric shock.
	Indicates a risk of a personal injury due to heat.
	Indicates a risk of catching your fingers.
	Indicates a risk of a fire or smoke.
	Indicates a general precaution or warning that is not defined herein.
	Indicates a risk of losing eyesight due to laser beam.
	Indicates a risk of an explosion.
	Indicates a risk of a personal injury.

Prohibited actions

	Indicates a general prohibition that is not defined herein.
	Do not touch the indicated area. There is a risk of an electric shock or fire.
	Do not touch with wet hands. There is a risk of an electric shock.
	Keep from flame. There is a risk of a fire.
	Avoid using water or liquid nearby. If it spills on the equipment, there is a risk of an electric shock or fire.
	Do not disassemble, repair, or modify the equipment. There is a risk of an electric shock or fire.

Mandatory actions

	Unplug the server. There is a risk of an electric shock or fire.
	Indicates a general action to take that is not defined herein. Make sure to follow the instructions.
	Be sure to provide earthing. Otherwise, an electric shock or fire may be caused.

NOTE: This equipment has been tested and found to comply with the limits for a Class A digital device, pursuant to Part 15 of the FCC Rules. These limits are designed to provide reasonable protection against harmful interference when the equipment is operated in a commercial environment. This equipment generates, uses, and can radiate radio frequency energy and, if not installed and used in accordance with the instruction manual, may cause harmful interference to radio communications. Operation of this equipment in a residential area is likely to cause harmful interference in which case the user will be required to correct the interference at his own expense.

BSMI Statement

警告使用者：

這是甲類的資訊產品，在居住的環境中使用時，可能會造成射頻干擾，在這種情況下，使用者會被要求採取某些適當的對策。

CCC Statement

声 明

此为 A 级产品，在生活环境中，该产品可能会造成无线电干扰。在这种情况下，可能需要用户对其干扰采取切实可行的措施。

KCC Statement

이 기기는 업무용으로 전자파적합등록을 한 기기이오니 판매자 또는 사용자는 이 점을 주의하시기 바라며 만약 잘못 판매 또는 구입하였을 때에는 가정용으로 교환하시기 바랍니다.

CE Mark Statement

Australia EMI:

NOTE: This is a Class A product. In domestic environment, this product may cause radio interference in which case the user may be required to take adequate measures.

Canada EMI:

This Class A digital apparatus meets all requirements of the Canadian Interference-Causing Equipment Regulations.

Cet appareil numérique de la classe A respecte toutes les exigences du Règlement sur le matériel brouilleur du Canada.

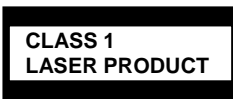

This system is classified as a CLASS 1 LASER PRODUCT. This label is located on the internal DVD-ROM installed in your system.

- NOTE: This product provides resistance against hardware faults with its redundant hardware modules. However, this does not mean complete fault-tolerance is assured. For example, there is a risk of system down when:
- A fatal fault occurs in software.
 - Both modules within a redundant hardware pair break down.
 - A fatal fault occurs in a non-redundant component, such as the clock generator circuitry or the interconnect backplane.
 - The entire system is cut off from AC power.

Trademarks and Patents

NEC EXPRESSBUILDER, NEC ESMPRO and NEC DianaScope are trademarks of NEC Corporation.

Microsoft, Windows, Windows Server, Windows NT, and MS-DOS are registered trademarks of Microsoft Corporation in the United States and other countries.

Intel and Pentium are registered trademarks of Intel Corporation.

AT is a registered trademark of International Business Machines Corporation in the United States and other countries.

Adobe, the Adobe logo, Acrobat, and the Acrobat logo are trademarks of Adobe Systems Incorporated.

Datalight is a registered trademark of Datalight, Inc. ROM-DOS is a trademark of Datalight, Inc.

Xeon is a trademark of Intel Corporation in the United States. DLT and DLTtape are trademarks of Quantum Corporation in the United States.

Mozilla is a registered trademark of Mozilla Foundation.

Netscape is a registered trademark of Netscape Communications Corporation in the United States and other countries.

Java is a registered trademark of Sun Microsystems, Inc in the United States and other countries.

All other product, brand, or trade names used in this publication are the trademarks or registered trademarks of their respective trademark owners.

Windows Server 2008 is the abbreviation for Microsoft Windows Server 2008 Standard operating system and Microsoft Windows Server 2008 Enterprise operating system. Microsoft Windows Server 2003 R2 Standard x64 Edition operating system and Microsoft Windows Server 2003 R2 Enterprise x64 Edition operating system or Microsoft Windows Server 2003 Enterprise x64 Edition operating system are called Windows Server 2003 x64 Edition for short. Microsoft Windows Server 2003 R2 32-bit Standard Edition operating system, Microsoft Windows Server 2003 R2 32-bit Enterprise Edition operating system, Microsoft Windows Server 2003 Standard Edition operating system and Microsoft Windows Server 2003 Enterprise Edition operating system are called Windows Server 2003 for short. Microsoft Windows 2000 Server operating system, Microsoft Windows 2000 Advanced Server operating system and Microsoft Windows 2000 Professional operating system are called Windows 2000 for short. Microsoft Windows Vista Business operating system is called Windows Vista for short. Microsoft Windows XP Professional x64 Edition operating system is called Windows XP x64 Edition for short. Microsoft Windows XP Home Edition operating system and Microsoft Windows XP Professional operating system are called Windows XP for short. Microsoft Windows NT Server network operating system version 3.51/4.0 and Microsoft Windows NT Workstation operating system version 3.51/4.0 are called Windows NT for short. Microsoft Windows Millennium Edition Operating System is called Windows Me for short. Microsoft Windows 98 operating system is called Windows 98 for short. Microsoft Windows 95 operating system is called Windows 95 for short. Linux

® is registered trademark of Linus Torvals in Japan and other countries. Red Hat ® and Red Hat Enterprise Linux are registered trademark of Red Hat, inc. in America and other countries.

Names used with sample applications are all fictitious. They are unrelated to any existing product names, names of organizations, or individual names.

AVOCENT and DVC (DAMBRACKAS VIDEO COMPRESSION) are registered trademarks of US AVOCENT in the United States and other countries.

The patent numbers for the DVC technology of AVOCENT US:

US Patent Number: 5,732,212/5,937,176/6,633,905/6,681,250/6,701,380 (other patents pending)

Taiwanese Patent Number: 173784

European Patent Number: 0 740 811

To prevent voltage sag:

This product may be affected by voltage sag caused due to lightning. To prevent voltage sag, you are recommended to use an AC uninterruptible power supply (UPS) unit.

Notes:

- (1) No part of this manual may be reproduced in any form without prior written permission of NEC Corporation.
- (2) The contents of this manual are subject to change without prior notice.
- (3) The contents of this manual shall not be copied or altered without prior written permission of NEC Corporation.
- (4) All efforts have been made to ensure the accuracy of all information in this manual. If you find any part unclear, incorrect, or omitted in this manual, contact the sales agent where you purchased this product.
- (5) NEC assumes no liability arising from the use of this product, nor any liability for incidental or consequential damage arising from the use of this manual regardless of (4) above.

(THIS PAGE IS INTENTIONALLY LEFT BLANK)

PREFACE

Welcome to the NEC Express5800/ft series.

NEC Express5800/ft series is a “fault-tolerant (ft)” server focusing on “high reliability” in terms of fault-tolerance, in addition to “high performance,” “scalability,” and “general versatility” provided by NEC Express5800 series. In the event of trouble, its dual configuration will allow the system to instantaneously isolate the failed parts to assure non-stop running; operation will be moved smoothly from one module to the other, minimizing damage to it. You can use this NEC Express5800/ft series in a mission-critical system where high availability is required. By the use of Linux operating systems, it also provides outstanding openness for general-purpose applications, etc.

To make the best use of these features, read this User's Guide thoroughly to understand how to operate NEC Express5800/ft series.

ABOUT THIS USER'S GUIDE

This User's Guide helps a user to properly setup and use the product.

Consult this guide to ensure safety as well as to cope with trouble during a system setup and daily operation.

Keep this manual handy.

This User's Guide is intended for users who have a good knowledge on the basic use of Linux operating systems and general I/O devices such as a keyboard and mouse.

How to Use This User's Guide

This guide consists of eight chapters and appendices. To help you find a solution quickly, the guide contains the following information:

For descriptions on setting up this product, see the separate volume "User's Guide (Setup)."

Read "Precautions for Use" first.

Before going on to main chapters, be sure to read "Precautions for Use." These precautions are very important for using the product safely.

Chapter 1 Precautions for Use

This chapter describes precautions necessary to use the product safely and properly. Be sure to read this chapter before using the product. It also provides information on user support. It will be helpful when you need maintenance service, support, etc.

Chapter 2 General Description

This chapter describes what you should know about the product: its component names, functions, operating procedures as well as handling of devices and other parts.

Chapter 3 Linux Setup and Operation

This chapter describes setup and operation specific to the product when it is on Linux.

Chapter 4 System Configuration

This chapter describes how to make settings of built-in basic input/output system. It also describes factory-shipped parameters.

Chapter 5 Installing and Using Utilities

This chapter describes features and operating procedures of a standard utility "NEC EXPRESSBUILDER." It also describes procedures to install and operate various software programs contained in its DVD.

Chapter 6 Maintenance

This chapter describes maintenance procedures and use of maintenance tools. If you need to move the product for maintenance purposes, follow the steps provided in this chapter.

Chapter 7 Troubleshooting

If the product does not work properly, see this chapter before deciding that it is a breakdown.

Chapter 8 System Upgrade

This chapter describes procedures to add options and precautions. See also this chapter when you replace failed components.

Appendix A Specifications

This appendix lists specifications of the product.

Appendix B I/O Port Addresses

This appendix lists factory-assigned I/O port addresses.

Additional symbols

The following symbols are used throughout this User's Guide in addition to the caution symbols describe at the beginning.

- | | |
|-------------------|--|
| IMPORTANT: | Important points or instructions to keep in mind when using the server or software |
| CHECK: | Something you need to make sure when using the server of software |
| TIPS: | Helpful information, something useful to know |

About our Web Service

Information on NEC Express5800/ft series including modification modules is also available on our web site, NEC Global Site:

<http://www.nec.com/>

ACCESSORIES

This product is shipped with various accessories. See the packing list to make sure everything is included and check the individual items. If some component is missing or damaged, contact your sales agent.

- Keep the accessories in a safe place. You will need them when you perform setup, addition of options, or replacement of failed components.
- To check NEC EXPRESSBUILDER components, see the attached list.
- Be sure to fill out and mail the software registration card that is attached to your operating system.
- Make backup copies of included floppy disks, if any. Keep the original disks as the master disks; use these copies in operation.
- Improper use of an included floppy disk or DVD may alter your system environment. If you find something unclear, stop using them and contact your sales agent.

CONTENTS

PREFACE.....	I
ABOUT THIS USER'S GUIDE	II
How to Use This User's Guide	ii
Additional symbols	iii
About our Web Service	iii
ACCESSORIES.....	IV
CHAPTER 1	1-1
PRECAUTIONS FOR USE.....	1-1
PRECAUTIONS FOR SAFETY	1-3
General	1-3
During Operation.....	1-9
ABOUT OUR WEB SERVICE.....	1-17
CHAPTER 2	2-1
GENERAL DESCRIPTION.....	2-1
NAMES AND FUNCTIONS OF COMPONENTS.....	2-6
Front View	2-7
Rear View.....	2-9
Optical disk drive	2-11
CPU/IO Module	2-12
Mother Board	2-13
LEDs	2-14
POWER UNIT LED	2-18
BASIC OPERATION	2-19
Installing/removing the front bezel	2-20
Power ON.....	2-21
Power OFF	2-22
POST Check.....	2-22
Floppy Disk Drive (Option)	2-26
DVD-ROM drive.....	2-28
CHAPTER 3	3-1
LINUX SETUP AND OPERATION	3-1
DISK OPERATIONS	3-2
Operable disk configuration	3-2
Replacing a hard disk drive.....	3-4
DUPLEX LAN CONFIGURATION	3-9
Functional overview	3-9
Operable network configuration.....	3-9
Configuring duplication	3-9
CHECKING THE DUPLICATING OPERATION OF MODULES.....	3-12
Evaluate Startup and Stop of PCI Modules	3-12

Confirm Start and Stop of CPU Modules	3-15
ft Server service.....	3-17
Notes on access to USB FDD.....	3-18
Configuring the video mode.....	3-19
CHAPTER 4.....	4-1
SYSTEM CONFIGURATION	4-1
SYSTEM BIOS –SETUP–.....	4-2
Starting SETUP Utility	4-3
Description of On-Screen Items and Key Usage	4-4
Configuration Examples	4-6
Menu and Parameter Descriptions.....	4-8
SAS BIOS – SAS Configuration Utility –.....	4-39
FORCED SHUTDOWN.....	4-43
Forced Shutdown.....	4-43
REMOTE MANAGEMENT FUNCTION	4-44
CHAPTER 5.....	5-1
INSTALLING AND USING UTILITIES	5-1
NEC EXPRESSBUILDER	5-2
Boot Selection Menu	5-2
Autorun Menu	5-4
NEC ESMPRO AGENT AND MANAGER.....	5-5
Overview	5-5
NEC ESMPRO Agent.....	5-13
NEC ESMPRO Manager.....	5-24
Maintenance of NEC Express5800/ft series	5-37
NEC DIANASCOPE.....	5-59
Notes.....	5-59
NEC PRODUCT INFO COLLECTION UTILITY	5-60
CHAPTER 6.....	6-1
MAINTENANCE	6-1
DAILY MAINTENANCE	6-2
Checking Alert.....	6-2
Checking STATUS LEDs	6-2
Making Backup Copies	6-3
Cleaning.....	6-3
SYSTEM DIAGNOSTICS	6-7
Test Items.....	6-7
Startup and Exit of System Diagnostics	6-7
MAINTENANCE TOOLS.....	6-10
Starting the Off-line Maintenance Utility	6-10
Function of Maintenance Tools	6-12
RELOCATING/STORING THE NEC EXPRESS5800/FT SERIES	6-14

CHAPTER 7	7-1
TROUBLESHOOTING	7-1
TO LOCATE THE ERRORS	7-2
Error Messages by LED Indication	7-3
POST Error Messages	7-4
Server Management Application Error Message	7-9
TROUBLESHOOTING	7-10
Problems with NEC Express5800/ft series	7-10
Problems with NEC EXPRESSBUILDER	7-20
Problems with Autorun Menu	7-21
Problems with NEC ESMPRO	7-22
COLLECTING TROUBLE LOGS	7-23
Collection of System Information	7-23
COLLECTING THE MEMORY DUMP	7-24
CHAPTER 8	8-1
SYSTEM UPGRADE	8-1
SAFETY PRECAUTIONS	8-2
ANTI-STATIC MEASURES	8-3
PRE-UPGRADE VERIFICATION	8-4
PREPARING YOUR SYSTEM FOR UPGRADE	8-5
2.5-INCH HARD DISK DRIVE	8-6
Installing 2.5-inch Hard Disk Drive	8-7
Removing 2.5-inch Hard Disk Drive	8-9
Replacing 2.5-inch Hard Disk Drive	8-10
CPU/IO MODULE	8-11
Precautions	8-11
Removing CPU/IO Module	8-12
Installing CPU/IO Module	8-15
DIMM	8-17
Precautions	8-18
Installing DIMM	8-19
Removing DIMM	8-22
Replacing DIMM	8-24
PROCESSOR (CPU)	8-25
Installing CPU	8-26
Removing CPU	8-29
PCI BOARD	8-30
Installing PCI Board	8-33
Removing PCI Board	8-38
Replacing PCI Board	8-38
Setup of Optional PCI Board	8-39
APPENDIX A	A-1
SPECIFICATIONS	A-1

(THIS PAGE IS INTENTIONALLY LEFT BLANK)

Chapter 1

Precautions for Use

This chapter includes information necessary for proper and safe operation of the server.

WARNING LABELS

Warning label is placed in the certain part of the system so that the user stays alert to possible risks. Do not remove or damage the label.

If this label is missing, about to peel off, or illegible, contact your sales agent.

The figures below show the location of this label on the server.

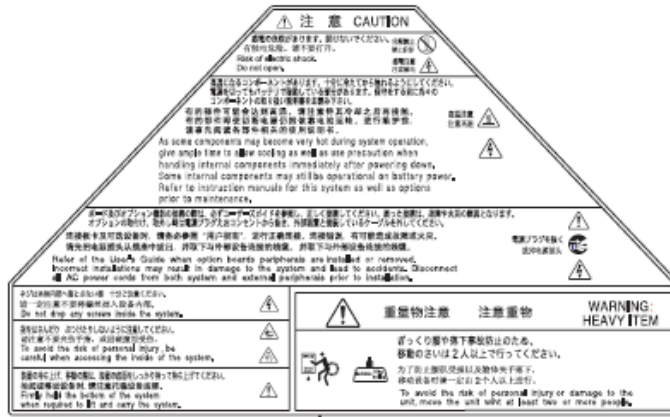

Front of Device

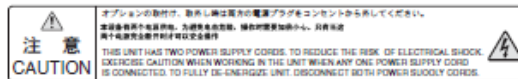











Back of Device

PRECAUTIONS FOR SAFETY

This section provides precautions for using the server safely. Read this section carefully to ensure proper and safe use of the server. For symbol meanings, see "SAFETY INDICATIONS" described in the previous section.

General

 WARNING	
	<p>Do not use the equipment in an operation where human lives are involved or high reliability is required.</p> <p>This equipment is not intended for use and control in facilities/systems where human lives are involved or high reliability is required, including medical devices, nuclear facilities, aerospace equipments, transportation facilities or traffic control facilities. NEC assumes no liability for any accidents or damage to physical assets resulting from the use of this equipment in such systems or facilities.</p>
  	<p>Do not continue to use the equipment if you detect smoke, odor, or noise.</p> <p>If the equipment emits smoke, odor, or noise, immediately flip off the POWER switch, unplug the cord, and contact your sales agent. There is a risk of a fire if you continue to use the equipment.</p>
 	<p>Do not insert a wire or metal object.</p> <p>Do not insert a wire or metal objects into a vent or disk drive slot. There is a risk of an electric shock.</p>

 CAUTION	
  	<p>Prevent water or foreign objects from getting into the equipment.</p> <p>Do not let water or foreign objects (e.g., pins or paper clips) enter the equipment. There is a risk of a fire, electric shock, and breakdown. When such things accidentally enter the equipment, immediately turn off the power and unplug the cord. Contact your sales agent without trying to disassemble it yourself.</p>

Use of Power Supply and Power Cord

⚠ WARNING



Do not handle a power plug with a wet hand.

Do not plug/unplug a power cord with a wet hand.
There is a risk of an electric shock.



Do not connect the ground wire to a gas pipe.

Never connect the ground wire to a gas pipe.
There is a risk of a gas explosion.

⚠ CAUTION



Do not plug the attached cord in a nonconforming outlet.

Use a wall outlet with specified voltage and power type.
There is a risk of a fire or electricity leakage if you use a nonconforming outlet.
Avoid installing the equipment where you may need an extension cord. If the cord that does not meet the power specifications, there is a risk of overheating that could lead to a fire.



Do not plug multiple cords in a single outlet.

If the rated current exceeds the rating, there is a risk of overheating that could lead to a fire.



Do not plug the cord insecurely.

Insert the plug firmly into an outlet. There is a risk of heat or fire due to poor contact when you insert the plug insecurely. If dust settles on the slots and it absorbs moisture, there is also a risk of heat or fire.

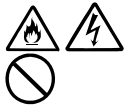

Do not use nonconforming power cords.

Do not use any AC cord other than the enclosed one. There is a risk of fire when the current exceeds the rating on the cord.
You also have to observe the following prohibitions about handling and connecting interface cables.

- Do not pull on the cord.
- Do not pinch the cord.
- Do not bend the cord.
- Keep chemicals away from the cord.
- Do not twist the cord.
- Do not place any object on the cord.
- Do not use cords as bundled.
- Do not alter, modify, or repair the cord.
- Do not staple the cord.
- Do not use any damaged cord. (Replace it with a new one of the same specifications. For replacement procedures, contact your sales agent.)

⚠ CAUTION



Do not use any power outlet other than one for 3-prong.



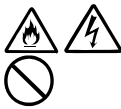

This equipment has a 3-prong plug attached. You can only plug-in to a 3-prong outlet. If you plug in to any outlets other than the 3-prong one, you may get electric shock.







Do not use the enclosed power cord for other devices or purposes.

The attached power cord is specifically designed for use in connecting to this equipment and its safety is confirmed. Do not use the power cord to other devices. Doing so may result in fire or electric shock.

Installation, Relocation, Storage and Connection

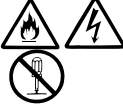
⚠ CAUTION	
	<p>Do not install or store the equipment in an unsuitable place.</p> <p>Install or store the equipment in such a place as specified in this User's Guide. There is a risk of a fire if you place the server in a place such as follows.</p> <ul style="list-style-type: none">■ a dusty place■ a humid place located near a boiler, etc■ a place exposed to direct sunlight■ an unstable place
	<p>Do not use or store this product under corrosive gas environment.</p> <p>Avoid the usage or storage of this product in an environment which may be exposed to corrosive gases, such as those including but not limited to: sulfur dioxide, hydrogen sulfide, nitrogen dioxide, chlorine, ammonia and/or ozone.</p> <p>Avoid installing this product in a dusty environment or one that may be exposed to corrosive materials such as sodium chloride and/or sulfur.</p> <p>Avoid installing this product in an environment which may have excessive metal flakes or conductive particles in the air.</p> <p>Such environments may cause corrosion or short circuits of the printed board within this product, resulting in not only damage to this product, but may even lead to be a fire hazard.</p> <p>If there are any concerns regarding the environment at the planned site of installation or storage, please contact your sales agent.</p>
	<p>Do not use any non-designated interface cable.</p> <p>Use only interface cables designated by NEC; identify which component or connector to attach beforehand. If you use an inappropriate cable or make a wrong connection, there is a risk of short-circuit that could lead to a fire.</p> <p>You also have to observe the following prohibitions about handling and connecting interface cables:</p> <ul style="list-style-type: none">■ Do not use any damaged cable connector.■ Do not step on the cable.■ Do not place any object on the cable.■ Do not use the equipment with loose cable connections.■ Do not use any damaged cable.
	<p>Do not disable the lock mechanism</p> <p>Do not use this product with the lock mechanism being removed or disabled. Doing so may cause personal injury if this product drops.</p>

Cleaning and Handling of Internal Devices

 WARNING	
	<p>Do not disassemble, repair, or alter the server.</p> <p>Unless described herein, never attempt to disassemble, repair, or alter the equipment. There is a risk of an electric shock or fire as well as malfunction.</p>
	<p>Do not look into the optical disk drive.</p> <p>The optical disk drive uses a laser beam. Do not look or insert a mirror inside while the system is on. A laser beam is invisible; if your eyes are exposed to the laser beam, there is a risk of losing eyesight.</p>
	<p>Do not detach a lithium battery yourself.</p> <p>This equipment has a lithium battery. Do not detach it yourself. If the battery is exposed to fire or water, it could explode.</p> <p>When the equipment does not work correctly because of lithium battery life, contact your sales agent. Do not disassemble replace or recharge the battery yourself.</p>
	<p>Caution for electric shock</p> <p>You can replace internal, optional devices while the equipment is powered-on. However, carefully follow the instructions on this guide when you do so. If you touch the internal devices other than the ones described in this guide, there is a risk of electrical shock.</p> <p>Make sure to power off the equipment and disconnect the power plug from a power outlet before cleaning or installing/removing internal optional devices. Touching any internal device of the equipment with its power cord connected to a power source may cause an electric shock even if the server is off-powered.</p> <p>Disconnect the power plug from the outlet occasionally and clean the plug with a dry cloth. Heat will be generated if condensation is formed on a dusty plug, which may cause a fire.</p>

⚠ CAUTION



High temperature

Immediately after powering off the system, system components such as hard disk drive may be very hot. Wait for the server to cool down completely before adding/removing components.



Make sure to complete installation.

Firmly install all power cords, interface cables and/or boards. An incompletely installed component may cause a contact failure, resulting in fire and/or smoke.

















Protect the unused connectors with the protective cap.



The unused power cord connectors are covered with the protective cap to prevent short circuits and electrical hazards. Attach the protective cap to the unused connector. Failure to follow this warning may cause a fire or an electric shock.

During Operation

 CAUTION	
  	Keep animals away. Animal's waste or hair may get inside the equipment to cause a fire or electric shock.
  	Do not place any object on top of the server. The object may fall off to cause injuries, damage to hardware and/or a fire.
  	Do not leave the optical disk drive's tray ejected. Dust may get in the equipment to cause malfunction. The ejected tray may also become a cause of injuries.
   	Do not touch the equipment when it thunders. Unplug the equipment when it threatens to thunder. If it starts to thunder before you unplug the equipment, do not touch the equipment and cables. There is a risk of a fire or electric shock.

Rack-mount Model

 **WARNING**



Do not install the equipment on a nonconforming rack.

Install the equipment on a 19-inch rack conforming to the EIA standard. Do not use the equipment without a rack or install it on a nonconforming rack. The equipment may not function properly, and there is a risk of damage to physical assets or injuries. For suitable racks, contact your sales agent.



Do not use in the spot other than the designated one.

Install this equipment in the spot where it satisfies the conditions of installation. Installing this equipment in an undesirable spot causes negative effects on the equipment itself and other systems. There is also a risk of a fire as well as an injury caused by the rack that falls. Refer to the description that is attached the rack, or contact your maintenance service agent for the detailed accounts of the installation spot or a seismic construction.

⚠ CAUTION

Be careful not to hurt your fingers.

Exercise great care not to hurt your fingers on the rail when you mount/dismount the server into/from the rack.



Do not attempt to install the server yourself.

Transport and install the rack with three and more people. Doing so with two people and less could cause the falling of the rack and damaging the surroundings. Make sure to support a rack, transport and install it particularly when it is a high one (such as 44U rack) that is not anchored with stabilizers.



Do not install the equipment in such a manner that its weight is imposed on a single place.

To distribute the weight, attach stabilizers or install two or more racks. It may fall down to cause injuries.



Do not assemble parts alone. Check the hinges and gudgeons.

Mount doors and trays to a rack with two and more people. Make sure that the hinges and gudgeons on the top and the bottom of the door when you install it. Neglecting this check could lead to dropping some parts and cause a breakage of them or could result in injuries.



Do not pull a equipment out of the rack if it is unstable.

Before pulling out a equipment, make sure that the rack is fixed (by stabilizers or quake-resistant engineering). It may fall down to cause injuries.



Do not leave two or more equipments pulled out from the rack.

If you pull out two or more equipments, it may fall down to cause injuries. You can only pull out one device at a time.



Do not install excessive wiring.

To prevent burns, fires, and damage to the equipment, make sure that the rated load of the power branch circuit is not exceeded. For more information on installation and wiring of power-related facilities, contact your electrician or local power company.



Do not pull out a equipment from the rack during operation.

Do not pull out a equipment while it works. There is a risk of malfunction and injuries.

For Proper Operation

Observe the following instructions for successful operation of the server. Failure to observe them could lead to malfunction or breakdown.

- Do not use a cellular phone or pager around the equipment. Turn off your cellular phone or pager when you use the equipment. Their radio waves may cause the equipment to malfunction.
- Perform installation in a place where the system can operate correctly. For details, see the separate volume “User’s Guide (Setup).”
- Before turning off the power or ejecting a disk, make sure that the access LED is off.
- When you have just turned off the power, wait at least 30 seconds before turning it on again.
- Once you have turned on the server, do not turn it off until the “NEC” logo appears on the screen.
- After plugging in the power cord, do not turn on the power of the equipment for 30 seconds.
- For safe operation, it is recommended to reboot the OS after duplication is completed.
- Before you move the equipment, turn off the power and unplug the cord.
- This server shall not assure reproduction of copy-protect CDs using reproduction equipment if such disks do not comply with CD standards.
- Clean the equipment regularly. (For procedures, see Chapter 6.) Regular cleaning is effective in preventing various types of trouble.
- Lightning may cause voltage sag. As a preventive measure, it is recommended to use UPS (uninterruptible power supply).

This equipment does not support the connection through an UPS serial port (RS-232C) or the control using PowerChute *Plus*.

- Check and adjust the system clock before operation in the following conditions:
 - After transporting the equipment
 - After storing the equipment
 - After the equipment halt under the conditions which is out of the guranteed environment conditions (Temperature: 10 to 35°C, Humidity: 20 to 80%).

Check the system clock once in a month. It is recommended to operate the system clock using a time server (NTP server) if it is installed on the system which requires high level of time accuracy. If the system clock goes out of alignment remarkably as time goes by, though the system clock adjustment is performed, contact your sales agent.

- When you store the equipment, keep it under storage environment conditions (Temperature: -10 to 55°C, Humidity: 20 to 80%, non-condensing).

- If NEC Express5800/ft series, the built-in optional devices, and the media set for the backup devices (tape cartridges) are moved from a cold place to a warm place in a short time, condensation will occur and cause malfunctions and breakdown when these are used in such state. In order to protect important stored data and assets, make sure to wait for a sufficient period of time to use the server or components in the operating environment.

Reference: Length of the time effective at avoiding condensation in winter (more than 10°C differences between room temperature and atmospheric temperature)

Disk devices: Approximately 2-3 hours

Tape media: Approximately 1 day

- Make sure that the optional devices are attachable and connectable to the equipment. There is a risk of malfunctions that could lead to a breakdown of the equipment even if you could attach and connect.
- Make sure that your options are compatible with the system. If you attach any incompatible option, there is a risk of malfunction that could lead to a breakdown.
- It is recommended to use NEC's genuine option products. Some competitors' products are compatible with this server. However, servicing for trouble or damage resulting from such a product will be charged even within the warranty period.

■ Transferring to Third Party

Observe the following notes for transferring the main unit or other embedded devices to third party.

■ Main unit

Attach this manual when you alienate or sell this device.

IMPORTANT:

Data in the hard disk drives:

Make sure to delete all the important data such as client information or corporate accounting information stored in the hard disk drives installed on the device to be alienated.

Operations such as Empty Recycle Bin on Windows or Linux, or commands such as formatting seem to delete data completely. However, the data still remains on the hard disk drives. Such undeleted data can be restored by special software, and may be diverted.

To avoid this kind of troubles, it is strongly recommended to use commercial software or services to completely delete the data. For the details on data deletion, contact your local reseller.

We are not responsible for any data leakage from alienating or selling the device if you do not delete the data completely.

■ Bundled software

The following conditions must be satisfied when you alienate or sell the bundled software.

- Alienate all the bundled. After alienating, do not save any copy of them.
- Alienation or transferring of Software User License Agreement must be satisfied.
- For software that alienation or transferring is not allowed, uninstall from the device before alienate it.

Disposal of Equipment and Consumables

- When you dispose of the main unit, hard disk drives, floppy disks, DVDs, optional boards, etc., you need to observe your local disposal rules. Dispose the attached power cable along with the equipment to avoid being used with other equipment.

For details, ask your municipal office.

IMPORTANT:

For disposal (or replacement) of batteries on the motherboard, consult with your sales agent.

You are responsible for wiping out such data before disposal. Erase all data on the hard disk, backup data cartridges, floppy disks, or other writable media (such as CD-R and CD-RW); prevent your data from being restored and reused by a 3rd party. You need to exercise sufficient care to protect privacy and confidential information.

- Some of the system components have limited lifetime (e.g., cooling fans, built-in batteries, built-in DVD-ROM drive, floppy disk drive and mouse). For stable operation, it is recommended to replace them regularly. For lifetime of individual components and replacing procedures, ask your sales agent.

Transporting Device

This unit and options use lithium-metal battery or lithium-ion battery.
Contact your local reseller for transporting the unit by air or shipping since the regulation is applied to air and maritime transportation of lithium battery

ABOUT OUR WEB SERVICE

Information on NEC Express5800/ft series including modification modules is also available on our web site, NEC Express5800 Web Site Asia Pacific, at <http://www.nec.co.jp/express/index.html>

Advice for Your Health

Prolonged use of a computer may affect your health. Keep in mind the following to reduce stresses on your body:

Sit in a good posture

Sit on your chair with your back straight. If the desk height is appropriate, you will slightly look down at the screen and your forearms will be parallel to the floor. This “good” work posture can minimize muscle tension caused by sedentary work.

If you sit in a “bad” posture—for example, sit round-shouldered or with your face too close to the display—you may easily suffer fatigue or have your eyesight affected.



Adjust the installation angle of Display

Most types of displays allow you to adjust the angle vertically and horizontally. This adjustment is very important to prevent the reflection of light as well as to make the screen more comfortable to see. Without this adjustment, it is difficult to maintain a “good” work posture and may get tired soon. Be sure to adjust the angle before using the display.

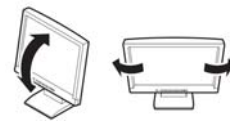

Adjust Brightness and Contrast

Displays allow you to adjust brightness and contrast. Optimum brightness and contrast vary depending on the individual, age, brightness of the room, etc; you need to make an adjustment accordingly. If the screen is too bright or too dark, it is bad for your eyes.

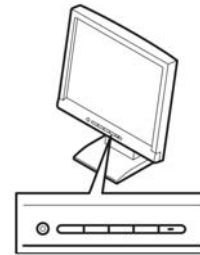

Adjust the installation angle of Keyboard

Some types of keyboards allow you to adjust the angle. If you adjust the angle to make the keyboard more comfortable to use, you can greatly reduce stresses on your shoulders, arms, and fingers.

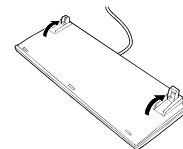
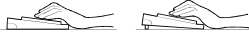

Clean the Equipment

Cleanliness of the equipment is very important not only for reasons of appearance but also from the viewpoints of function and safety. Especially, you need to regularly clean the display, which gets unclear due to the accumulation of dirt.

Take a break when you get tired

If you feel tired, you are recommended to refresh yourself by taking a short break or doing a light exercise.



Chapter 2

General Description

This chapter describes what you need to know to use the NEC Express5800/ft series. Refer to this chapter when you want to know about certain components and how to operate them.

STANDARD FEATURES

The NEC Express5800/ft series is the server that has hardware for two servers.

High performance

- Intel® Xeon® Processor (2.00GHz/2.93GHz)
- High-speed Ethernet interface (1000Mbps/100Mbps/10Mbps supported)
- High-speed disk access (SAS (Serial Attached SCSI))

Expandability

- Various IO optional slots
 - PCI Express REV1.1 (4 lane) 2 slots (Low Profile)
 - PCI Wxpress REV2.0(4 lane)* 2 slots (Full Height)
- Large capacity memory supported : Max 96 GB
- USB supported

High-reliability

- Memory monitoring feature (Correctable error correction/ Uncorrectable error detection)
- Bus parity error detection
- Error notification
- BIOS password feature

Management Utilities

- NEC ESMPRO

Ready-to-use

- Quick cableless connection: hard disk, CPU/IO module

Fault-tolerant Feature

- Redundant modules achieved within a system
- Higher hardware availability by isolation of failed module

Various Features

- Graphic accelerator "PILOT2" supported

Self-diagnosis

- Power On Self-Test (POST)
- Test and Diagnosis (T&D) Utility

Maintainability

- Off-line Maintenance Utility

Easy and Fine Setup

- NEC EXPRESSBUILDER (system setup utility)
- SETUP (BIOS setup utility)

* For R320a-M4 only.

Hardware modules work while synchronizing and comparing with each other. Even if one hardware module stops, the server can continue its operation as the service with the other hardware module.

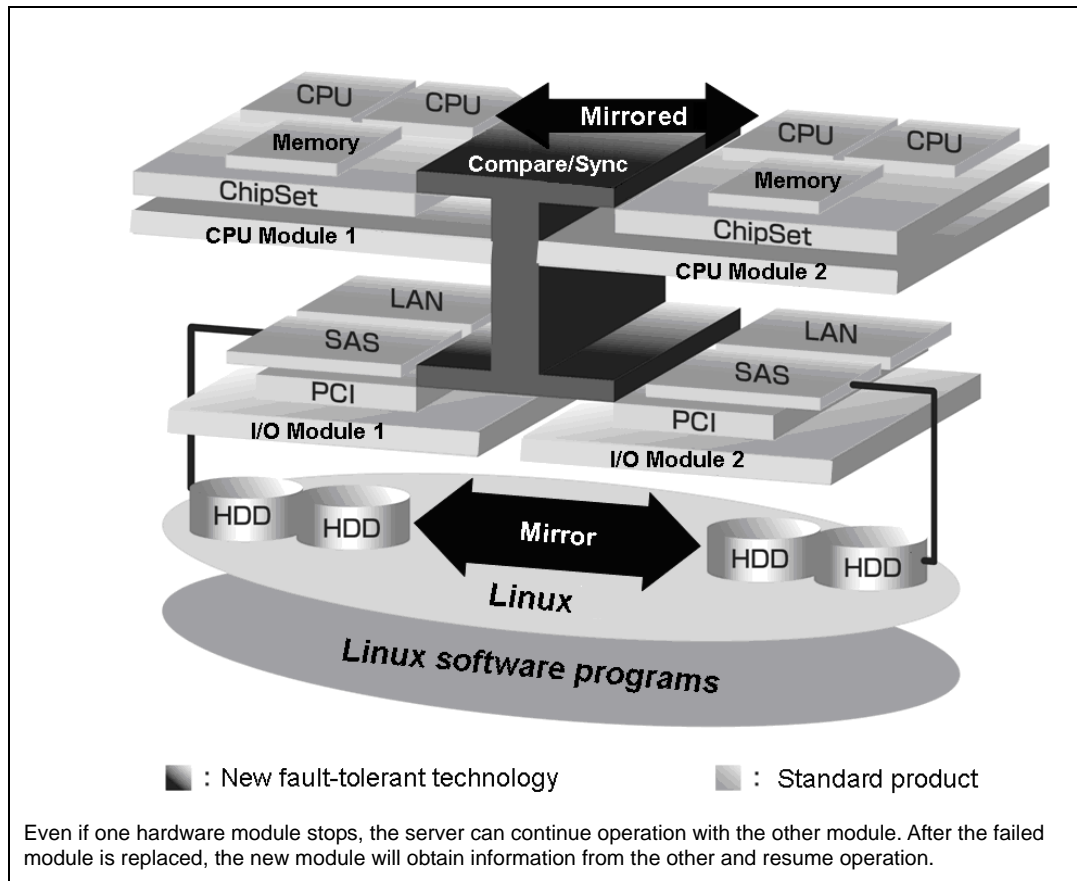

NEC Express5800/ft series is a highly fault-tolerant server that achieves continuous computing operations, data storage mirror, and continuous network connection. It allows you to run Linux Server-based applications.

NEC Express5800/ft series achieves continuous computing operations for the Linux server and server-based applications with its redundant CPU processing and redundant memory. It assures data redundancy through duplication of server data on an independent storage system. These features eliminate server downtime that is usually caused by network disconnection or trouble with the I/O controller, Ethernet adapter or disk drive, and support operation of the network and server applications continuously. While being transparent to application software, NEC Express5800/ft series achieves high fault-tolerance.

NEC Express5800/ft series detects status changes, errors and other events and notifies the Log of these events. If you use an alarm notification tool, you can configure NEC Express5800/ft series to notify you when certain events occur.

NEC ESMPRO is installed on the system as a server management solution. NEC ESMPRO, a GUI-based management tool, allows you to monitor, view, and configure NEC Express5800/ft series. This tool also supports both local and remote management of NEC Express5800/ft series.

NEC Express5800/ft series mainly provides the following advantages:

- **Highly fault-tolerant processing and I/O subsystems**

NEC Express5800/ft series use redundant hardware and software to assure server operation even if one module suffers trouble with its processor, memory, I/O (including trouble related to the I/O controller), disk drive, or Ethernet adapter.
- **Continuous network connection**

NEC Express5800/ft series maintains continuous network connection by detecting any trouble with the network adapter, connection, etc. If trouble occurs, the standby network connection will take over all network traffic processing and thus securely maintain the network system connection of NEC Express5800/ft series without losing network traffic or client connection.
- **Support of multiple network connections**

Since NEC Express5800/ft series can support multiple Ethernet connections, you can add network redundant control or network traffic control.
- **Industry standard hardware platform**

NEC Express5800/ft series uses IA (Intel Architecture)-based system hardware.
- **No need to modify applications**

You can run Linux-compliant applications on NEC Express5800/ft series. Thus, unlike other highly fault-tolerant products, special API or scripts are not necessary.
- **Automatic mirroring**

NEC Express5800/ft series automatically maintains data as the current data.
- **Automatic detection and notification of faults**

NEC Express5800/ft series detects and sorts out all events such as general status changes and faults, and notifies Log of these events.
- **Transparent migration**

NEC Express5800/ft series constantly monitors events. If trouble occurs on NEC Express5800/ft series' server module, it will transparently use a redundant module of the failed module. This feature maintains data and user access without losing application service.
- **Automatic reconfiguration**

When the failed module restarts after the trouble is corrected, NEC Express5800/ft series will perform reconfiguration automatically, and if necessary, resynchronize the affected modules. Reconfiguration can include CPU processing (e.g., CPU memory), server's operating system (and related applications), and system data stored on the hard disks. In most cases, NEC Express5800/ft series automatically restores redundancy of the server modules after recovery.

- Local and remote management

NEC Express5800/ft series uses NEC ESMPRO as a server management tool. This tool uses a GUI that enables monitoring and setting of NEC Express5800/ft series. NEC ESMPRO can be used both locally and remotely on work station PCs or server PCs.

- Event notification function

When trouble or other events are detected on NEC Express5800/ft series, they will be notified to Log and saved. Therefore, you can view the log items locally or remotely by a usual Linux procedure. Since an NEC Express5800/ft series events use unique IDs, they are easy to distinguish.

- In-service repairing

You can repair or replace a failed module even if NEC Express5800/ft series is operating.

- Partition structure

On this server model, the first logical drive will be the following state when the setup by NEC EXPRESSBUILDER is complete.

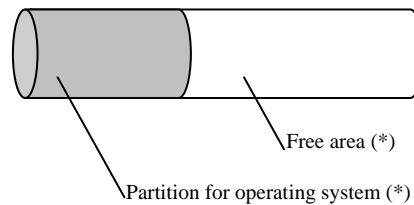

* The size varies depending on the specification at setup.

CHECK:

The partition for operating system is not mirrored at the time of NEC EXPRESSBUILDER setup completion. Mirror the partition separately.

- Linux OS and media

The Linux OS media used on NEC Express5800/ft series are not specifically processed for it. The standard operating methods of Linux are same as general.

NAMES AND FUNCTIONS OF COMPONENTS

Names and functions of components are shown below:

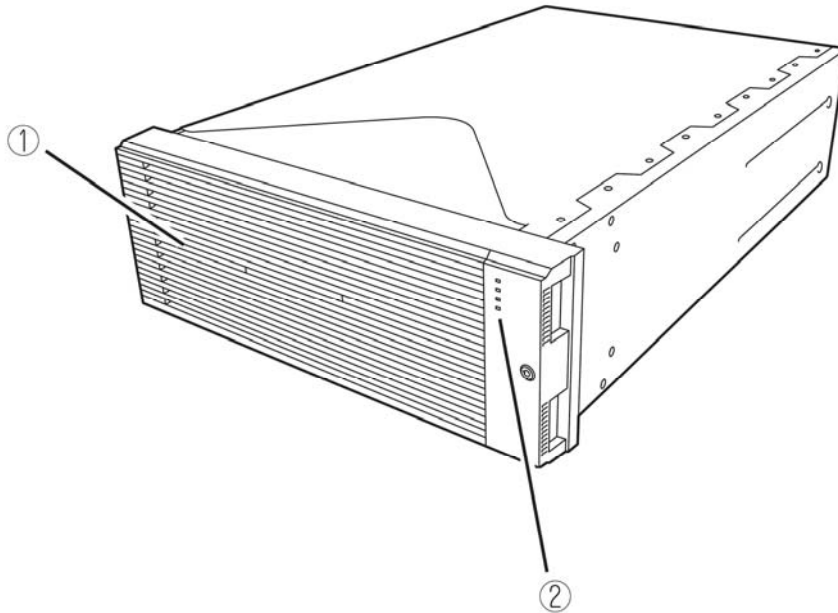

- (1) **Front bezel**
The cover to protect devices in the front.

- (2) **LEDs**
For more information, see the description on the front view on page 2-8 and rear view on page 2-10.

Front View

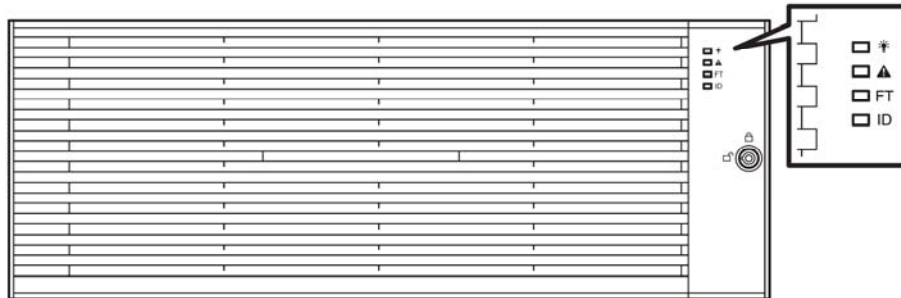

With front bezel attached

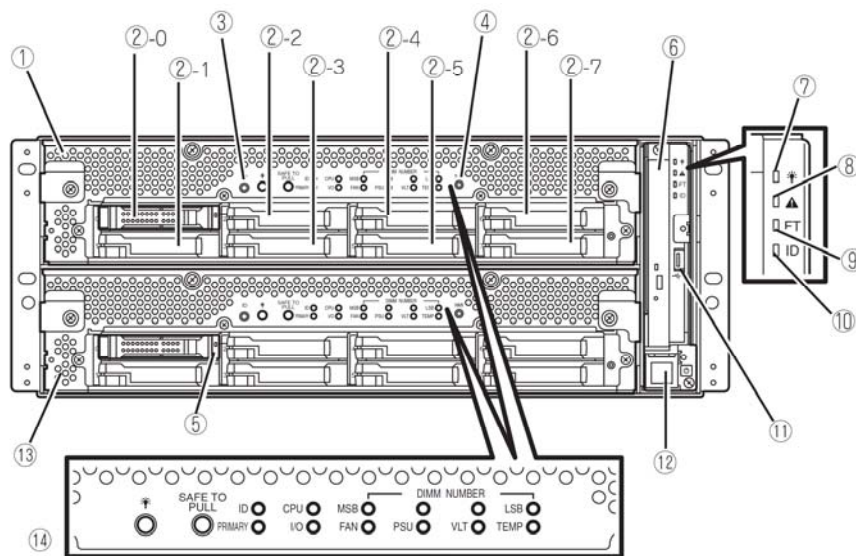

With front bezel removed

- (1) **CPU/I/O module 0**
This is a module with a set of CPU (processor), memory (DIMM), PCI board, cooling fan unit, and hard disk drive.
- (2) **Hard disk drive bay**
This is the bay to mount the hard disk drive. The number after the numbers in parentheses indicates a slot number.
- (3) **UID (Unit ID) switch**
This is to switch ON/OFF the UID LED on the front of the device. When processing the switch once, UID LED lights and it goes off when pressing it again.
- (4) **Dump (NMI) switch**
Memory dump is executed when pressing the button.

- (5) Disk access LED**
This LED illuminates while accessing the installed DVDs or CD-ROMs.
- (6) Optical disk drive**
This device is used to read data from the disks such as DVDs and CD-ROMs (see page 2-29).
- (7) System POWER LED**
This illuminates in green when one of the powers of the CPU/IO modules is ON. LED goes off when both powers of CPU/IO module are OFF.
- (8) System FAULT LED**
When one of the CPU/IO modules has an error, the LED illuminates in amber. Details can be confirmed by checking EXPRESSSCOPE. The LED illuminates in amber when it cannot identify which one of the CPU/IO moulds has an error.
- (9) System FT LED**
This LED displays the device status. The LED illuminates in green when operating under duplex condition. The LED goes off if it's not duplex. The LED illuminates in green when executing Active Upgrade.
- (10) System ID LED**
The system ID LED illuminates in blue on the front bezel if pressing UID switch when there are multiple devices installed on one rack. This enables to identify the device to be maintained. This LED blinks in blue when there are device identification requests remotely.
- (11) USB connector**
It connects with the device supporting USB interface.
- (12) Power switch**
This switch is to turn ON/OFF the power. When pressing it once, the power will be ON. When pressing it again, the power will be OFF. Forced shut down takes place when pressing it for 4 seconds or longer.
- (13) CPU/IO module 1**
This is a module with a set of CPU (processor), memory (DIMM), PCI board, cooling fan unit, and hard disk drive. The name of each part is the same as CPU/IO module 0.
- (14) EXPRESSSCOPE various LEDs (green/amber)**
This LED indicates the status of CPU/IO modules (see page 2-17).

Rear View

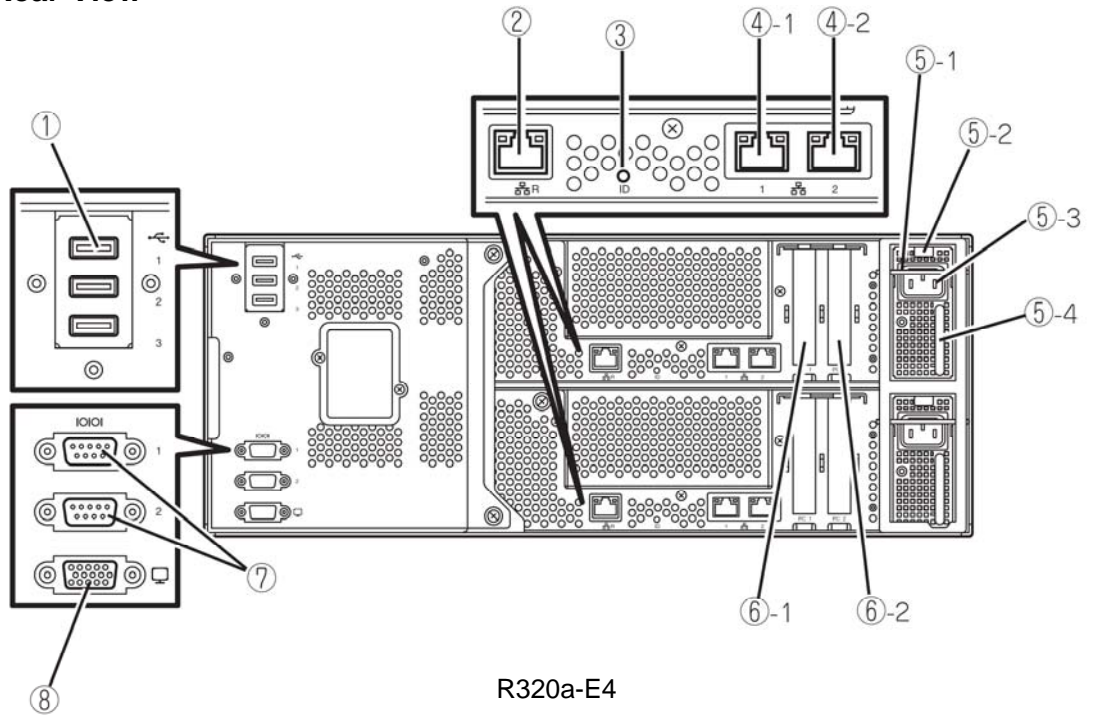

R320a-E4

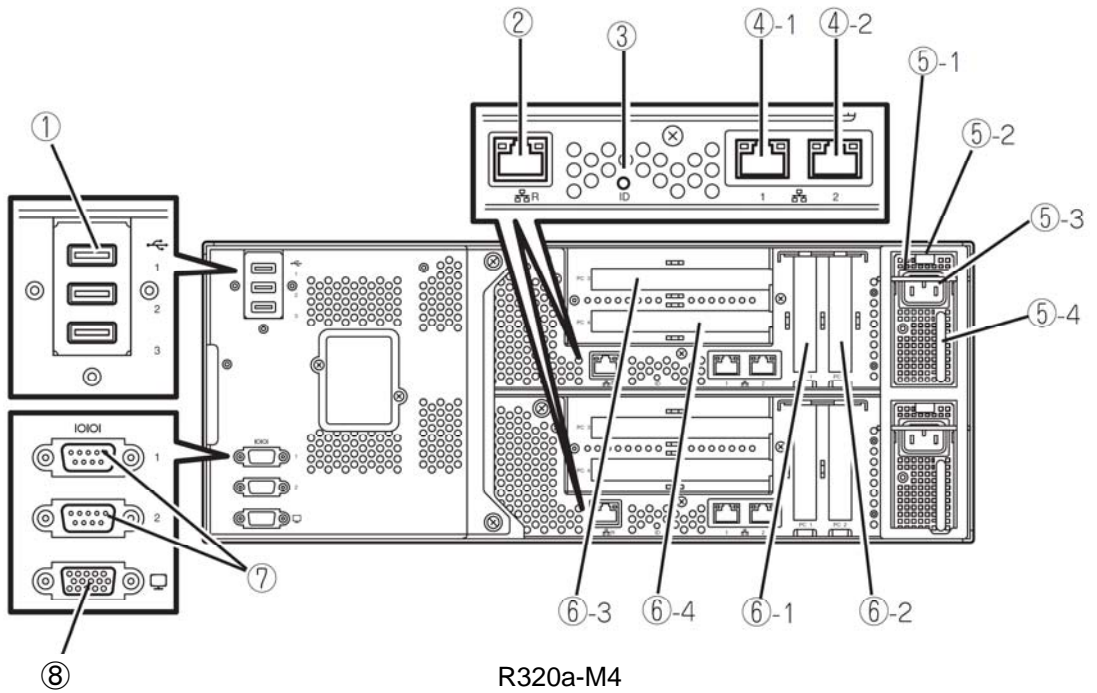

R320a-M4

- (1) USB connector (3 ports)**
This connects with the device supporting USB interface.
- (2) Management port**
Ethernet connector supporting 100BASE-TX/10BASE-T.
- (3) Module ID(ID LED)**
The Module ID LED illuminates in green on side of CPUIO module in back if pressing UID switch when there are multiple devices installed on one rack. This enables to identify the device to be maintained. This LED blinks in green when there are device identification requests remotely.
- (4) LAN connector**
This is the connector supporting 1000BASE-T/100BASE-TX/10BASE-T. It connects with the network system on LAN. The number "1" indicates LAN 1 and "2" indicates LAN 2 after the circled numbers.
- (5) Power unit**
This is a power unit, a standard equipment.

 - (5)-1 Stopper**
This is a lever for the CPU/IO module not to be disconnected with the power code connected. Ensure that the bar is not unset to remove CPU/IO module.
 - (5)-2 Ejector**
 - (5)-3 AC inlet connector**
This is a socket to connect power code. Connect power code to the inlet of CPU/IO module first which is desired to be primary.
 - (5)-4 Handle**
- (6) PCI slot**
This is a slot to mount an optional PCI board (see page 8-30). The number after the circled numbers indicates a slot number.
- (7) Serial Port for maintenance(COM)**
Do not use this port. Maintenance personnel only.
- (8) Monitor connector**
This is a connector to connect with a display device.

Optical disk drive

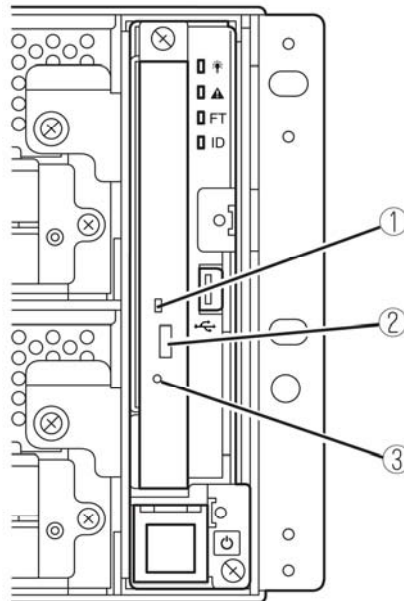

- (1) **Status LED**
The LED that lights while accessing the loaded DVD/CD-ROM
- (2) **Tray eject button**
The button to eject the tray.
- (3) **Manual release**
The system ID LED illuminates in green on the front bezel if pressing UID switch when there are multiple devices installed on one rack. This enables to identify the device to be maintained. This LED blinks in blue when there are device identification requests remotely.

CPU/IO Module

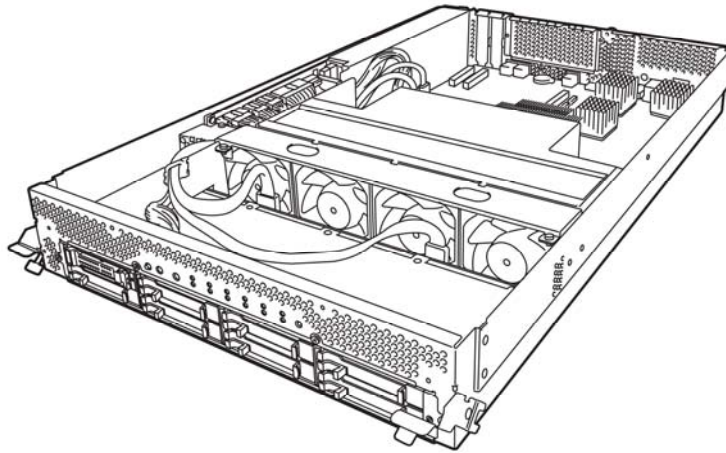

R320a-E4 (top cover removed)

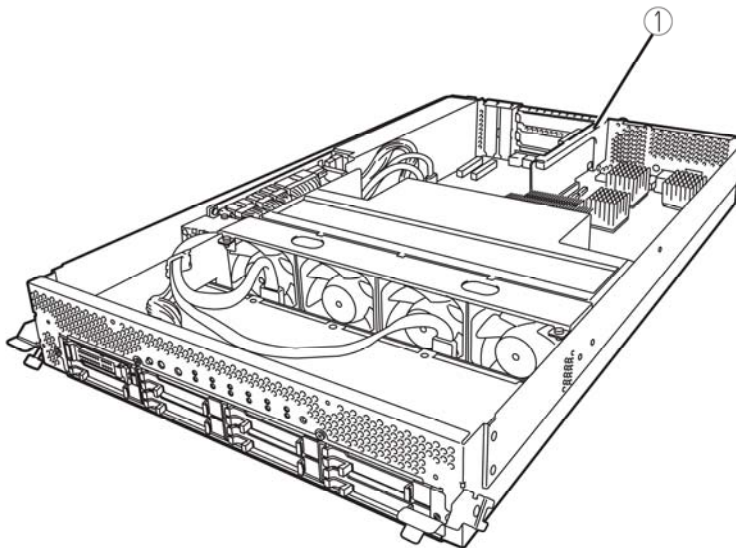

R320a-M4 (top cover removed)

(1) PCI Riser card

Mother Board

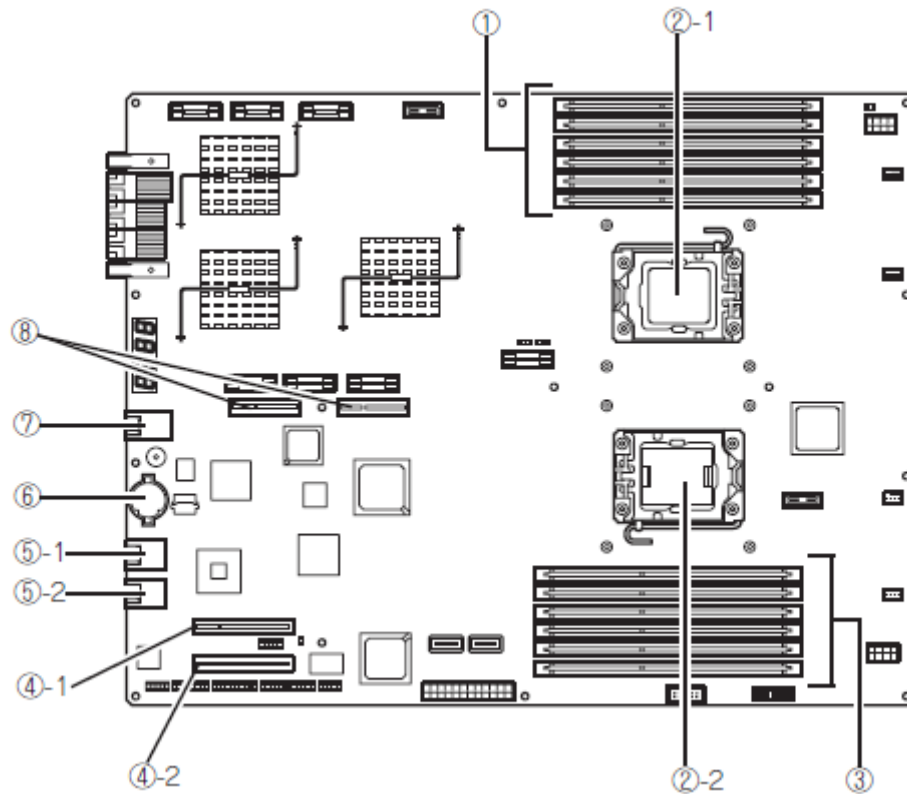

CPU/I/O module mother board

- | | |
|---|--|
| <p>(1) DIMM slot
DIMM 1 – DIMM6 from the top.</p> <p>(2) Processor(CPU) socket
(2)-1 Processor #1(CPU#1)
(2)-2 Processor #2(CPU#2)</p> <p>(3) DIMM slot
DIMM7 – DIMM12 from the bottom.</p> <p>(4) Connector for PCI card
(4)-1 PCI slot #1
(4)-2 PCI slot #2</p> | <p>(5) LAN connector
(5)-1 LAN1
(5)-2 LAN2</p> <p>(6) Lithium battery</p> <p>(7) Management port</p> <p>(8) Connector for PCI riser card
Used for R320a-M4 model only.</p> |
|---|--|

LEDs

System POWER LED

When one of the power of CPU/IP modules is ON, the LED illuminates in green. The LED goes off when both powers of CPU/IO module are OFF.

System FAULT LED

When one of the CPU/IO modules has an error, the LED illuminates in amber. Details can be confirmed by checking EXPRESSSCOPE. The LED illuminates in amber when it cannot identify which one of the CPU/IO modules has an error.

System FT LED

This LED displays the device status. The LED illuminates in green when operating under duplex condition. The LED goes off if it's not duplex. The LED illuminates in green when executing Active Upgrade.

System ID LED

The system ID LED illuminates in blue on the front bezel if pressing UID switch when there are multiple devices installed on one rack. This enables to identify the device to be maintained. This LED blinks in blue when there are device identification requests remotely.

Hard Disk Drive LED

Hard Disk LED	Description	Action
Not on	The disk is in the idle state.	
Green	Accessing the disk	
Amber	Disk failure	Contact a maintenance service company.
Blinking in amber (Illuminate in green when accessing the disk)	The mirror of the disk is disconnected.	Perform mirroring.
Blinking in green and amber in turn	The hard disk drive configuration (rebuild) is on going.	Wait for a while; the LED blinks in green after rebuild finishes. If the rebuild fails, the LED illuminates in amber.

Access LED on the DVD-ROM drive

This LED illuminates when the installed DVD or CD-ROM is being accessed.

LAN Connector LED

- LINK/ACT LED

The LINK/ACT LED shows the status of a standard network port. It is green if power is supplied to the main unit and hub, and they are connected correctly ("LINK"). It blinks green while the network port sends or receives data (ACT).

When the LED does not illuminate during "LINK," check the condition and connection of network cables. If there is nothing wrong with the cables, a defect is suspected in the network (LAN) controller. In this case, contact your sales agent.

- Speed LED

This LED indicates the network interface of the communication mode used by a network port.

1000BASE-T and 100BASE-TX are the supported LAN port types. When this LED illuminates in amber, the port is operating on 1000BASE-T; when in green, 100BASE-TX; and when not illuminate, 10BASE-T.

EXPRESSSCOPE

Corresponding EXPRESSSCOPE LEDs (amber) illuminate when modules have failures.

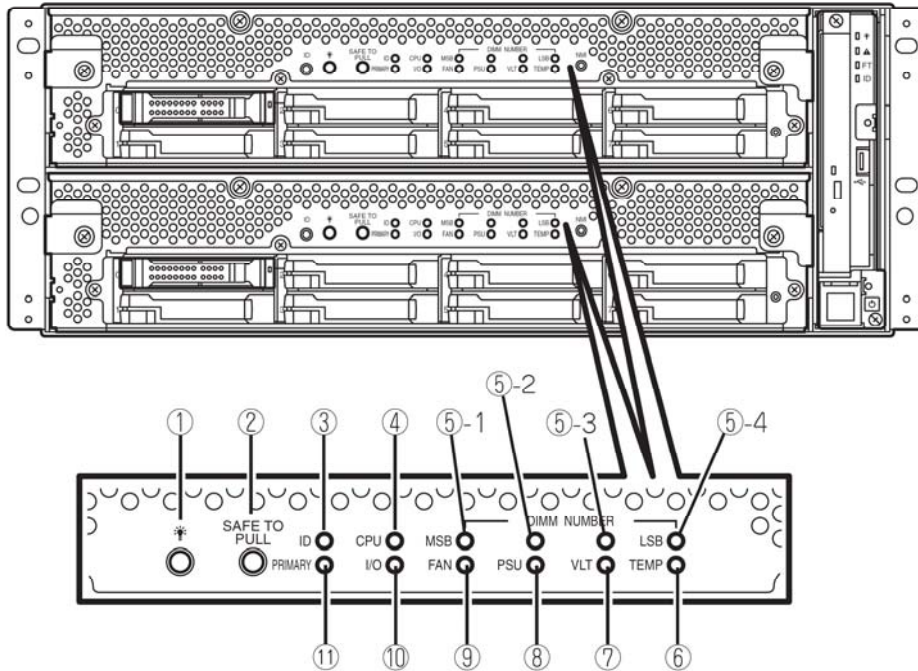

- (1) **Module POWER LED**
While the power of CPU/IO module is ON, the LED illuminates in green. When the power is not supplied to CPU/IO module, the LED goes off. The LED blinks when standing by.
Amber LED illuminates when failure occurs on CPU of CPU/IO module.
- (2) **SAFE TO PULL**
This is the LED indicating the possibility to remove CPU/IO module safely. The LED lights in green when it is able to remove CPU/IO module.
The LED blinks in green when it is unable to remove CPU/IO module.
The LED goes off when CPU/IO module is off line and it is able to remove it.
- (3) **Module ID(ID LED)**
The system ID LED illuminates in green on the front bezel if pressing UID switch when there are multiple devices installed on one rack. This enables to identify the device to be maintained. This LED blinks in blue when there are device identification requests remotely.
- (4) **CPU(CPU FAULT LED)**
The LED illuminates in amber when the CPU part of CPU/IO modules has an error.

(5) MEM NUMBER(Memory slot error LED)

Amber LED illuminates when failure occurs on the memory slot 0 of CPU/IO module. Memory slots with errors can be identified by illumination status of the following (5)-1 to 4.

Each Memory Slot Error LED Status				Description
5-1 (MSB)	5-2	5-3	5-4 (LSB)	
-	-	-	-	Operating normally.
-	-	-	√	An error occurred on memory slot 1.
-	-	√	-	An error occurred on memory slot 2.
-	-	√	√	An error occurred on memory slot 3.
-	√	-	-	An error occurred on memory slot 4.
-	√	-	√	An error occurred on memory slot 5.
-	√	√	-	An error occurred on memory slot 6.
-	√	√	√	An error occurred on memory slot 7.
√	-	-	-	An error occurred on memory slot 8.
√	-	-	√	An error occurred on memory slot 9.
√	-	√	-	An error occurred on memory slot 10.
√	-	√	√	An error occurred on memory slot 11.
√	√	-	-	An error occurred on memory slot 12.
√	√	√	√	An error occurred on unknown memory slot.

- √ LED is lit.
- LED is not lit.

(6) TMP (Abnormal temperature LED)

The LED lights in amber when temperature in CPU/IO module becomes abnormal.

(7) VLT (Power error LED)

The LED lights in amber when electric voltage failure occurs in CPU/IO module.

(8) PSU(Power supply unit error LED)

The LED lights in amber when failure occurs on the power supply unit of CPU/IO module.

(9) FAN (Fan error LED)

The LED lights in amber when failure occurs on the cooling fan for CPU of CPU/IO module.

(10) I/O(I/O FAULT LED)

The LED lights in amber when failure occurs on the I/O part of CPU/IO module.

(11) PRIMARY(Primary LED)

The LED lights in green when CPU/IO module is primary.

POWER UNIT LED

There is a power unit LED in the power unit on the rear. The LED blinks in green when connecting the power code to AC inlet and the power unit receives the power. The LED illuminates in green when turning the power of the device

The power unit may be failing if the LED does not illuminate in green or the LED illuminates or blinks in amber when turning the switch ON. Contact your sales agent to have the power unit replaced.

BASIC OPERATION

This section describes basic operation procedures of NEC Express5800/ft series.

Installing/removing the front bezel

When you power on/off the server, handle the DVD-ROM drive, or remove/install a hard disk drive or CPU/IO module, remove the front bezel.

IMPORTANT: The front bezel can only be removed by unlocking the lock with the security key attached. bezel.

1. Insert the product-accessory security key into the key slot and push lightly. Turn the key to the left to unlock.
2. Hold the right edge of the front bezel and pull it forward.
3. Slide the front bezel to take the tab off the frame and remove the front bezel.

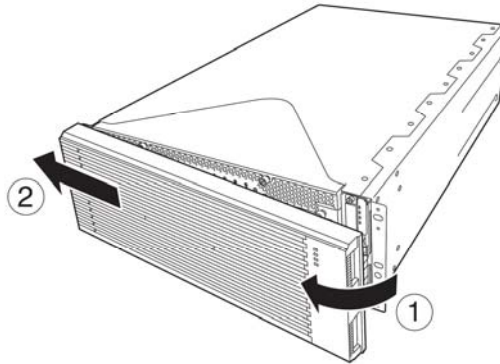

When attaching the front bezel, hook the left tab into the server's frame first, then push forward on the right side.

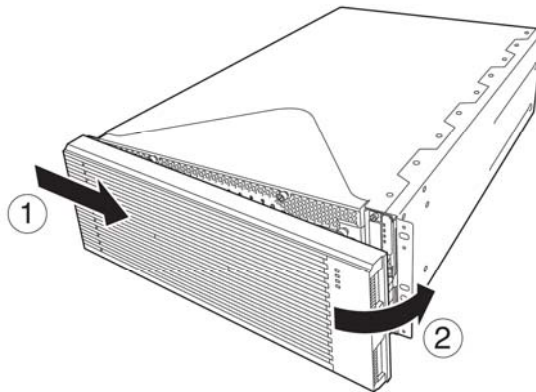

Power ON

To power on NEC Express5800/ft series, press the POWER switch (the one whose in-built LED is lit).

Follow the steps below to turn on the power.

1. Power on the display unit and other peripheral devices connected to the server.

CHECK: If the power code is connected to a power controller like a UPS, ensure that it is powered on.

2. Remove the front bezel.
3. Press the power switch located on the front panel. Lift up the acrylic cover in front of the power switch, and press power switch of the front panel.

After a while, the “NEC” logo will appear on the screen.

IMPORTANT: Do not turn off the power before you see the “NEC” logo and a character below the logo.

While the “NEC” logo is displayed on the screen, NEC Express5800/ft series is performing a power-on self test (POST) to check itself. For details, see “POST Check” described later in this chapter. Upon the completion of POST, OS will start.

CHECK: If the server finds errors during POST, it will interrupt POST and display the error message. See Chapter 7.

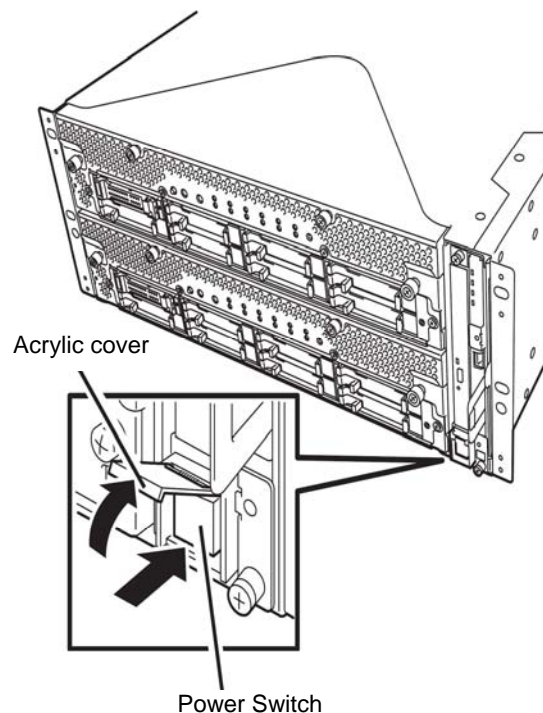

Power OFF

Follow the steps below to turn off the power. If NEC Express5800/ft series is plugged to a UPS, see manuals included with the UPS or the application that controls the UPS.

1. Perform a normal shutdown from OS.

The system will be powered off automatically. (Note: the POWER switch on the primary side will remain illuminating when AC power is supplied.)

2. Power off all peripheral devices.

POST Check

POST (power-on self test) is a self-test function stored on the motherboard of NEC Express5800/ft series.

When you power on the server, POST will start automatically to check the motherboard, ECC memory modules, CPU/IO modules, keyboard, mouse, etc. It also shows startup messages for various BIOS setup utilities.



According to the factory default settings, the “NEC” logo appears on the display while POST is being performed. (To view details of POST, press **Esc**.)

TIPS:

- You can view POST details from the beginning without pressing **Esc** key when the BIOS menu appears. Select [System Configuration] – [Advanced] and set [Boot-time Diagnostic Screen] to “Enabled” (see Chapter 4).
 - You can view the test items and details from a management PC where ESMPRO Manager is installed.
-

You do not always need to check POST details. You will need to check messages when:

- You install a new NEC Express5800/ft series.
- A failure is suspected.
- You hear several beeps between the time of the power-on and OS start-up.
- The display unit shows an error message.

Flow of POST

This section walks you through how POST is performed.

1. When you power on the system, one selected CPU/IO module will start up.
POST will be performed on this selected CPU/IO module.
2. Memory check starts.
A message appears at the upper left of the screen to show that the basic and expanded memories are being counted. The memory check may take a few minutes to complete depending on the server's memory size. Likewise, it may take about one minute for the screen to appear when the server is rebooted.
3. The server starts processor check, IO check, and initialization.
Several messages appear: they show the ID of the selected CPU/IO modules, information on the processor, detection of the keyboard and mouse, etc.
4. A message appears at the lower left of the screen, prompting for startup of the BIOS setup utility "SETUP:"

Press <F2> to enter SETUP

You will need to start it when you want to modify the configuration for using the server. Unless this message appears together with an error message, you do not need to start the utility to modify the configuration. (If you wait for a few seconds, POST will go on automatically.)

To start the SETUP utility, press **F2** while the above message is displayed. For setting and parameter functions, see the section of BIOS setup.

When SETUP is completed, the server will reboot itself automatically and perform POST.

5. A message appears prompting for startup of SAS BIOS setup utility.
When a built-in SAS controller is detected, a message will appear prompting for startup of SAS BIOS setup utility. (If you wait for a few seconds, POST will go on automatically.)
If you press **Ctrl + C**, the SAS BIOS setup utility will start. However, you usually do not need to use the setup utility. For setting and parameter functions, see "SAS BIOS" (page 4-33).

When SETUP is complete, the server will reboot automatically and perform POST from the start again.

6. The screen shows the ID numbers of the connected disk drive.

7. Upon completion of POST, the password entry screen appears prior to OS startup.

The password entry screen will appear after the normal termination of POST only if you have set a password in the BIOS setup utility “SETUP.”

You can enter a password up to three times. If you enter an incorrect password three times, the startup will be unsuccessful. In this case, turn off the power and then turn it on again after waiting 30 seconds to boot the server.

IMPORTANT: Set a password after the OS installation.

8. Upon completion of POST, the OS will start up.

Behavior at Occurrence of Error

If POST or OS startup does not finish normally, the server will reboot itself automatically.

At the time of reboot, it will select the other CPU/IO module and run POST or OS startup.

In this manner, the server retries POST or OS startup with different combinations of CPU/IO modules. If POST does not finish normally with any combinations, the server will stop with the state of DC OFF or Post end with an error message displayed.

While performing retries, the server displays or registers the error types.

For details of error messages, see Chapter 7 “Troubleshooting.”

POST Error Messages

When the server detects an error during POST, it will notify you of the occurrence in the following manners:

- Displays an error message on the display unit.

These notification methods are described in “POST Error Messages” (Page 7-4).

IMPORTANT: Before you contact your sales agent, write down the error messages. They will serve as helpful information at the time of maintenance.

CPU/IO Module Status

The CPU/IO module (0 or 1) started first is managed as primary, and the module started later is managed as secondary. If one CPU/IO module is disconnected because of the failure and others, the other module becomes primary.

The CPU/IO module to be started first is selected depending on the primary/secondary status of modules when the server was shut down the last time.

The following devices are connected to the primary CPU/IO module by the hardware switch, although those can be connected to both CPU/IO modules 0 and 1. When one CPU/IO module is disconnected because of a failure, those are switched to the other module automatically and continue operating.

- VGA (display)
- USB device (keyboard, mouse, floppy disk drive)

TIPS: Both CPU/IO modules 0 and 1 can access to the optical disk drive. If one CPU/IO module is isolated because of the failure, only the optical disk drive of the other module can access to the drive.

Floppy Disk Drive (Option)

If you want to use a floppy disk drive with this server, connect N8160-81 USB FDD UNIT, which are available optionally to a USB connector.

This server supports 3.5-inch 2HD (1.44 MB) and 2DD (720KB) floppy disks.

IMPORTANT:

- When using a USB floppy disk drive, the access to the floppy disk is delayed on rare occasions if the display graphic load is high because a moving picture is being played. In such a case, retry the operation with the floppy disk inside the floppy disk drive.
-

Insert/Remove Floppy Disk

Before inserting a floppy disk into the drive, make sure that NEC Express5800/ft series is on (the POWER LED illuminates).

Insert a floppy disk into the drive firmly until it snaps in place. The eject button of the drive is then raised slightly.

CHECK:

- You cannot use 1.2 MB-formatted disks.
 - If you insert an formatted disk, you will see a message that the disk cannot be read or that needs formatting. To format a floppy disk, refer to your OS manual.
 - If you power on or restart NEC Express5800/ft series with a floppy disk left in the drive, the server will access the floppy disk to start the system. Unless a system exits on the FD, the server will be unable to start.
-

To remove a floppy disk from the drive, press the eject button.

IMPORTANT:

- Before removing a floppy disk, ensure that the floppy disk access LED is off. If you eject a floppy disk while the LED is lit, the stored data could be damaged.
 - When using a USB floppy disk drive, access to the floppy disk is delayed on rare occasions if the display graphic load is high because a moving picture is being displayed. In such a case, retry the operation with the floppy disk inside the floppy disk drive.
-

Use of Floppy Disk

You may need to store important data on floppy disks. Since the floppy disk is a very delicate medium, you must handle it with extra care:

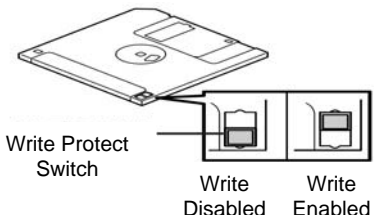
- Push the floppy disk gently into place.
- Attach the label on a proper position.
- Do not use a pencil or ballpoint pen to write on the floppy disk.
- Do not open the protective shutter.
- Do not use the floppy disk in a dusty place.
- Do not place anything on the floppy disk.
- Do not leave the floppy disk in a place that is subject to direct sunlight or high temperatures (e.g., near a heater).
- Keep away from cigarette smoke.
- Do not leave the floppy disk near water or chemicals.
- Keep away from magnetic objects.
- Do not clip disks. Be careful not to drop.
- Store floppy disks in a protective case where they are kept away from magnetic waves or dust.
- To prevent data from being erased accidentally, the floppy disk has a write-protect notch. When the disk is write-protected, you can read data, but you cannot write the data or format the disk. It is recommendable to write-protect floppy disks that contain important data except when you write data to the floppy disk. To write-protect a 3.5-inch floppy disk, slide the write-protect notch located on its back.
- The floppy disk is a very delicate storage medium. Dust or changes in temperature could cause data to be lost. Data loss could also be caused by faulty operation and computer trouble. To avoid such possible data loss, it is recommendable to back up important data regularly. (Be sure to make back-up copies of the floppy disks that are included with NEC Express5800/ft series.)

DVD-ROM drive

NEC Express5800/ft series has a DVD-ROM drive on the front panel. It is a device used to read data from an optical disk (compact disc read-only memory). Compared to a floppy disk, an optical disk allows for larger volume and fast data readout.

⚠ CAUTION



Observe the following instructions to use the server safely. There are risks of a burn, injury, or damage to physical assets. For details, see "PRECAUTIONS FOR SAFETY" in Chapter 1.

- Do not leave the DVD-ROM drive tray ejected.

Insert/Remove Optical Disk

Follow the steps below to set an optical disk.

1. Before you insert an optical disk, make sure that the server is powered on. When the server is powered on, the LED lights in green.
2. Press the tray-eject button located in the front of the DVD-ROM drive. The tray is then ejected.
3. Hold the optical disk with its signaling side facing the tray.
4. As shown in the figure on the right, place the optical disk on the tray and press lightly on the center to lock.
5. Push the front side of the tray gently to the drive-closed position.

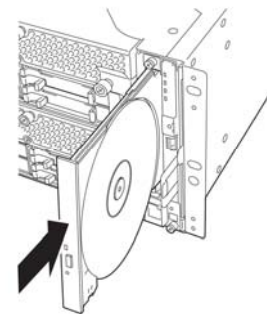
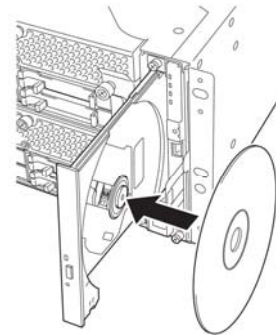
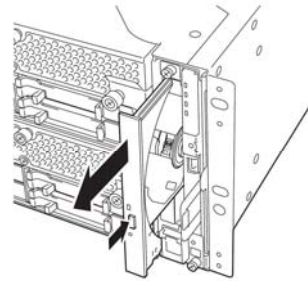

IMPORTANT:

If you hear noise while running the DVD-ROM drive, reset the optical disk.

To remove the optical disk, press the tray-eject button as you did in setting the optical disk.

When the access LED illuminates in green, it indicates the optical disk is being accessed. Make sure the access LED is not illuminating in green before you press the tray-eject button.

Press the locking part in the center of the tray and pick the optical disk gently. When you have removed the optical disk, push the tray to the drive-closed position.

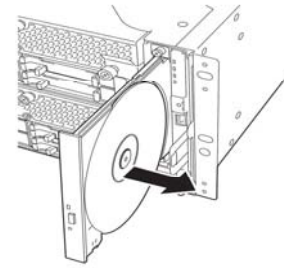

When you cannot eject a DVD/CD-ROM

When you cannot eject the optical disk from the server even by pressing the eject button, follow the steps below to eject it:

1. Press the POWER switch to power off this server (i.e. the POWER LED is off).
2. Use a metal pin of about 1.2 mm in diameter and 100 mm long (alternatively, you can use a fairly large paper clip after straightening). Insert it gently into the manual release hole located at the low front side of the server until the tray is ejected.

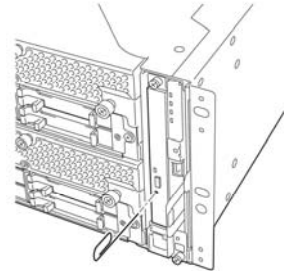

IMPORTANT:

- Do not use a toothpick, plastic pin, or other breakable objects.
 - If you cannot eject the optical disk by following the steps above, contact your sales agent.
-

3. Hold the tray and pull it out.
4. Take out the optical disk.
5. Push the tray back.

Handling optical disks

Observe the following when you use an optical disk on NEC Express5800/ft series:

- As for a disk such as a noncompliant “copy-protected CD,” we shall not guarantee that you can use a CD player to play it with this server.
- Be careful not to drop the optical disk.
- Do not bend or place anything on the optical disk.
- Do not attach labels on the optical disk.
- Do not touch the signal side (blank side).
- Place the optical disk gently on the tray with the printed side up.
- Do not scratch, or use a pencil or ballpoint pen to write on the optical disk.
- Keep away from cigarette smoke.
- Do not leave the optical disk in a place that is subject to direct sunlight or high temperatures (e.g., due to a heater).
- If the optical disk becomes dirty with dust or fingerprints, wipe it gently from its center to edge with a dry soft cloth.
- When you clean the optical disk, use the cleaner expressly meant for it. Do not use a record cleaner (spray), benzine, or thinner.
- Store the optical disk in a protective case when not in use.

Chapter 3

Linux Setup and Operation

This chapter describes setup procedures to make NEC Express5800/ft series ready for use. CPU/IO module has a processor function part and IO function part. In utilities in this chapter, the processor function part is referred to as CPU module and IO function part PCI module.

DISK OPERATIONS

NEC Express5800/ft series duplicates disks to secure data integrity by Software-RAID. This section describes how to replace a disk.

IMPORTANT:

It is recommended to create only a system partition on the disks with OS.

When you create a partition other than a system partition on the disk with the OS, note the following:

If you reinstall the OS, the entire disk will be cleared. If there is any data partition other than the system partition, the data must be backed up before reinstalling the OS.

Operable disk configuration

RAID must be configured for all the internal disks in NEC Express5800/ft series.

As shown on the below chart, the internal disks redundancy is configured by software RAID with the internal disks of corresponding slots.

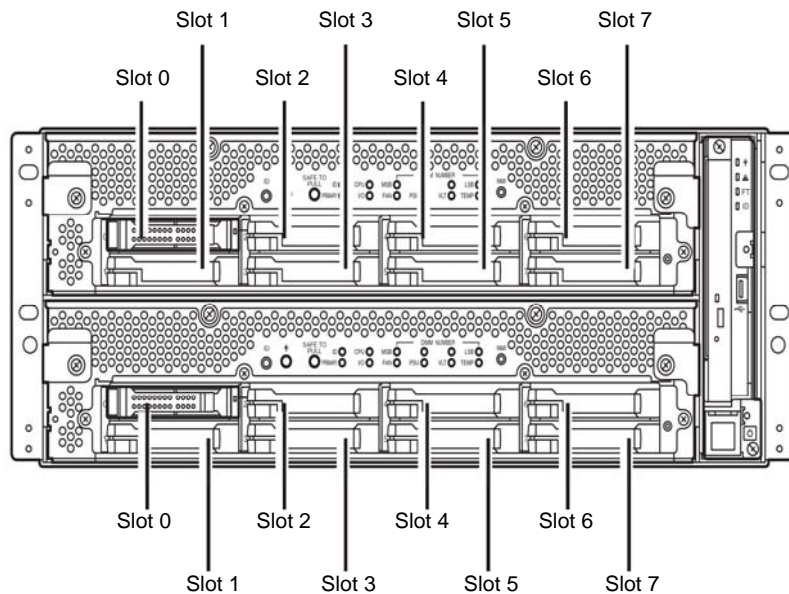

Slots corresponding to the mirroring process

Corresponding slot	
PCI module 10 Slot 0	⇔ PCI module 11 Slot 0
PCI module 10 Slot 1	⇔ PCI module 11 Slot 1
PCI module 10 Slot 2	⇔ PCI module 11 Slot 2
PCI module 10 Slot 3	⇔ PCI module 11 Slot 3
PCI module 10 Slot 4	⇔ PCI module 11 Slot 4
PCI module 10 Slot 5	⇔ PCI module 11 Slot 5
PCI module 10 Slot 6	⇔ PCI module 11 Slot 6
PCI module 10 Slot 7	⇔ PCI module 11 Slot 7

* In the table above, PCI module names correspond as follows:
 PCI module (for CPU/IO module 0) - PCI module 10
 PCI module (for CPU/IO module 1) - PCI module 11

IMPORTANT:

When the status of each disk becomes RESYNC, RECOVERY, CHECK or REPAIR, do not add a disk, insert/remove HDD, power off or restart the system. Wait until the status turns to DUPLEX. Check the status of RAID using the `ftdiskadm` command, which is described later in this document. For more information, see the User's Guide (Setup).

Use only the hard disk drives specified by NEC. There is a risk of hard disk as well as the entire device breakdown when you install a third-party hard disk drive.

Purchase two, paired hard disk drive of the same model to configure the hard drive redundancy. For information on which HDD suits this device the best, ask your sales agent.

The operation such as mounting for a partition of an internal disk is done for the RAID device (`md`) that is configured by Software -RAID but not for partition.

For the `ftdiskadm` command described later in this document, slot numbers of internal disks are allocated as follows;

Disk slot number for H/W	Disk slot number for <code>ftdiskadm</code>
PCI module 0 Slot 0	Slot 1
PCI module 0 Slot 1	Slot 2
PCI module 0 Slot 2	Slot 3
PCI module 0 Slot 3	Slot 4
PCI module 0 Slot 4	Slot 5
PCI module 0 Slot 5	Slot 6
PCI module 0 Slot 6	Slot 7
PCI module 0 Slot 7	Slot 8
PCI module 1 Slot 0	Slot 9
PCI module 1 Slot 1	Slot 10
PCI module 1 Slot 2	Slot 11
PCI module 1 Slot 3	Slot 12
PCI module 1 Slot 4	Slot 13
PCI module 1 Slot 5	Slot 14
PCI module 1 Slot 6	Slot 15
PCI module 1 Slot 7	Slot 16

Replacing a hard disk drive

To replace a failing hard disk, follow the steps below. Replace a hard disk when the CPU/IO module 0 and 1 are powered on.

Determining a failing disk

This section provides information on how to determine a failing hard disk drive.

IMPORTANT:

This must be operated by root user.

1. In the `ftdiskadm` command, select and execute [List RAID Arrays], and the information on the device (md) for each RAID is displayed.
2. Check the failed disk from the displayed info.
In the Member column, if [F] is displayed, it means the partition of corresponding disk is having a failure. The number enclosed with brackets is a slot number telling you which partitions of the internal disk is having a problem.

The following is an example when a failure occurred on the internal disk stored in the slot 9 (PCI module 1 – Slot 0).

```
# ftdiskadm

Command action
 1 List RAID Arrays
 2 List Internal Disks
 3 Make Mirroring Arrays (RAID1)
 4 Repair Mirroring Arrays (RAID1)
 5 Delete Mirroring Arrays (RAID1)
 6 Remove Disk Partitions (RAID1)
 7 Make Striping Array (RAID1+0)
 8 Delete Striping Array (RAID1+0)
 c Configurations
 q Quit

Command: 1

[List RAID Arrays]

Name Partition (Label) Status Member
=====
<Mirroring Array (RAID1)>
md0 /boot ( - ) DUPLEX (1)sda1 (9)sdi1
md1 Swap ( - ) DUPLEX (1)sda2 (9)sdi2
md2 / ( - ) SIMPLEX (1)sda3 F(9)sdi3
md3 /var/crash ( - ) DUPLEX (1)sda5 (9)sdi5
```

Restoring the redundant configuration manually

This section provides information on how to replace a failing internal disk and restore duplication.

IMPORTANT:

This must be operated by root user.

While the replaced disk is restoring to the RAID configuration, do not stop/restart the system when the reconfigured each RAID device is in RECOVERY. Wait until their status turns to DUPLEX. Note that the wait time is proportional to the disk volume.

1. In the command prompt of `ftdiskadm`, select [Remove Half Disk (RAID1)] to specify the slot number of the internal disk to replace, and isolate the disk from the RAID configuration.
2. Remove the disk from the system, and then, insert a new disk.
3. Wait approximately five minutes until the system automatically performs resynchronization.
4. If the system does not perform resynchronization automatically in step 3, recover RAID manually by selecting [Repair Mirroring Arrays (RAID1)] in `ftdiskadm`.

The following is an example of command prompt for the procedure from isolating the internal disk stored in the slot 9 (PCI module 1 - Slot 0) through restoring redundancy.

```
# ftdiskadm

Command action
 1 List RAID Arrays
 2 List Internal Disks
 3 Make Mirroring Arrays (RAID1)
 4 Repair Mirroring Arrays (RAID1)

 5 Delete Mirroring Arrays (RAID1)

 6 Remove Disk Partitions (RAID1)
 7 Make Striping Array (RAID1+0)
 8 Delete Striping Array (RAID1+0)
 c Configurations
 q Quit

Command: 6 (Isolate the disk specified with the slot number
from the RAID configuration.)

[Remove Disk Partitions (RAID1)]
* Which SCSI SLOT? [1-16] 9

mdadm: hot removed /dev/sdi5
mdadm: hot removed /dev/sdi3
mdadm: hot removed /dev/sdi2
mdadm: hot removed /dev/sdi1
```

```
Command action
```

- ```

1 List RAID Arrays
2 List Internal Disks
3 Make Mirroring Arrays (RAID1)
4 Repair Mirroring Arrays (RAID1)
5 Delete Mirroring Arrays (RAID1)
6 Remove Disk Partitions (RAID1)
7 Make Striping Array (RAID1+0)
8 Delete Striping Array (RAID1+0)
c Configurations
q Quit
```

```
Command: 1 (Check if the disk specified is isolated from
the RAID configuration.)
```

```
[List RAID Arrays]
```

```

Nam Partition (Label) Status Member
e
=====
=====
< Mirroring Array (RAID1) >
md0 /boot (-) SIMPLEX (1)sda1
md1 swap (-) SIMPLEX (1)sda2
md2 / (-) SIMPLEX (1)sda3
md3 /var/cras (-) SIMPLEX (1)sda5
h
```

(After verifying the isolation of the specified disk from the RAID configuration (verifying no partition of the specified disk is in Member), replace the hard disk. Wait approximately five minute before the system starts to resynchronize. If there is no automatic synchronization, manually restore the disk with the below procedure.)

```
Command action
```

- ```

1 List RAID Arrays
2 List Internal Disks
3 Make Mirroring Arrays      (RAID1)
4 RepairMirroringArrays    (RAID1)
5 DeleteMirroringArrays    (RAID1)
6 Remove Disk Partitions     (RAID1)
7 Make Striping Array        (RAID1+0)
8 Delete Striping Array      (RAID1+0)
c Configurations
q Quit
```

```
Command: 2 (Check if the replaced disk is recognized by
the system.)
```

```
[List Internal Disks]
```

```

Slo  Name [use]  Information      (Vendor/Model/Serial)
t                                         path
=====
```



```

=====
1      sda (sdq)   [3]           AAA/BBB/#CCC h5c0t12810
2      -
3      -
4      -
5      -
6      -
7      -
8      -
9      sdd (sdr)  [3]           AAA/BBB/#CCC h6c0t12810
10     -
11     -
12     -
13     -
14     -
15     -
16     -

```

Command action

- 1 List RAID Arrays
- 2 List Internal Disks
- 3 Make Mirroring Arrays (RAID1)
- 4 Repair Mirroring Arrays (RAID1)
- 5 Delete Mirroring Arrays (RAID1)
- 6 Remove Disk Partitions (RAID1)
- 7 Make Striping Array (RAID1+0)
- 8 Delete Striping Array (RAID1+0)
- c Configurations
- q Quit

Command: 4 (If the system does not synchronized the replaced disk automatically, execute the below command to restore to the RAID configuration manually.)

```

[Repair           Mirroring
Arrays(RAID1)]
* Which SCSI SLOT? [1-16] 9

```

Command action

- 1 List RAID Arrays
- 2 List Internal Disks
- 3 Make Mirroring Arrays (RAID1)
- 4 Repair Mirroring Arrays (RAID1)
- 5 Delete Mirroring Arrays (RAID1)
- 6 Remove Disk Partitions (RAID1)
- 7 Make Striping Array (RAID1+0)
- 8 Delete Striping Array (RAID1+0)
- c Configurations
- q Quit

Command: 1 (Check if the resynchronization process is started.)

```

[List of RAID Arrays]
Name Partition (Label Status Member
e )
=====
=====
<MirroringArray (RAID1)>
md0 /boot ( - ) RECOVERY (1)sda1 R(9)sdi1
(62%)
md1 swap ( - ) RESYNC (1)sda2 R(9)sdi2
md2 / ( - ) RESYNC (1)sda3 R(9)sdi3
md3 /var/cras ( - ) RESYNC (1)sda5 R(9)sdi5
h

(Perform restoration (RECOVERY) to each RAID devices (md).
After a while, check the Status with the below command.
"RESYNC" shows it is waiting to be restored. "R" is displayed
on the left side of the Member. This indicates the disk
partition is either waiting to be restored or is in the process
of restoring.)

Command action
1 List RAID Arrays
2 List Internal Disks
3 Make Mirroring Arrays (RAID1)
4 Repair Mirroring Arrays (RAID1)
5 Delete Mirroring Arrays (RAID1)
6 Remove Disk Partitions (RAID1)
7 Make Striping Array (RAID1+0)
8 Delete Striping Array (RAID1+0)
c Configurations
q Quit

Command: 1

Name Partition (Label Status Member
e )
=====
=====
<MirroringArray (RAID1)>
md0 /boot ( - ) DUPLEX (1)sda1 R(9)sdi1
md1 swap ( - ) DUPLEX (1)sda2 R(9)sdi2
md2 / ( - ) DUPLEX (1)sda3 R(9)sdi3
md3 /var/cras ( - ) DUPLEX (1)sda5 R(9)sdi5
h

(When the each RAID device Status is DUPLEX, the RAID
configuration is restored normally. This ends the disk
replacement procedure.)

```

DUPLEX LAN CONFIGURATION

NEC Express5800/ft series uses Bonding for duplex of 1000 BASE LAN cards controlled by the igb driver and builds them as bond*(*=0,1,2...) device.

Functional overview

For duplicating a LAN, active backup for bonding is used. Active backup is a coupled-interface using multiple LAN controllers. When only active LAN controller fails, this function allows for continued operation by immediately switching to a backup controller.

Operable network configuration

For NEC Express5800/ft series, network interface names are based on the naming convention as described in the table below. Network duplication is achieved by pairing network interfaces of PCI slots in CPU/IO module 0 and network interfaces in the same PCI slots in CPU/IO module 1.

PCI slot and network interface name

PCI slot	Port	CPU/IO module 0	CPU/IO module 1
On Board	#1	eth100600 (1)	eth110600 (1)
	#2	eth100601 (2)	eth110601 (2)
PCI-e slot 1	#1	eth100100 (3)	eth110100 (3)
	#2	eth100101 (4)	eth110101 (4)
PCI-e slot 2	#1	eth100200 (5)	eth110200 (5)
	#2	eth100201 (6)	eth110201 (6)
PCI-e slot 3	#1	eth100300 (7)	eth110300 (7)
	#2	eth100301 (8)	eth110301 (8)
PCI-e slot 4	#1	eth100400 (9)	eth110400 (9)
	#2	eth100401 (10)	eth110401 (10)

*The number enclosed with brackets in the CPU/IO module column is slot numbers allocated by vndctl described later. The slot numbers are allocated one-to-one to each interface pair.

Configuring duplication

The following shows information on how to configure duplication by using the settings shown below as an example.

```
<Configuration information>
Slot number: 3
SLAVE0 interface name: eth100100
SLAVE1 interface name: eth110100
IP address: 192.168.0.1
Subnet mask: 255.255.255.0
Default gateway: 192.168.0.1
```

IMPORTANT:

This must be operated by root user.

1. Execute the following command. Configure network interfaces eth100100 and eth110100 that are corresponding to slot 3 as a coupled interfaces.

```
# vndctl add 3
```

2. Execute the command below to configure the network settings (the parts with * are to be specified by a user) on the combined interface that has been constructed. When you enter default gateway, you can omit the process by pressing ENTER without specifying anything.

```
# vndctl config 3
*Boot Protocol? [none/dhcp/bootp] none
*IP address? 192.168.0.1
*Netmask? 255.255.255.0
*Default gateway (IP)? 192.168.0.1

*Are you sure to set it? [y/n] y

DEVICE=bond2
ONBOOT=yes
BOOTPROTO=none
IPADDR=192.168.0.1
NETMASK=255.255.255.0
GATEWAY=192.168.0.1
```

3. Execute the following command to activate the configured coupled-interfaces.

```
# vndctl up 3
```

4. Execute the following command to check the status of the configured coupled-interfaces.

```
# vndctl status

--Virtual Network Status--
BondingDevice Slot Status InetAddress RXErrors TXErrors Collisions
bond0          1  ONLINE -                0          0          0
bond1          2  ONLINE -                0          0          0
bond2          3  ONLINE 192.168.0.1      0          0          0
bond3          -  OFFLINE -                0          0          0
bond4          -  OFFLINE -                0          0          0
bond5          -  OFFLINE -                0          0          0
bond6          -  OFFLINE -                0          0          0
bond7          -  OFFLINE -                0          0          0
bond8          -  OFFLINE -                0          0          0
bond9          -  OFFLINE -                0          0          0

Slot      RealDevice  Status  Interface  LinkState  LinkSpeed
1  top      eth100600  DUPLEX    UP         LINK       1000Mb/s-FD
   bottom  eth110600  DUPLEX    UP         LINK       1000Mb/s-FD
2  top      eth100601  DUPLEX    UP         LINK       1000Mb/s-FD
```

	bottom	eth110601	DUPLEX	UP	LINK	1000Mb/s-FD
3	top	eth100100	DUPLEX	UP	LINK	1000Mb/s-FD
	bottom	eth110100	DUPLEX	UP	LINK	1000Mb/s-FD

When bond2 (bond 0 and bond 1 are configured by default.) is configured for the slot 3 and as shown above, and the status of each SLAVE interface (eth100100, eth110100) is DUPLEX, duplication is successfully completed.

CHECKING THE DUPLICATING OPERATION OF MODULES

This section describes how to check if the system runs properly after system installation or reinstallation. CPU/IO module has a processor function part and IO function part. Each part is monitored and managed by the module. In this section, the processor function part is referred to as CPU module and IO function part PCI module.

Evaluate Startup and Stop of PCI Modules

This section describes how to confirm the continuous system operation by failover after stopping the primary PCI module.

1. Check which is the primary PCI module.
The PCI module with the POWER switch illuminated is the primary module.
2. Check whether the PCI modules are duplicated.
To check if the PCI modules are duplicated, see the CPU/IO modules' status LEDs.

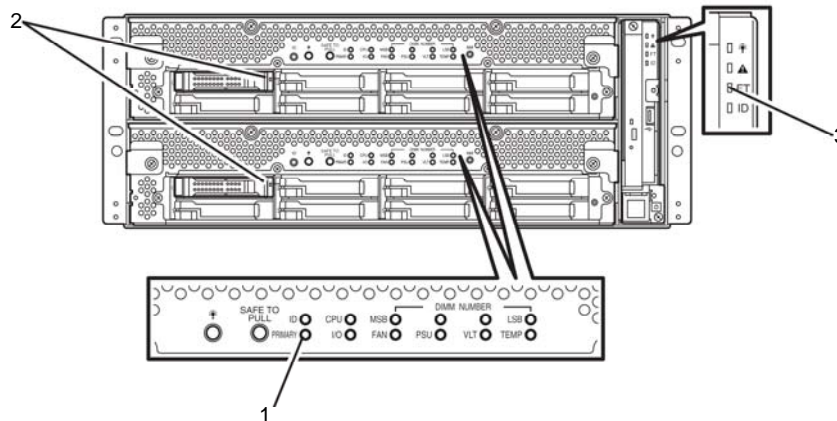

[Indications of the status LEDs when PCI modules are duplicated]

	LED	Primary	Secondary
1	PRIMARY LED	Green	-
2	DISK ACCESS LED	Green	Green

	LED	System
3	System FT LED	Green

3. Stop the operation of a PCI module using the ft server utility.
Move to the directory where the NEC ESMPRO Agent is installed.

```
# cd /opt/nec/esmpro_sa/bin
```

Start the ft server utility.

```
# ./ESMftcutil
```

The screen of the ft server utility will appear.

Select [ftServer] - [PCI Module] - [PCI Module (to be removed)]. The screen of the PCI Module(to be removed) will appear.

Select [PCI Module Start/Stop] - [Stop] to the stop of the PCI .Module.

* As for the primary PCI module (*), if the PCI module 0 is primary select [PCI Module(ID:10)]. If the PCI module 1 is primary, select [PCI Module (ID:11)].

When you stop the operation of the primary PCI module, a failover occurs and the secondary PCI module becomes the primary module.

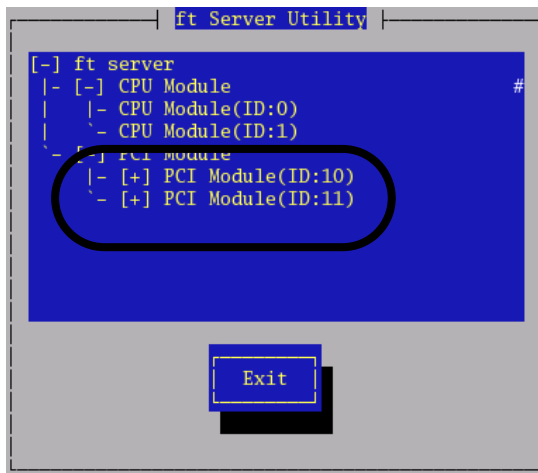

ft server utility

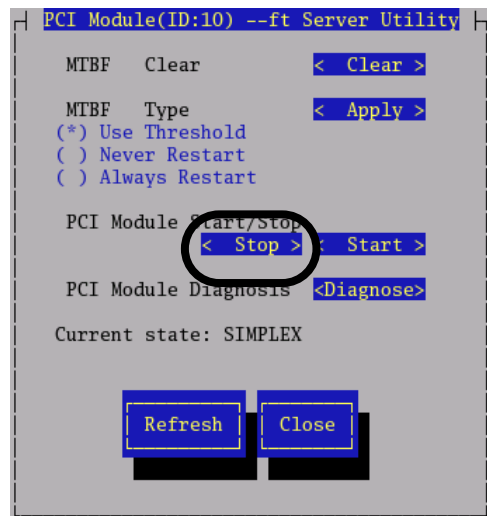

PCI Module

4. Restart the PCI module.

From the ft server utility, click [Start] of [PCI Module Start/Stop] to the PCI module which was stopped in the step 3, and the PCI module will be started. Once the PCI module is started, PCI module diagnosis, mirror volume duplication and PCI module duplication are performed.

The PCI modules' status LEDs changes as shown below:

[Indications of the status LEDs]

Immediately after the PCI module startup until the completion of diagnosis:

LED		Secondary	Primary
1	PRIMARY LED	-	Green
2	DISK ACCESS LED	-	Amber or Green blinking (Green when accessing to HDD)

LED		System
3	System FT LED	-



When duplication of disks is started after the completion of PCI module diagnosis:

* The status of LEDs varies depending on the method of disk duplication.

LED		Secondary	Primary
1	PRIMARY LED	-	Green
2	DISK ACCESS LED	Amber or Green blinking (Green when accessing to HDD)	Amber or Green blinking (Green when accessing to HDD)

LED		System
3	System FT LED	-



After the completion of disk duplication and when the PCI modules are duplicated:

LED		Secondary	Primary
1	PPRIMARY LED	-	Green
2	DISK ACCESS LED	Green blinking	Green blinking

LED		System
3	System FT LED	Green

Confirm Start and Stop of CPU Modules

This section describes how to confirm the continuous system operation after stopping one of the CPU modules.

1. Confirm that the CPU modules are duplicated.
To check if the CPU modules are duplicated, see the status LEDs of the CPU modules.

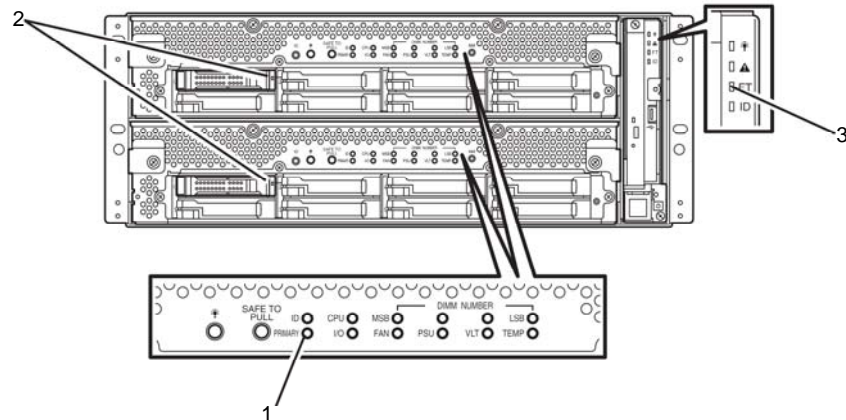

[Indications of status LEDs when CPU modules are duplicated]

LED		Secondary (Operating)	Primary (Operating)
1	PRIMARY LED	Green	-
2	DISK ACCESS LED	Green	Green

LED		System
3	System FT LED	Green

2. Use the ft server utility to stop the operation of a CPU module to remove.
Move to the directory where the ft server utility of NEC ESMPRO Agent is installed.
cd/opt/nec/esmpro_sa/bin/
Start the ft server utility.
./ESMftcutil
The screen of the ft server utility will appear.
Select [ftServer] - [CPU Module] - [CPU Module (to be removed)]. The screen of the CPU Module(to be removed) will appear.
Select [CPU Module Start/Stop] - [Stop] to the stop of the CPU .Module.
* As for the CPU module to stop, select [CPU Module(ID:0)] to stop CPU module 0, select [CPU Module(ID:1)] to stop CPU module 1.

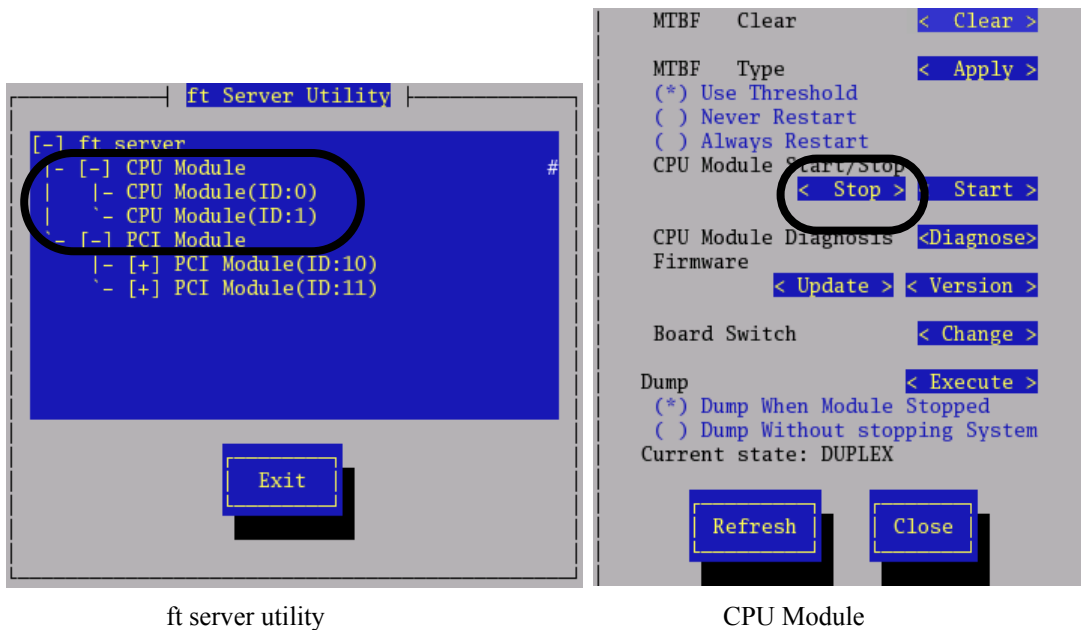

ft server utility

CPU Module

- Restart the CPU module.
In the ft server utility, select the stopped CPU module and click [Start] of [CPU Module Start/Stop].
Once the CPU module is started, hardware diagnosis and then synchronization of memory (memory copy) are performed, and the duplication process is completed.
Note that the system is paused temporarily for copying memory during memory synchronization.

[Indications of status LEDs after completion of duplication]

LED		Secondary (Operating)	Primary (Operating)
1	PRIMARY LED	Green	-
2	DISK ACCESS LED	Green	Green

LED	System
3	System FT LED Green

IMPORTANT:

After duplication is completed, the FT LED illuminates in green.

Do not perform the evaluation of start and stop unless the above process is completed.

ft Server service

NEC Express5800/ft series provides the services required for the system operation by the following service programs in addition to the dedicated drivers.

Service names:

- kdump
- ft-firstboot
- snmpd
- portmap
- ESMntserver
- ESMamvmain
- ESMftreport
- ESMcmn
- ESMfileys
- ESMlan
- ESMIS
- ESMps
- ntagent

The service programs above are required for operating NEC Express5800/ft series. Do not stop them.

Notes on access to USB FDD

When you attempt an access by directly specifying an sd device name as described below while a USB FDD is connected, the device name may be changed due to separation or integration of one of the PCI modules, which can destroy partition information etc. of other disks unintentionally.

[Example]

If you execute a command for the USB FDD after you integrate one of the PCI modules with the same sd device name that was specified before the system was separated, partition information etc. of the disk A is destroyed.

Transition of sd device names

	Disk A	USB FDD	Disk B
Before one of the PCI modules is separated	sda	sdb	sdc
After one of the PCI modules is separated	none	sda	sdc
After one of the PCI modules is integrated	sdb	sda	sdc

- 1) Before one of the PCI modules is separated

```
# tar cf /dev/sdb files
```

→ Files are written in the USB FDD.

- 2) After one of the PCI modules is integrated

```
# tar cf /dev/sdb files
```

→ Files are written in the disk A unintentionally → partitions are destroyed



Note:

It is a feature of NEC Express5800/ft series that the device names of the device files change due to integration or separation of one of the PCI modules.

Configuring the video mode

This section describes how to configure the video mode for this device.

1. Open `/etc/X11/xorg.conf` as a root user by using an editor.

IMPORTANT:

`xorg.conf` is a very important file for the X server system. It is recommended to create a backup because corrupting `xorg.conf` can result in failure to start up the X server in the worst case scenario. When you make a backup, use a different file name for the backup since the file name `/etc/X11/xorg.conf.backup` is used by the system.

2. Modify the following configuration in `xorg.conf`.

Enter the value you want to configure in (1)'s `Modeline` in the (2)'s `Modes` line.

Changing the numbers of colors

Change the value indicated by (3) to the number of colors you want (8bpp, 16bpp or 24bpp).

If you have chosen 24bpp, delete # at the top of the line indicated by (4). (If you have chosen 8bpp or 16bpp, make sure the line starts with #. If there is no #, enter it.)

```
Section "Monitor"
    Identifier "Monitor0"
    VendorName "Monitor Vendor"
    ModelName "Unprobed Monitor"
    HorizSync 30.0 - 95.0
    VertRefresh 60.0 - 180.0
    Modeline "1024x768 @ 60Hz" 65.0 1024 1048 1184 1344 768 771 777 806 -hsync -vsync
    Modeline "1024x768 @ 70Hz" 75.0 1024 1048 1184 1328 768 771 777 806 -hsync -vsync
    Modeline "1024x768 @ 75Hz" 78.8 1024 1040 1136 1312 768 769 772 800 +hsync +vsync
    Modeline "640x480 @ 60Hz" 25.2 640 656 752 800 480 492 525 -hsync -vsync
    Modeline "800x600 @ 60Hz" 40.0 800 840 968 1056 600 601 605 628 +hsync +vsync
    Modeline "800x600 @ 72Hz" 50.0 800 856 976 1040 600 637 643 666 +hsync +vsync
    Modeline "800x600 @ 75Hz" 49.5 800 816 896 1056 600 601 604 625 +hsync +vsync
    Modeline "800x600 @ 85Hz" 56.3 800 832 896 1048 600 601 604 631 +hsync +vsync
    Option "dpms"
EndSection

Section "Device"
# Driver "ati"
    Identifier "Videocard0"
    Driver "fbdev"
    VendorName "Videocard vendor"
    BoardName "ATI Radeon RV100 framebuffer mode"
    Option "UseFBDev"
EndSection

Section "Screen"
# Uncomment next line if DefaultDepth 24 only
# DefaultFbBpp 24
    Identifier "Screen0"
    Device "Videocard0"
    Monitor "Monitor0"
    DefaultDepth 16
    SubSection "Display"
        Viewport 0 0
        Depth 16
        Modes "800x600 @ 75Hz"
    EndSubSection
    SubSection "Display"
        Viewport 0 0
        Depth 24
        Modes "1024x768 @ 75Hz" "1024x768 @ 70Hz" "1024x768 @ 60Hz" "800x600 @ 85Hz" "800x600 @ 75Hz" "800x600 @
72Hz" "800x600 @ 60Hz"
```

3. If the X server is started, shut down the server by entering `'init 3'` in a command line.

4. The mode is switched to the console mode (CUI), and then, start up the X server by entering `'init 5'` in a command line.

**Note:**

- You cannot use xrandr to modify the resolution because the xrandr function is not supported.
- If you use the X server on the console, operate the system at the run level 5 and perform graphical login. If X is not started when the system is started (i.e run level 3), log in as root and enter "init 5" from a command line on the text console to start the X server.
- You cannot change the resolution and the number of colors from application menu due to hardware specification.

If you cannot restore the system since you have changed the resolution from application menu, follow the steps below.

- (1) Switch to the console mode. (Enter "init 3" in the command line. If the window cannot be displayed, press [Ctrl] + [Alt] + any one of the keys from F1 through F6 to switch to the console mode, and then log in as a root user and type "init 3".)
- (2) Open /etc/X11/xorg.conf by an editor.
- (3) The value of Modes in (2) is as shown in the figure below. Select the value you want to configure in (1)'s ModeLine and enter it in the (2)'s Modes line.
- (4) Enter "init 5" in the command line to start the X server.

```

Section "Monitor"
    Identifier      "Monitor0"
    VendorName     "Monitor Vendor"
    ModelName      "Unprobed Monitor"
    HorizSync      30.0 - 95.0
    VertRefresh    60.0 - 180.0
    ModeLine       "1024x768 @ 60Hz" 65.0 1024 1048 1184 1344 768 771 777 806 -hsync -vsync
    ModeLine       "1024x768 @ 70Hz" 75.0 1024 1048 1184 1328 768 771 777 806 -hsync -vsync
    ModeLine       "1024x768 @ 75Hz" 78.8 1024 1040 1136 1312 768 769 772 800 +hsync +vsync
    ModeLine       "640x480 @ 60Hz" 25.2 640 656 752 800 480 490 492 525 -hsync -vsync
    ModeLine       "800x600 @ 60Hz" 40.0 800 840 968 1056 600 601 605 628 +hsync +vsync
    ModeLine       "800x600 @ 72Hz" 50.0 800 856 976 1040 600 637 643 666 +hsync +vsync
    ModeLine       "800x600 @ 75Hz" 49.5 800 816 896 1056 600 601 604 625 +hsync +vsync
    ModeLine       "800x600 @ 85Hz" 56.3 800 832 896 1048 600 601 604 631 +hsync +vsync
    Option         "dpms"
EndSection

Section "Device"
#       Driver       "ati"
    Identifier     "Videocard0"
    Driver         "fbdev"
    VendorName     "Videocard vendor"
    BoardName      "ATI Radeon RV100 framebuffer mode"
    Option         "UseFBDev"
EndSection

Section "Screen"
# Uncomment next line if DefaultDepth 24 only
#       DefaultFbBpp 24
    Identifier     "Screen0"
    Device         "Videocard0"
    Monitor        "Monitor0"
    DefaultDepth   16
    SubSection     "Display"
        Viewport   0 0
        Depth      16
        Modes       "1024x768" "800x600" "640x480"
    EndSubSection
    SubSection     "Display"
        Viewport   0 0
        Depth      24
        Modes       "1024x768 @ 75Hz" "1024x768 @ 70Hz" "1024x768 @ 60Hz" "800x600 @ 85Hz" "800x600 @ 75Hz" "800x600 @
72Hz" "800x600 @ 60Hz"

```

Chapter 4

System Configuration

This chapter describes Basic Input Output System (BIOS) configuration.

When you install the NEC Express5800/ft series for the first time or install/remove optional devices, thoroughly read this chapter for better understanding and correct setups.

SYSTEM BIOS –SETUP–

The SETUP utility is provided to make basic hardware configuration for the server. This utility is pre-installed in the flash memory of the server and ready to run.

The server is configured with the correct parameters using the SETUP utility and shipped in the best conditions. Thus, you do not need to use the SETUP utility in most cases. However, you might wish to use the SETUP utility in the cases described below.

IMPORTANT:

- The SETUP utility is intended for system Administrator use only.
 - The SETUP utility allows you to set a password. The server is provided with two levels of password: Supervisor and User. With the Supervisor password, you can view and change all system parameters of the SETUP utility. With the User password, system parameters available for viewing and changing are limited.
 - Do not set any password before installing the OS.
 - The server contains the latest version of the SETUP utility. Dialog boxes appearing on your SETUP utility, thus, may differ from descriptions in this User's Guide. If you find anything unclear, see the online help or ask your sales agent.
-

Starting SETUP Utility

Powering on the server starts POST (Power On Self-Test) and displays its check results. If the NEC logo is displayed, press **Esc**.

After a few seconds, either of the following messages appears at bottom left on the screen depending on your system configuration.

Press <F2> to enter SETUP

Press <F2> to enter SETUP or Press <F12> to boot from Network

You may see either of the following messages at bottom left on the screen when POST terminates.

Press <F1> to resume, <F2> to SETUP

Press **F2** to start the SETUP utility and display its Main menu.

If you have previously set a password with the SETUP utility, the password entry screen appears. Enter the password.

Enter password:[]

Up to three password entries will be accepted. If you fail to enter the password correctly for three consecutive times, the server halts. (You can no longer proceed.) Power off the server.

TIPS:

The server is provided with two levels of password: Supervisor and User. With the Supervisor password, you can view and change all system configurations. With the User password, the system configurations you can view or change are limited.

Description of On-Screen Items and Key Usage

Use the following keyboard keys to work with the SETUP utility. (Key functions are also listed at the bottom of the screen.)

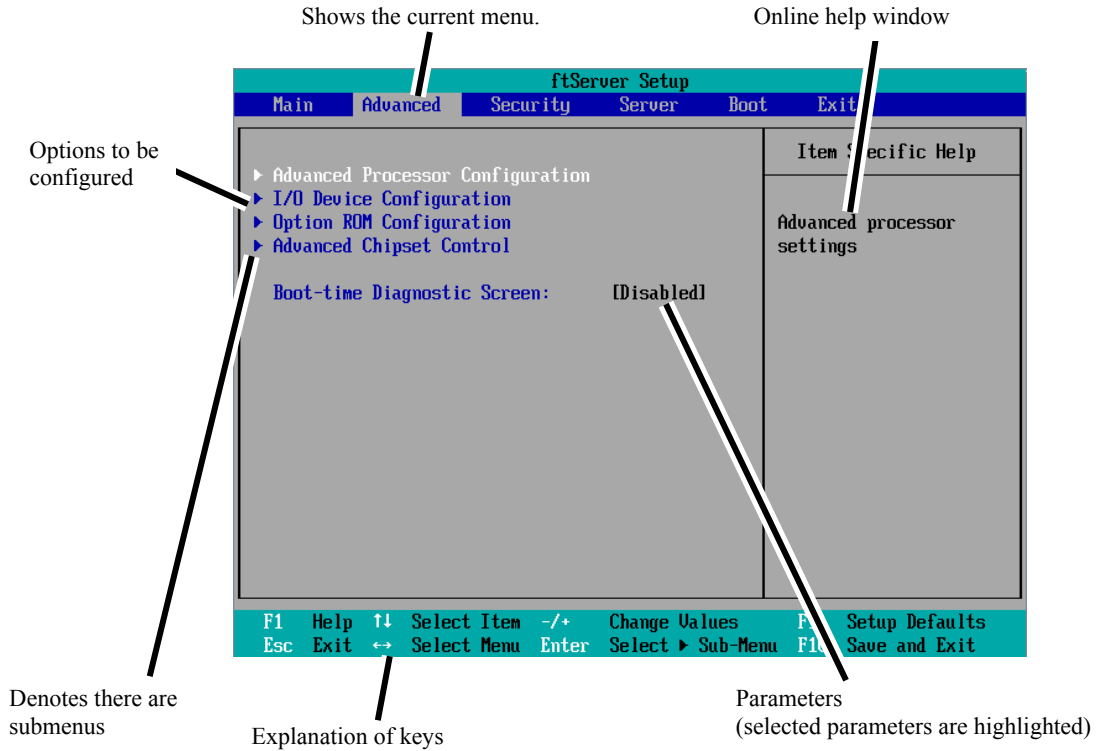

- Cursor** (↑, ↓): Selects an item on the screen. The highlighted item is currently selected.
- Cursor** (←, →): Selects the Main, Advanced, Security, System Hardware, Boot, or Exit menu.
- : Changes the value (parameter) of the selected item to the previous value.
- +**: Changes the value (parameter) of the selected item to next value.
- Enter**: Displays a submenu or chooses the selected parameter.
- Esc**: Displays the previous screen.
- F1**: Press **F1** when you need help on SETUP operations. The help screen for SETUP operations appears. Press **Esc** to return to the previous screen.

F9:

Shows the following:

Setup Confirmation
Load default configuration now?
[Yes] [No]

If you select “Yes” and then press the **Enter** key, all items in the setup are set to default values. If you select “No” and then press either the **Enter** or **Esc** key, the status before pressing the **F9** key is restored.

F10:

Shows the following:

Setup Confirmation
Save Configuration changes and exit now?
[Yes] [No]

If you select “Yes” and then press the **Enter** key, the setup will complete with all changes you have made saved. If you select “No” and then press either the **Enter** or **Esc** key, the status before pressing the **F10** key is restored.

Configuration Examples

The following describes examples of configuration required to use software-link features or for system operations.

UPS

To link power supply with the UPS

- To power on the server when power is supplied from the UPS
Select [Server] - [AC-LINK] - [Power On].
- To keep the server off-powered even when power is supplied from the UPS if the POWER switch was used to power off
Select [Server] - [AC-LINK] - [Last State].
- To keep the server off-powered even when power is supplied from the UPS
Select [Server] - [AC-LINK] - [StayOff].

Keyboard

To set Num Lock

Select [Advanced] - [I/O Device Configuration] - [NumLock]

Security

To set passwords on the BIOS level

Select [Security] - [Set Supervisor Password] and enter a password.

Select [Security] - [Set User Password] and enter a password.

Set Supervisor password first, then User password.

Optional PCI-related devices

To enable Option ROM of the PCI card (option) installed on the server

Select [Advanced] - [Option ROM Configuration] - [PCI Slot n (...)] - [Enabled].

n: Slot number to install the board

Boot

To change the boot order of devices connected to the server

Select [Boot] and specify the boot order.

To display POST check results

Select [Advanced] - [Boot-time Diagnostic Screen] - [Enabled].

You can also press **Esc** while the NEC log is on the screen to display POST check results.

To control from the HW console

- Remote operation via Serial

Select [Server] - [Console Redirection], and make necessary settings.

Remote Wakeup

To enable remote wake on LAN

Select from LAN: [Advanced] - [Advanced Chipset Control] - [Wake on LAN] - [Enabled].

Memory

To check the installed memory (DIMM) status:

Select [Advanced] - [System Memory] and [Extended Memory] and check the status indications.

Saving the Configuration Data

To save the BIOS configuration data

Select [Exit] - [Exit Saving Changes]

To discard changes to the BIOS configuration data

Select [Exit] - [Exit Discarding Changes]

To restore the default BIOS configuration data (the data may differ from the factory preset)

Select [Exit] - [Load Setup Defaults].

Menu and Parameter Descriptions

The SETUP utility has the following six major menus:

- Main
- Advanced
- Security
- Server
- Boot
- Exit

To configure detailed settings of functions, select a submenu from the above menus. Below describes configurable functions and parameters and the factory settings displayed in the screen for each menu.

Main

Start the SETUP utility to display the Main menu.

When you select a menu with the “▶” mark and press the **Enter** key, its submenu appears.

<Example>

ftServer Setup		
Main	Advanced Security Server Boot Exit	
System Time: [13]:18:41]	Item Specific Help <Tab>, <Shift-Tab>, or <Enter> selects field.	
System Date: [06/22/2009]		
CPU Speed 2930 MHz		
Physical CPUs 1		
Logical CPUs 8		
System Memory 633 KB		
Extended Memory 2047 MB		
Cache Ram 1024 KB		
L3 Cache 8192 KB		
F1 Help ↑↓ Select Item -/+ Change Values F9 Setup Defaults		
Esc Exit ↔ Select Menu Enter Select ▶ Sub-Menu F10 Save and Exit		

Available options in the Main and descriptions are listed below.

Option	Parameter	Description
System Time	HH:MM:SS	Specify the system time.
System Date	MM/DD/YYYY	Specify the system date.
CPU Speed	XXXX MHz	Displays the processor clock frequency.
Physical CPUs	X	Displays the number of processor installed.
System Memory	XXXX KB	Displays the size of system memory.
Extended Memory	XXXX MB	Displays the size of extended memory.
Cache Ram	XXXX KB	Displays the capacity of LS cache.
L3 Chache	XXXX KB	Displays the capacity of L3 cache.

IMPORTANT:

Check and adjust the system clock before operation in the following conditions.

- After transporting the equipment
- After storing the equipment
- After the equipment halt under the conditions which is out of the guaranteed environment conditions (Temperature: 10 to 35°C, Humidity: 20 to 80%).

Check the system clock once in a month. It is recommended to operate the system clock using a time server (NTP server) if it is installed on the system which requires high level of time accuracy. If the system clock goes out of alignment remarkably as time goes by, though the system clock adjustment is performed, contact your sales agent.

Advanced

Move the cursor onto “Advanced” to display the Advanced menu.

There is no configurable item on the Advanced menu screen below. Display each sub menu and make settings on the sub menu screen. Select an option with the “▶” mark and press **Enter** to display its submenu.



See the table below for setup options on the screen.

Option	Parameter	Description
Boot-time Diagnostic Screen	[Disabled] Enabled	Specify whether to display the Power On Self-Test (POST) screen at start-up. If “Disabled” is selected, the NEC logo appears while POST is in progress. (To display POST check results, press Esc .)

[]: factory default

Advanced Processor Configuration

When you select “Advanced Processor Configuration” in the Advanced menu, the following screen appears.

ftServer Setup	
Advanced	
Advanced Processor Configuration	Item Specific Help
Hyper-Threading Technology: [Enabled]	Disables/enables Intel (R) Hyper-Threading Technology.
Execute Disable Bit: [Enabled]	
Virtualization Technology: [Enabled]	
Hardware Prefetcher: [Enabled]	
Adjacent Cache Line Prefetch: [Enabled]	
F1 Help ↑↓ Select Item -/+ Change Values F9 Setup Defaults Esc Exit ↔ Select Menu Enter Select ▶ Sub-Menu F10 Save and Exit	

Refer to the table below for information on options.

Option	Parameter	Description
Hyper-Threading Technology	Disabled [Enabled]	Enables to function one physical processor as two logical processors. Configurable only when the processor that supports this function is mounted.
Execute Disable Bit	Disabled [Enabled]	Specify whether or not to enable Execute Disable Bit feature.
Virtualization Technology	Disabled [Enabled]	Specify whether or not to enable Intel Virtualization Technology feature.
Hardware Prefetcher	Disabled [Enabled]	Specify whether or not to enable Hardware Prefetcher.
Adjacent Cache Line Prefetch	Disabled [Enabled]	Specify whether or not to enable optimization of access to cache from memory.

[]: factory default

I/O Device Configuration

When you select “I/O Device Configuration” in the Advanced menu, the following screen appears. If you select a menu with the “▶” mark and press **Enter**, its submenu appears.

ftServer Setup		
Advanced		
I/O Device Configuration	Item Specific Help	
Serial Port 1:	[Enabled]	Configure Serial Port 1 using options: [Disabled] No configuration [Enabled] User configuration [Auto] BIOS or OS chooses configuration
Base I/O address:	[3F8/IRQ 4]	
Serial Port 1 Connection:	[Serial Connector]	
Serial Port 2:	[Enabled]	
Base I/O address:	[2F8/IRQ 3]	
Keyboard Features:		
NumLock:	[Off]	
F1 Help ↑↓ Select Item -/+ Change Values F9 Setup Defaults Esc Exit ↔ Select Menu Enter Select ▶ Sub-Menu F10 Save and Exit		

Refer to the table below for information on options.

Option	Parameter	Description
Serial Port 1	Enabled [Disabled] Auto	Specify whether or not to enable Serial Port 1.
Base I/O address	[3F8/IRQ4] 2F8/IRQ3 3E8/IRQ4 2E8/IRQ3	Specify the I/O address and IRQ of Serial Port 1.
Serial Port 1 Connection	[Serial Connector] Internal Modem	Specify Serial Connector or Internal Modem for Serial Port 1 connection.
Serial Port 2	Enabled [Disabled] Auto	Specify whether or not to enable Serial Port 2.

Base I/O address	3F8/IRQ4 [2F8/IRQ3] 3E8/IRQ4 2E8/IRQ3	Specify the I/O address and IRQ of Serial Port 2.
Keyboard Features		Display only.
NumLock	AUTO On [Off]	Specify whether or not to enable NumLock at system startup.

[]: factory default

Option ROM Configuration

When you select “Option ROM Configuration” in the Advanced menu, the following screen appears.

ftServer Setup	
Advanced	
Option ROM Configuration	Item Specific Help
Embedded SAS Option ROM: [Enabled] Embedded PXE#1 Option ROM: [Enabled] Embedded PXE#2 Option ROM: [Enabled]	Enables Embedded SAS Option ROM to boot from the device. Default state: ENABLED
F1 Help ↑↓ Select Item -/+ Change Values F9 Setup Defaults Esc Exit ↔ Select Menu Enter Select ▶ Sub-Menu F10 Save and Exit	

Refer to the table below for information on options.

Option	Parameter	Description
PCI Slot 1 Option ROM	Enabled [Disabled]	If “Enabled” is selected, the extended ROM of the PCI card installed on PCI Slot 1 is initialized. Note: this option is displayed only when a PCI card is installed.
PCI Slot 2 Option ROM	Enabled [Disabled]	If “Enabled” is selected, the extended ROM of the PCI card installed on PCI Slot 2 is initialized. Note: this option is displayed only when a PCI card is installed.
PCI Slot 3 Option ROM	Enabled [Disabled]	If “Enabled” is selected, the extended ROM of the PCI card installed on PCI Slot 3 is initialized. Note: this option is displayed only when a PCI card is installed.
PCI Slot 4 Option ROM	Enabled [Disabled]	If “Enabled” is selected, the extended ROM of the PCI card installed on PCI Slot 4 is initialized. Note: this option is displayed only when a PCI card is installed.
Embedded SAS Option ROM	[Enabled] Disabled	If “Enabled” is selected, SAS extended ROM embedded in the motherboard is initialized.

Embedded PXE#1 Option ROM	[Enabled] Disabled	If "Enabled" is selected, the extended ROM of LAN #1 embedded in the motherboard is initialized.
Embedded PXE#2 Option ROM	[Enabled] Disabled	If "Enabled" is selected, the extended ROM of LAN #2 embedded in the motherboard is initialized.

[]: factory default

Advanced Chipset Control

When you select "Advanced Chipset Control" in the Advanced menu, the following screen appears.

ftServer Setup	
Advanced	
Advanced Chipset Control	Item Specific Help
Multimedia Timer: [Disabled]	Enables/disables Multimedia Timer (HPET) .
Intel(R) I/OAT: [Disabled]	
Intel(R) VT-d: [Disabled]	
Wake On LAN: [Enabled]	
F1 Help ↑↓ Select Item -/+ Change Values F9 Setup Defaults Esc Exit ↔ Select Menu Enter Select ► Sub-Menu F10 Save and Exit	

Refer to the table below for information on options.

Option	Parameter	Description
Multimedia Timer	[Disabled] Enabled	Specify whether or not to enable timer to correspond to multimedia.
Intel(R) I/OAT	[Enabled] Disabled	Specify whether or not to enable Intel(R) I/OAcceleration Technology feature.
Intel(R) VT-d	[Disabled] Enabled	Specify whether or not to enable "Intel(R) Virtualization Technology for Directed I/O" that Intel Chipset offers.
Wake On LAN	[Enabled] Disabled	Specify whether or not to enable network remote power-on feature.

[]: factory default

IMPORTANT:

Under Wake On LAN environment

On the OS, go to [Start] - [Management Tool] - [Computer Management] and select the Device Manager. Double click [Stratus emb-EB 2-Port Gigabit Adapter #n] under the network adapter, then select the following option from [Power Management] tab:

Wake On Magic Packet from power off state

If Magic Packet corresponding to the MAC address of CPU/IO module on either side is issued, the system can be started. However, the system can also be started even when one side of the CPU/IO modules fails if Magic Packet is issued for both CPU/IO modules.

Security

Move the cursor onto “Security” to display the Security menu.

ftServer Setup					
Main	Advanced	Security	Server	Boot	Exit
Supervisor Password Is: Unset User Password Is: Unset Set Supervisor Password [Enter] Set User Password [Enter] Password on boot: [Disabled] ▶ Security Chip Configuration					Item Specific Help Supervisor Password controls access to the setup utility.
F1	Help	↑↓	Select Item	-/+	Change Values
F9	Setup Defaults				
Esc	Exit	↔	Select Menu	Enter	Select ▶ Sub-Menu
F10	Save and Exit				

Select “Set Supervisor Password” or “Set User Password” and press **Enter** to display the following pop-up screen. The screen below shows when “Set Supervisor Password” is selected.

Set a password on this pop-up screen. Enter a password of up to seven alphanumeric characters and symbols from the keyboard.

ftServer Setup		
Main	Advanced	Security
Supervisor Password Is:	Unset	Item Specific Help
User Password Is:	Unset	
Set Supervisor Password	[Enter]	Supervisor Password controls access to the setup utility.
Set User Password	[Enter]	
Password on boot		
▶ Security Chip Co		
<div style="border: 1px solid black; background-color: #000080; color: white; padding: 5px;"> <p style="text-align: center;">Set Supervisor Password</p> <p>Enter New Password []</p> <p>Confirm New Password []</p> </div>		
Enter Accepts Esc Clears		

IMPORTANT:

- User password setup is not available before Supervisor password setup.
- Do not set any password before installing the OS.
- If you forget your password, contact your sales agent.

See the table below for setup options on the screen.

Option	Parameter	Description
Supervisor Password Is	[Unset] Set	Indicates Supervisor password setup status (view only).
User Password is	[Unset] Set	Indicates User password setup status (view only).
Set Supervisor Password	[Enter]	Press Enter to display the supervisor password entry screen. This option is available only when you log into the SETUP utility with the supervisor password.
Set User Password	[Enter]	Press Enter to display the user password entry screen. With a user password, accessing the SETUP menus is restricted.
Password on boot	[Disabled] Enabled	Specify whether to request a password entry at boot-up. User password setup is required beforehand.

[]: factory default

IMPORTANT:

If you have logged in SETUP by using the Supervisor Password, you can check and change all settings. If you have logged in SETUP by using User Password, you can see the settings but cannot make changes on the settings except System Time, System Date and User Password of Main.

Server

Move the cursor onto [Server] to display the Server menu.

The following describes options you can configure in the Server menu and their functions. Select an option with the “▶” mark and press **Enter** to display its submenu.

Refer to the table below for information on options.

ftServer Setup					
Main	Advanced	Security	Server	Boot	Exit
▶ System Management ▶ Console Redirection ▶ CRU0 BMC LAN Configuration ▶ CRU1 BMC LAN Configuration ▶ Event Log Configuration ▶ Monitoring Configuration Post Error Pause: [Enabled] AC-LINK: [Last State] Power ON Delay Time: [5]				Item Specific Help Additional setup menu to view server management features.	
F1 Help ↑↓ Select Item -/+ Change Values F9 Setup Defaults Esc Exit ↔ Select Menu Enter Select ▶ Sub-Menu F10 Save and Exit					

Option	Parameter	Description
Post Error Pause	Disabled [Enabled]	Set whether or not to pause POST at the end of POST if an error has occurred during POST execution.
AC LINK	Stay Off [Last State] Power On	Specify the AC LINK feature by selecting the status of the power supply unit of the server when the AC power supply restarts. (See the following table for details.) When “Power On” and “Last State” are set, the system can be started after waiting for both CPU/IO modules to be mounted up to 180 seconds in addition to the delay time of “Power On Delay Time”.
Power ON Delay Time	[180]-255(s)	Set the DC ON delay time if AC LINK is set to “Power On” or “Last State” (unit: second).

[]: factory default

The table below lists how selections for “AC LINK” determine the power status of the server when the power supply to the server restarts.

State before powered off	Parameter		
	Stay Off	Last State	Power On
In service	Off	On	On
Out of service (DC power: Off)	Off	Off	On
Forced shutdown *	Off	Off	On

* Pressing the POWER switch for over four seconds shuts down the power to the server.

System Management

Select “System Management” on the Server menu and press **Enter** to display the following screen.

(Example)

ftServer Setup	
Server	
System Management	Item Specific Help
BIOS Version: 4.0:31 Board Part #: 243-633638 Board Serial #: 0000000101 System Part #: N8800-144 System Serial #: 0000000101 Chassis Part #: 243-000000-001 Chassis Serial #: 01 BMC Device ID: 40 BMC Device Rev: 01 BMC Firmware Rev: 01.11 SDR Rev: SDR Version 01.02 PIA Rev: 01.05 ASIC Rev: 0002700239 SMM Rev: 21	All items on this menu cannot be modified in user mode. If any items require changes, please consult your system Supervisor.
F1 Help ↑↓ Select Item -/+ Change Values Esc Exit ↔ Select Menu Enter Select ▶ Sub-Menu	F9 Setup Defaults F10 Save and Exit

See the table below for setup options on the screen.

Option	Parameter	Description
BIOS Version	—	Displays the BIOS version.
Board Part Number	—	Displays the board information.
Board Serial Number	—	Displays the board information.
System Part Number	—	Displays the system information.
System Serial Number	—	Displays the system information.
Chassis Part Number	—	Displays the chassis information.
Chassis Serial Number	—	Displays the chassis information.
BMC Device ID	—	Displays the BMC information.
BMC Device Revision	—	Displays the BMC information.
BMC Firmware Revision	—	Displays the BMC information.
SDR Revision	—	Displays the revision of SDR (sensor device information).
PIA Revision	—	Displays the PIA (plat form information) revision.
ASIC Rev	—	Displays the firmware information of the fault-tolerant chipset.
SMM Rev	—	Displays the firmware information of System Management.
System MAC Address	—	Displays MAC Address of the system.

[]: factory default

Console Redirection

Select “Console Redirection” on the Server menu and press **Enter** to display the following screen.

ftServer Setup		Server	
Console Redirection		Item Specific Help	
Com Port Address:	[Disabled]	If enabled, it will use a port on the motherboard.	
Baud Rate:	[19.2K]		
Console Type:	[PC ANSI]		
Flow Control:	[CTS/RTS]		
Console connection:	[Direct]		
Continue C.R. after POST:	[Off]		
F1 Help ↑↓	Select Item -/+	Change Values	F9 Setup Defaults
Esc Exit ↔	Select Menu Enter	Select ▶ Sub-Menu	F10 Save and Exit

See the table below for setup options on the screen.

Option	Parameter	Description
Com Port Address	[Disabled] Serial Port1 Serial Port2	Select a serial port.
Baud Rate*	9600 [19.2K] 38.4K 57.6K 115.2K	Select a port rate used for the interface with a hardware console to be connected.
Console Type*	VT100 VT100, 8bit PC-ANSI, 7bit [PC-ANSI] VT100+ VT-UTF8	Select a console type.
Flow Control*	None XON/XOFF [CTS/RTS]	Select a flow control method.
Console Connection	[Direct] Via modem	Select a connector.
Continue C.R. after POST	[Off] On	Specify whether or not to continue Console Redirection after OS is loaded.

[]: factory default

CRUx BMC LAN Configuration Submenu

Select “CRUx BMC LAN Configuration” on the Server menu and press **Enter** to display the following screen.

ftServer Setup		
Server		
CRU0 BMC LAN Configuration	Item Specific Help	
LAN Connection Type: [Auto Negotiation]	Set a LAN connection type on your management LAN.	
IP Address: [192.168.001.001]		
Subnet Mask: [255.255.255.000]		
Default Gateway: [000.000.000.000]		
DHCP: [Disabled]		
Web Interface		
HTTP: [Disabled]		
HTTP Port Number: [80]		
HTTPS: [Disabled]		
HTTPS Port Number: [443]		
Command Line Interface		
Telnet: [Disabled]		
Telnet Port Number: [23]		
F1 Help ↑↓ Select Item -/+ Change Values F9 Setup Defaults Esc Exit ↔ Select Menu Enter Select ▶ Sub-Menu F10 Save and Exit		

See the table below for setup options on the screen.

Option	Parameter	Description
LAN Connection Type	[Auto Negotiation] 100Mbps Full Duplex 100Mbps Half Duplex 10Mbps Full Duplex 10Mbps Half Duplex	Set the connection type of the Management LAN.
IP Address	[192.168.001.001]	Set the IP address for the Management LAN.
Subnet Mask	[255.255.255.000]	Set the subnet mask for the Management LAN.
Default Gateway	[000.000.000.000]	Set the gateway for the Management LAN.
DHCP	[Disabled] Enabled	Set "Enabled" to automatically acquire an IP address from the DHCP server. Set "Disabled" when you specify the IP address.
Web Interface	—	—
HTTP	[Disabled] Enabled	Set "Enabled" if you use communication via HTTP, a web interface.
HTTP Port Number	[80]	Set the TCP port number for the Management LAN to communicate via HTTP.
HTTPS	[Disabled] Enabled	Set "Enabled" if you use communication via HTTPS, a web interface.
HTTPS Port Number	[443]	Set the TCP port number for the Management LAN to communicate via HTTPS.
Command Port Number	—	—
Telnet	[Disabled] Enabled	Set "Enabled" when you use Telnet-connected communication as the command line interface communication.
Telnet Port Number	[23]	Set the TCP port number when you use Telnet-connected communication.
SSH	[Disabled] Enabled	Set the TCP port number when you use SSH-connected communication as the command line interface.
SSH Port Number	[22]	Set the TCP port number when you use SSH-connected communication.
Clear BMC Configuration	[Enter]	Click [Enter] and then select [Yes] to initialize BMC Configuration.

[]: factory default

Event Log Configuration

Select “Event log Configuration” on the Server menu and press **Enter** to display the following screen.

ftServer Setup		
		Server
Event Log Configuration	Item Specific Help	
Clear Online Event Logs: [Press Enter]	The system event log will be cleared if selecting "YES".	
Clear Offline Event Logs: [Press Enter]		
F1 Help ↑↓ Select Item -/+ Change Values F9 Setup Defaults Esc Exit ↔ Select Menu Enter Execute Command F10 Save and Exit		

See the table below for setup options on the screen.

Option	Parameter	Description
Clear Online Event Logs	[Press Enter]	To clear event logs of the working module, press the Enter key and select “Yes.”
Clear Offline Event Logs	[Press Enter]	To clear event logs of the stand-by module, press the Enter key and select “Yes.”

Monitoring Configuration

Select “Monitoring Configuration” on the Server menu and press **Enter** to display the following screen.

ftServer Setup		
Server		
Monitoring Configuration		Item Specific Help
FRB-2 Timer:	[Enabled]	Disables/enables the FRB-2 Timer.
PCI Enumeration Monitoring:	[Enabled]	
PCI Enumeration Monitoring Timeout:	[180]	
Option ROM Scan Monitoring:	[Enabled]	
Option ROM Scan Monitoring Timeout:	[300]	
OS Boot Monitoring:	[Enabled]	
OS Boot Monitoring Timeout:	[600]	
POST Pause Monitoring:	[Enabled]	
POST Pause Monitoring Time-out:	[180]	
F1 Help ↑↓	Select Item -/+	Change Values
F9	Setup Defaults	
Esc Exit ↔	Select Menu Enter	Select ▶ Sub-Menu
F10	Save and Exit	

Option	Parameter	Description
FRB-2 timer	Disabled [Enabled]	Select whether or not to enable the FRB-2 timer.
PCI Enumeration Monitoring	Disabled [Enabled]	Select whether or not to enable the function to monitor PCI Device scan.
PCI Enumeration Monitoring Timeout	60-[180]-1200	Set the timeout for PCI Device scan. (unit: second)
Option ROM Scan Monitoring	Disabled [Enabled]	Select whether or not to enable the function to monitor the extended ROM scan.
Option ROM Monitoring Timeout	60-[300]-1200	Set the timeout of the extended ROM scan. (unit: second)
OS Boot Monitoring	Disabled [Enabled]	Select whether or not to enable the function to monitor OS boot-up. If you are starting up from an OS with no NEC ESMPRO Agent installed, disable this option.
OS Boot Monitoring Timeout	60-[600]-1200	Set the timeout at OS boot-up. (unit: second)
POST Pause Monitoring	Disabled [Enabled]	Set whether or not to enable the POST monitoring function during boot pause. (unit: second)
POST Pause Monitoring Time-out	60-[180]-1200	Set the time for POST monitoring during boot pause. (unit: second)

[]: factory default

Boot

Move the cursor onto “Boot” to display the Boot menu.

The server searches for the boot device according to the order specified in this menu and use the software to boot the system if found.

ftServer Setup					
Main	Advanced	Security	Server	Boot	Exit
1: USB CDROM: MATSHITA UJDA782 DVD/CDRW 2: USB FDC: 3: USB KEY: 4: USB HDD: 5: PCI SCSI: #0500 ID00 LUN0 SEAGATE S 6: PCI BEV: IBA GE Slot 0B00 v1322 7: PCI BEV: IBA GE Slot 0B01 v1322 8:					Item Specific Help Keys used to view or configure devices: Up and Down arrows select a device. <+> and <-> moves the device up or down. <x> exclude or include the device to boot.
F1	Help	↑↓	Select Item	-/+	Change Values
F9	Setup Defaults				
Esc	Exit	↔	Select Menu	Enter	Select ► Sub-Menu
F10	Save and Exit				

See the table below for options on the screen.

Displayed Item	Device
USB CDROM	USB CD-ROM Drive
USB FDC	USB Floppy Disk Drive
USB KEY	USB device such as USB Flash Memory
USB HDD	USB Hard Disk Drive
PCI SCSI	Standard-equipped Hard Disk Drive
PCI BEV	BA GE Slot xxxx : standard-equipped LAN

[]: factory default

1. BIOS displays the pertinent device information when it detects a bootable device. You need to register the devices in order to boot from the arbitrary devices displayed on the menu (up to 8 devices are registrable).
2. You can register/deregister the selected devices as the boot device after you select the device and press **X** key. If you have already registered up to 8 bootable devices, you can no more register even when you press **X** key. Deregister any device that you do not need from the menu and retry the registration.
3. You can change the boot device order using \uparrow or \downarrow and + or -. Move the cursor to select the device by \uparrow or \downarrow , and then change the priority using + or -.

Exit

Move the cursor onto “Exit” to display the Exit menu.

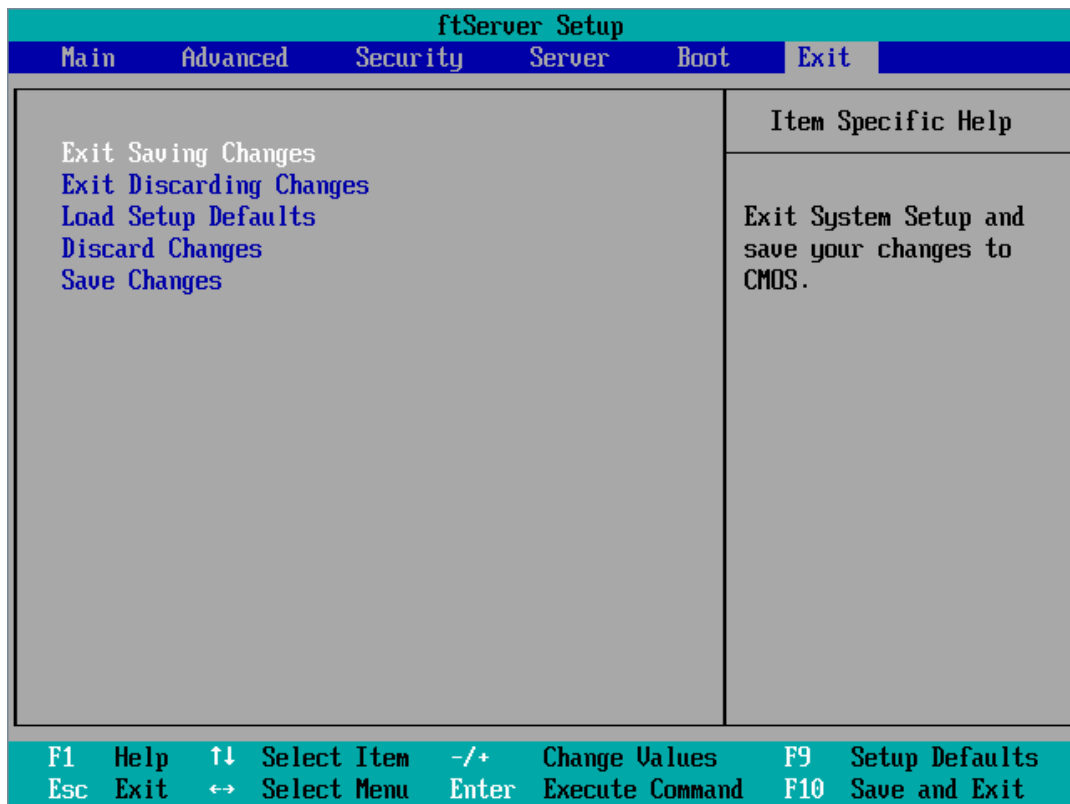

The following describes each option on the Exit menu:

Exit Saving Changes

Select this option to save the current configuration data into the CMOS (non-volatile memory) and exit the SETUP utility.

Select “Exit Saving Changes” to display the screen below. Select “Yes” to save the current configuration data into the CMOS (non-volatile memory) and exit the SETUP utility. The server will automatically restart the system.

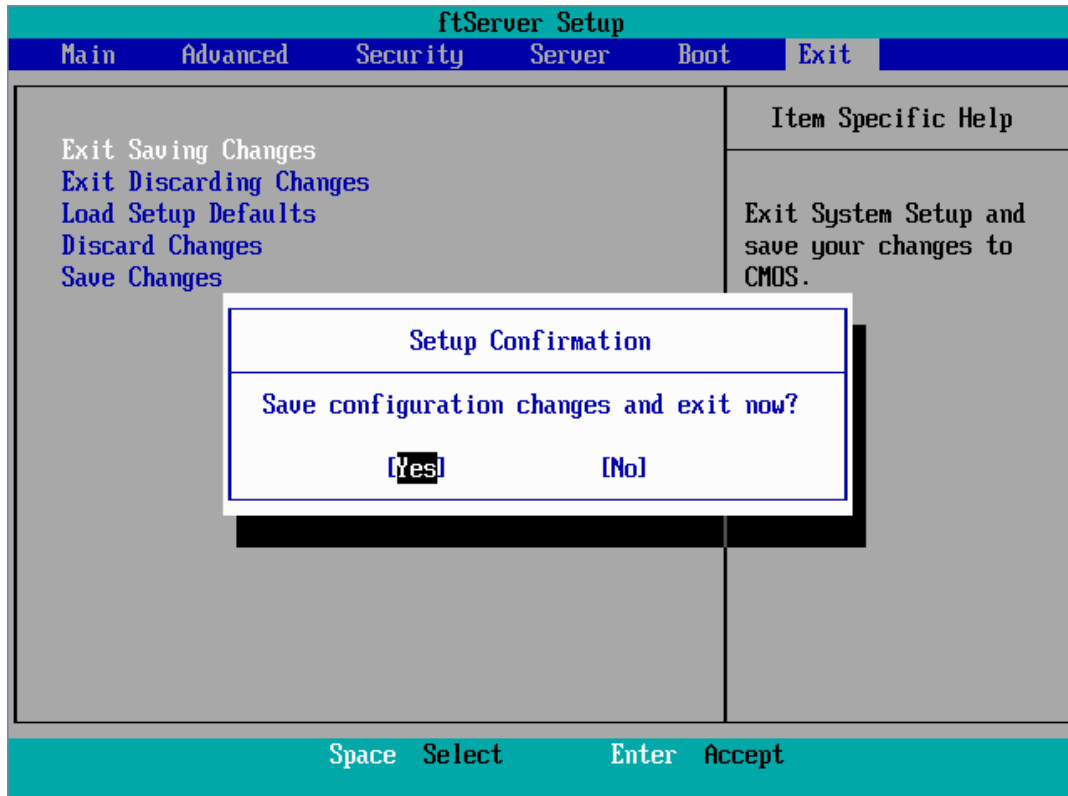

Exit Discarding Changes

Select this option to exit the SETUP utility without saving the current configuration data into the CMOS (non-volatile memory).

If you select “Yes” here, the “SETUP Warning” dialogue box appears.

If you select “No” in the “SETUP Warning” dialogue box, you can exit SETUP without saving the changes you have made.

If you select “Yes” in the dialogue box, you can exit SETUP with the changes you have made saved in CMOS. The server reboots automatically.

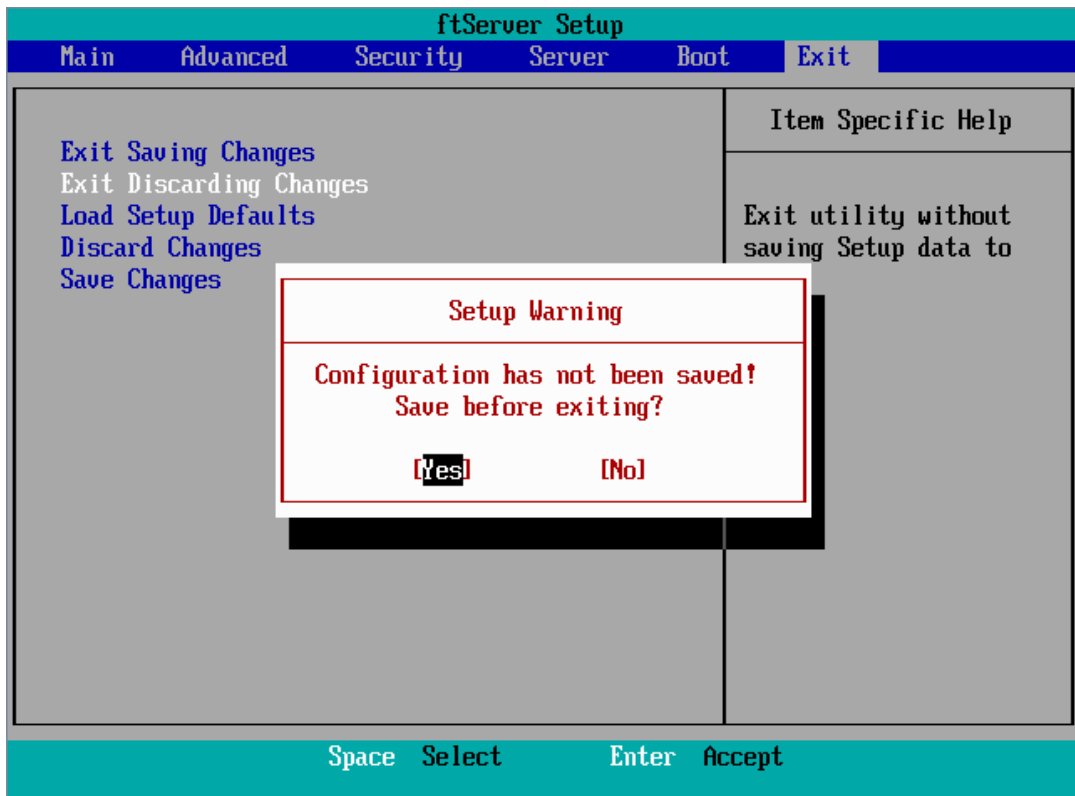

Load Setup Defaults

Select this option if you want to reset all values in SETUP to default (factory-set values). When you select Load Setup Defaults, the dialogue box as shown below appears.

If you select “Yes” in the dialogue box, default values are restored. If you select “No”, you will see the Exit menu screen.

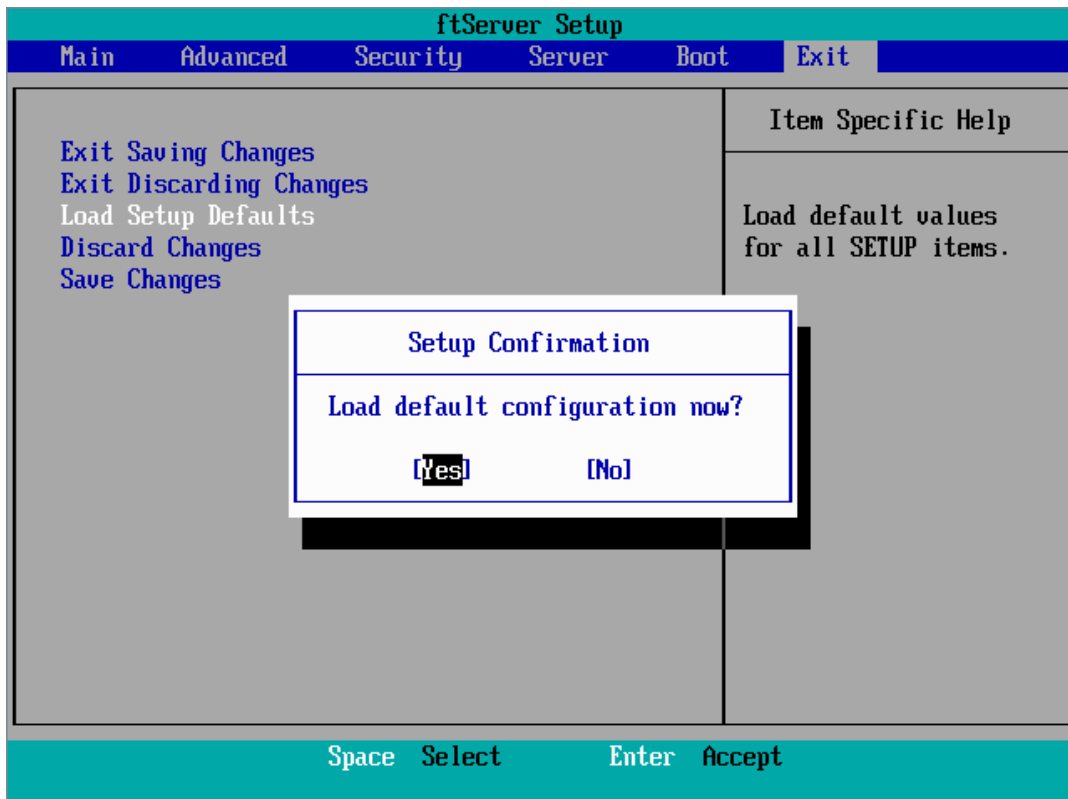

Discard Changes

Select this option if you want to restore previous values before saving values in CMOS. When you select “Discard Changes”, you will see the dialogue box as shown below.

If you select “Yes” in the dialogue box, changes you have made are discarded and previous settings are restored.

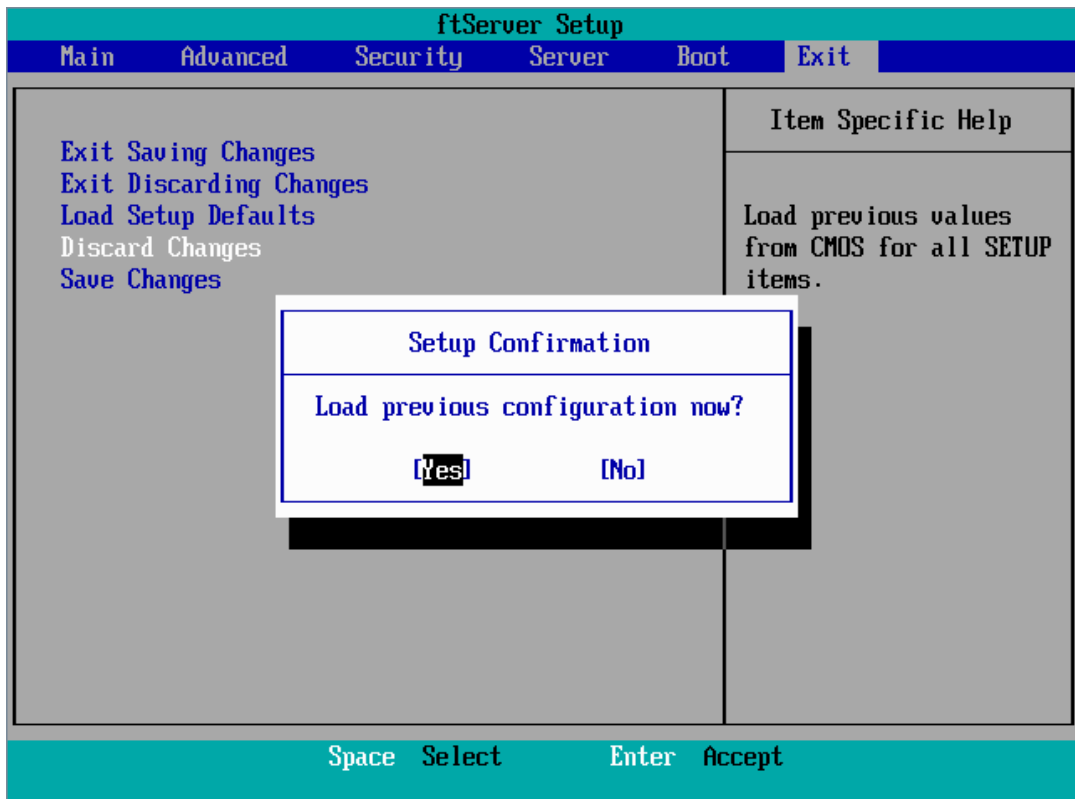

IMPORTANT:

The default value and the factory default value differ partially. If you want to bring the value back to the default, verify all the value you want to make changes.

Save Changes

Select this option if you want to save changes you have made in CMOS (non-volatile memory) without exiting SETUP. When you select the Save Changes, you will see the dialogue box as shown below.

If you select “Yes” in the dialogue box, changes you have made are saved in CMOS (non-volatile memory).

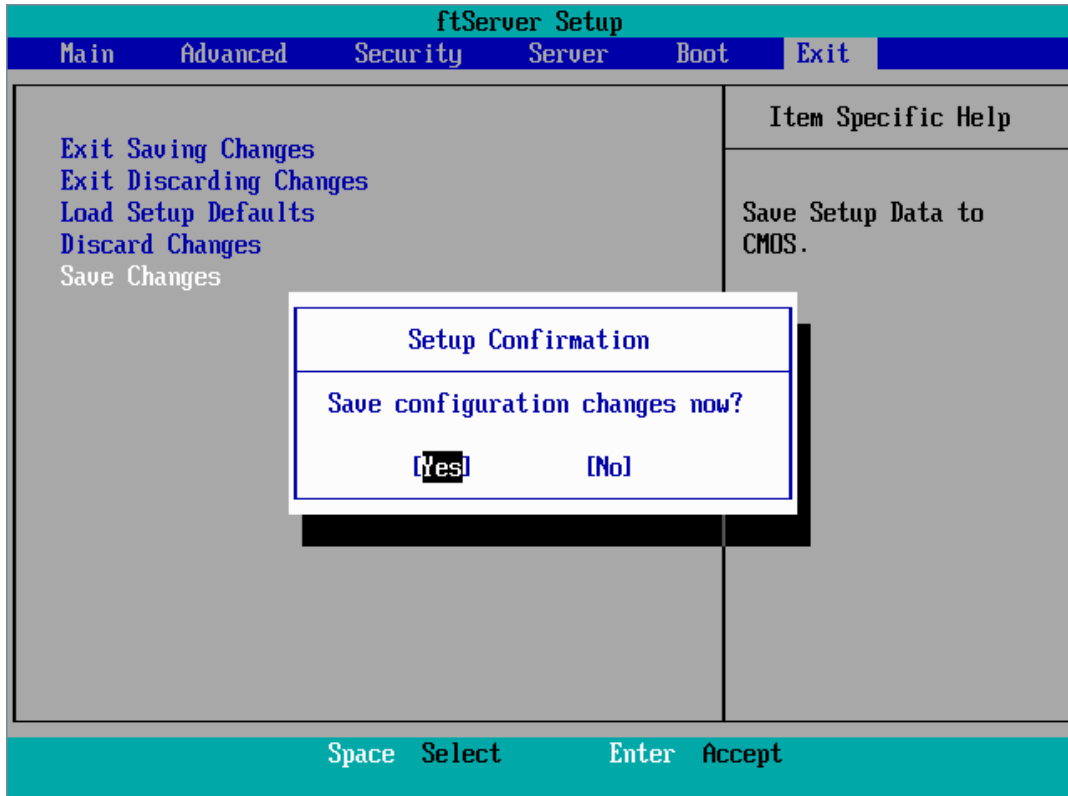

SAS BIOS – SAS Configuration Utility –

SAS Configuration utility makes settings of the built-in SAS controller. You can start it up by simple key operation during POST execution without using any special startup disk.

IMPORTANT:

- Because the server is installed with the latest version of the utility, your screen display may be different from the one described in this guide. For information on options different from those described in this guide, refer to the online help or ask your service agent.
 - When you start this utility, select [Server], [Monitoring Configuration], [Option ROM Scan Monitoring], and [Disabled]. If [Enabled] is selected, system may reboot while you are making settings. However, set [Option ROM Scan Monitoring] to [Enabled] after making settings.
 - This utility is set for the CPU/IO module of the primary side. When you configure the CPU/IO module of the secondary side, first power off the server, plug out and plug in the AC code of the primary side. Then start the server.
 - Do not change the settings on each utility menu, as doing so causes failure and malfunction of this server.
-

Starting the SAS Configuration utility

The following section describes the procedures to start the SAS/ Configuration utility.

1. Power on the server.

The following message appears on the screen during POST execution.



```
LSI Corporation MPT SAS BIOS
MPTBIOS-6.28.00.00 (2009.02.03)
Copyright 2000-2009 LSI Corporation.

Press Ctrl-C to start LSI Corp Configuration Utility...
```

2. Press and hold down the **Ctrl** key and press the **C** key.

The SAS Configuration utility starts up with the “Adapter List” menu displayed.

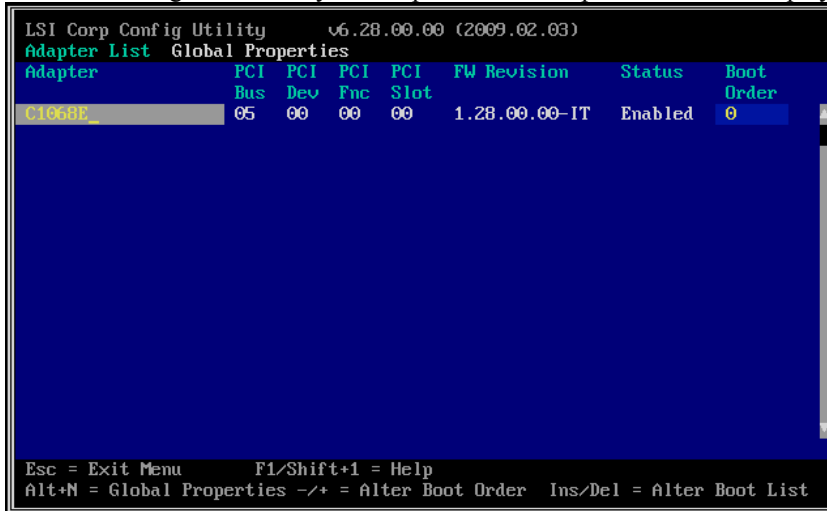

Quitting the SAS Configuration utility

The following section describes the procedures to quit the SAS/ Configuration utility.

1. Keep pressing **ESC** key until the “Adapter List” menu appears.
If you changed each menu setting of “SAS Configuration Utility,” a message appears to prompt whether you want to save the changes made.
Select the item you want and press **Enter** key when the message is displayed.

```

xxxxxxxx xxxxxxxx changes have been made
Cancel Exit
Save changes then exit this menu
Discard changes then exit this menu
Exit the Configuration Utility and Reboot

```

2. If you press **ESC** key on the “Adapter List” menu, a message prompts you whether or not to save the changes. Select the item you want and press **Enter** key when the message is displayed.

```

Are you sure you want to exit?
Cancel Exit
Save changes and reboot.
Discard changes and reboot.
Exit the Configuration Utility and Reboot

```

The changes made on SAS Configuration Utility will be effective after the reboot of the server.

Physical Formatting of the Hard Disk Drive

The following describes how to execute physical formatting of hard disk drive.

1. Press **Enter** key on the “Adapter List” menu.
“Adapter Properties” menu appears after a short while.

```

LSI Corp Config Utility      v6.28.00.00 (2009.02.03)
Adapter Properties -- SAS1068E

Adapter          C1068E
PCI Slot         00
PCI Address(Bus/Dev) 05:00
MPT Firmware Revision 1.28.00.00-IT
SAS Address      50030130:F1414300
NUDATA Version   2D.05
Status           Enabled
Boot Order       0
Boot Support     [Enabled BIOS & OS]

SAS Topology
Advanced Adapter Properties

Esc = Exit Menu      F1/Shift+1 = Help
Enter = Select Item  -/+ /Enter = Change Item
  
```

2. Select “SAS Topology” and press **Enter** key.
“SAS Topology” menu appears after a while.

```

LSI Corp Config Utility      v6.28.00.00 (2009.02.03)
SAS Topology -- SAS1068E

Device Identifier      Device
C1068E(05:00)          Info
  Enclosure            Direct Attach Devices_ Controller
  
```

3. Select the hard disk drive to execute physical formatting and press **Enter** key.
Hard disk drives that are installed on the primary CPU/IO module appear after a while.

```

LSI Corp Config Utility      v6.28.00.00 (2009.02.03)
SAS Topology -- SAS1068E

Device Identifier      Device
C1068E(05:00)          Info
  Enclosure            Direct Attach Devices_ Controller
    Bay 0              FUJITSU M4Y2073RC 2903 SAS
  
```

4. Select the hard disk drive to execute physical formatting and press **D** key while pressing **Alt** key. “Device Properties” menu appears after a while.

```
LSI Corp Config Utility      v6.28.00.00 (2009.02.03)
Device Properties -- SAS1068E

Device Identifier  FUJITSU MAY2073RC      2903
Scan Order        0
Slot Number       0
RAID Member       No
Device Information SAS
Disk Capacity (GB) 68
SAS Address       500000E0:167B0962
Serial Number     B389P77005LH

Format
Verify
```

Select “Format” and press **Enter** key.

“Device Format” menu appears after a while.

```
LSI Corp Config Utility      v6.28.00.00 (2009.02.03)
Device Format -- SAS1068E

Device Identifier  FUJITSU MAY2073RC      2903
SAS Address       500000E0:167B0962
Serial Number     B389P77005LH

WARNING! Format will change the sector size to 512 bytes.
Format will permanently erase all data on this device!
Format may take hours to complete and cannot be stopped.
Press the 'F' key to begin format or any other key to exit.
```

Press **F** key to start formatting.

After the completion of formatting, the following message appears.
Press any key to display “Device Properties” menu.

FORCED SHUTDOWN

Read this section if your server does not operate as expected.

Forced Shutdown

Use this function when an OS command does not shut down the server, the POWER switch does not turn off the server, or resetting does not work.

Press and hold the POWER switch on the server for over 4 seconds.

The power is forcibly turned off. To turn on the power back again, wait approximately 30 seconds after the forced shutdown.

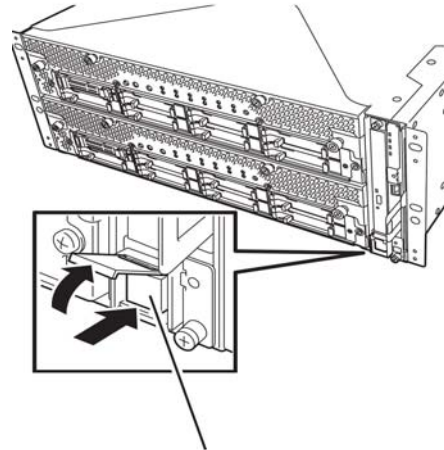

Press it for over 4 seconds.

REMOTE MANAGEMENT FUNCTION

R320a-E4 and R320a-M4 models are equipped with the internal Remote Management function. By connecting their management LAN port to network, you can remotely monitor and control the server such as keyboard, video and mouse (KVM) with BMC (Baseboard Management Controller), a system management LSI. As to the Remote Management Function and how to setup the function, refer to the [EXPRESSSCOPE Engine 2 User's guide [for ft series]] stored in the NEC EXPRESSBUILDER DVD.

Chapter 5

Installing and Using Utilities

This section describes how to use the NEC EXPRESSBUILDER DVD that comes with your server and to install the utilities stored on the NEC EXPRESSBUILDER. CPU/IO module has a processor function part and IO function part. In utilities in this chapter, the processor function part is referred to as CPU module and IO function part PCI module.

NEC EXPRESSBUILDER

The NEC EXPRESSBUILDER, integrated setup software, can automatically detect the hardware connected to an NEC Express5800/ft series machine to advance the processing. The hardware subject to setup with the NEC EXPRESSBUILDER should have the same configuration as that for operation.

Boot Selection Menu

When you insert the NEC EXPRESSBUILDER disk into the optical disk drive and reboot the system, the following menu appears.

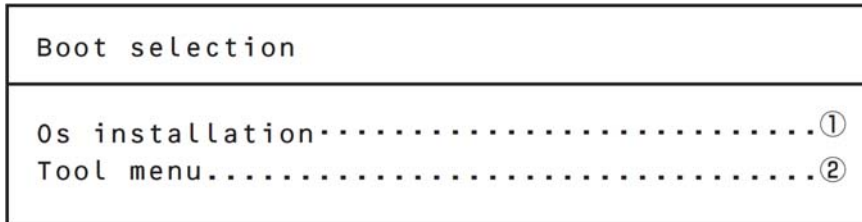

1. Os installation

If you select this item, the following confirmation screen appears.

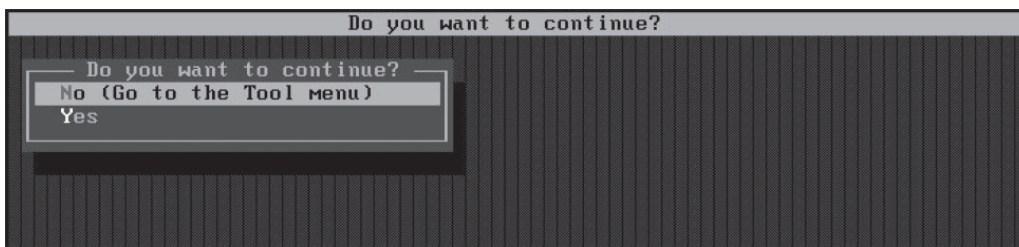

After selecting **Yes** on the confirmation screen, the Top menu appears.

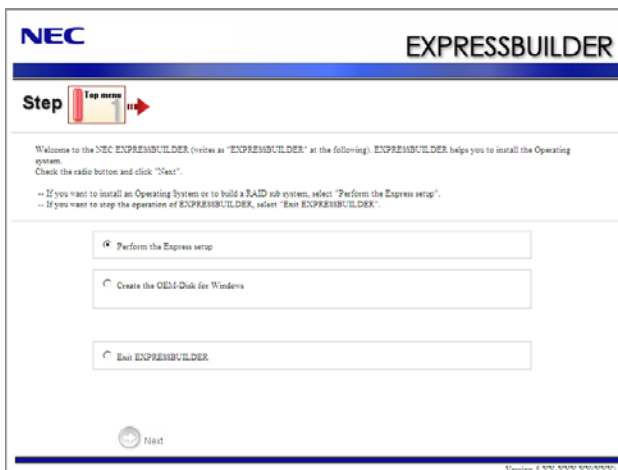

You can start up the OS install function, such as “ExpressSetup” from this menu. See User’s Guide (setup) for details.

2. Tool menu

If you select this item after choosing the display language, the Tool menu appears.

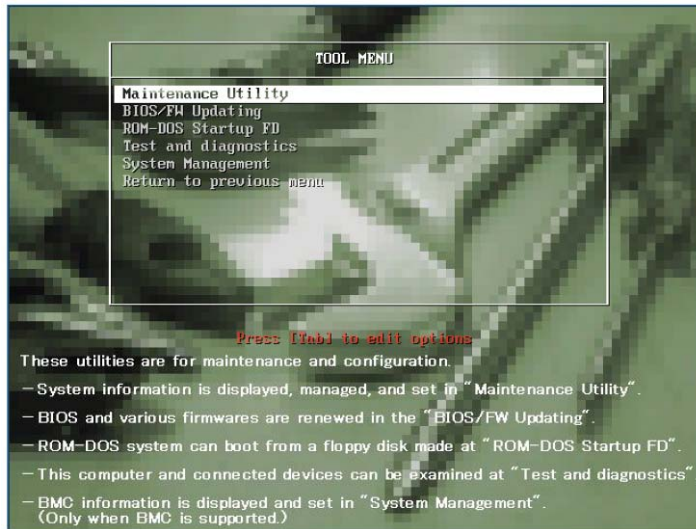

You can use the below functions for maintenance.

- Maintenance Utility
Starts up the Offline Maintenance Utility.
- BIOS/FW Updating
Updates the system BIOS.
- ROM-DOS Startup FD
Creates Startup FD is used for starting the ROM-DOS system.
- Test and Diagnostics
Starts up the system test and diagnostics.
- System Management
Starts up the system management function.

Autorun Menu

When the NEC EXPRESSBUILDER DVD is inserted into the optical disk drive, Windows automatically launches the menu as shown below.

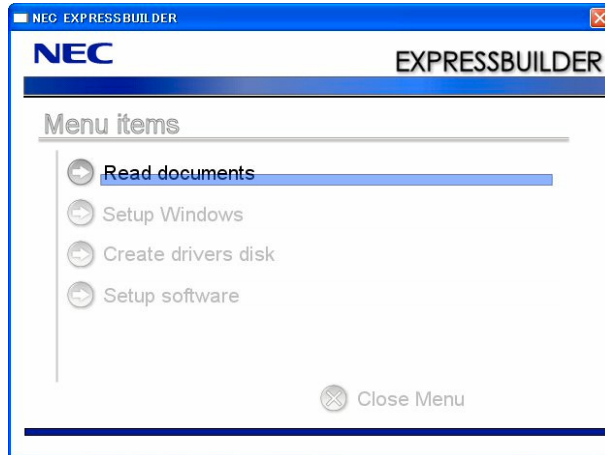

This menu is used to:

- Read the User's Guide or the other documents,
- Update the server system (Windows drivers), and
- Install the management software.

NOTES:

- This menu requires Microsoft Windows XP, Vista or Windows Server 2003 (or later).
 - This menu is not available for Microsoft Windows 2008 Server Core environment.
 - Some documents are provided in PDF format. Use Adobe Reader to view or print these documents.
-

If the menu does not appear, eject the DVD from the disk drive once and insert it again.

If you want to execute the menu again after the menu ended, select "My computer" by the Explorer, and double-click the icon of the disk drive that contains the NEC EXPRESSBUILDER DVD.

Some menu items are grayed-out when the logon user does not have the authority of the administrator or the menu item is not available for your system.

To use the menu,

- Click on the menu items, or
- Click the right mouse button on the menu window.

NEC ESMPRO Agent and Manager

NEC Express5800/ft series system management applications “NEC ESMPRO Manager” and “NEC ESMPRO Agent” are bundled to accessory “NEC EXPRESSBUILDER DVD.”

This section describes the functions and features provided by NEC ESMPRO Manager and NEC ESMPRO Agent and the notes on their operations.

These applications are necessary for continuous operation of NEC Express5800/ft series.

Overview

NEC ESMPRO Manager and NEC ESMPRO Agent are the server management software provided for the stable operation of a server system and effective system operations. They can manage the configuration information and operating status of server resources to prevent server faults from occurring. If a server fault occurs, they detect the fault to notify the system Administrator of the occurrence. This enables the system Administrator to take appropriate action against faults.

- Importance of server management

- “Constantly stable operation” and “less management workload” are keywords in server management.

- Stable operation of server

- Shutdown of a server immediately leads the customer to lose business opportunities and profits. This requires servers to always operate in their perfect state. If a fault occurs in a server, it is necessary to detect the occurrence as soon as possible, make clear the cause, and take appropriate action. The shorter the time taken from the occurrence of a fault to the recovery from the fault is, the smaller the loss of profits (and/or costs) is.

- Load reduction of server management

- The server management requires many jobs. In particular, if the system becomes large or remote servers are used, required jobs increase further. The reduction of the load of the server management brings the decrease in costs (and thus customer's benefit).

- What are NEC ESMPRO Manager and NEC ESMPRO Agent?

- NEC ESMPRO Manager and NEC ESMPRO Agent are server management software used to manage and monitor NEC Express5800 series systems on the network. The installation of NEC ESMPRO Manager and NEC ESMPRO Agent enables the server configuration, performance, and fault information to be acquired, managed, and monitored in real time and also the occurrence of a fault to be detected immediately by the alert report function.

- Effects of using NEC ESMPRO Manager and NEC ESMPRO Agent
 - NEC ESMPRO Manager and NEC ESMPRO Agent have sufficient effects on a variety of needs in versatile and complicated system environments.
 - Detection of server fault
 - NEC ESMPRO Agent collects a variety of fault information on NEC Express5800 series systems to identify the states of the systems. If a server detects a fault, the server provides NEC ESMPRO Manager with the proper alert report.
 - Prevention of server fault
 - NEC ESMPRO Agent includes the preventive maintenance function predicting the occurrence of a fault in advance as countermeasures for preventing faults from occurring. It can previously detect the increase in the chassis temperature and the empty capacity in a file system.
 - Management of server operation status
 - NEC ESMPRO Agent can acquire the detailed hardware configuration and performance information on NEC Express5800 series systems. The acquired information can be viewed at any point through NEC ESMPRO Manager.
 - Collective management of distributed servers
 - NEC ESMPRO Manager provides the GUI that allows servers distributed on the network to be managed efficiently.

Detection of Server Fault

NEC ESMPRO Manager and NEC ESMPRO Agent detect errors causing faults to occur at an early stage and notify Administrators of fault information real-time.

- Early detection of error

If a fault occurs, NEC ESMPRO Agent detects the fault and reports the occurrence of the fault to NEC ESMPRO Manager (alert report). NEC ESMPRO Manager displays the received alert in the AlertViewer and also changes the status colors of the server and server component in which the fault occurs. This allows you to identify the fault at a glance. Further, checking the content of the fault and the countermeasures, you can take appropriate action for the fault as soon as possible.

- Types of reported faults

The table below lists the typical faults reported by NEC ESMPRO Agent.

Component	Reported information
CPU	<ul style="list-style-type: none"> • CPU load is over the threshold • CPU degrading, etc.
Voltage	Voltage lowering
Temperature	Temperature increase in chassis, etc.
Fan	Fan failure (decrease in the number of revolutions), etc.
Storage	File system usage rate, etc.
LAN	<ul style="list-style-type: none"> • Line fault threshold over • Send retry or send abort threshold over, etc.

Prevention of Server Fault

NEC ESMPRO Agent includes the preventive maintenance function forecasting the occurrence of a fault as countermeasures for preventing faults from occurring.

NEC ESMPRO Manager and NEC ESMPRO Agent can set the threshold for the CPU usage rate and the empty capacity in a file system, etc. in the server. If the value of a source exceeds the threshold, NEC ESMPRO Agent reports the alert to NEC ESMPRO Manager.

The preventive maintenance function can be set for a variety of monitoring items including the CPU usage rate.

Management of Server Operation Status

NEC ESMPRO Agent manages and monitors a variety of components installed in the server. You can view the information managed and monitored by NEC ESMPRO Agent on the DataViewer of NEC ESMPRO Manager.

NEC ESMPRO Agent also manages and monitors components and conditions required to keep the server reliability at a high level such as hard disks, CPU, fans, power supply, and temperature.

Functional availability on the DataViewer

Function name	Availability	Function outline
Hardware	Available	This function shows the hardware's physical information.
Memory bank	Available	This function shows the memory's physical information.
Device information	Available	This function shows the device's unique information.
CPU	Available	This function shows CPU's physical information.
System	Available	This function shows CPU's logical information and monitors CPU utilization. This function shows memory's logical information and monitors the status.
I/O devices	Available	This function shows information about I/O devices (such as Floppy disk, serial port, parallel port, keyboard, mouse, video). * A mouse is undisplayed on DataViewer of the NEC ESMPRO Manager, as there is no /etc/sysconfig/mouse file for NEC ESMPRO Agent to refer to on the Red Hat Enterprise Linux 5. * For Vertical, Horizontal and Pixel on the DataViewer, 0 is displayed when the user does not locally login (on the user name entering screen).
System environment	Available	This function monitors temperature, fan, voltage, power supply and door. * Monitor is always effective. It cannot change it for invalidity.
Temperature	Available	This function monitors temperature inside of chassis.
Fan	Available	This function monitors fan.
Voltage	Available	This function monitors voltage inside of chassis.
Power supply	Unavailable	This function monitors power supply unit.
Door	Unavailable	This function monitors chassis intrusion(open/close of cover/door of chassis).
Software	Available	This function shows information about service, driver and OS.
Network	Available	This function shows network (LAN) information and monitors packet. * After NEC ESMPRO Agent Ver4.3, the default of the monitor setting of the network (LAN) monitor disable.
Expansion device	Unavailable	This function shows information about expansion bus device.
BIOS	Available	This function shows BIOS information.
Local polling	Available	This function monitors values of MIB that agent takes at random.
Storage	Unavailable	This function monitors controllers and storage devices such as HDD.
File system	Available	This function shows file system structure and monitors utilization.
Disk array	Unavailable	This function monitors LSD disk array controller (N8103-73A/80/81) and Promise disk array controller.
Others	Unavailable	This function monitors OS stall by using Watch Dog Timer.

Monitoring (Management) of NEC Express5800/ft series

NEC Express5800/ft series is a fault tolerant system. It can continue the operation even if a major component fails. NEC Express5800/ft series improves the system availability with the hardware, NEC ESMPRO, and system software functions.

If a major component fails, the NEC ESMPRO fault report function can notify the system Administrator of the occurrence of the fault. In addition, the DataViewer of NEC ESMPRO Manager can monitor the system status and also identify the failed component.

NEC ESMPRO provides several maintenance functions such as the update of F/W and BIOS in the NEC Express5800/ft series in the online state (in which the system continues the operation but the components used to update F/W or BIOS is suspended) and the suspension of a specific component.

The table below lists the NEC Express5800/ft series management tasks using NEC ESMPRO and system functions.

NEC Express5800/ft series management task	NEC ESMPRO function or tool (on managed NEC Express5800/ft series)*	NEC ESMPRO function or tool (on management manager)
Monitoring of major component states	–	NEC ESMPRO Manager DataViewer
Diagnosis and start/stop of major components and F/W update	NEC ESMPRO Agent ft server utility	NEC ESMPRO Manager DataViewer
Verification of alert or verification of fault occurrence event information	syslog (/var/log/messages)	NEC ESMPRO Manager AlertViewer

* When the administration manager is also the managed NEC Express5800/ft series (or NEC ESMPRO Manager is installed on the managed NEC Express5800/ft series), all functions of the administration manager can be used on the managed NEC Express5800/ft series.

The report of a fault occurrence in the NEC Express5800/ft series (alert) is immediately sent to the NEC ESMPRO Manager. When the NEC ESMPRO Manager receives the alert, a popup message appears.

The alert contains the detailed information of the fault and the proper countermeasures. You can take the appropriate action for the alert.

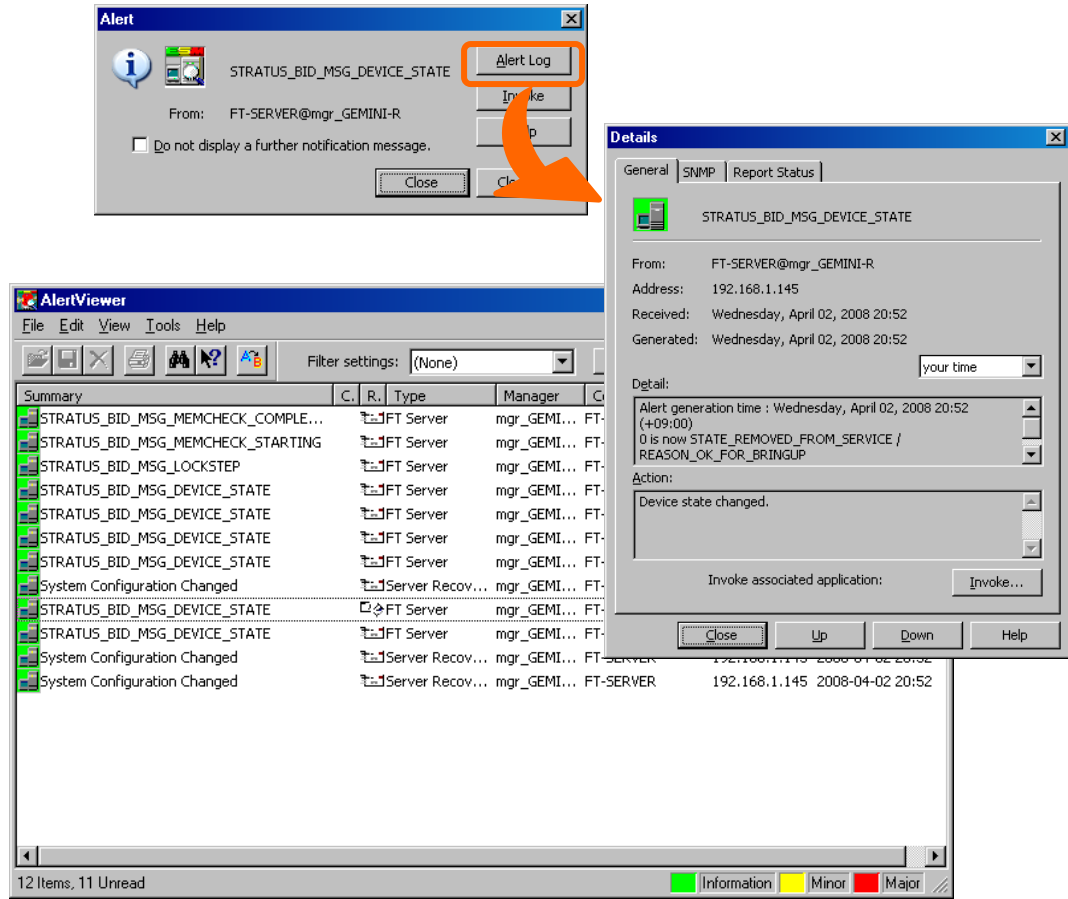

Collective Management of Distributed Servers

The excellent GUI provided by NEC ESMPRO Manager allows servers on a network to be managed collectively. The management screen is designed in the Explorer format to indicate the components in a server hierarchically for effective server management.

NEC ESMPRO Manager manages servers by using the following three types of GUIs.

- Operation Window

The operation window is used to create the map of servers connected to network to manage them. The map can be multi-layered depending on the installation areas, organizations, and objects.

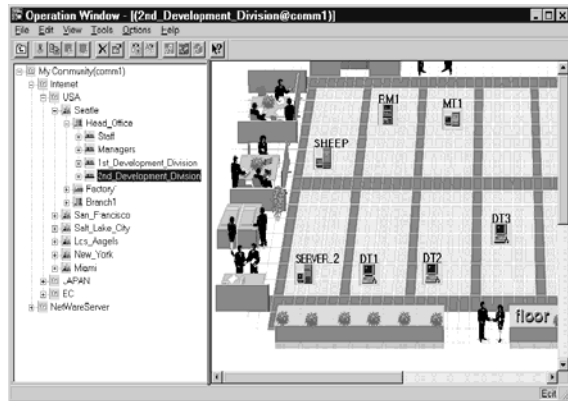

NEC ESMPRO Agent

NEC ESMPRO Agent is a utility which acts as an agent (proxy) between NEC Express5800/ft series and NEC ESMPRO Manager (management PC). For details on the operating environment, the setting required before the setup, and the installation procedure, see the separate volume “User’s Guide (Setup).”

Device ID in Alert Report

Some NEC Express5800/ft series reports use unique device IDs which correspond to the devices listed in the table below as the device identification information.

Device name	Device ID
CPU module 0	0
DIMM slot 1 on CPU module 0	0/1
DIMM slot 2 on CPU module 0	0/2
DIMM slot 3 on CPU module 0	0/3
DIMM slot 4 on CPU module 0	0/4
DIMM slot 5 on CPU module 0	0/5
DIMM slot 6 on CPU module 0	0/6
DIMM slot 7 on CPU module 0	0/7
DIMM slot 8 on CPU module 0	0/8
DIMM slot 9 on CPU module 0	0/9
DIMM slot 10 on CPU module 0	0/10
DIMM slot 11 on CPU module 0	0/11
DIMM slot 12 on CPU module 0	0/12
CPU1 on CPU module 0	0/21
CPU2 on CPU module 0	0/22
CPU module 1	1
DIMM slot 1 on CPU module 1	1/1
DIMM slot 2 on CPU module 1	1/2
DIMM slot 3 on CPU module 1	1/3
DIMM slot 4 on CPU module 1	1/4
DIMM slot 5 on CPU module 1	1/5
DIMM slot 6 on CPU module 1	1/6
DIMM slot 7 on CPU module 1	1/7
DIMM slot 8 on CPU module 1	1/8
DIMM slot 9 on CPU module 1	1/9
DIMM slot 10 on CPU module 1	1/10
DIMM slot 11 on CPU module 1	1/11
DIMM slot 12 on CPU module 1	1/12
CPU1 on CPU module 1	1/21
CPU2 on CPU module 1	1/22
PCI module 0	10
PCI slot 1 on PCI module 0	10/1
PCI slot 2 on PCI module 0	10/2
PCI slot 3 on PCI module 0	10/3
PCI slot 4 on PCI module 0	10/4
Mass storage controller on PCI module 0	10/5
Network controller on PCI module 0	10/6

Device name	Device ID
Display controller on PCI module 0	10/7
Serial bus controller on PCI module 0	10/8
Serial bus controller on PCI module 0	10/9
Bridge	10/10
PCI module 1	11
PCI slot 1 on PCI module 1	11/1
PCI slot 2 on PCI module 1	11/2
PCI slot 3 on PCI module 1	11/3
PCI slot 4 on PCI module 1	11/4
Mass storage controller on PCI module 1	11/5
Network controller on PCI module 1	11/6
Display controller on PCI module 1	11/7
Serial bus controller on PCI module 1	11/8
Serial bus controller on PCI module 1	11/9
Bridge	11/10
SCSI enclosure 0	10/40
SCSI slot 0 on SCSI enclosure 0	10/40/1
SCSI slot 1 on SCSI enclosure 0	10/40/2
SCSI slot 2 on SCSI enclosure 0	10/40/3
SCSI slot 3 on SCSI enclosure 0	10/40/4
SCSI slot 4 on SCSI enclosure 0	10/40/5
SCSI slot 5 on SCSI enclosure 0	10/40/6
SCSI slot 6 on SCSI enclosure 0	10/40/7
SCSI slot 7 on SCSI enclosure 0	10/40/8
SCSI enclosure 1	11/40
SCSI slot 0 on SCSI enclosure 1	11/40/1
SCSI slot 1 on SCSI enclosure 1	11/40/2
SCSI slot 2 on SCSI enclosure 1	11/40/3
SCSI slot 3 on SCSI enclosure 1	11/40/4
SCSI slot 4 on SCSI enclosure 1	11/40/5
SCSI slot 5 on SCSI enclosure 1	11/40/6
SCSI slot 6 on SCSI enclosure 1	11/40/7
SCSI slot 7 on SCSI enclosure 1	11/40/8

* “SCSI” includes SAS.

Supplement

Note the followings when using NEC ESMPRO Agent.

Notice on running NEC ESMPRO Agent

NEC ESMPRO Agent sometimes cannot send alert report after recovering from hardware failure.

[Workaround]

Execute the following procedure after recovering from hardware failure.

After replacing the hardware, confirm both of the CPU/IO module status lamp 2s turn green (duplex), login as a root user, and then run the following command.

```
# /opt/nec/esmpro_sa/bin/ESMRestart
```

For status lamp positions, refer to “Names and Functions of Components” in Chapter 2 “General Description” in User’s Guide.

Displaying ft Server utility

When you start ft server utility starts by using GNOME terminals from X Windows or console command, the right part of the initial screen goes beyond the screen by defaults. There is no problem on using the utility as it is. The screen refreshes and back to normal when you press [Ctrl]+[L].

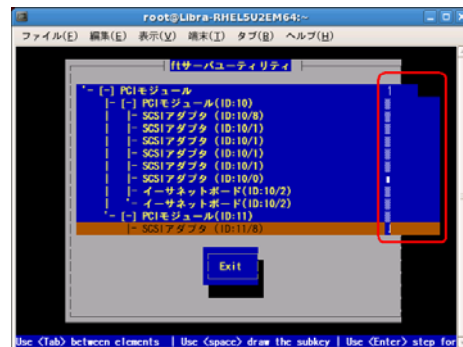

Portmap

ESMPRO/ServerAgent uses the function of portmap.

If portmap stops or reactivates while operating ESMPRO/ServerAgent, ESMPRO/ServerAgent cannot be normally operated. Please execute the following commands, and reactivate ESMPRO/ServerAgent.

```
# /opt/nec/esmpro_sa/bin/ESMRestart.
```

Maintenance-related Functions

When you want to use maintenance-related functions of the NEC Express5800/ft series, contact your maintenance personnel.

CPU Information

If you select [CPU Module] – [CPU] in the [ft] tree of the DataViewer, unknown or incorrect information appears in some information items.

The CPU information can be viewed by selecting [System] – [CPU] in the [ESMPRO] tree.

Change of Installation States of CPU and PCI Modules

If you dynamically change the configuration of the CPU or PCI module in the relevant system during review of the server information by using the DataViewer, the information in the DataViewer may be different from the current system information because the change of the system configuration is not reflected on the DataViewer. Please execute the following commands, and reactivate ESMPRO/ServerAgent.

```
# /opt/nec/esmpro_sa/bin/ESMRestart
```

In addition, please restart ft server utility when it started ft server utility.

Impact When Module Status Changes

PCI modules, SCSI adapters, SCSI buses, and modules under the SCSI enclosure have impact on each other. For example, when the “Status” item of a module changes to “fault,” it may be caused by another module’s error. Therefore, you need to check the status of the other modules based on alert information.

LAN Monitoring Report

The LAN monitoring function defines the line status depending on the number of transmission packets and the number of packet errors within a certain period. Thus, the LAN monitoring function may report a line fault or high line load only in a temporary high line impedance state. If a normal state recovery is reported immediately, temporal high line impedance may have occurred thus there is not any problem.

Setting of Data viewer at update intervals

Set the update interval of Data Viewer 60 seconds(default) or more.
Otherwise, a report might be delayed or not be sent.

Set Memory usage of ntagent

The memory usage of ntagent will increase by about 10KB in an hour when the DataViewer is displayed. Please do not display the Dataviewer, and display it only when you occur the trouble.

LAN Monitoring Threshold

Because a hardware trouble on the network is detected at driver level, NEC ESMPRO Agent does not monitor line faults. Thus, the value set for “Line fault occurrence rate” of a [LAN] tab of [NEC ESMPRO Agent properties] in the control panel is not used.

Change of SNMP Community

If the security setting of the SNMP Service of a system, where the NEC ESMPRO Agent is installed, is changed from the default “public” to a community name, change the community settings of the NEC ESMPRO Agent, too.

1. Login as a root user.
2. Go to the folder where NEC ESMPRO Agent control panel is installed.
`# cd /opt/nec/esmpro_sa/bin`
3. Start the control panel.
`# ./ESMagentconf`
The control panel is displayed.
4. Select [General].
The [General property] is displayed.
5. Select a desired community name from the [SNMP Community] list box in [SNMP Setting] of the [General] sheet.
6. Click [OK] to terminate the operation.

Connection with Hard Disk Drive

The preventive hard disk drive maintenance function may not work properly when a hard disk drive which was used in a system where NEC ESMPRO Agent is installed is connected to other systems. Make sure not to connect such hard disk drives.

Change Settings of File System Monitoring Function

New settings in thresholds of monitoring interval and free space monitoring are not reflected immediately after they are changed. They are reflected at the next monitoring interval of monitoring service.

CPU Load Ratio of SNMP Service

While monitoring the server from NEC ESMPRO Manager, the CPU load ratio of SNMP Service on the NEC ESMPRO Agent side may increase at every monitoring interval (default: 1 minute).

NEC ESMPRO Manager and NEC ESMPRO Agent exchange information through SNMP Service. If the server status monitoring by NEC ESMPRO Manager is on (default: ON), NEC ESMPRO Manager regularly issues a request to NEC ESMPRO Agent to get the current status of the server. In response, NEC ESMPRO Agent checks the status of the server. As a result, the CPU load ratio of SNMP Service increases temporarily.

If you have trouble of terminating a movie player application, turn off the server status monitoring by NEC ESMPRO Manager or extend the monitoring interval.

Hang of SNMP Service

SNMP Service has a module called "SNMP Extended Agent." This module may be registered when you install some software that uses SNMP Service.

If you start SNMP Service, SNMP Extended Agent is also loaded at the initialization. However, if the initialization is not completed within a specified period, SNMP Service will hang.

It may take time to complete the initialization due to temporary high load on the system. In this case, wait for the system load become low enough before restarting SNMP Service.

When [ft] Tree Appears on Date Viewer in an Incorrect Manner

If you open a DataViewer immediately after the system starts up, the tree or the state of a DataViewer may not be displayed correctly due to high load of the system. Please restart a DataView again in about 5 minutes.

When [ft] Tree Appears on Date Viewer in the Ethernet Board

When it chose the [Ethernet Board] of the [ft] tree, some information is displayed with "unknown" or "0:0:0:0:0:0".

About the state of the network, please use a vndctl command (NIC setting tool).

```
# vndctl status
```

About the packet information, please refer to [Network Information] of the [ESMPRO] tree.

Ethernet Adapters You Do Not Use

When the cables are not connected to the Ethernet adapter ports, NEC ESMPRO Agent determines that the ports are faulty (does not have any media), and the status color of [ft] – [PCI module] – [Ethernet Board] of the Data Viewer turns red (abnormal). The server status color of Operation Window also turns red (abnormal).

As to the ports of the unused Ethernet adapter, connect the unused port of PCI module 0 and that of PCI module 1 with a cross cable.

DataViewer display when only one of the PCI modules (IO modules) is operating

When only one of the PCI modules (IO modules) is operating (non-dual configuration), the SCSI enclosure or mirror disk status cannot be displayed normally.

To check if the dual configuration is changed to the simplex operation mode, check the event log, AlertViewer log, or the status color of PCI module of DataViewer.

Display of Ethernet Board of ftServer Utility

FtServer Utility displays the information of Network Controller. Express5800/320Fd-LR/MR has four in-built Network Ports. Two trees of the Ethernet Board are displayed since a module has two Network Controllers.

Chipset Information

"Unknown" is displayed as the type of the chipset information in the [ft]-[CPU Module]-[General] view of the DataViewer (It is blank in the Web Component).

DIMM Information

"Unknown" is displayed as the memory type in the [ft]-[CPU Module]-[DIMM] view of the DataViewer (It is blank in the Web Component).

NEC ESMPRO Manager

To monitor and manage a computer, on which NEC ESMPRO Agent is installed, with a management PC online, use NEC ESMPRO Manager that is bundled with the product.

For detailed procedures of installation and setting, see online documents or NEC ESMPRO Online Help.

TIPS:

- Online documents provide cautions and information for using NEC ESMPRO Manager. See *NEC ESMPRO Manager User's Guide* in the NEC EXPRESSBUILDER DVD.
 - The sample screen shown in this subsection may differ from that of your server software; however, it offers the same function.
-

Monitoring by Use of DataViewer

To monitor the state of the NEC Express5800/ft series on a management computer with installation of NEC ESMPRO Manager, the DataViewer is used. If you click each of the modules and items to be checked sequentially on the tree view in the Windows Explorer format, the DataViewer indicates their states on the right side of the screen.

You can manage the status on a Web browser using Web component functions of NEC ESMPRO Manager. For details, see Help on Web Component.

This section describes the tree structure and displayed screens in the DataViewer.

To make the DataViewer indicate the state of each module and those of the components on it, select the server to be monitored from NEC ESMPRO Manager to start the DataViewer (in the following description, the start procedure of the DataViewer is omitted).

Monitoring CPU Module

To monitor the CPU modules and the components on the CPU module, see the [CPU Module] tree. To see the information on the [CPU Module] tree, select the target CPU module from [CPU Module] in the [ft] tree.

You can see the following information on the modules and the components on the CPU modules in the [CPU Module] tree.

- General

Allows the configuration and other information on the CPU modules to be viewed.

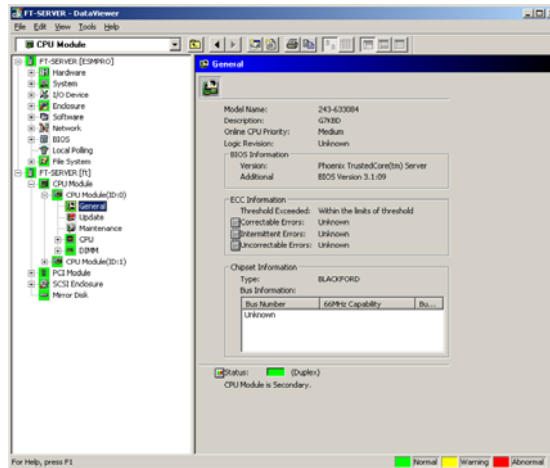

- Maintenance

Allows the start/stop, MTBF information clear, dump acquisition, and diagnosis of the CPU modules to be provided. See “Maintenance of NEC Express5800/ft series” described later for the start/stop and MTBF information clear of the CPU modules.

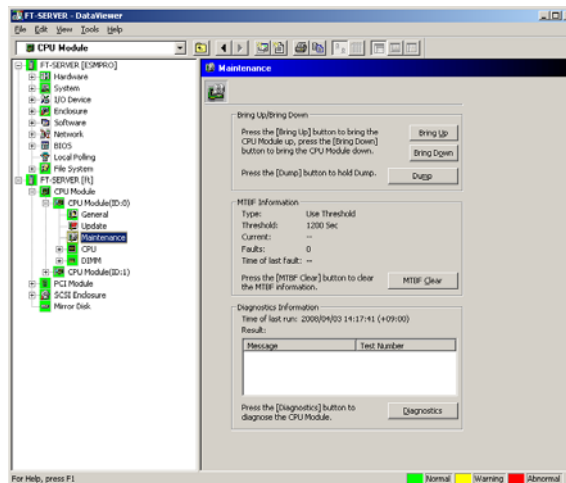

■ Update

Allows the device identification information of the CPU modules to be viewed and BIOS of the CPU modules to be updated. See “Maintenance of NEC Express5800/ft series” described later for the update of BIOS of the CPU modules. The detailed device identification information can be checked by selecting [ESMPRO] tree→[Hardware] →[Field Replaceable Unit].

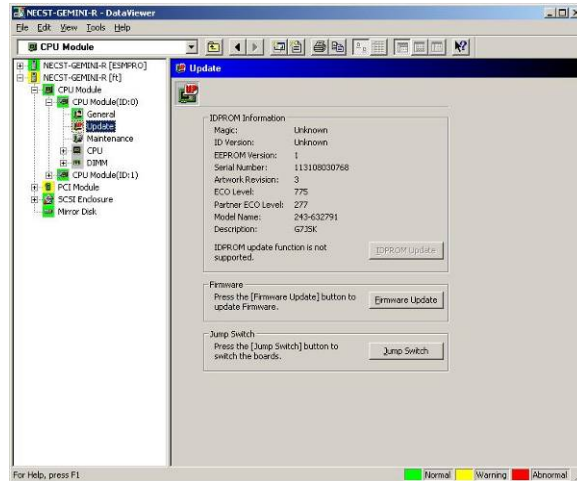

■ CPU

Allows the information of the CPU on the CPU modules to be viewed.

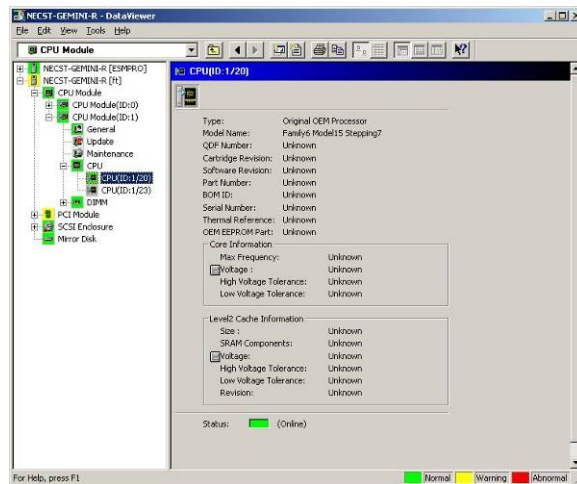

■ DIMM

Allows the information of DIMM on the CPU modules to be viewed.

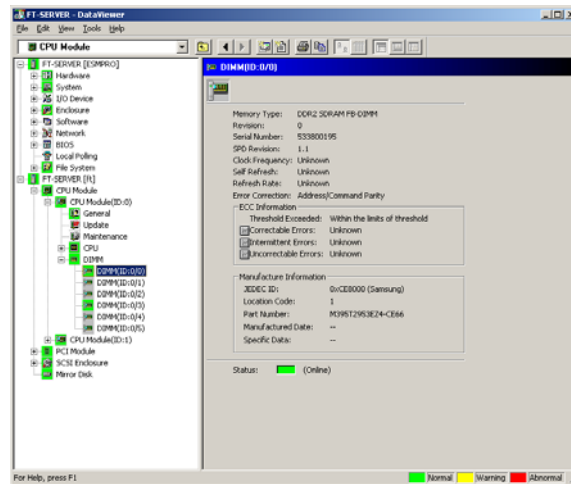

Monitoring PCI Module

To monitor the PCI modules and the components on the PCI modules, refer to the [PCI Module] tree. To see the information on the [PCI Module] tree, select the target PCI module from [PCI Module] in the [ft] tree.

You can see the following information on the PCI modules and the components on the PCI modules of the [PCI Module] tree.

(This section describes the general information screens of the PCI modules. The components on the PCI modules are described later.)

- General

Allows the configuration and other information of the PCI modules to be viewed.

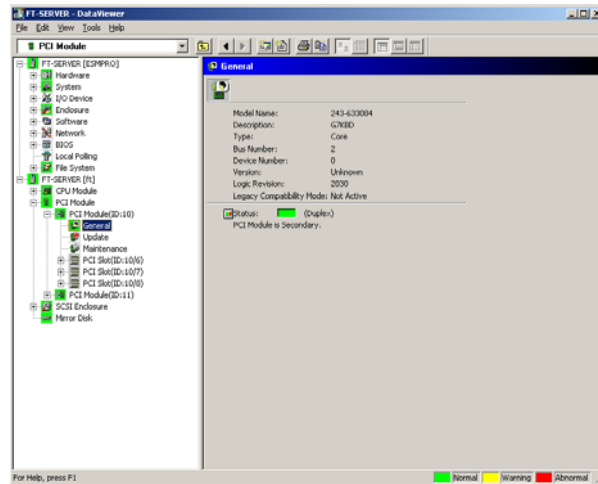

■ Maintenance

Allows the start/stop, MTBF information clear, and diagnosis of the PCI modules to be provided. See “Maintenance of NEC Express5800/ft series” described later for the start/stop and MTBF information clear of the CPU modules.

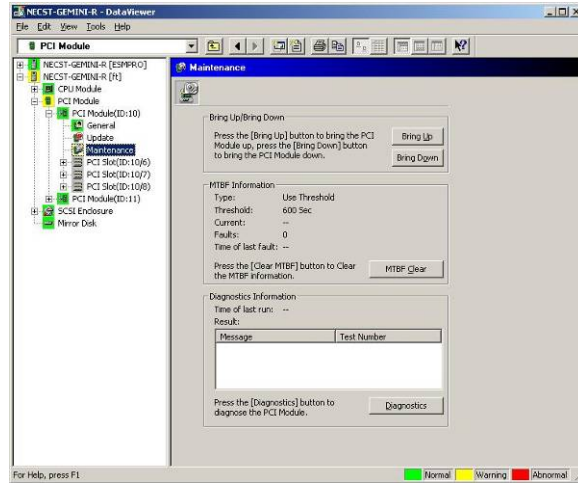

■ Update

Allows the device identification information of the PCI modules to be viewed. The detailed device identification information can be checked by selecting [ESMPRO] tree→[Hardware] tree→[Field Replaceable Unit] tree.

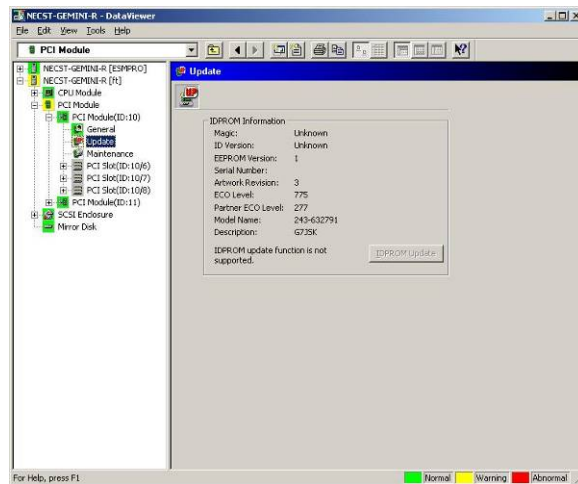

Monitoring PCI Slots and Devices on PCI Module

To monitor the PCI slots and devices on the PCI modules, see the [PCI slot] tree. To see the information on the [PCI slot] tree, select [PCI Module]→[PCI module (containing PCI slot to be seen)]→[PCI slot] of the [ft] tree.

You can see the following information on the PCI slot and the devices on the PCI slot in the [PCI slot] tree.

- General

Allows the PCI slot configuration information to be viewed.

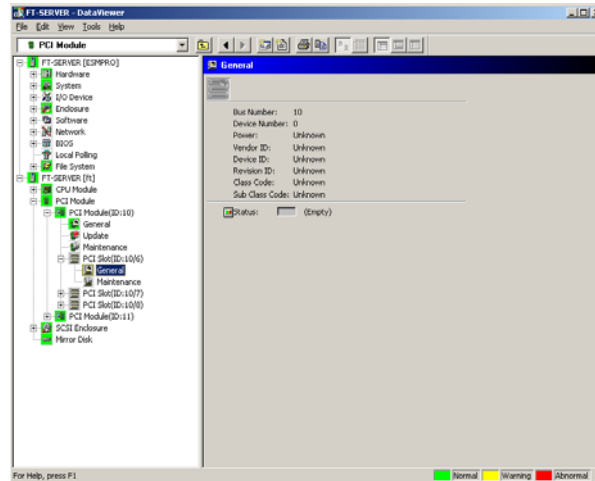

- Maintenance

Allows a device on the PCI slot to be started. This function is not supported in the current version.

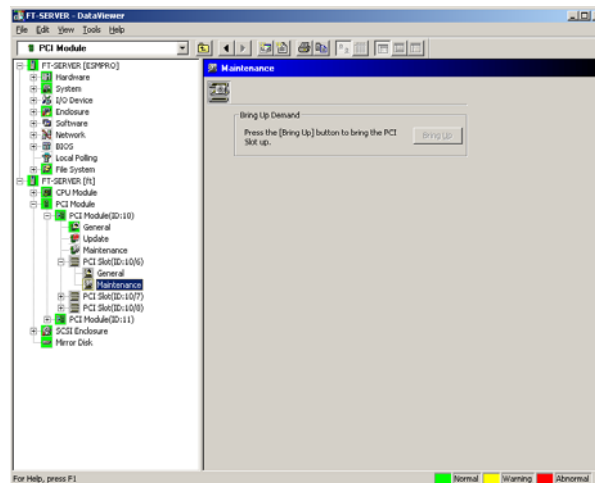

- **PCI Device – General**
Allows the information of devices on the PCI slot to be viewed.
This function is not supported in the current version.
- **PCI Device – Detail**
Allows the detailed information of a device on the PCI slot to be viewed.
This function is not supported in the current version.
- **PCI Bridge – General**
Allows the information of bridges on the PCI bus to be viewed.
This function is not supported in the current version.
- **PCI Bridge – Bus**
Allows the bus information of a bridge on the PCI bus to be viewed.
This function is not supported in the current version.
- **PCI Bridge – Detail**
Allows the detailed information of a bridge on the PCI bus to be viewed.
This function is not supported in the current version.

Monitoring SCSI adapter on PCI module

To monitor the SCSI adapters on the PCI modules, see the [SCSI adapter] tree. To see the information on the [SCSI adapter] tree, select [PCI Module]→[PCI module (connected to SCSI adapter to be seen)]→[SCSI adapter] of the [ft] tree.

You can see the following information on the SCSI adapters in the [SCSI adapter] tree.

- General
This allows the SCSI configuration information to be viewed.
- Maintenance
This allows the MTBF information of SCSI adapters to be viewed and cleared.
- Update
This function is not supported in the current version.
- SCSI bus
This function is not supported in the current version.

Monitoring Ethernet adapter on PCI module

To monitor the Ethernet adapters on the PCI modules, see the [Ethernet Board] tree.

To see the information on the [Ethernet Board] tree, select [PCI Module] [PCI module (connected to the Ethernet adapter to be seen)] [Ethernet Board] of the [ft] tree.

You can see the following information on the Ethernet adapters in the [Ethernet Board] tree.

IMPORTANT:

When there is unused Ethernet adapter, ESMPRO Agent determines that the port is faulty (does not have any media), and the status color of [ft] - [PCI module] - [Ethernet Board] of the DataViewer turns red (abnormal). The server status color of the integrated viewer also turns red (abnormal).

You need to connect the PCI module 0 and the PCI module 1 with the cross LAN cable when these Ethernet ports are not in use.

- General

This allows the ethernet configuration information to be viewed.

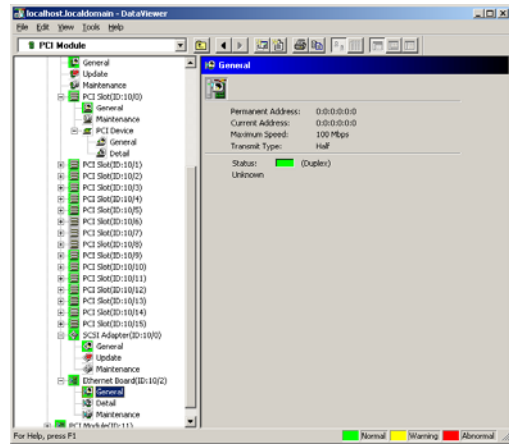

- Detail

This allows the communication data of the ethernet adaptor to be viewed.

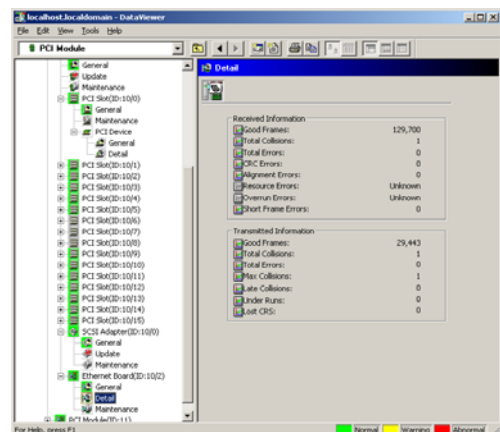

- Maintenance

This allows to refer/clear the MTBF information of the ethernet adaptor. See “Maintenance of NEC Express5800/ft series” described later for the MTBF information clear of the ethernet adapter.

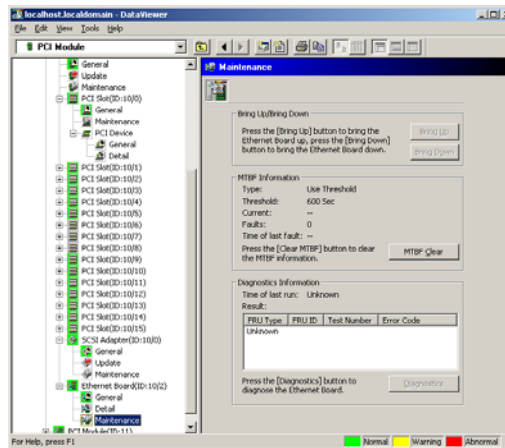

Monitoring SCSI Enclosure

To monitor the SCSI enclosure, see the [SCSI enclosure] tree. To see the information on the [SCSI enclosure] tree, select [SCSI enclosure] of the [ft] tree.

You can see the following information of the SCSI enclosure from the [SCSI enclosure] tree.

- General
This function is not supported in the current version.
- Maintenance
This function is not supported in the current version.
- Update
This function is not supported in the current version.
- Electronics – General
This function is not supported in the current version.
- Electronics – Maintenance
This function is not supported in the current version.
- SCSI Slot – General
This function is not supported in the current version.
- SCSI Slot – Maintenance
This function is not supported in the current version.

Monitoring Mirror Disk

To monitor the mirror disk components, see the [Mirror Disk] tree. To view information on [Mirror Disk] tree, select [Mirror Disk] under [ft] tree.

You can see the redundancy status of the mirrors and the device IDs of the SCSI slots into which these hard disk components are connected.

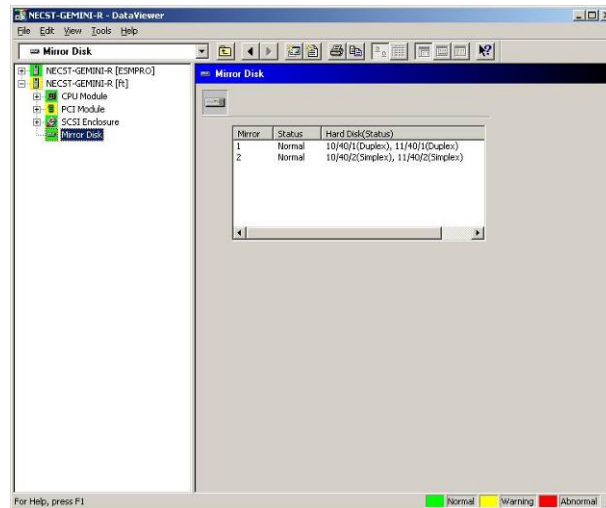

[Mirror Disk]

Maintenance of NEC Express5800/ft series

NEC Express5800/ft series maintenance can be done in two ways; one is to use NEC ESMPRO Manager for remote maintenance and the other is to use the NEC ESMPRO Agent ft server utility on the NEC Express5800/ft series for local maintenance.

TIPS: To start the NEC ESMPRO Agent ft server utility installed in the NEC Express5800/ft series, select the items as follows:

```
# /opt/nec/esmpro_sa/bin/ESMftcutil
```

The maintenance functions that can be executed from NEC ESMPRO include three types, those common to all components, those specific to particular components, and general system settings.

The maintenance functions common to all components are operated in the same way basically (the operation procedure and typical examples of screen images are described below).

The table below lists the availability of maintenance functions common to all components.

Component	Start		Stop		MTBF clear		Diag-nosis		F/W update	
	R	L	R	L	R	L	R	L	R	L
CPU module	√	√	√	√	√	√	-	-	√	√
PCI module	√	√	√	√	√	√	-	-	-	-
PCI slot	-	-	-	-	-	-	-	-	-	-
Ethernet adapter	-	-	-	-	-	-	-	-	-	-
SCSI adapter	-	-	-	-	-	-	-	-	-	-
SCSI enclosure	-	-	-	-	-	-	-	-	-	-
SCSI electronics	-	-	-	-	-	-	-	-	-	-
SCSI slot	-	-	-	-	-	-	-	-	-	-

R: Remote. Executable from remote management PC by using NEC ESMPRO Manager

L: Local. Executable on local server by using ft server utility

√: Supported

-: Not supported

Note: The MTBF clear of SCSI adapter and Ethernet cannot be performed to built-in devices.

The table below shows the component-specific maintenance functions executable from NEC ESMPRO.

Component	Dump harvest		Dump harvest during system operation		Board switch	
	R	L	R	L	R	L
CPU module	–	–	–	–	–	–

R: Remote. Executable from remote management PC by using NEC ESMPRO Manager

L: Local. Executable on local server by using ft server utility

√: Supported

–: Not supported

Component	Bus reset		Change of primary SCSI bus	
	R	L	R	L
SCSI bus	–	–	–	–

R: Remote. Executable from remote management PC by using NEC ESMPRO Manager

L: Local. Executable on local server by using ft server utility

√: Supported

–: Not supported

The table below shows the support of the whole system setup functions.

Component	Quick dump		Auto firmware update		Auto module start	
	R	L	R	L	R	L
Whole system	–	–	–	–	–	–

R: Remote. Executable from remote management PC by using NEC ESMPRO Manager

L: Local. Executable on local server by using ft server utility

√: Supported

–: Not supported

The table below shows the support of the preventive disk maintenance (S.M.A.R.T.) setup function.

Component	Preventive disk maintenance (S.M.A.R.T.) setup	
	R	L
SCSI disk	–	–

R: Remote. Executable from remote management PC by using NEC ESMPRO Manager

L: Local. Executable on local server by using ft server utility

√: Supported

–: Not supported

Start and Stop of Components

To start or stop a component with NEC ESMPRO Manager, use the [Maintenance] tree of the component in the [ft] tree of the DataViewer. Open the tree of the component to be started or stopped and select the [Maintenance] tree.

To start or stop a component with the ft server utility, use the utility screen of the component.

The table below shows the common cases in which a component is to be started or stopped.

Component	Start		Stop	
	Remote	Local	Remote	Local
CPU Module	<p>When the cause of down is reviewed and the system is restarted in module down state.</p> <p>Executable in any of the following module states (this can be viewed on manager screen):</p> <ul style="list-style-type: none"> • Removed • Broken • Shot • Firmware Update Complete • Diagnostics Passed 	<p>When the cause of down is reviewed and the system is restarted in module down state.</p> <p>Executable in the following module state:</p> <ul style="list-style-type: none"> • When the status LED 1 is amber and the status LED 2 is off <p>Only the status LED illuminates amber when the module is in one of the following states:</p> <ul style="list-style-type: none"> • Removed • Broken • Shot • Firmware Update Complete • Diagnostics Passed 	<p>When system is stopped forcibly due to replacement or malfunction of module.</p> <p>Executable in the following module state (this can be viewed on manager screen):</p> <ul style="list-style-type: none"> • Duplex 	<p>When system is stopped forcibly due to replacement or malfunction of module.</p> <p>Executable in the following module state:</p> <ul style="list-style-type: none"> • Only the green LED is on and in redundant configuration state <p>The both green LEDs are on when the module is in the following state:</p> <ul style="list-style-type: none"> • Duplex
PCI Module	Same as above	Same as above	Same as above	Same as above

Remote: Executable from remote management PC by using NEC ESMPRO Manager

Local: Executable on local server by using ft server utility

–: Not supported

IMPORTANT: PCI modules, SCSI adapters, SCSI buses, and modules under the SCSI enclosure have impact on each other. You need to be aware of this, for example, when you replace a PCI module. For details, see “Impact When Module Status Changes” described earlier in this chapter.

Procedure in NEC ESMPRO Manager

Start

1. Select the target component in the [ft] tree.
2. Check the current state with the “Status” display on the target component screen.
3. Click the [Bring Up] button in the [Maintenance] screen for the target component.

A certain time is required for the start.

The start result can be verified by “State” on the target component screen. The result of the start operation is reported by the NEC Express5800/ft series as an alert.

Stop

Perform the procedure below before replacing a component.

1. Select the target component in the [ft] tree.
2. Check the current state with the “State” display on the target component screen.
3. Click the [Bring Down] button in the [Maintenance] screen for the target component.

A certain time is required for the stop.

The stop result can be verified by “State” on the target component screen. The result of the stop operation is reported by the NEC Express5800/ft series as an alert.

Sample screen of NEC ESMPRO Manager 1

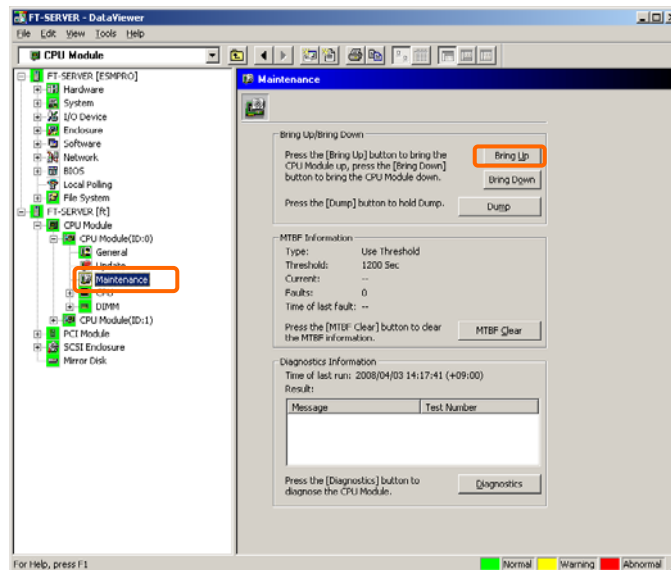

[Maintenance] screen of PCI module
[CPU Module] – [CPU Module] - [Maintenance]

Sample screen of NEC ESM PRO Manager 2

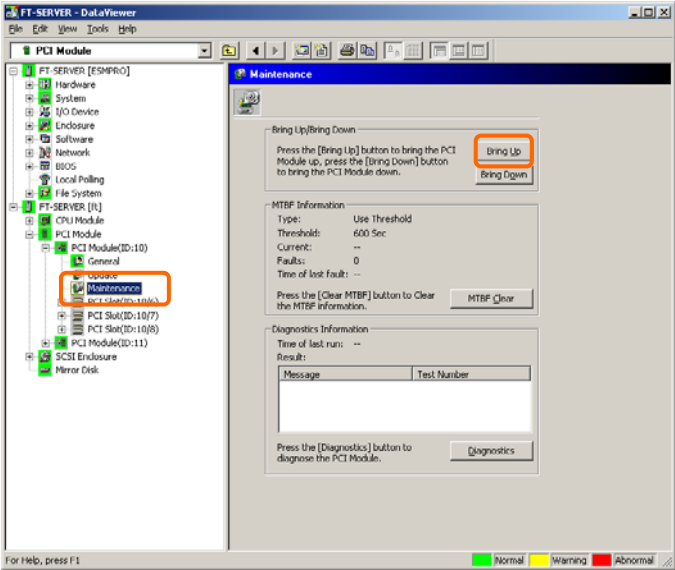

[Maintenance] screen of PCI module
[PCI Module] - [Maintenance]

Procedure in the ft server utility

Start

1. Select the target component by using the ft server utility.
2. Check the current state of the target component with the LEDs.
3. Click the [Start] button of the target component.

A certain time is required for the start.

The start result can be verified by the LEDs on the target component. The result of the start operation is registered in the event log.

Stop

1. Stop before replacing components.
2. Select the target component by using the ft server utility.
3. Check the current state of the target component with the LEDs.
4. Click the [Stop] button of the target component.

A certain time is required for the start.

The start result can be verified by the LEDs on the target component. The result of the start operation is registered in the event log.

Sample screen of ft server utility

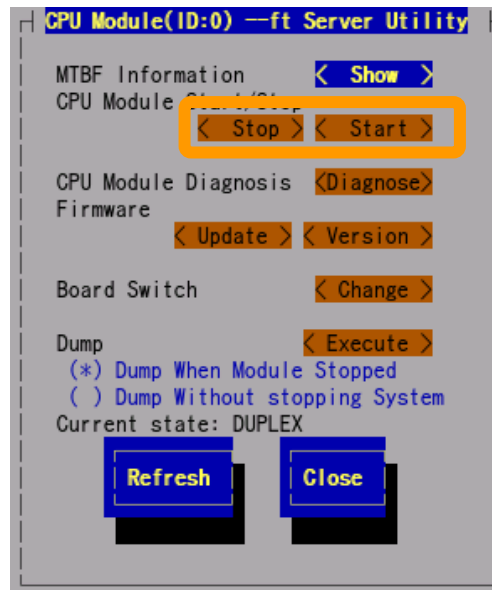
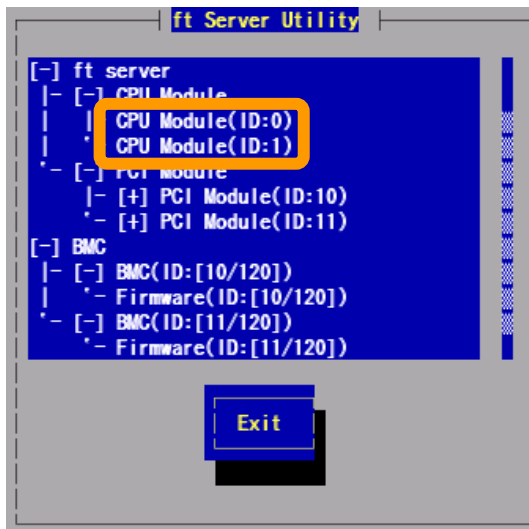

Check and Clear of MTBF Information

The MTBF information of a component can be viewed or cleared (initialized).

NEC Express5800/ft series manages the MTBF (mean time between failure) of each component. If a fault occurs in a component, the NEC Express5800/ft series calculates the MTBF of the component again. If the calculated value is lower than the pre-defined threshold, the NEC Express5800/ft series disables the component to be used.

Contact your maintenance personnel if such a symptom as above occurs.

The table below shows in which Fault Class a component can check.

Component	Check of MTBF Information	
	Remote	Local
CPU Module	Fault Class: uncorrectable	Fault Class: correctable uncorrectable microsync* * The current version does not support it.
PCI Module	Fault Class: uncorrectable	Fault Class: uncorrectable

Remote: Executable from remote management PC by using NEC ESMPRO Manager

Local: Executable on local server by using ft server utility

–: Not support

IMPORTANT: A disabled component with the MTBF lower than the threshold can be forcibly enabled by clearing the MTBF. However, contact your maintenance personnel for the forced use of such a component.

To clear the MTBF information of a component with NEC ESMPRO Manager, use the [Maintenance] tree of the component of the [ft] tree of the DataViewer. Open the tree of the component whose MTBF information is to be cleared and select the [Maintenance] tree.

To clear the MTBF information of a component with the ft server utility, use the utility screen of the component. The table below shows the potential cases in which the MTBF information of a component is to be cleared. Contact your maintenance personnel for clearing MTBF information.

Component	MTBF clear	
	Remote	Local
CPU Module	To start the module forcibly after replacing a module or if MTBF became lower than the threshold due to malfunction and disabled the module. Executable in the following module state (this can be viewed on manager screen): <ul style="list-style-type: none"> Broken MTBF is lower than the threshold.	To start the module forcibly after replacing a module or if MTBF became lower than the threshold due to malfunction and disabled the module. Executable in the following module state: <ul style="list-style-type: none"> The amber LED is on. The event indicating that MTBF is lower than the threshold is registered in the event log.
PCI Module	Same as above	Same as above

Remote: Executable from remote management PC by using NEC ESMPRO Manager

Local: Executable on local server by using ft server utility

–: Not support

IMPORTANT: You can also clear MTBF information for the PCI module, Ethernet Adapter and SCSI Adapter by unplugging and plugging the live wire of the PCI module.

Procedure in NEC ESMPRO Manager

Perform the procedure below before replacement of a component.

1. Select the target component in the [ft] tree.
2. Check the current state with the “State” display on the target component screen.
3. Click the [MTBF Clear] button in the [Maintenance] screen for the target component.

You can verify the MTBF clearing result by confirming whether the reset is done when the number of fault becomes 0 on the MTBF information of the target component screen.

4. Start the component.

Sample screen of NEC ESMPRO Manager

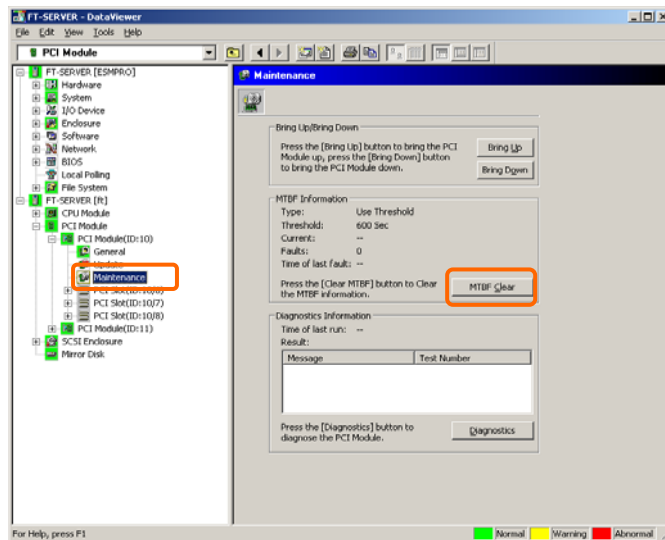

[Maintenance] screen of SCSI enclosure
[PCI module] – [Maintenance]

Procedure in the ft server utility

Perform the procedure below before replacement of a component.

1. Select the target component by using the ft server utility.
2. Check the current state of the target component with the LEDs and event log.
3. Click the [Show] button in [MTBF Information] of the target component.
4. Click the [Clear] button in [MTBF Clear] of the target component.
You can verify the MTBF clearing result by confirming whether the reset is done when the number of fault becomes 0 on the MTBF information of the target component screen.
5. Start the component.

Sample screen of ft server utility

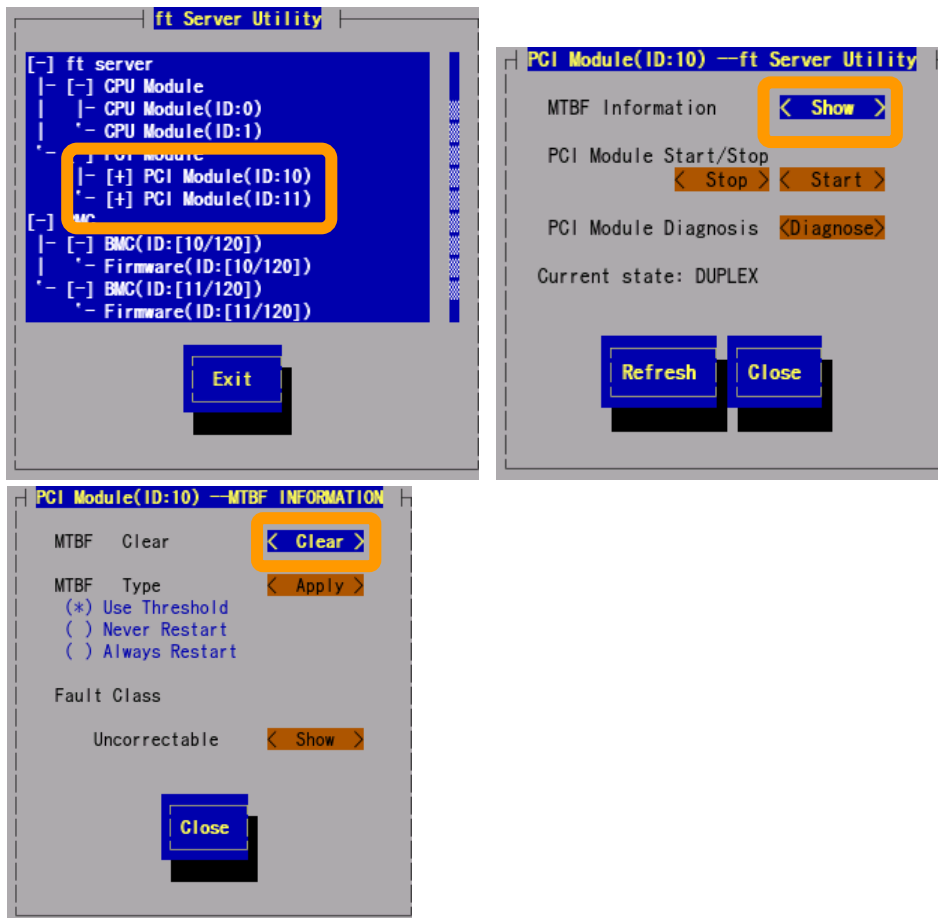

[PCI Module]

Diagnostics

The NEC Express5800/ft series provides the self-check diagnosis function for some components. If a fault occurs in a component, the NEC Express5800/ft series can diagnose the component to detect the fault.

To diagnose a component with the NEC ESMPRO Manager, use the [Maintenance] tree of the component in the DataViewer. Open the tree of the component to be diagnosed and select the [Maintenance] tree.

To diagnose of a component with the ft server utility, use the utility screen of the component.

However, the current version does not support this function.

Procedure in NEC ESM PRO Manager

1. Select the target component in the [ft] tree.
2. Check the current state with the “State” display on the target component screen. If the component is operating, stop the component.
3. Click the [Diagnostics] button in the [Maintenance] screen for the target component.

The diagnosis result can be verified by “Result” of the diagnosis on the target component screen. The result of the diagnosis is reported by the NEC Express5800/ft series as an alert.

The result of diagnosis executed last is displayed in the [Diagnosis Information] column. In addition, if a fault is detected by the result of the diagnosis, the state of the [General] tree of the component is changed.

Sample screen of NEC ESM PRO Manager

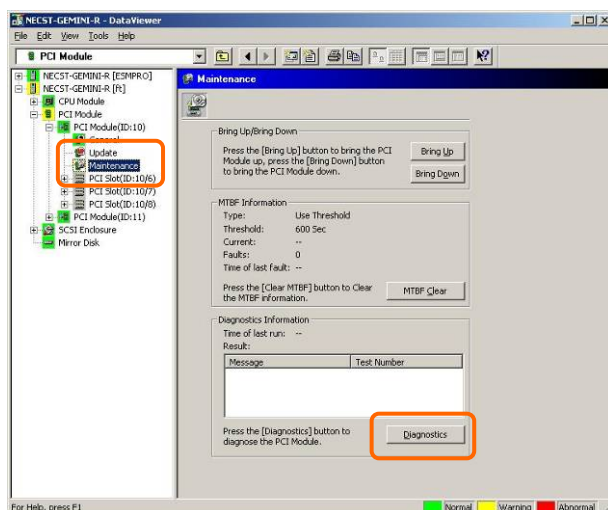

[Maintenance] screen of PCI module
[PCI Module] – [Maintenance]

Procedure in the ft server utility

1. Select the target component by using the ft server utility.
2. Check the current state of the target component with the LEDs. If the component is operating, stop the component.
3. Click the [Diagnostics] button in the [Diagnosis Information] on the target component.
The diagnosis result can be verified by the LEDs on the target component. The result of the diagnosis is registered in the event log.
4. Start the component.

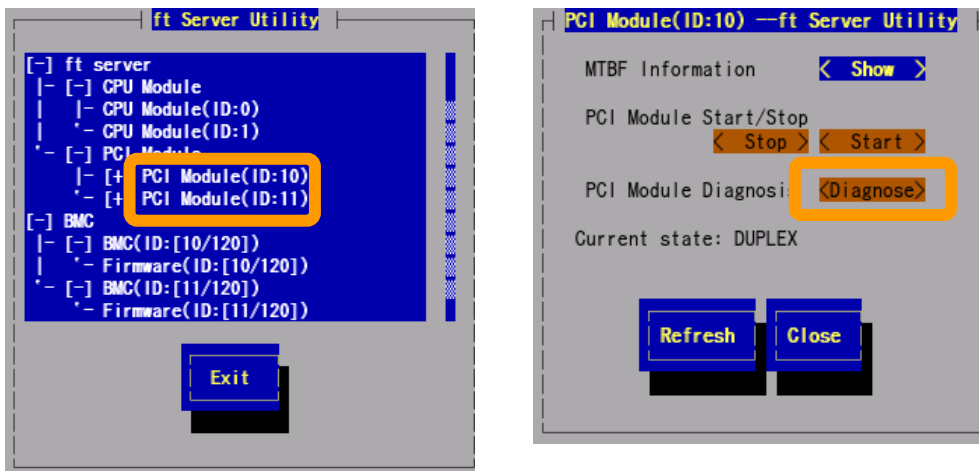
Sample screen of ft server utility

[PCI Module]

Firmware Update

NEC Express5800/ft series can update firmware (including BIOS) if some hardware components operate in the online state (in which the system continues the operation but the component trying to update firmware or BIOS is stopped).

To update firmware with NEC ESMPRO Manager, use the [Update] tree of the component in the DataViewer. Open the tree of the component for which firmware is updated and select the [Update] tree.

To update the firmware of a component with the ft server utility, use the utility screen of the component.

To update the firmware of a component, the firmware image file of the firmware for update must previously be stored in the managed server. On the firmware update screen, specify the path to the firmware image file for update.

The table below shows the potential cases in which the firmware of a component is to be updated.

Component	Firmware update	
	Remote	Local
CPU Module	<p>When BIOS must be updated to new one. Executable in any of the following module states (this can be viewed on manager screen):</p> <ul style="list-style-type: none"> • Removed • Broken or forced stop • No fault found by diagnosis <p>To update the module under operation, bring down the module before the update.</p>	<p>When BIOS must be updated to new one. Executable in the following module state:</p> <ul style="list-style-type: none"> • When the status LED 1 is amber and the status LED 2 is off. Only the status LED 1 illuminates amber when the module is in one of the following states: • Removed • Broken or forced stop • No fault found by diagnosis (Firmware Update Complete) <p>To update the module under operation, bring down the module before the update.</p>

Remote: Executable from remote management PC by using NEC ESMPRO Manager

Local: Executable on local server by using ft server utility

- : Not support

Procedure in NEC ESMPRO Manager

1. Save the image data of the update firmware in /etc/opt/ft/BIOS.ROM of the NEC Express5800/ft series.
2. Select the target component in the [ft] tree.
3. Check the current state with the “State” display on the target component screen. If the component is operating, stop the component.
4. Click the [Firmware Update] button in the [Update] screen for the target component.

Sample screen of NEC ESMPRO Manager

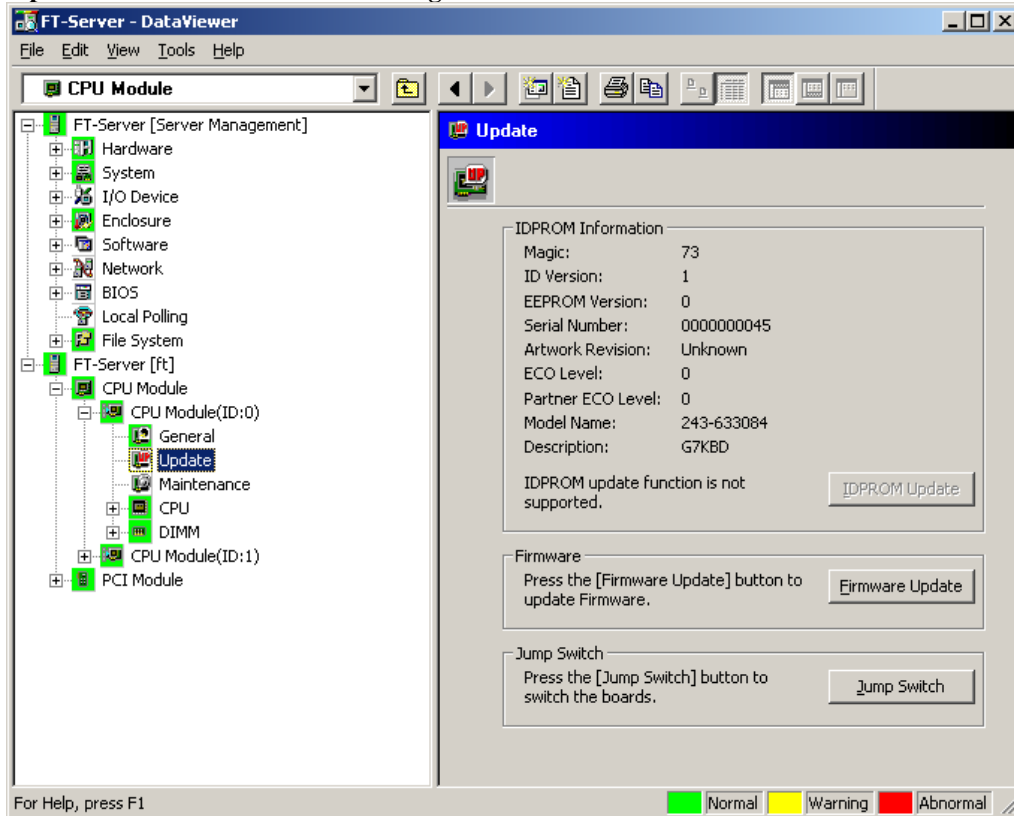

[Update] screen of CPU module
[CPU Module] – [Update]

5. Select [Specify the file path to update], enter the directory in which the updated firmware specified in the input box in step 1 is saved, and click the [Execute] button. Perform the firmware update. The update result can be verified by the state in the [General] screen for the target component (indication of “Firmware update completed”).

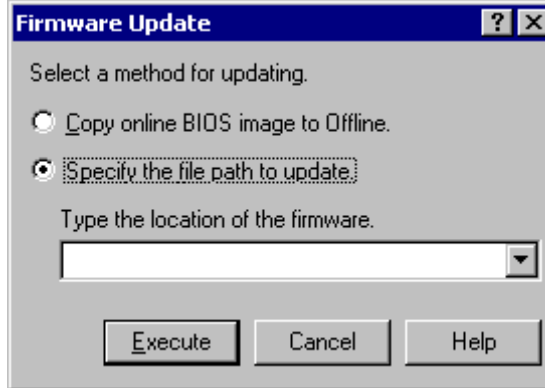

TIPS: No state changes when the firmware is not correctly updated. Please confirm whether the update file on the server is correctly stored in "/etc/opt/ft/BIOS.ROM".

6. After the BIOS for a single CPU module is completed, click the [Jump Switch] button. The module completely updated is started and the active module is stopped.
7. Start the other module stopped. Starting the module causes the firmware to be updated automatically.

However, if the [Enable automatic firmware update] property is invalid, update the module in the procedure as 3 to 5.

Procedure in ft server utility

1. Save the image data of the update firmware in /etc/opt/ft/BIOS.ROM of the NEC Express5800/ft series.
2. Select the target component in the [ft server] tree.
3. Check the current state of the target component with the LEDs. If the component is operating, stop the component.
4. Select the <Update> for the target component.

Sample screen of ft server utility

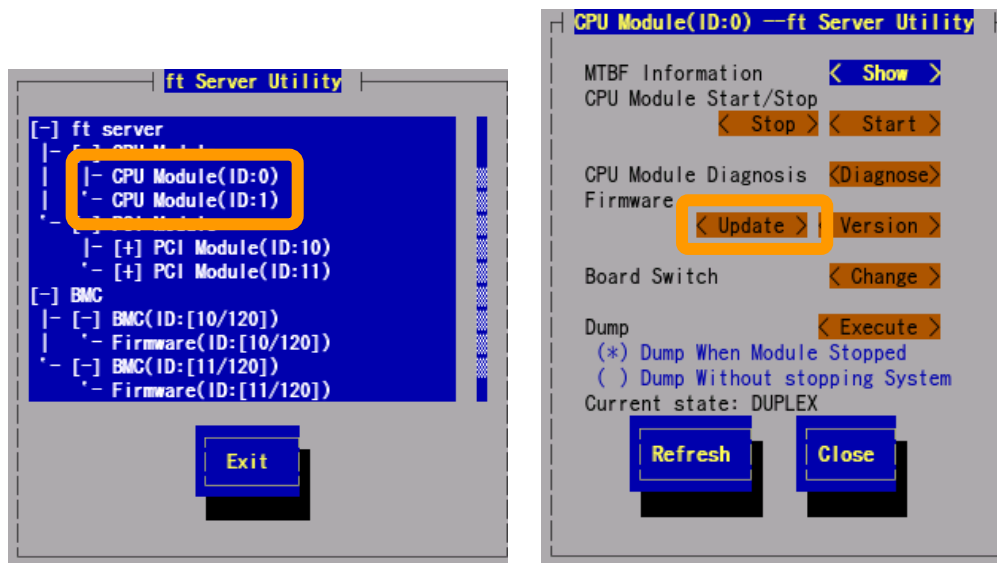

[CPU Module]

5. Select [File Path Update], and select the [Execute]. File path cannot be modified by the path (/etc/opt/ft/BIOS.ROM) in procedure 1. Perform the firmware update.

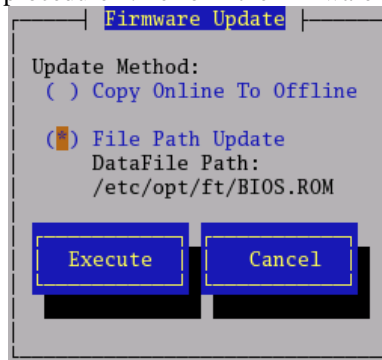

TIPS: No state changes when the firmware is not correctly updated. Please confirm whether the update file on the server is correctly stored in "/etc/opt/ft/BIOS.ROM". "Copy Online To Offline" does not support it. A module starts after copying it in Offline side from Online side by starting a stopping module.

6. After the BIOS for a single CPU module is completed, select the <Change>. The module completely updated is started and the module under operation is stopped.
7. Start the other module stopped. Starting the module causes the firmware to be updated automatically.

However, if failed automatically of update, update the module in the procedure as 3 to 5.

BMC Firmware Update

The firmware of the BMC on the PCI module can be updated. The BMC firmware can be updated by using the ft server utility. To update the BMC firmware, the firmware image file must previously be updated on the managed server. On the BMC firmware update screen, specify the pass of the image file of the firmware to be updated.

IMPORTANT: Contact your maintenance engineer for the update of the BMC firmware.

Component	BMC firmware update	
	Remote	Local
BMC	—	When update to new firmware is required.

Remote: Executable from remote management PC by using NEC ESMPRO Manager

Local: Executable on local server by using ft server utility

- : Not supported

Procedure in ft server utility

1. Save the image data of the update firmware in a desired directory of the NEC Express5800/ft series.
Write down the path to the directory in which the image data is saved.

IMPORTANT: Please save the file name by 1 to 255 characters length.

2. Select the target BMC #n of firmware #n in the [BMC] tree.
BMC #0 is BMC of the PCI module (ID:10), BMC #1 is BMC of the PCI module (ID:11).

3. Select <Update> of firmware update.
When update is started, the following messages are output by a syslog
kernel: EVLOG: INFORMATION - BMC nn/120, firmware burn starting.

TIPS: The case that the hues of the screen are different has newt using for the screen display by influence of packaging it, but an initial position with the firmware screen is a position of the “< Update >”.

Sample screen of ft server utility

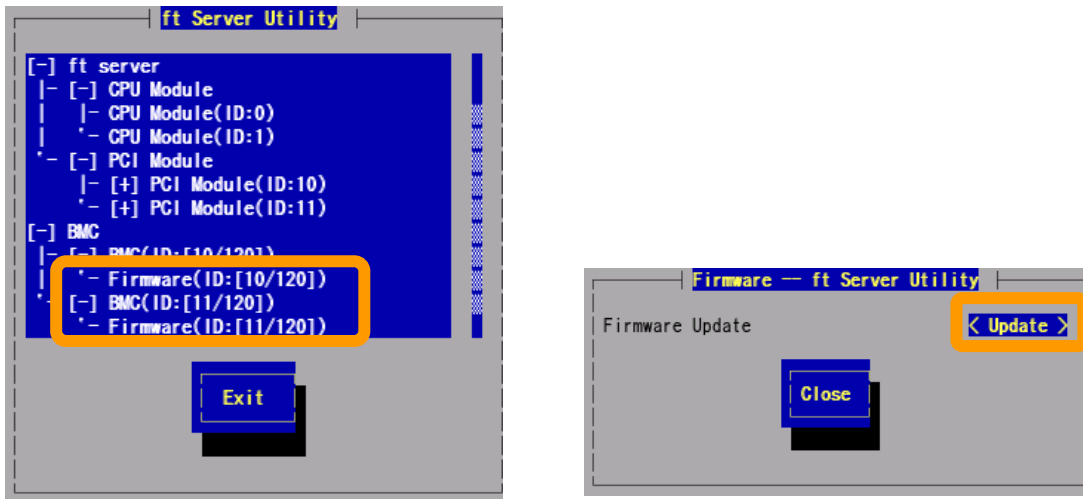

[BMC]

4. [Enter the file location of the new firmware] in the input box in step 1 is saved, and select the [Activate]. Perform the firmware update.

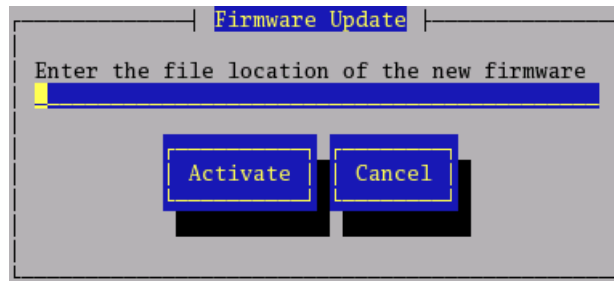

When update is completed, the following messages are output by a syslog.
kernel: EVLOG: INFORMATION - BMC nn/120, firmware burn succeeded

TIPS: When the following error message was displayed, please check the file location of the new firmware.

- The length of the file name must between 1 and 255 characters.
- Update file does not exist.

5. If the BMC firmware update of one CPU module is completed, you select other BMC, and

please update BMC firmware in a procedure same as procedure 4llection

To collect the dump file with NEC ESMPRO Manager, use [CPU Module] →[Maintenance] tree in the DataViewer.

To collect the dump with the ft server utility, use the utility screen of the component.

IMPORTANT: Acquire the dump only for the examination of a fault.

The dump can be collected in two ways. In each way, the dump file is stored under the directory of /var/crash/ on the server.

- Collecting dump of inactive module
The dump is acquired from the inactive CPU module (due to the occurrence of a fault or forced stop).
- Collecting dump under system operation
Either of the CPU modules is entered into the offline state and the dump is collected during system operation. After the acquisition, the CPU module is returned to the online state again. This can be done only in the duplex system.

However, this function is not supported in the current version.

Procedure in NEC ESMPRO Manager

The [Dump] button of NEC ESMPRO Manager performs the function of “saving dump during system operation.”

However, this function is not supported in the current version.

1. Select [CPU Module] in the [ft] tree.
2. Check the current state with the “State” display on the target component screen.
3. Click the [Dump] button in the [Maintenance] screen for the target component.

A certain time is required for the dump saving.

The dump is stored under the directory of /var/crash/ on the managed server.

The result of the dump saving is reported by the NEC Express5800/ft series as an alert.

Sample screen of NEC ESMPRO Manager

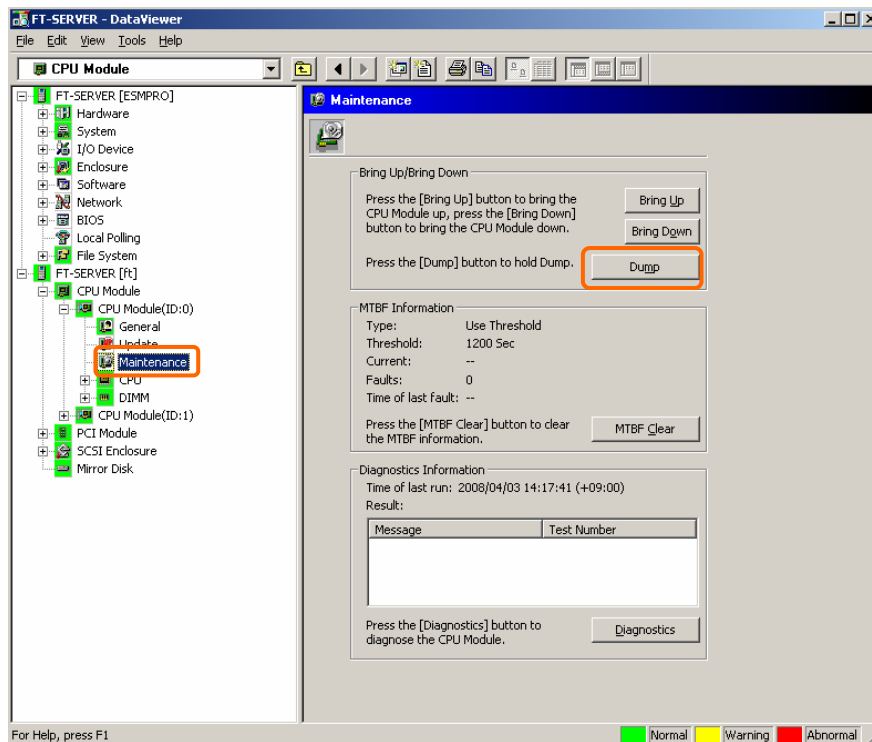

[Maintenance] screen of CPU module
[CPU Module] – [Maintenance]

Procedure in ft server utility

This function is not supported in the current version.

1. Select the target CPU module by using the ft server utility.
2. Check the current state of the target CPU module with the LEDs.
3. Select the dump acquisition method with [Dump] of the target CPU module and click the [Harvest] button.

A certain time is required for the dump acquisition.

The dump is stored under /var/crash/ directory on the server.

The result of the dump acquisition can be viewed in the syslog.

Sample screen of ft server utility

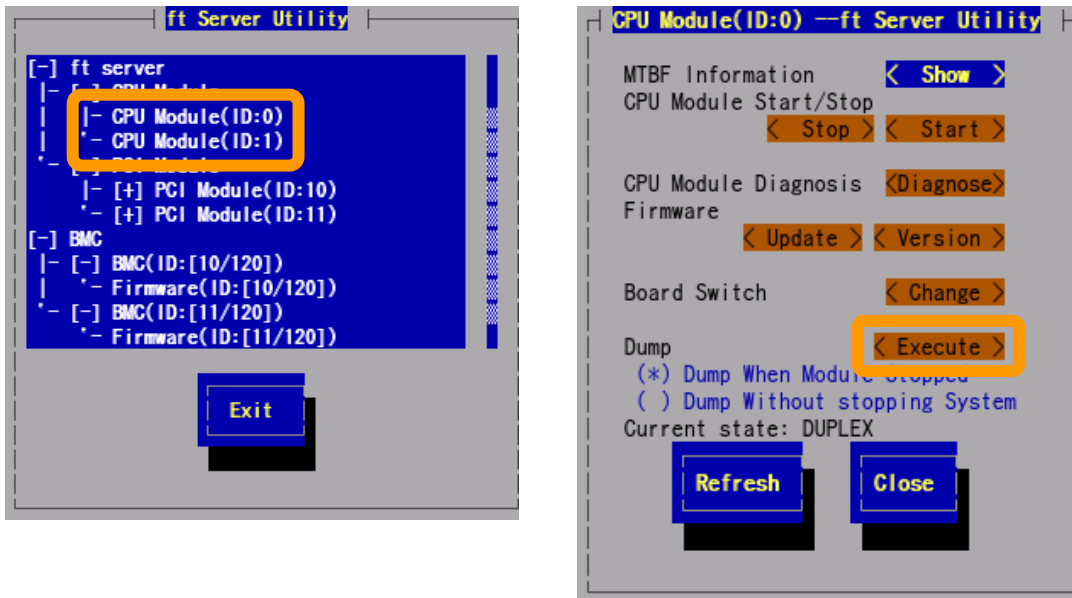

[CPU Module]

Refresh of View based on State Change Alert Setting

A new function is supported so that NEC ESMPRO Manager window will be updated on a system state change basis (in other words, whenever necessary). This function is OFF by default. See the [Setting] below about how to turn it ON.

NEC ESMPRO Manager window is updated by one minute-interval polling by default. Therefore, there is some time-lag for NEC ESMPRO Manager to recognize changes in NEC Agent. By using this function, the time-lag can be reduced. However, it may consume a little bit more network band width since each state change will be notified to NEC ESMPRO Manager as some kind of alert.

[Setting]

1. Select [Program] - [NEC ESMPRO Manager] from the Start menu and click [Manager Settings].



[Manager Settings] dialog box

2. Check [Enable the State Change Alert Setting].
3. Click the [Agent Setting...] button.

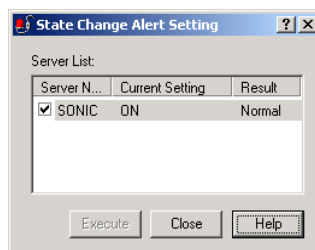

[State Change Alert Setting] dialog box

4. Check the name of servers sending the state change alert to the Manager when the Agent recognizes changes in the state.

Click the [Execute] button for the setting change to take effect.

NEC DianaScope

NEC DianaScope is software for remote management of NEC Express5800/ft series. For features and installation of NEC DianaScope, see “NEC DianaScope Online Document” in “NEC EXPRESSBUILDER.”

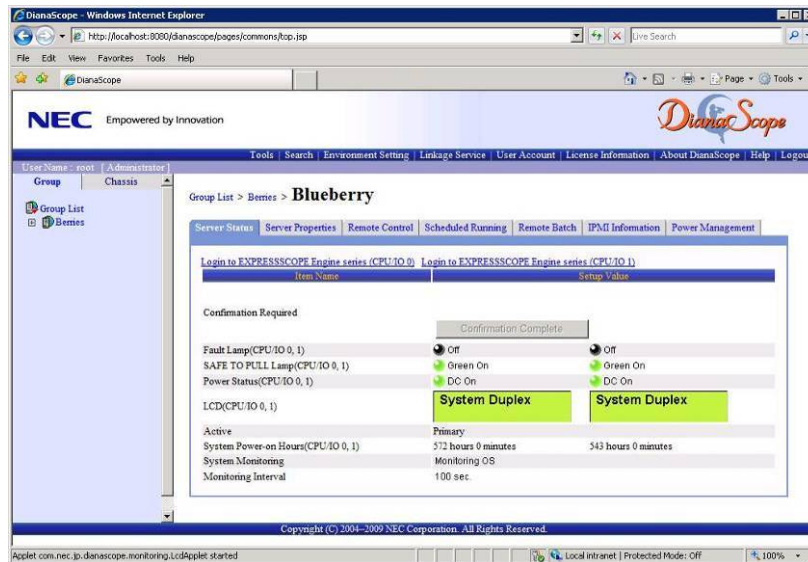

TIPS:

To use NEC DianaScope with NEC Express5800/ft series, appropriate server license is required.

- UL1198- 001E DianaScope Additional Server License (1)
License for managing one server.
- UL1198- 011E DianaScope Additional Server License (10)
License for managing ten servers.

This server comes with one license of NEC DianaScope.

Notes

The online document provides general descriptions of overall servers to be remotely managed by NEC DianaScope, but this section indicates notes that require special attention for remotely managing this server using NEC DianaScope.

- When remotely managing this server from NEC DianaScope, only LAN connection is available. Direct connection and connection via modem are not supported.
- NEC DianaScope cannot power off, power cycle or reset the server. NEC Express5800/ft series does not support such functions.

NEC PRODUCT INFO COLLECTION UTILITY

The NEC Product Info Collection Utility is used to collect various system configuration and log information for maintenance or troubleshooting purpose of the server. This utility can be installed from NEC EXPRESSBUILDER DVD.

NOTE: Supported Operating Systems of this utility is as follows.

- Windows Server 2003
 - Windows Server 2003 x64 Editions
-

Installation

You can install this utility according to the following procedure.

1. Insert NEC EXPRESSBUILDER DVD in the optical disk drive after OS starts.
2. Click from the menu displayed with Auto-run in order of [Setup software] – [Product Info Collection Utility].
3. The installation of this utility is started. Thereafter, install it according to the message in the dialog box. (In default, it is installed in "System drive: \ezclct" folder.)

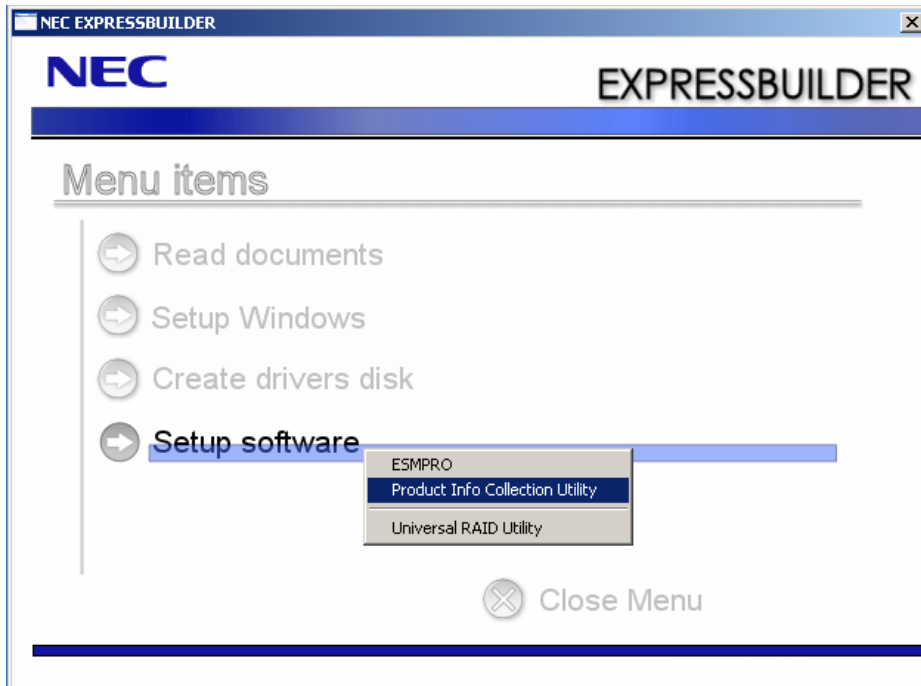

IMPORTANT:

Please log-in the system in account with the administrator authority.

2.5GB or more free space is required for the installation drive.

Using Utility

Execute `\stdclct\collect.exe` in the installation folder of this utility.

The log folder is made in the above-mentioned folder, and various information on this device is stored in the data compressed file (zip form).

Uninstallation

Choose [Add or Remove Programs] - [Product Info Collection Utility (Vx.x.x)] from the control panel. Thereafter, uninstall it according to the message in the dialog box.

(This page is intentionally left blank.)

Chapter 6

Maintenance

This chapter describes the daily maintenance of NEC Express5800/ft series and precautions when relocating or storing the server.

DAILY MAINTENANCE

To use your NEC Express5800/ft series in best condition, check and maintain regularly as described below. If an error is found on your NEC Express5800/ft series, consult your sales agent.

Checking Alert

Monitor the failure occurrence by NEC ESMPRO during the system operation.

Always check whether any alert is reported to NEC ESMPRO Manager on the management PC. Check whether any alert is reported on the Operation Window, DataViewer, or Alert Viewer of NEC ESMPRO Manager.

Viewers of NEC ESMPRO



Operation Window

Severity	Type	Manager	Component	Address	Received
Info	Slot State	mg_199427	199427	140.0.0.27	02/14/2000
Info	Slot State	mg_199427	199427	140.0.0.27	02/14/2000
Info	Power eventlog	mg_199427	199427	140.0.0.27	02/14/2000
Info	Power Unit Redu...	mg_199427	199427	140.0.0.27	02/09/2000
Info	Power Unit Reco...	mg_199427	199427	140.0.0.27	02/09/2000
Info	Power Supply Error	mg_199427	199427	140.0.0.27	02/09/2000
Info	Power Supply Error	mg_199427	199427	140.0.0.27	02/09/2000

Alert Viewer

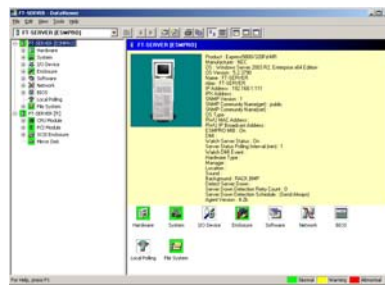

Data Viewer

Checking STATUS LEDs

Check the LED indication on the front of the NEC Express5800/ft series, on hard disks installed in 3.5-inch hard disk drive bay, or on LCD display when the server is powered on or powered off by the shut down operation. The functions and indications of LEDs are described in Chapter 2. If any indication that shows an error, contact your sales agent.



Making Backup Copies

NEC recommends you make backup copies of your valuable data stored in hard disks of the server on a regular basis. For backup storage devices suitable for the server and backup tools, consult with your sales agent.

When you have changed the hardware configuration or BIOS configuration, select "System Information Management" and then "Save" of the Off-line Maintenance Utility to make a backup copy of the system information.

Cleaning

Clean the server on a regular basis to keep the server in a good shape.

 WARNING	
	<p>Observe the following instructions to use the server safely. There are risks of death or serious personal injury. See "PRECAUTIONS FOR SAFETY" in Chapter 1.</p> <ul style="list-style-type: none">• Do not disassemble, repair, or alter the server.• Do not look into the DVD-ROM drive.• Disconnect the power plug before cleaning the server.

Cleaning the NEC Express5800/ft series

For daily cleaning, wipe the external surfaces of the server with a dry soft cloth. Follow the procedure below if stains remain on the surfaces:

IMPORTANT:

- To avoid altering the material and color of the server, do not use volatile solvents such as thinner or benzene to clean the server.
 - The power receptacle, the cables, the connectors on the rear panel of server, and the inside of the server must be kept dry. Do not moisten them with water.
-

1. Make sure that the server is powered off.
2. Unplug the power cord of the server from a power outlet.
3. Wipe off dust from the power cord plug with a dry cloth.
4. Soak a soft cloth in neutral detergent that is diluted with cold or warm water, and squeeze it firmly.
5. Rub off stains on the server with the cloth prepared in Step 4.
6. Soak a soft cloth in water, squeeze it firmly and wipe the server with it once again.

7. Wipe the server with a dry cloth.
8. Wipe off dust from the fan exhaust opening on the rear of the server with a dry cloth.

Cleaning the Keyboard and Mouse

IMPORTANT:

A keyboard and a mouse use USB interface. Therefore it is not necessary to power off the server when connecting or disconnecting them.

Disconnect the keyboard from the server while the devices in the system (the server and the peripheral devices) remain turned on. Wipe the keyboard surface with a dry cloth. Then connect the keyboard to the server.

The mouse operation depends on the degree of smoothness of the internal ball rotation. To keep the mouse ball clean, use the mouse in a place with little dust. Follow the steps below to clean the mouse regularly:

1. Disconnect the mouse from the USB port of the keyboard while the server remains powered on.
2. Turn the mouse upside down, and rotate the mouse ball cover counterclockwise to remove it. Take out the ball from the mouse.

3. Wipe the mouse ball with a dry soft cloth.
If stains remain, use a soft cloth to wipe them off. Soak the soft cloth in neutral detergent that is diluted with water or warm water, and squeeze it firmly.

4. Wipe three small rollers inside the mouse with cotton swab.
Use the cotton swab soaked with alcohol if stains remain.

5. Put the mouse ball back into the mouse.
If the mouse or rollers are wet in steps 3 and 4, put it back after fully dried.

6. Place the mouse ball cover, and rotate it clockwise until it is locked.

7. Connect the mouse to the server .

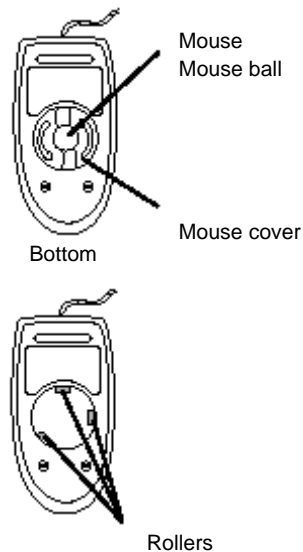

Cleaning the Floppy Disk Drive

A read/write error may occur due to stains on the read/write head of the floppy disk drive.

Use the cleaner dedicated for floppy disk drive to clean the read/write head. It is recommended to clean the head on regular basis.

Cleaning DVD/CD-ROM

A dusty DVD/CD-ROM or dust-accumulated tray causes the device to fail to read data correctly.

Follow the procedure below to clean the tray and DVD/CD-ROM regularly:

1. Make sure that the server is powered on.
2. Press the Eject button on the front of the DVD-ROM drive.
The tray comes out.
3. Hold the DVD/CD-ROM lightly and take it out from the tray.

IMPORTANT: Do not touch the signal side of the DVD/CD-ROM with your hand.

4. Wipe the tray with a dry soft cloth.

IMPORTANT: Do not wipe the lens of the DVD-ROM drive. Doing so may damage the lens and may cause a malfunction of the drive.

5. Gently push on the tray front to close the tray.
6. Wipe the signal side of the CD/DVD-ROM with a dry soft cloth.

IMPORTANT: Wipe DVD/CD-ROMs from the center to the outside. Use only CD-ROM cleaner if necessary. Cleaning a DVD/CD-ROM with record spray/cleaner, benzene, or thinner causes damage to the DVD/CD-ROM contents. At worst, inserting the DVD/CD-ROM into the server may cause failure.

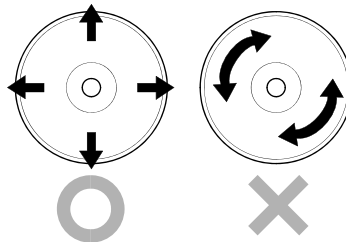

Cleaning Tape Drive

Dirt on the tape head may be a cause of unsuccessful backup and damage to tape cartridge. Clean the tape head regularly using a cleaning tape. For procedure and interval of cleaning as well as lifetime of a tape cartridge to use, see instructions included with the tape drive.

SYSTEM DIAGNOSTICS

The System diagnostics runs several tests on the server.

Select [Tool menu] - [Test and diagnostics] in the NEC EXPRESSBUILDER to diagnose the system.

Test Items

The following items are tested in system diagnostics.

- Memory
- CPU cache memory
- Hard disk drive used as a system

IMPORTANT: When executing the system diagnostics, make sure to remove the LAN cable. Executing the system diagnostics with the LAN cable connected, the network may be influenced.

TIPS: On checking the hard disk drive, no data is written into the disk.

Startup and Exit of System Diagnostics

Follow the steps below to start the system diagnostics. (If the server is running, shut it down, and execute Step 1 through Step 12.)

1. Shutdown the OS, and power off the server. Then, unplug the power cord.
2. Disconnect all the LAN cables from the server.
3. Plug the power cord and power on the server.
4. Use the NEC EXPRESSBUILDER DVD to start the system.
5. Select [Tool menu].

TIPS: If the system displays the [Language Selection] menu, select [English].

6. Select [Test and diagnostics].

Select [End-User Mode] and the system diagnostics starts. The diagnostics will be completed in approximately three minutes.

When the diagnostics is completed, the screen of the display changes as shown below:

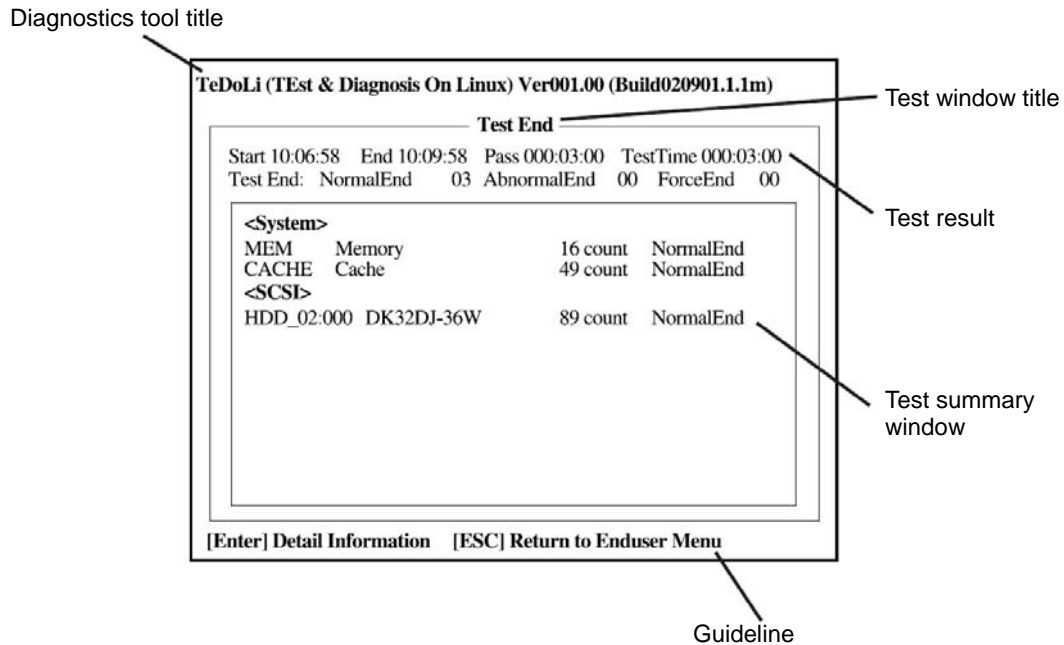

Diagnostics tool title

Shows the name and version of the diagnostic tool.

Test window title

Shows the progress of the diagnostics. "Test End" is displayed when the diagnostics completes.

Test result

Shows the start, end, and elapsed time and completion status of the diagnostics.

Guideline

Shows the details of the keys to operate window.

Test summary window

Shows the results of each test that executed the diagnostics. Move the cursor and press the **Enter** key on the cursor line to display the details of the test.

When an error is detected by the system diagnostics, the relevant test result in the test summary window is highlighted in red, and "Abnormal End" is displayed in the result on the right side.

Move the cursor to the test that detected the error, and press the **Enter** key. Record the error message that has been output to the Detail Information screen and contact your sales agent.

7. Follow the guideline shown at the bottom of the screen, and press the **Esc** key.

The [Enduser Menu] below is displayed.

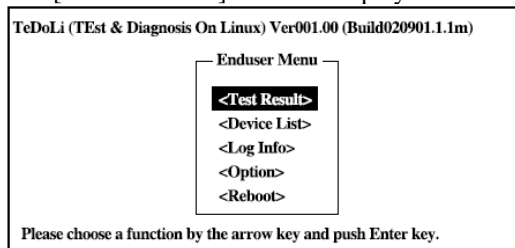

<Test Result>

Shows the diagnostics completion screen of the above diagnostics.

<Device List>

Shows a list of connected devices.

<Log Info>

Shows the log information of the diagnostics. Log information can be saved. To save it, connect a FAT formatted removable media, and select <Save(F)>.

<Option>

Optional features can be used from this menu.

<Reboot>

Reboots the system.

8. Select <Reboot> in the [Enduser Menu] above.
The server restarts and the system is started from the NEC EXPRESSBUILDER.
9. Exit the NEC EXPRESSBUILDER, and remove the DVD from the optical disk drive.
10. Power off the server and unplug the power cord from the receptacle.
11. Reconnect all the LAN cables that have been disconnected in Step 2 to the server.
12. Plug the power cord.

This completes the system diagnostics.

MAINTENANCE TOOLS

The Maintenance Tools is a tool of this product for preventive maintenance, as well as for trouble analysis and its settings. Follow the below procedure to start the Maintenance Tool.

Starting the Off-line Maintenance Utility

The Off-line Maintenance Utility may be started in the following ways.

1. Boot peripheral devices at first, then power on the Express server.
2. Load the [EXPRESSBUILDER] DVD into the optical disc drive of the Express server.
3. After loading the DVD, reset (by pressing <Ctl> + <Alt> + <Delete> keys) or power off and on to reboot the Express server.
Following menu appears on the DVD.

Tool Menu:
Select this to launch the Off-line
Maintenance Utility.



- 4. Select [Tool Menu].
Following Language selection menu appears.

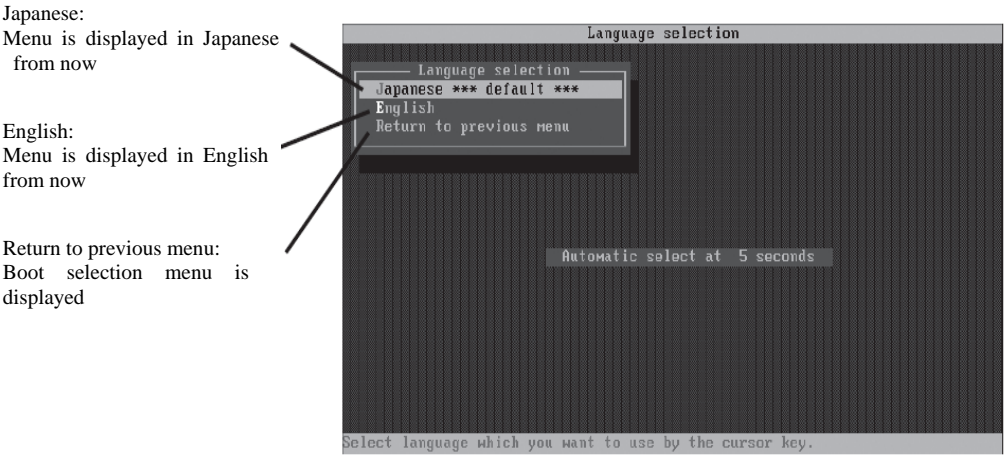

IMPORTANT:

Default menu selection is [Japanese]. When there is no key operation for five second after Language menu appears, [Japanese] starts automatically.

- 5. Select [English]
When [English] is selected, following tool menu appears.

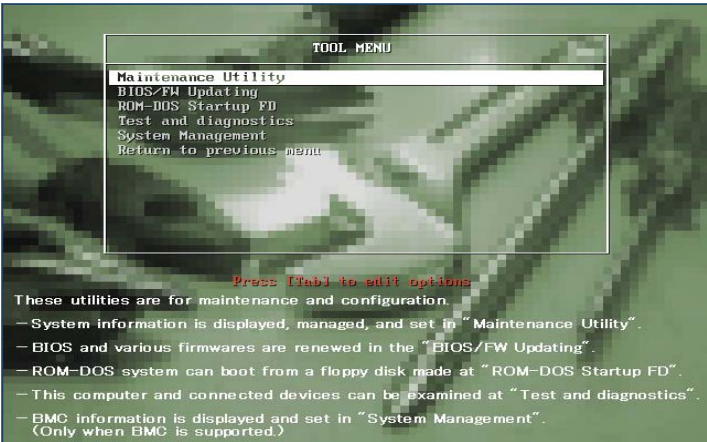

- 6. Select one of the tool and start.

Function of Maintenance Tools

The following functions are available in the Maintenance Tools.

- Maintenance Utility

The Off-line Maintenance Utility is started in “Maintenance Utility.” The Off-line Maintenance Utility is an OS-independent maintenance program. When you are unable to start the OS-dependent NEC ESMPRO to troubleshoot a problem, the Off-line Maintenance Utility can be used.

IMPORTANT:

- The Off-line Maintenance Utility is intended for use of your service representative. The NEC EXPRESSBUILDER DVD contains a file that describes the operation of the utility, but do not attempt to use the utility by yourself. Contact your service representative and follow their instructions.
 - See the on-line help for details for the Off-line Maintenance Utility. For further information, ask your service representative.
-

The Off-line Maintenance Utility provides the following features.

- IPMI Information Viewer

Provides the functions to view the system event log (SEL), sensor data record (SDR), and field replaceable unit (FRU) and to make a backup copy of them.

Using this feature, you can find system errors and events to determine a maintenance part.

- BIOS Setup Viewer

Provides the functions to export the current configuration data defined with the SETUP utility to a text file.

- System Information Viewer

Provides the functions to view and information on the processor (CPU) and on the BIOS. You can export the information to a text file.

- System Information Management

Provides the function to make a back-up copy of your data.

Without the backup data, the system-specific information and/or configuration may not be restored.

Only the authorized service maintenance staff is allowed to restore the backup data.

- System Management

The parameters of BMC (Baseboard management Controller) are set for remote control and alert.

- BIOS/FW Updating

This menu allows you to update the software module such as BIOS and firmware of the server by using the update disk (3.5-inch floppy disk) that is distributed from NEC customer service representative.

After rebooting the system, an update program is started automatically from floppy disk, and the various BIOS and firmware programs are updated.

IMPORTANT:

Do not turn off the server while the update program is running. If the update processing is discontinued, the system becomes unable to start.

- ROM-DOS startup FD

Create a support disk for starting the ROM-DOS system.

- Test and diagnostics

Execute various tests on the server system to check if the server functions are normal and if the connection between the server and additional board is normal.

After the Test and diagnostics is executed, a system check program assigned to each model starts.

- System Management

The parameters of BMC (Baseboard Management Controller) are set for remote control and alert.

This menu's function is the same as the "System Management" of the "Maintenance Utility."

RELOCATING/STORING THE NEC EXPRESS5800/FT SERIES

Follow the procedure below to relocate or store the server.

⚠ CAUTION	
	<p>Observe the following instructions to use the server safely. There are risks of fire, personal injury, or property damage. See "PRECAUTIONS FOR SAFETY" in Chapter 1 for details.</p> <ul style="list-style-type: none">• Never attempt to lift the server only by yourself.• Do not install the server in any place other than specified.• Do not connect/disconnect any interface cable with the power cord of the server plugged to a power source.

IMPORTANT:

- If the server needs to be relocated/stored due to a change in the floor layout to a great extent, contact the sales agent.
- Make sure to make a backup copy of your valuable data in the hard disk, if any.
- When moving the server with hard disks, make sure not to give a shock to the hard disks.
- When storing the server, keep it under storing environment conditions (temperature: -10 to 55°C, humidity: 20 to 80%, non-condensing).

1. Take a floppy disk and a DVD out of the server, if any.
2. Power off the server.
3. Unplug the power cord of the server from a power outlet.
4. Remove all the cables from the server.
5. Remove all the mounted CPU/IO modules.
6. Remove the 4U chassis and the rails from the rack cabinet.
7. Carry 4U chassis and CPU/IO modules separately.
8. Protect the server with the shock-absorbing materials, and pack it securely.

IMPORTANT:

Check and adjust the system clock before operating the server again after relocating or storing it.

If the server and the built-in optional devices are moved from a cold place to a warm place in a short time, condensation will occur and cause malfunctions and breakdown when these are used in such state. When you start operating these equipments again after the transportation or the storage, make sure to wait for a sufficient period of time to use them in the operating environment.

If the system clock goes out of alignment remarkably as time goes by, though the system clock adjustment is performed, contact your sales agent.

(This page is intentionally left blank.)

Chapter 7

Troubleshooting

This section covers some of the issues that can occur with this server, and provides the troubleshooting steps you can refer to.

TO LOCATE THE ERRORS

Use NEC ESMPRO to monitor the occurrence of fault during the system operation.

Especially take note on whether any alert is reported to NEC ESMPRO Manager on the management PC. Check whether any alert is reported on the Operation Window, DataViewer, or Alert Viewer of NEC ESMPRO Manager.

[Example]

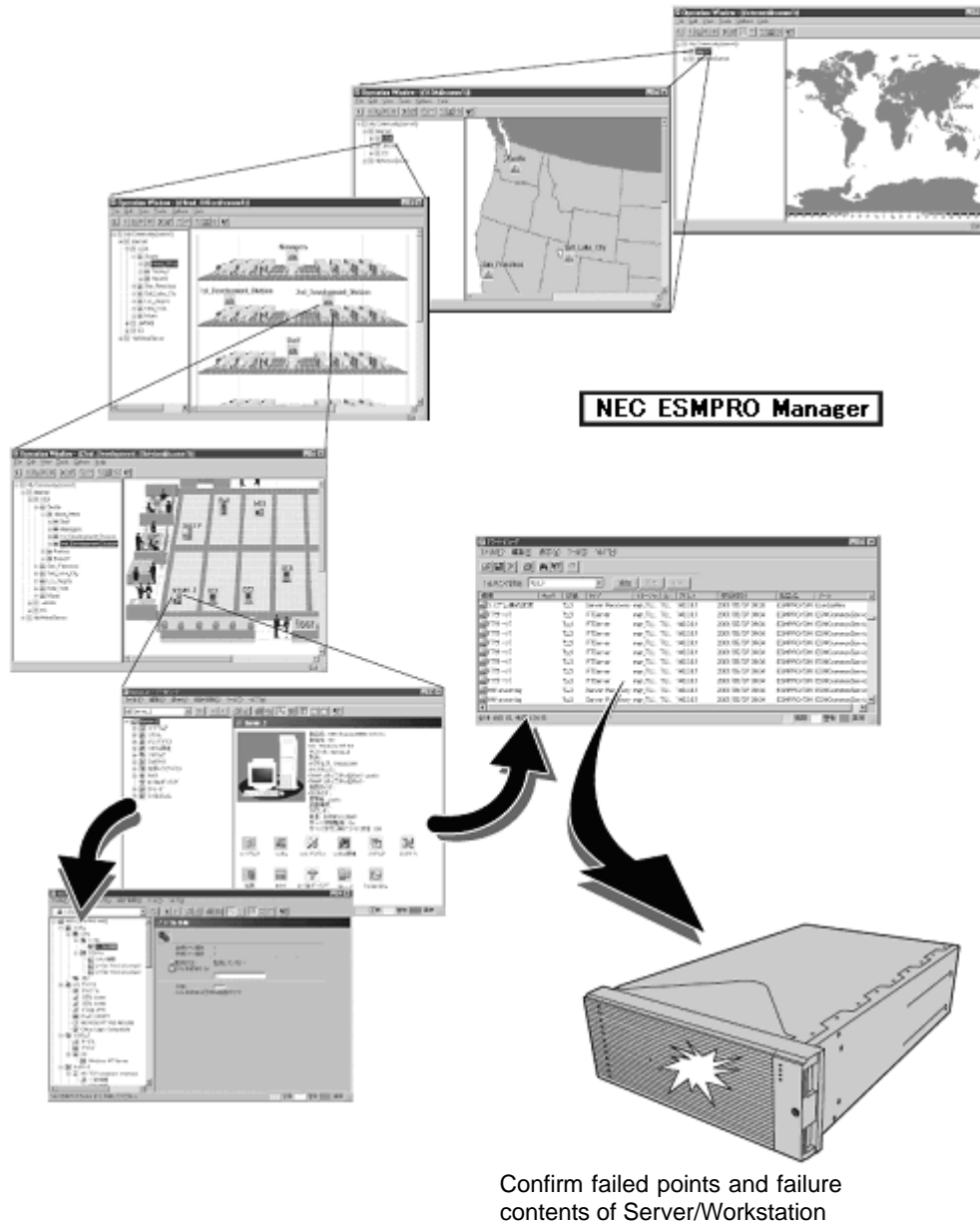

Confirm failed points and failure contents of Server/Workstation

ERROR MESSAGES

If the NEC Express5800/ft series enters the abnormal state, the error is posted by various means. This section explains the types of error messages.

Error Messages by LED Indication

The LEDs on the front and rear panels of the NEC Express5800/ft series and near the handles of hard disks inform the user of the various server statuses by the colors and the patterns of going on, going off, and flashing. If trouble seems to have occurred, check the LED indication. For the LED indication and meanings, see page 2-17 “EXPRESSSCOPE.”

This User’s Guide describes actions to be taken for watch error message. However, if replacement of modules is necessary, contact your sales agent.

POST Error Messages

Powering on the server automatically starts the self-diagnostic program, POST (Power On Self-Test). When POST detects any error, it displays an error message and its measure on the display unit. Follow the table below to troubleshoot such errors.

```
Phoenix BIOS 4.0 Release 6.0.XXXX
:
CPU=Pentium III XXX MHz
0640K System RAM Passed
0127M Extended RAM Passed
WARNING:
02B0: Diskette drive A error.
:
press <F1> to resume, <F2> to SETUP
```

Message indicating a floppy disk drive error

TIPS:

For error messages on optional PCI boards, refer to the manual provided with those options.

On-screen error message	Cause	Action
0200 Failure Fixed Disk	<ul style="list-style-type: none"> HDD is faulty CPU/IO module is faulty. 	<ul style="list-style-type: none"> Replace the HDD. Replace the CPU/IO module.
0210 Stuck Key	Keyboard connection error	<ul style="list-style-type: none"> Disconnect the keyboard and connect it back again. Replace the keyboard.
0211 Keyboard error	Keyboard is faulty.	<ul style="list-style-type: none"> Disconnect the keyboard and connect it back again. Replace the keyboard. If restarting does not help, replace the CPU/IO module.
0212 Keyboard Controller Failed	Keyboard controller is faulty.	If restarting the server does not help, replace the CPU/IO module.
0213 Keyboard locked - Unlock key switch	Keyboard is locked.	Unlock the key switch.
0230 System RAM Failed at offset	DIMM is faulty.	<ul style="list-style-type: none"> Replace DIMM. Replace the CPU/IO module.
0231 Shadow RAM Failed at offset	Shadow RAM is faulty.	<ul style="list-style-type: none"> Replace DIMM. Replace the CPU/IO module.
0232 Extended RAM Failed at address line	Extended RAM is faulty.	<ul style="list-style-type: none"> Replace DIMM. Replace the CPU/IO module.
0233 Memory type mixing detected	Memory of the different types is installed.	Memory of the different types is installed. Replace DIMM with appropriate one.
0250 System battery is dead -Replace and run SETUP	System battery is dead.	<ul style="list-style-type: none"> Replace system battery. Replace CPU/IO module.
0251 System CMOS checksum bad-Default configuration used	System CMOS configuration is changed.	Reconfigure the system CMOS by using BIOS setup.

On-screen error message	Cause	Action
0252 Password checksum bad -Password cleared	Password is cleared.	Reconfigure by using BIOS setup.
0260 System Timer error	System Timer is faulty.	Reconfigure by using BIOS setup. If the error cannot be solved after this, replace the CPU/IO module.
0270 Real time clock error	RTC is faulty.	
0271 Check date and time setting	Date and time are incorrectly set.	
02D0 System cache error - Cache disabled	CPU cache is faulty.	If replacing the CPU does not help, replace the CPU/IO module.
02D1 System Memory exceeds the CPU's caching limit	CPU cache is faulty.	
02F0 CPU ID	CPU is faulty	
0613 COM A configuration change	COM A configuration is faulty.	If restarting does not help after resetting the setting to default by using BIOS setup, replace the CPU/IO module.
0614 COM A config, error - device disable	Device constructing COM A is faulty.	
0615 COM B configuration change	COM B configuration is faulty.	
0616 COM B config, error - device disable	Device constructing COM A is faulty.	
0B28 Unsupported Processor detected on Processor 1	Unsupported CPU is mounted.	Check the supported CPU and replace it. If this does not help, replace the CPU/IO module.
0B29 Unsupported Processor detected on Processor 2	Unsupported CPU is mounted.	
0B80 BMC Memory Test Failed	RMC device is faulty.	Replace the CPU/IO module.
0B81 BMC Firmware Code Area CRC check failed		
0B82 BMC core Hardware failure		
0B83 BMC IBF or OBF check failed	RMC device is faulty.	Replace the CPU/IO module.
0B8B BMC progress check timeout	BMC check is suspended.	Replace the CPU/IO module.
0B8C BMC command access failed	BMC command access failed.	Replace the CPU/IO module.
0B90 BMC Platform Information Area corrupted	BMC device is faulty.	Replace the CPU/IO module.
0B91 BMC update firmware corrupted		
0B92 Internal Use Area of BMC FRU corrupted	Data within SROM is faulty.	Replace the system backboard.
0B93 BMC SDR Repository empty	SDR data is faulty.	If updating SDR does not help, replace the CPU/IO module.
0B94 IPMB signal lines do not respond	SMC is faulty.	Replace the CPU/IO module or a system backboard after determining where IPMB error has occurred based on OS information.
0B95 BMC FRU device failure	NVRAM within BMC is faulty.	Replace the CPU/IO module.

On-screen error message	Cause	Action
0B96 BMC SDR Repository failure	SDR repository within BMC is faulty.	Replace the CPU/IO module.
0B97 BMC SEL device failure	SEL repository within BMC is faulty.	
0B98 BMC RAM test error	BMC RAM is faulty.	
0B99 BMC Fatal hardware error	BMC FPGA is faulty.	
0B9A BMC not responding	BMC device is faulty.	
0B9B Private I2C bus not responding	I2C bus is faulty.	If turning AC power off and on does not help, replace the CPU/IO module or the system backboard.
0B9C BMC internal exception	BMC device is faulty.	Replace the CPU/IO module
0B9D BMC A/D timeout error		
0B9E SDR repository corrupt	SDR data is faulty.	If updating SDR does not solve the issue, replace the CPU/IO module.
0B9F SEL corrupt	SEL repository within BMC is faulty.	Replace the CPU/IO module
0BA0 SDR/PIA mismatched. SDR, PIA must be updated.	SDR and PIA data do not match.	If updating SDR/PIA does not solve the issue, replace the CPU/IO module.
0BB0 SMBIOS - SROM data read error	<ul style="list-style-type: none"> • I2C bus is faulty. • SROM is faulty. • BMC is faulty. 	If turning AC power off and on does not help, replace the system backboard.
0BB1 SMBIOS - SROM data checksum bad	Data within SROM is faulty.	
0BC0 POST detected startup failure of 1st Processor	CPU is faulty.	Replace the CPU.
0BC1 POST detected startup failure of 2nd Processor		
8100 Memory Error detected in DIMM group #1	DIMM is faulty.	Replace DIMM slot 1 and 2.
8101 Memory Error detected in DIMM group #2		Replace DIMM slot 3 and 4.
8102 Memory Error detected in DIMM group #3		Replace DIMM slot 5 and 6.
8103 Memory Error detected in DIMM group #4		Replace DIMM slot 7 and 8.
8104 Memory Error detected in DIMM group #5		Replace DIMM slot 9 and 10.
8105 Memory Error detected in DIMM group #6		Replace DIMM slot 11 and 12.
8120 Unsupported DIMM detected in DIMM group #1	Non-supported DIMM is mounted.	Check the supported DIMM and replace the DIMM. If replacing the DIMM does not help, replace CPU/IO module.
8121 Unsupported DIMM detected in DIMM group #2		

On-screen error message	Cause	Action
8122 Unsupported DIMM detected in DIMM group #3	Non-supported DIMM is mounted.	Check the supported DIMM and replace the DIMM. If replacing the DIMM does not help, replace CPU/IO module.
8123 Unsupported DIMM detected in DIMM group #4		
8124 Unsupported DIMM detected in DIMM group #5		
8125 Unsupported DIMM detected in DIMM group #6		
8130 Mismatch DIMM detected in DIMM group #1	DIMM types do not match.	
8131 Mismatch DIMM detected in DIMM group #2		
8132 Mismatch DIMM detected in DIMM group #3		
8133 Mismatch DIMM detected in DIMM group #4		
8134 Mismatch DIMM detected in DIMM group #5		
8135 Mismatch DIMM detected in DIMM group #6		
8150 NVRAM Cleared By Jumper		
8151 Password Cleared By Jumper	Password clear jumper is mounted.	
8160 Mismatch Processor Speed detected on Processor 1	CPU frequency does not match.	Check supported CPUs and replace them. If replacing the CPU does not help, replace CPU/IO module.
8161 Mismatch Processor Speed detected on Processor 2		
9000	A serious error occurred during a POST.	There are some error messages in addition to this error code. Check the other error message.
9002 Memory not installed.	DIMM is not implemented. DIMM is faulty.	Mount or replace the DIMM.
9003 Memory implementation error detected	Error is detected on memory implementation.	Check supported DIMMs and replace the DIMM. If replacing the DIMM does not help, replace the CPU/IO module.

On-screen error message	Cause	Action
9006 HW Memory Test failed.	Memory is faulty.	Replace the DIMM. If replacing it does not help, replace the CPU/IO module.
9064 Mixed CPU Steppings detected.	Different CPU steppings are found.	Check supported CPUs and replace them. If replacing the CPU does not help, replace CPU/IO module.
9090-9097	A memory error has occurred, or memory is faulty.	(a) Verify that the memory is mounted properly. (b) Replace the memory. If this does not help, replace the module.

Server Management Application Error Message

If the server management tool such as NEC ESMPRO Agent or NEC ESMPRO Manager has been installed in the NEC Express5800/ft series or management PC, you can obtain the error information from the display unit of the server or management PC.

See Chapter 5 or online documentation for details of such application programs.

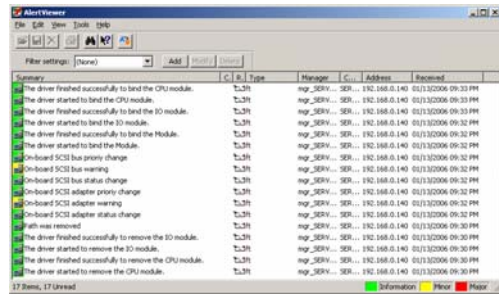

TROUBLESHOOTING

When the server fails to operate as expected, see the following to find out your problem and follow the given instruction before asking for repair.

If the server still fails to operate successfully after solving your problem, take a note on the on-screen message and contact your sales agent.

Problems with NEC Express5800/ft series

Fail to power on the server:

- Is the server properly supplied with power?
 - Check if the power cord is connected to a power outlet (or UPS) that meets the power specifications for the server.
 - Check if the two pieces of the provided power cord are connected to the main unit properly.
 - Make sure to use the power cord provided with the server. Check the power cord for broken shield or bent plugs.
 - Make sure the power breaker for the connected power outlet is on.
 - If the power cord is plugged to a UPS, make sure the UPS is powered and it supplies power. See the manual that comes with the UPS for details.

Power supply to the server may be linked with the connected UPS using the BIOS setup utility of the server.

<Menu to check: [Server] - [AC-LINK] - [Power On]>
 - Make sure the POWER switch on the power unit is on.
- Did you press the POWER switch?
 - Press the POWER switch on the front of the NEC Express5800/ft series to turn on the power (the POWER LED lights).
- Did you install the CPU/IO module properly?
 - Check if the CPU/IO module is properly installed in the server. Secure the CPU/IO module with screw located on the module removable handle.

POST fails to complete:

- Is the DIMM installed?
 - At least one DIMM is required for operation.
- Is the memory size large?
 - The memory check may take a time if the memory size is large. Wait for a while.
- Did you perform any keyboard or mouse operation immediately after you started the server?
 - If you perform any keyboard or mouse operation immediately after start-up, POST may accidentally detect a keyboard controller error and stops proceeding. In such a case, restart the server once again. Do not perform any keyboard or mouse operation until the BIOS start-up message appears when you restart the server.
- Does the server have appropriate memory boards or PCI card?
 - Operation of the server with unauthorized devices is not guaranteed.

Server reboots while running the SAS Configuration utility:

- Have you modified the Setup settings?
 - From [Server] - [Monitoring Configuration] - [Option ROM Scan Monitoring] of Setup, select “Disabled.” If [Option ROM Scan Monitoring] is enabled, the system may reboot while using the SAS Configuration utility. Change back the setting after you finish using the utility.

Fail to access to external devices:

- Are cables properly connected?
 - Make sure that the interface cables and power cord are properly connected. Also make sure that the cables are connected in the correct order.
- Is that device compliant with NEC Express5800/ft series?
 - Operation of the server with unauthorized devices is not guaranteed.
- Is the power-on order correct?
 - When the server has any external devices connected, power on the external devices first, then the server.
- Did you install drivers for connected optional devices?
 - Some optional devices require specific device drivers. Refer to the manual that comes with the device to install its driver.
- Is SCSI controller (including options) configuration correct?
 - If the sever has an optional SCSI controller board and SCSI devices are hooked up to the server, make correct settings by the SCSI controller board’s SCSI BIOS utility. For details, see manuals included with the SCSI controller board.

CPUs not in Duplex mode:

- Check if the memory configuration is correct.
- Check if third-party CPUs or memory (DIMM) are used.

Disks not in Duplex mode:

- Unless you perform mirroring (including reconfiguration after failed disks are replaced) in correct order, the mirror may not be (re)configured. Check if the steps were correct.

RAID configuration is not automatically resynchronized even though the failed hard disk is replaced:

- Generally, when you replace a failed hard disk, RAID configuration is automatically resynchronized.

If RAID configuration is not resynchronized automatically, you can resynchronize it manually.

(See Chapter 3 “Replacing a hard disk drive” for details.)

Occasionally, the replaced disk may not be recognized.

If this happens, follow the steps below.

- 1) Remove the disk, wait for approximately 15 seconds and then insert the disk again.
- 2) If the disk is not recognized even after the operation above, stop the PCI module in which the unrecognized disk is installed by using ft server utility, then restart.

See Chapter 3 “Evaluate Startup and Stop of PCI Modules” for information on starting/stopping PCI module.

The keyboard or mouse fails to operate:

- Is the cable properly connected?
 - Make sure that the cable is connected to the correct connector on the rear of the server.
- Are the keyboard and mouse are compliant with NEC Express5800/ft series?
 - Operation of the server with unauthorized devices is not guaranteed.
- Does the server have drivers installed?
 - Refer to the manual that comes with your OS to check that the keyboard and mouse drivers are installed. (These drivers are installed along with the OS.) Some OS allow you to change the keyboard and mouse settings. Refer to manual that comes with your OS to check that the keyboard and mouse settings are correct.

Screen freezes, keyboard and mouse don't work:

- If the amount of memory is large, it takes time to copy the memory in dual mode and the system stops working temporarily during the copying, but it is not system trouble.

Fail to access (read or write) to the floppy disk:

- Does the floppy disk drive contain a floppy disk?
 - Insert a floppy disk into the floppy disk drive until it clicks.
- Is the floppy disk write-protected?
 - Place the write-protect switch on the floppy disk to the "Write-enabled" position.
- Is the floppy disk formatted?
 - Use a formatted floppy disk or format the floppy disk in the floppy disk drive. Refer to the manual that comes with the OS for formatting a floppy disk.

Fail to access to the CD/DVD-ROM:

- Is the CD/DVD-ROM properly set in the CD/DVD-ROM drive tray?
 - The tray is provided with a holder to secure the CD/DVD-ROM. Make sure that the CD/DVD-ROM is placed properly in the holder.
- Is the CD/DVD-ROM applicable to the server?
 - The CD/DVD-ROM for Macintosh is not available for use.

Fail to access the hard disk:

- Is the hard disk applicable to the server?
 - Operation of any device that is not authorized by NEC is not guaranteed.
- Is the hard disk properly installed?
 - Make sure to lock the hard disk with the lever on its handle. The hard disk is not connected to the internal connector when it is not completely installed (see Chapter 8). When the hard disk is properly installed, the drive power LED for the hard disk is lit while the server is powered.

Fail to start the OS:

- Is a floppy disk in the floppy disk drive?
 - Take out the floppy disk and restart the server.
- Is the NEC EXPRESSBUILDER DVD (or the other bootable DVD/CD-ROM) in the optical disk drive?
 - Take out the DVD (or the other bootable DVD/CD-ROM) and restart the server.
- Is the OS damaged?
 - Use the recovery process of the OS to attempt to recover the damaged OS.

OS behavior is unstable:

- Aren't you making access to directory or file in /dev, /proc or /sys?
 - The NEC Express5800/ft series frequently saves and updates information related to system operation and management in the following directories. Because accessing any of these directories by a command or other means may impact fault tolerant functions and make behavior of the system unstable, do not access them.

/dev/mem
/proc/kcore
/proc/bus
/proc/ft
/proc/ide
/sys

The server is not found on the network:

- Is the LAN cable connected?
 - Make sure to connect the LAN cable to the network port on the rear of the server. Also make sure to use the LAN cable that conforms to the network interface standard.
- Have the protocol and service already configured?
 - Install the distinctive network driver for the server. Make sure that the protocol, such as TCP/IP, and services are properly specified.

Is the transfer speed correct?

→ The built-in LAN controller mounted as standard on this server can be used in network with the transfer speed of 1000Mbps, 100Mbps or 10Mbps. You can change the transfer speed or configure the setting from OS. However, do not use the “Auto Detect” function. Fix the setting of the transfer rate to the same with that of the connected hub. Also, check if the duplex mode is the same with that of the connected hub.

The transfer speed can be configured by editing /etc/modprobe.d/ft-network.conf. The configuration is effective internal network adapters N8804-002 and N8804-005. When you configure eth100200, for example, add the following description to /etc/modprobe.d/ft-network.conf.

```
option eth100200 Speed=1000 Duplex=2
```

Select one of the following three from the speed value.

```
1000 = 1000Mbps
100 = 100Mbps
10 = 10Mbps
```

Select one of the following two for the duplex value.

```
1 = Half duplex
2 = Full duplex
```

Machine repeats rebooting at startup:

Is the value of [OS Boot Monitoring] in the BIOS setting appropriate?

→ Please disable the setting of [OS Boot Monitoring].

(For details, please refer to page 4-8 “Step3:Disable OS Boot Monitoring Function” of User’sGuide(Setup) on separate volume)

- When shifting to the maintenance mode while the system is starting.

*The following message are displayed on the screen.

[Give root password for maintenance (or type Control-D to continue)]

- When neither the demons nor the drivers start correctly due to the trouble etc.

* NEC will recommend changing ten minutes

of the Default-setting into appropriate time with BIOS setup menu,

in case of the device configuration with

mounted memory of large capacity and hard disk.

Disk access LEDs on the disks are off:

→ The LEDs may seem to be off when an excessive amount of access causes the frequent blinking. Check if the LEDs are blinking green when the access is reduced.

Memory dump (debug information) cannot be collected when a failure occurs:

- Make sure that the partition (e.g. /var/crash) to which memory dump (debug information) is stored has enough free disk space.

A CPU/IO module cannot be integrated:

- When reinstallation is done due to a failure in a component, the reinstallation may stop with the following message recorded in a log file. If this occurs, MTBF of the component does not reach the threshold and the reinstallation cannot be performed as it is determined that repair is needed. Typically, device replacement is required. Contact your maintenance service engineer. Should any reason requires, you can forcefully reinstall the currently used device through consultation with the maintenance service engineer.

- x is now STATE_BROKEN / REASON_BELOW_MTBF
(x is a device number)

Screen under changing (distorted display) can be seen when screen resolution is changed:

If screen resolution is changed while the entire system is under high load, screen under changing (distorted display) may be seen.
This is because screen update is taking time to complete due to high load in the system. This is not because an error is occurring.
The screen will return to normal if you wait awhile.

Unable to recognize the server from a managing PC:

- Did you configure [Initialize Remote Management Card]?
 - Start the server-accessory EXPRESSBUILDER, then go to [Tools] - [Initialize Remote Management Card] to write each server information in order to initialize the card.

- Does your management PC contain Java2 RuntimeEnvironment, Standard Edition 1.4.2_04 or later?

→Java2 RuntimeEnvironment, Standard Edition 1.4.2_04 or later is required. Use the following procedure to install.

Start Windows on a management PC that you want to install the Java, then insert the EXPRESSBUILDER DVD into the DVD-ROM drive. Windows automatically launches the Autorun menu.

Click [Software Setup] - [DianaScope]. Run the JRE installer in the DianaScope installation menu.

If you would like to install the latest Java Runtime, go to the following website to download:

<http://java.sun.com/j2se/>

However, as JRE6 and later are not supported, they cannot be used.

- Do you connect LAN cable appropriately?

→Check if LAN cable is connected appropriately. The server sensors work properly only when the cable is connected properly. Make sure the cable isn't mistakenly connected to the server's LAN connector or to the serial port connector.

- Check if IP address is duplicated?

→IP address for the management LAN port is configured as 192.168.1.1 at the factory default setting. Change the IP address if this one is already used on the network, as this one isn't recognized appropriately.

- Did you set NEC ESMPRO Agent to monitor the server?

→Change the ESMPRO setting. Start NEC ESMPRO Agent in the Windows control panel, then go to [Express5800 Server] - [Monitor] from [System] tab, then click the check box. ([Unmonitored] is selected by default) After changing the setting, the server monitoring starts automatically. You do not have to reboot the server, but you need to restructure the tree if you still cannot monitor the server.

- Is network connection restricted by the firewall or the gateway?

→ Network connection may be restricted by a firewall setting. See if you can solve the problem by connecting the server and a client PC directly with a cross cable. Refer to Chapter 4 [Remote Management Function] - [BMC Configuration] - [Network Configuration], then check the port of the Remote Management Card and set the firewall or the gateway.

Server console screen does not appear on the web Remote KVM console screen:

- Did you set the server's screen resolution properly?

→When you display the server screen by using the remote KVM in the Remote Management function, set the screen resolution 1024 x 768 and the refresh rate should be less than 75Hz.

Forgot login name/password for the Remote Management Function on the web browser:

→ Refer to Chapter 4 on BMC configuration jumper. By changing the jumper position, the BMC configuration including the password returns to the factory default setting.

IMPORTANT:

After the operation, the BMC configuration for connecting to the DianaScope and to the server will be lost. If you are already using the DianaScope, save the configuration on FloppyDisk before this operation, then configure again. You can change/save the BMC configuration on the system management function of DianaScope or EXPRESSBUILDER.

Wake On LAN does not function:

- Is the AC power supplied to both AC cables?
 - If the AC power supplied to only one of the AC cabled, Wake On LAN may become unavailable. Supply the AC power supply to both of the AC cables, and press the power switch to start the system.
- Is the network adapter configured on OS?
 - On the OS, go to [Start] - [Management Tool] - [Computer management] and select the Device Manager. Double click [Stratus emb-82576 2-Port Gigabit Adapter #n] under the network adapter, then select the following option from [Power Management] tab:

Wake on Magic Packet from power off state

TIPS:

Wake On Magic packet is unavailable even it is checked.

- Is Hub/Client fixed as 1000M?
 - Check the following configurations:
 - Set the Hub as “Auto-Negotioation.”
 - Set the Client as “Auto-negotiate best speed.”

IMPORTANT:

For both Hub/Client, you cannot function Wake On LAN from standby with the 1000M fixed configuration.

- Do you happen to be sending Magic Packet to only one of the duplexed LAN?
 - If you use Wake On LAN under duplexed LAN, you need to send Magic Packet to all of the duplexed LAN pair(s).

When OS starts, the error message is displayed.

- When OS starts, the following error message is displayed. But it is not problem in the system.
 - ACPI Error (evxfevnt-0189): Could not enable.
 - RealTimeClock event[20060707]
 - PCI: Cannot allocate resource region 0 of device 0000:01:00.0
 - PCI: Cannot allocate resource region 0 of device 0000:01:00.1
 - PCI: Failed to allocate mem resource #0:1000@a4000000 for 0000:01:00.0

Problems with NEC EXPRESSBUILDER

When the server is not booted from the NEC EXPRESSBUILDER DVD, check the following:

- Did you set the NEC EXPRESSBUILDER DVD during POST and restart the server?
 - If you do not set the NEC EXPRESSBUILDER DVD during POST and restart the server, an error message will appear or the OS will boot.
- Is BIOS configuration correct?
 - The boot device order may be specified with the BIOS setup utility of the server. Use the BIOS setup utility to change the boot device order to boot the system from the optical disk drive first.
<Menu to check: [Boot]>
- If [Os installation] is selected at Boot selection screen, following message is displayed.

After this message appears, check the error and take the appropriate corrective action according to the error codes listed in the table below.

Message	Cause and Remedy
This EXPRESSBUILDER version was not designed for this computer. Insert the correct version and click [OK]. (When you click [OK], the computer reboots)	This EXPRESSBUILDER version was not designed for this server. Execute the NEC EXPRESSBUILDER on the compliant server.
EXPRESSBUILDER could not get the hardware parameters written in this motherboard. This version is not designed for this computer or the motherboard may be broken. (When you click [OK], the computer reboots)	This message is shown when such as NEC EXPRESSBUILDER could not find system-specific information because of motherboard exchanged.
The hardware parameters written in this motherboard are incorrect. This version is not designed for this computer or the motherboard may be broken. (When this error occurs just after changing the motherboard, configure the hardware information properly on the [Maintenance Utility])	

Problems with Autorun Menu

Cannot read online document:

- Do you have Adobe Reader installed correctly in your system?
 - Some online documents are supplied with PDF format. To read the document of PDF format, Adobe Reader is required in your system.
- Is the operating system Windows XP SP 2?
 - With Windows XP SP2, the following information may appear in browser.

“To help protect your security, Internet Explorer has restricted this file from showing active content that could access your computer. Click here for options...”

 1. Click the Information Bar.
The shortcut menu appears.
 2. Click [Allow blocked content].
The security alert dialog box appears.
 3. Click [Yes] on dialog box.

The menu fails to appear:

- Is your system Windows XP or later, or Windows 2003 or later?
 - The Windows Autorun Menu is supported by Windows XP/Windows 2003 or later.
 - If your system runs on Windows Autorun Menu on Windows 2000 system, you need to setup IE6.0 before using Windows Autorun Menu.
 - The menu is not available for Windows 2008 server core environment.
- Is **Shift** key being pressed?
 - Setting the DVD/CD-ROM with Shift pressed down cancels the Autorun Menu.
- Is the system in the proper state?
 - The menu may not appear depending on the system registry setting or the timing to set the DVD/CD-ROM. In such a case, eject the disk from the disk drive once and insert it again.

Some menu items are grayed-out:

- Is your computer environment correct?
 - The menu items are grayed-out when the logon user does not have the authority of the Administrator or the system does not meet the requirements to install the application. Login with the user having the proper authority on the proper system, and try again.

Problems with NEC ESMPRO

NEC ESMPRO Manager

→ See Chapter 5. See also online document in NEC EXPRESSBUILDER DVD for troubleshooting and other supplementary information.

NEC ESMPRO Agent

→ See Chapter 5.

COLLECTING TROUBLE LOGS

In the event of trouble, you can get information in the procedures described below:

IMPORTANT:

- You can perform the procedures described below only when you are asked by your maintenance personnel to get trouble logs.
 - When the system restarts after the trouble, it may show a message that there is a shortage of virtual memory. However, continue the system startup. If you reset and restart the system, you cannot get correct information.
-

Collection of System Information

IMPORTANT:

- If you collect a system information with the below command, verify that the collect-target's disk partition has enough free space.
 - This must be operated as a root user.
-

When you collect system information in the NEC Express5800/ft series, execute the below command:

```
#/opt/ft/sbin/buggrabber.pl
```

The collected data will be stored in the following created directory.

```
/home/BugPool/
```

TIPS:

If you change the collect target, add the below option to the above command and execute.

```
--bugpool=<relative/absolute path to the targeted directory>
```

COLLECTING THE MEMORY DUMP

If a failure occurs, the memory data should be dumped to acquire the required information. If you stored the dump data in a DAT, label it so as to indicate the software (e.g. NTBackup) you used for storing it. You may save the diagnosis data to a desired destination.

IMPORTANT:

- Consult with your sales agent before dumping the memory. Executing memory dumping while the server is in the normal operation may affect the system operation.
 - Restarting the system due to an error may display a message indicating insufficient virtual memory. Ignore this message and proceed. Restarting the system again may result in dumping improper data.
 - Press the DUMP switch on the primary CPU/IO module, whose POWER LED has been blinking, for four to eight seconds. Use something sharp, such as curved clips to press the DUMP switch on CPU/IO module 1.
-

Preparing to collect Memory Dump

Memory dumping with the DUMP switch may disable the server to restart. In such a case, it is required to force the server to shut down.

Saving Dump Files

Press the DUMP (NMI) switch on the primary CPU/IO module to save the dump file when an error occurs. Insert something sharp-pointed like a pen into the switch hole to press the DUMP switch.

Pressing the DUMP switch saves the dump file in the specified directory. (Memory dumping may not be available when the CPU stalls.)

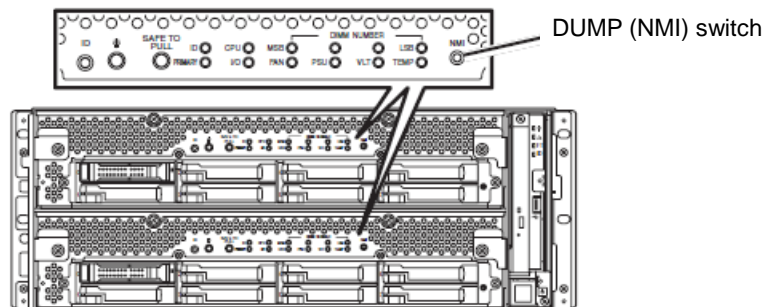

IMPORTANT: Do not use a toothpick or plastic stick that is easy to break.

Chapter 8

System Upgrade







This chapter describes procedures to add options and replace failed components.





IMPORTANT:

- Optional devices described in this chapter should not be installed or removed by the user. NEC does not assume any liability for damage to optional devices or the server or malfunctions of the server resulted from installation by the user.
 - Be sure to use only optional devices and cables designated by NEC. Repair of the server due to malfunctions, failures, or damage resulted from installing undesignated devices or cables will be charged.
-

SAFETY PRECAUTIONS

Observe the following notes to install or remove optional devices safely and properly.

 WARNING	
     	<p>Observe the following instructions to use the server safely. There are risks of death or serious personal injury. See “PRECAUTIONS FOR SAFETY” in Chapter 1 for details.</p> <ul style="list-style-type: none">• Do not disassemble, repair, or alter the server.• Do not look into the DVD-ROM drive.• Do not remove the lithium battery.• Disconnect the power plug before working with the server.

 CAUTION	
   	<p>Observe the following instructions to use the server safely. There are risks of fire, personal injury, or property damage. See “PRECAUTIONS FOR SAFETY” in Chapter 1 for details.</p> <ul style="list-style-type: none">• Do not install or remove components by a single person.• Do not install the server leaving the cover removed.• Make sure to complete component installation.• Do not pinch your finger(s).• High temperature

ANTI-STATIC MEASURES

The server contains electronic components sensitive to static electricity. Avoid failures caused by static electricity when installing or removing any optional devices.

- Wear wrist straps (arm belts or anti-static gloves).

- Wear wrist straps on your wrists. If no wrist strap is available, touch an unpainted metal part of the cabinet before touching a component to discharge static electricity from your body.

- Touch the metal part regularly when working with components to discharge static electricity.

- Select a suitable workspace.

- Work with the server on the anti-static or concrete floor.
 - When you work with the server on a carpet where static electricity is likely to be generated, make sure take anti-static measures beforehand.

- Use a worktable.

- Place the server on an anti-static mat to work with it.

- Clothes

- Do not wear a wool or synthetic cloth to work with the server.
 - Wear anti-static shoes to work with the server.
 - Take off any metal accessories you wear (ring, bracelet, or wristwatch) before working with the server.

- Handling of components

- Keep any component in an anti-static bag until you actually install it to the server.
 - Hold a component by its edge to avoid touching any terminals or parts.
 - To store or carry any component, place it in an anti-static bag.

PRE-UPGRADE VERIFICATION

If you add on optional devices onto this equipment, some devices require specific ft server software version (s).

If the optional asks for specific version number (s), refer to the following procedure before adding on the devices.

- 1.** Confirm the required ft server control software's version, Refer to the sever-accessory User's Guide, check the NEC website, or contact your sales representative.
- 2.** Verify the version of the ft control software on your system.
- 3.** After confirming it as the available version, add the device onto the server.

For more information on how to verify the working ft server utility's, refer to the separate User's Guide (setup) "Confirming the ft Server Control Software Version" (page 5-13).

PREPARING YOUR SYSTEM FOR UPGRADE

Note the following, when installing or replacing devices, to improve the performance of NEC Express5800/ft series.

- With the NEC Express5800/ft series, devices can be replaced during the continuous operation. Take extreme care for electric shock and damage to the component due to short-circuit.
- Optional devices cannot be installed or removed during continuous operation. After shutting down OS, check that the server is powered off, disconnect all power cords and interface cables from the server before installing or removing the optional devices.
- To remove the CPU/IO module during the continuous operation, disable the intended module (place the module off-line) by using the ftServer Utility of the NEC ESMPRO Agent or the NEC ESMPRO Manager from the management PC on the network. After a new module is installed to the server, enable the module using the ftServer Utility or the NEC ESMPRO Manager.

TIPS:

The system is defaulted to automatically boot the module, once installed. For more information, see Chapter 5.

- Make sure to provide the same hardware configuration on both CPU/IO modules (except SCSI board).
- Use the same slots and sockets on both groups.
- Do not install those devices having different specifications, performance, or features.
- Before removing the set screws from the CPU/IO modules, place the desired module off-line using the ftServer Utility or the NEC ESMPRO Manager.

2.5-INCH HARD DISK DRIVE

The 2.5-inch hard disk drive bays in front of the server can mount up to 16 hard disk drives with the 2.5 inch width exclusive trays.

IMPORTANT:

Do not use any hard disks that are not authorized by NEC. Installing a third-party hard disk may cause a failure of the server as well as the hard disk. Purchase hard disks of the same model in pair. Contact your sales agent for hard disk drives optimum for your server.

The operation is executed on the created mirror volume with installed hard disk drive pairs such as slot 0 on CPU/IO module 0/1, slot 1 on CPU/IO module 0/1, slot 2 on CPU/IO module 0/1. (The OS is installed on the mirror volumes that consist of the hard disks in the slot 0.)

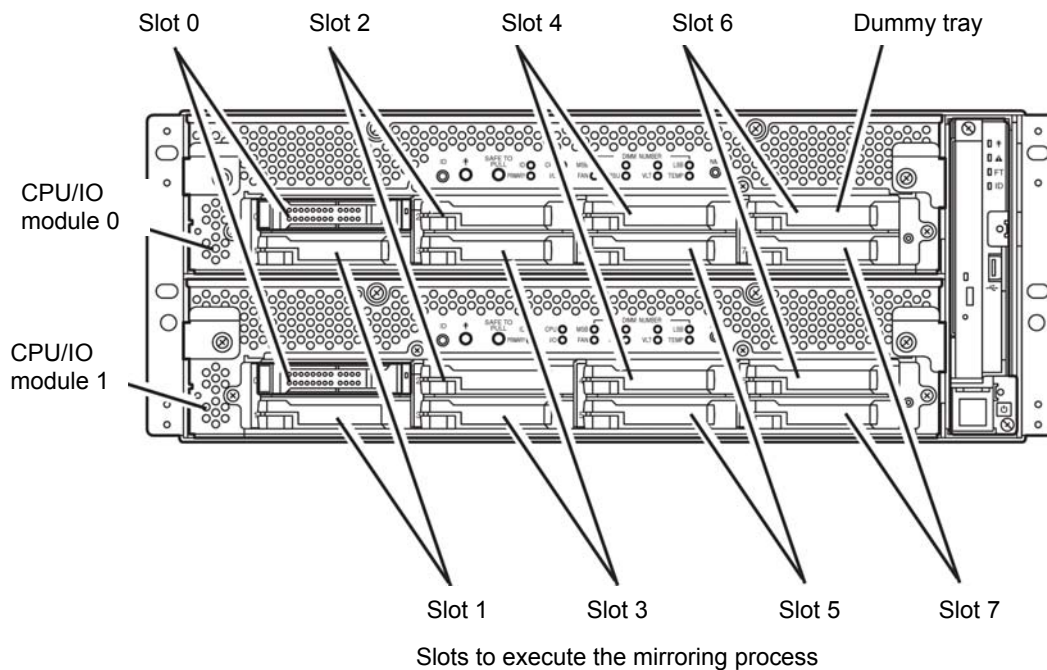

Empty slots in the 2.5-inch hard disk drive bay contain dummy trays. The dummy trays are inserted to improve the cooling effect within the device. Always insert the dummy trays in the slots with no hard disks drive installed.

Installing 2.5-inch Hard Disk Drive

Follow the procedure below to install the hard disks. Install the hard disks from a smaller slot number to large number on CPU/IO module 0/1, from slot 0 to slot through slot 7.

IMPORTANT:

- Refer to “ANTI-STATIC MEASURES” and “PREPARING YOUR SYSTEM FOR UPGRADE” before starting installing or removing options.
 - You must mount two HDDs that form dual disk configuration before starting the OS.
1. Shut down the OS. The system turns off automatically.
 2. Remove the front bezel.
 3. Identify the slot to which you want to install a hard disk drive.
 4. If a dummy tray is inserted in a slot you want to install the hard disk drive, remove the dummy tray.

IMPORTANT:

Keep and store the dummy tray with care.

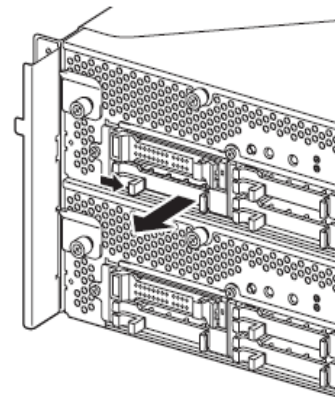

5. Unlock the hard disk drive.

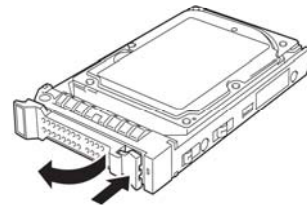

6. Firmly hold the handle of the hard disk drive to install and insert the drive into the slot.

TIPS:

- Insert the disk until the lever hook touches the server frame.
 - Check the direction of the lever. Insert the hard disk with the lever unlocked.
-

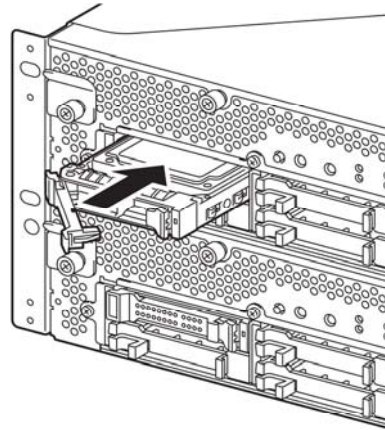

7. Slowly close the lever. When the lever is locked, you will hear a click sound.

IMPORTANT:

Be careful not to pinch your finger(s) between the lever and handle.

TIPS:

Check the hook of the lever is engaged with the frame.

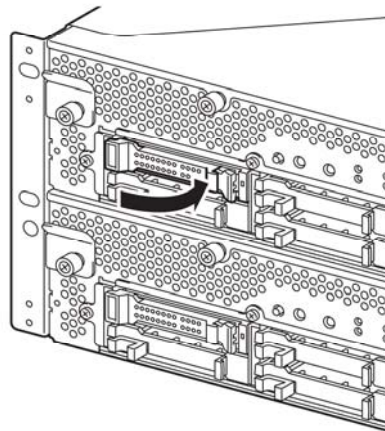

8. Press the POWER switch to power on.
9. Install the front bezel.
10. Refer to “Step 8: Set Dual Disk Configuration” in Chapter 4 in the User’s Guide (Setup) to set the dual disk configuration.

Removing 2.5-inch Hard Disk Drive

Follow the procedure below to remove the hard disk drive.

IMPORTANT:

Make sure to read “ANTI-STATIC MEASURES” and “PREPARING YOUR SYSTEM FOR UPGRADE” before you take the following procedures.

1. Shut down the OS.
The system turns off automatically.
2. Remove the front bezel.
3. Push the lever of the hard disk to unlock the handle.

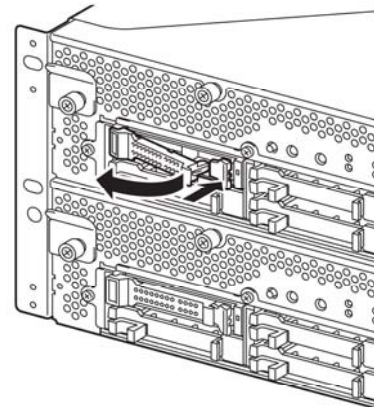

4. Hold the handle and hard disk to pull them off.
5. Install the dummy tray in an empty tray according to procedures described in “Installing 2.5-inch Hard Disk Drive.”

Ensure to install the dummy slot in the empty slot to improve the cooling effect within the device.

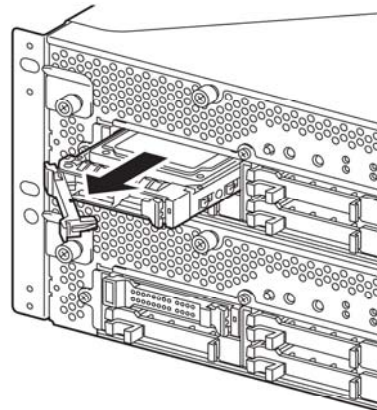

Replacing 2.5-inch Hard Disk Drive

Follow the procedure below to remove the failed hard disk drive. The hard disk drive is replaced with new device with the server powered on.

IMPORTANT:

Make sure to read “ANTI-STATIC MEASURES” and “PREPARING YOUR SYSTEM FOR UPGRADE.” You can replace disks during continuous operation.

Replacing the Hard Disk Drive

1. Locate the failed hard disk.

When a hard disk fails, the DISK ACCESS LED on the hard disk drive’s handle illuminates amber.

2. Remove the failed hard disk referring to “Replacing Failed Hard Disk Drives” on page 3-21 and “Removing 2.5-inch Hard Disk Drive” on page 8-9.

Shutdown of Windows Server 2003 is unnecessary.

3. Refer to the steps in “Installing 2.5-inch Hard Disk Drive” to install a new hard disk.

CHECK:

- The hard disk to be installed for replacement must have the same specifications as its mirroring hard disk.
 - Use unsigned hard disk drive for replacement. To use the signed disk, it is necessary to recover the duplex configuration by referring to “Disk Operation” in chapter 3 after formatting the disk physically.
 - As to physical format, refer to “SAS BIOS - SAS Configuration Utility -s” in Chapter 4, “System Configuration” in the separate volume of the User’s Guide, and perform Format Disk with Disk Utilities.
 - Before performing physical formatting, change [Option ROM Scan Monitoring] to [Disabled] on [Server] - [Monitoring Configuration] on the BIOS setup utility.
 - Refer to the separate volume of the User’s Guide User’s Guide “SYSTEM BIOS - SETUP -” in “Chapter 4 System Configuration” for configuration.
-

4. Restore the redundant configuration (see Chapter 3).

CPU/IO MODULE

To replace a CPU (processor, DIMM (memory), PCI card, you need to remove the CPU/IO module.

IMPORTANT:

- Ask your sales agent to replace the CPU/IO module and components of the CPU/IO module.
 - Make sure to read “ANTI-STATIC MEASURES” and “PREPARING YOUR SYSTEM FOR UPGRADE.”
 - To install or remove CPU or DIMM, first power off the server before removing the CPU/IO module.
 - Removing the module being operating may cause unexpected trouble. Use the management software (e.g., ftServer Utility or NEC ESMPRO Manager) to identify the module to be removed so that the module is removed when it is stopped, without fail. Then remove the relevant module after verifying the Status LED on the CPU/IO module. See Chapter 2 “LEDs” for details of the Status LED.
-

Precautions

When replacing both CPU/IO modules, replace one module and wait until dual configuration is established to replace the other module. If you replace the both modules simultaneously, establishing dual CPU/IO module configuration can result in interruption of the whole system.

Removing CPU/IO Module

Follow the procedure below to remove the CPU/IO module.

1. Stop the CPU/IO module you want to remove.

To this end, use the ftServer Utility of the NEC ESMPRO Agent installed to your server or the DataViewer of the NEC ESMPRO Manager.

For the detailed procedure, see “NEC ESMPRO Agent and Manager” – “Maintenance of NEC Express5800/ft series” in Chapter 5.

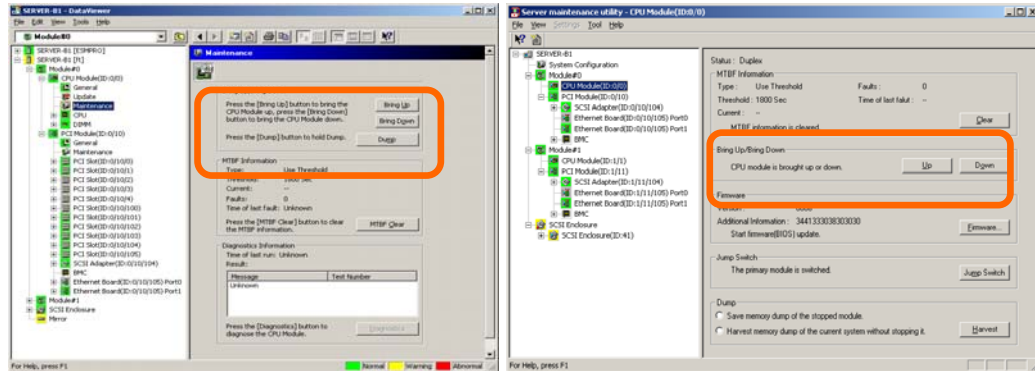

NEC ESMPRO Manager

Select [ft] - [CPU Module] - [CPU Module (to be removed)] - [Maintenance] - [Bring Up/Bring Down] - [Bring Down].

ftServer Utility

Select [FTServer] - [CPU Module] - [CPU Module (to be removed)] - [Bring Up/Bring Down] - [Down].

Repeat the operation mentioned above for the IO module (PCI module) and confirm that the status of the CPU/IO module and the IO module (PCI module) are “Removed.”

TIPS:

When removing CPU/IO modules 0, select [Bring Down] for CPU module (ID:0) and PCI module (ID:10)

2. Remove the front bezel

3. Disconnect the power cable of a removing module.
The stopper will return to the vertical position when you disconnect the cable.

CHECK:

Check whether the stopper drops down after disconnecting the power cable. If you disconnect the cable and the stopper does not go back to this position, you cannot pull out the CPU/IO module in the next step.

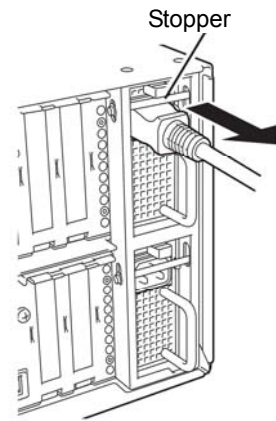

4. Loosen the screws securing the CPU/IO module handle to press down the handle.

IMPORTANT:

Before you pull out a CPU/IO module, check the rear of the server to make sure cables for connection with peripheral equipment or network are disconnected. If any cables are connected, keep a record of where the cables are connected and disconnect all cables connected to the module you are to pull out.

TIPS:

If you cannot disconnect the LAN cable easily, disconnect while pressing the latch with a slotted screwdriver.

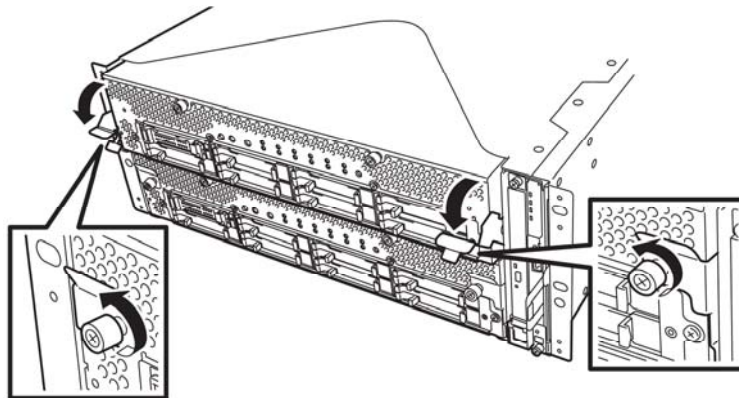

5. Hold the black levers of the CPU/IO module and pull it off.
Pull it off until it is locked and stopped.

IMPORTANT:

- Do not hold part other than the handle to pull the module.
 - Handle the CPU/IO module carefully. Do not drop the module or bump it against parts in the device when you remove it.
-

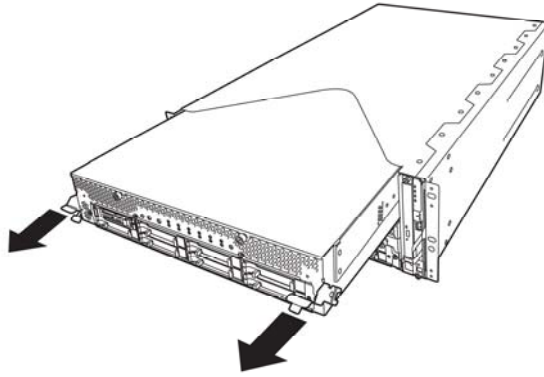

6. The CPU/IO module is locked on the way and cannot be pulled out. Lower the lock on the side of CPU/IO module and unlock it, and then pull it out.

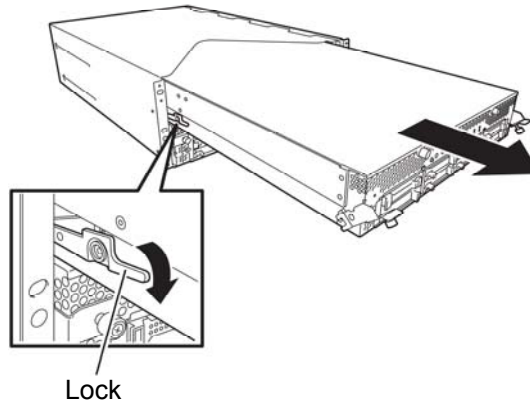

7. Pull out the CPU/IO module gently and carefully place it on a flat and sturdy table.
Avoid the dusty or humid place.

This allows you to access the devices in the CPU/IO module. For more information on how to handle these devices, see the associated sections.

Installing CPU/IO Module

Follow the procedure below to install the CPU/IO module:

IMPORTANT:

- Ensure to read “ANTI-STATIC MEASURES” and “PREPARING YOUR SYSTEM FOR UPGRADE.”
 - Insert the black lever slowly and fasten the screws tightly. Be careful not to cause a shock to the device at this time.
-

1. Firmly hold the CPU/IO module with both hands and insert it into the rack.

Hold the CPU/IO module in such a way that its back panel connector faces the back of the rack and engage the guides of the module and chassis, and insert it slowly.

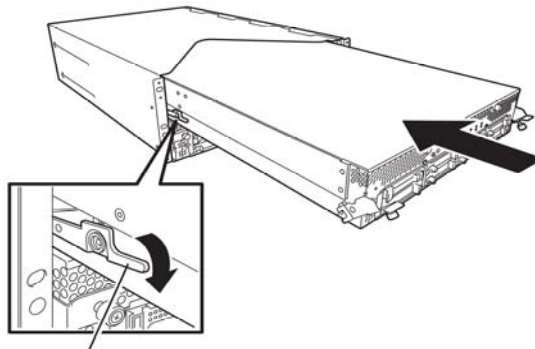

Lock

2. Push up the black levers placed on the left and right sides of the front of the CPU/IO module, and fasten them with screws.

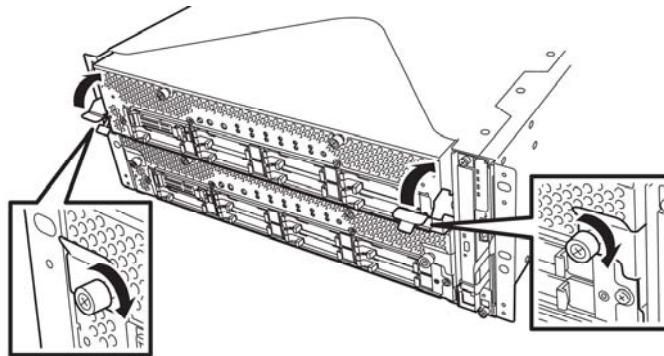

IMPORTANT:

- Secure the handle with the screws. If it is not secured by the screws, the operation of the CPU/IO module will be unstable.
 - In some system statuses or settings, auto start up or integration does not take place when the module is connected. In such a case, check the status by using the ftServer Utility or NEC ESMPRO Manager DataViewer, and then start up the CPU/IO modules.
-

3. Connect the cables for connecting the peripheral devices and network.
4. Hold the stopper with your hand and insert the cable of the installed module.
5. The installed CPU/IO module will be automatically started.

DIMM

The DIMM (dual inline memory module) is installed to the DIMM socket in the CPU/IO module on the NEC Express5800/ft series.

The CPU/IO module board has 12 sockets for DIMM.

TIPS:

- Up to 96GB(8GB x 12) memory can be additionally installed.
 - In the error messages and logs in POST NEC ESMPRO, or Off-line Maintenance Utility, the DIMM connector may be described as “group.” The number next to “group” corresponds to the slot number shown in the figure on the next page.
-

IMPORTANT:

- The DIMM is extremely sensitive to static electricity. Make sure to touch the metal frame of the server to discharge static electricity from your body before handling the DIMM. Do not touch the DIMM terminals or onboard parts with a bare hand or place the DIMM directly on the desk. For more information on static electricity, see “ANTI-STATIC MEASURES.”
 - Make sure to use the DIMM authorized by NEC. Installing a third-party DIMM may cause a failure of the DIMM as well as the server. Repair of the server due to failures or damage resulted from installing such a board will be charged.
 - Before adding or removing DIMMs, power off the server and detach the CPU/IO module.
 - Make sure to read “ANTI-STATIC MEASURES” and “PREPARING YOUR SYSTEM FOR UPGRADE” before installing/removing DIMM.
-

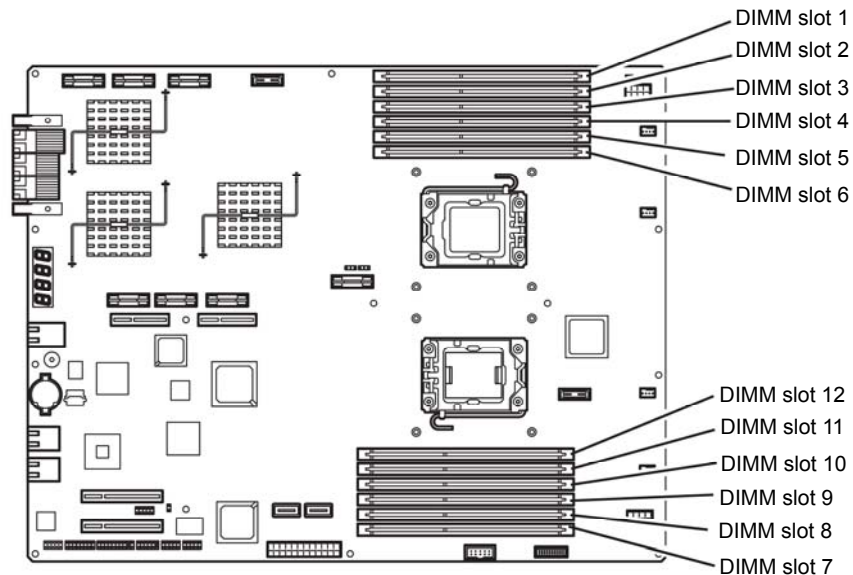

Motherboard of the CPU/IO module

Installing DIMM

Follow the procedure below to install the DIMM.

1. Shut down OS.
The server turns off automatically.
2. Disconnect the power cords from the outlets.
3. Remove the CPU/IO module referring to page 8-12.
4. Remove three screws (two on the front and one on the rear), and remove the top cover of the CPU/IO module.

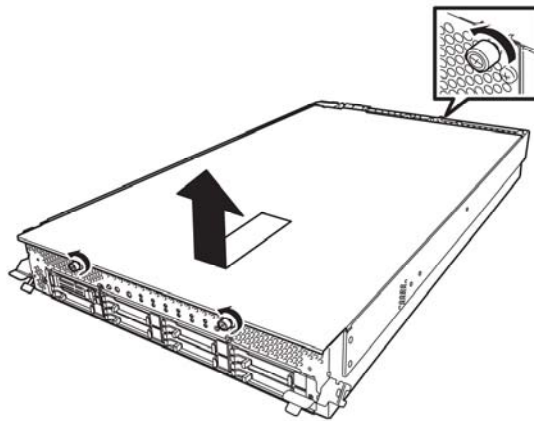

5. Remove the air duct.

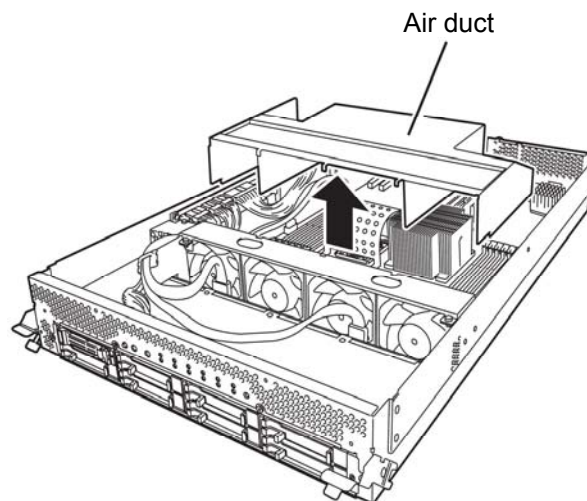

6. Check to be sure in which socket you are mounting the DIMM

7. Remove the dummy memory module by opening the levers on both sides of the DIMM slot.

IMPORTANT:

Keep and store the removed dummy memory module with care.

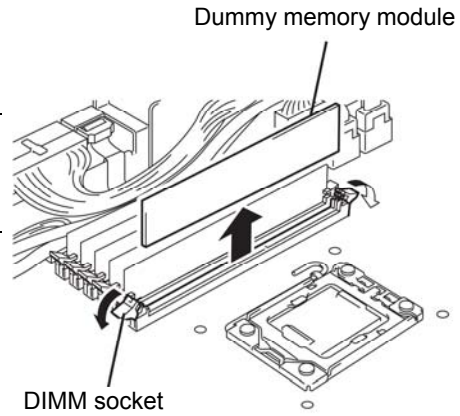

8. Insert a DIMM into the DIMM socket vertically.

TIPS:

Pay attention to the direction of the DIMM.
The terminal of the DIMM has a cutout to prevent misinsertion.

After the DIMM is completely inserted into the socket, the levers are automatically closed.

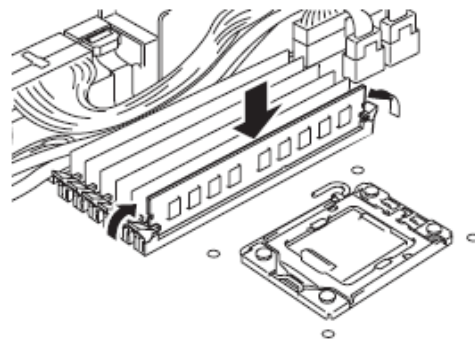

9. Attach the air duct
10. Place the top cover of the CPU/IO module and secure it with three screws.

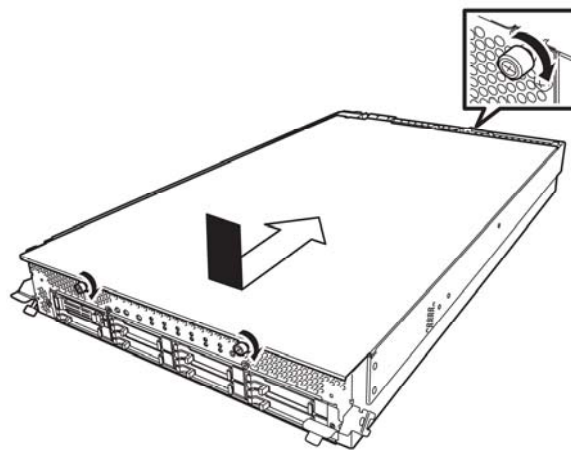

11. Refer to page 8-15 and install the CPU/IO module.
12. Connect the power cords.
13. Press the POWER switch to power on the server.
14. Verify that POST displays no error message.

If POST displays an error message, write it down and see the POST error message list on page 7-4.

15. After starting the OS, set the paging file size to at least the recommended value (1.5 times the installed memory size). (See “Size of the Partition to be Created” in Chapter 4 of the User’s Guide (Setup).)

Removing DIMM

Follow the procedure below to remove the DIMM.

IMPORTANT:

This server works only when there are at least two DIMMs installed.

1. Shutdown OS.
The system turns off automatically.
2. Disconnect the power cords from the outlets.
3. Remove the CPU/IO module referring to page 8-12.
4. Remove three screws (two on the front and one on the rear), and remove the top cover of the CPU/IO module

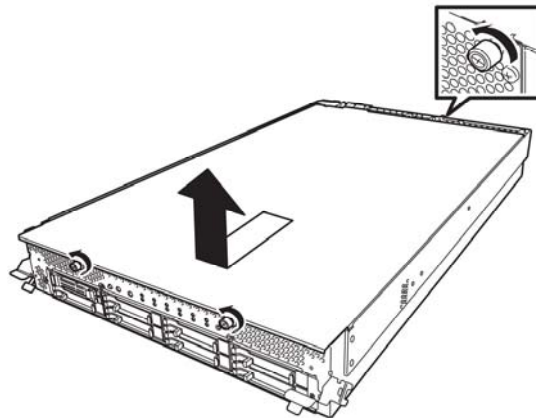

5. Remove the air duct.

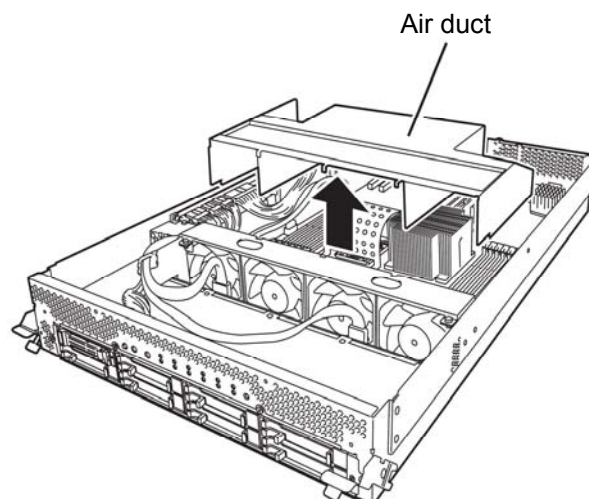

6. Open the levers attached on both sides of the socket of the DIMM to be removed. It will be unlocked and the DIMM can be removed.

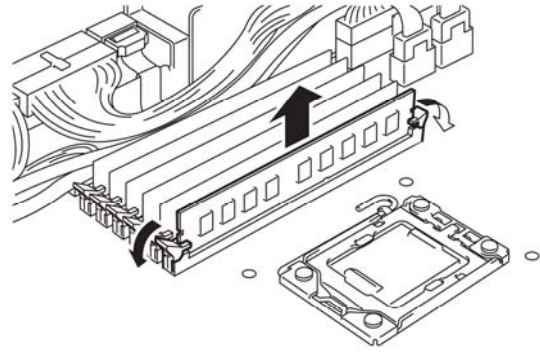

7. Attach the dummy memory module.
8. Attach the air duct.
9. Place the top cover of the CPU/IO module and secure it with three screws.

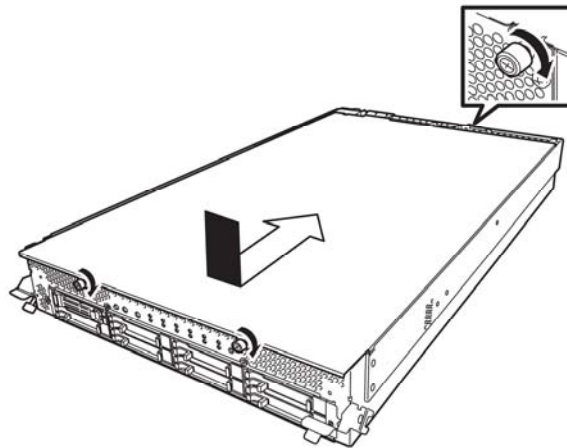

10. Refer to page 8-15 and install the CPU/IO module.
11. Connect the power cords.
12. Press the POWER switch to power on the server.
13. Verify that POST displays no error message.

If POST displays an error message, write it down and see the POST error message list on page 7-4.

Replacing DIMM

Follow the procedure below to replace a failed DIMM.

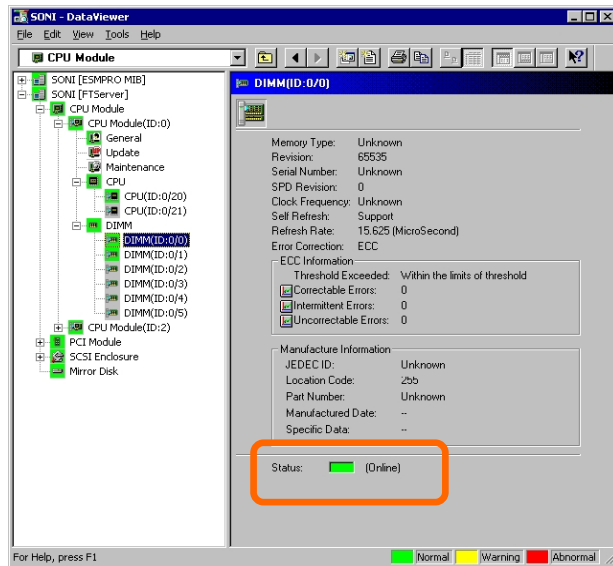

1. Identify the failed DIMM by referring to the memory slot error LED.
2. Remove the CPU/IO module referring to page 8-12.
3. Replace the DIMM.
4. Install the CPU/IO module referring to page 8-15.
5. Start up the CPU/IO module using NEC ESMPRO Manager or ftServer Utility.

PROCESSOR (CPU)

In addition to the standard CPU (Intel® Xeon™ Processor), you can operate the system by adding one CPU.

IMPORTANT:

- The CPU is extremely sensitive to static electricity. Make sure to touch the metal frame of the server to discharge static electricity from your body before handling the CPU. Do not touch the CPU terminals or onboard parts with a bare hand or place the CPU directly on a desk. Ensure to read “ANTI-STATIC MEASURES” for more information on static electricity.
 - Do not use the system before checking to see it works correctly.
 - Make sure to use the CPU specified by NEC. Installing a third-party CPU may cause a failure of the CPU as well as the server. Repairing the server due to failures or damage resulting from these products will be charged even if it is under guarantee.
 - Before adding or removing a CPU, power off the server and then remove the CPU/IO module.
-

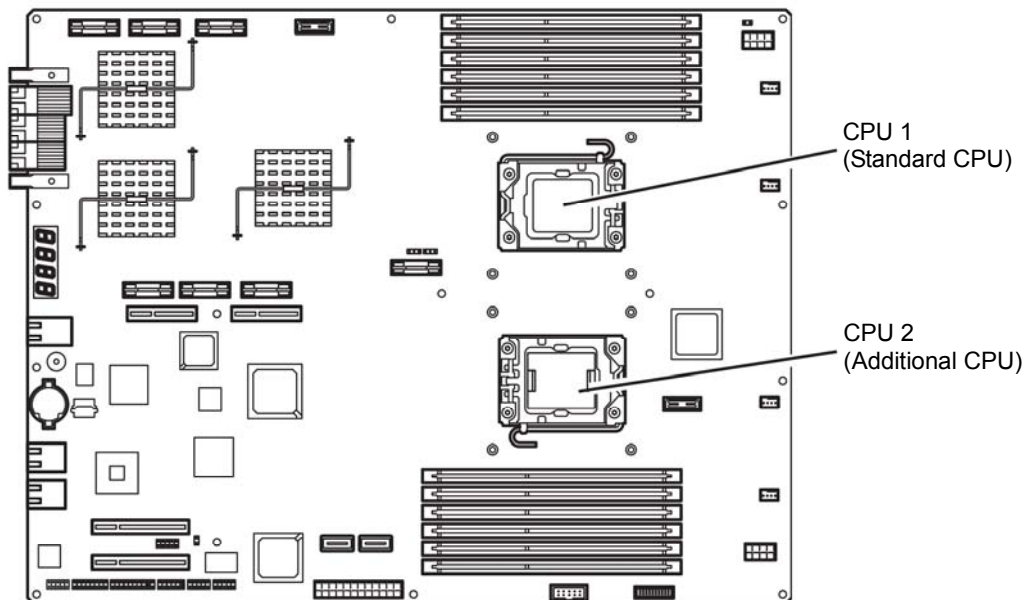

Installing CPU

Follow the steps below to install a CPU (model with air-cooling kit).

1. Shut down the OS.
The server is automatically powered off.
2. Unplug the power cords.
3. Remove the CPU/IO module referring to page 8-12.
4. Remove the cable connected to the air duct cover.
5. Verify the location of the CPU socket.
6. Remove four screws that secure the dummy heat sink.
Remove the dummy heat sink.

IMPORTANT:

Keep and store the removed dummy heat sink and four screws with care.

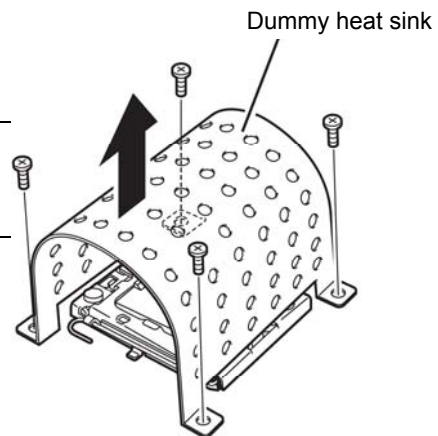

7. Lift the socket lever.

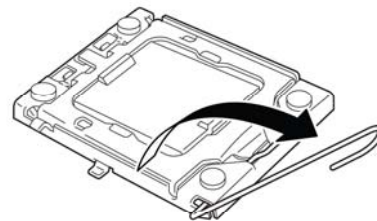

8. Lift the CPU socket holder.



9. Detach the socket cover on the CPU socket.

IMPORTANT:

Keep and store the removed socket folder with care.

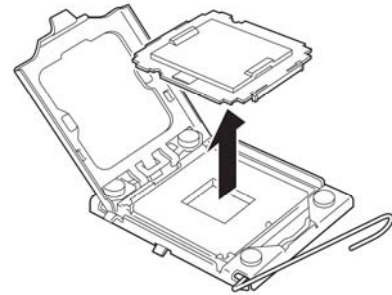

10. Place the CPU on the socket carefully.

TIPS:

Pay attention to the direction of the CPU. The CPU and socket have pin marks to prevent misinsertion. Check the pink marks of the CPU and the socket, and insert the CPU correctly.

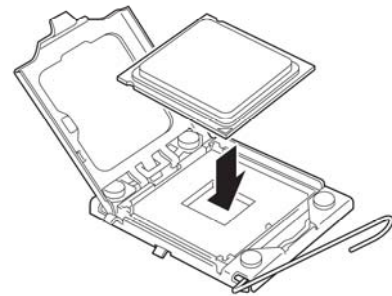

11. After pressing the CPU softly against the socket, place the CPU socket holder back to its original place.

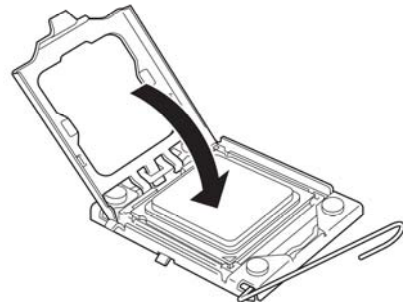

12. Return the socket lever back to its original place.



13. Place the heat sink on the CPU.

IMPORTANT:

Do not touch the cooling sheet that is attached on the back of the heat sink with your hand.

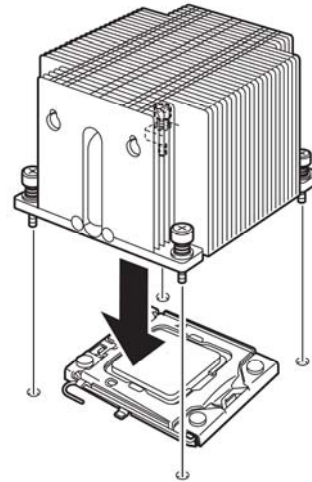

IMPORTANT:

If you install additional CPU, ensure that the fins of the additional CPU's heat sink are in the same direction as those of the standard CPU.

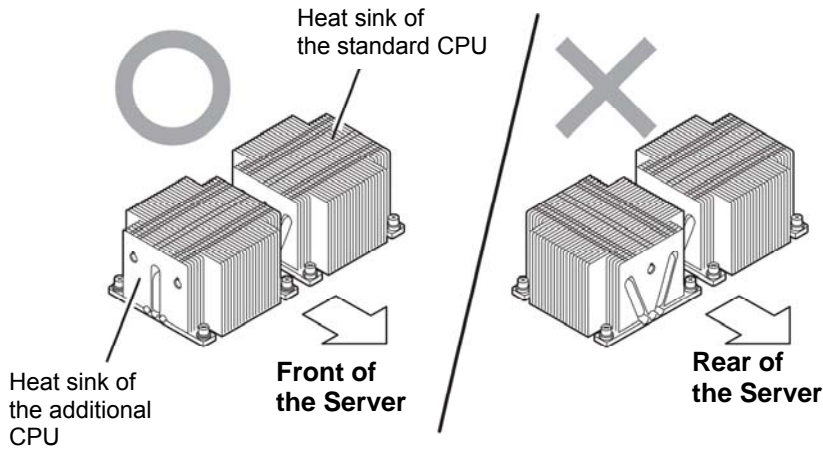

Heat sink of the additional CPU

Heat sink of the standard CPU

Front of the Server

Rear of the Server

14. Fasten the heat sink with four screws..

IMPORTANT:

Check that you have tentatively fastened the screws diagonally with the order on the right figure, and that they the heat sink is attached to the CPU socket in parallel level.
Then, tighten the screws with the order shown on the right.

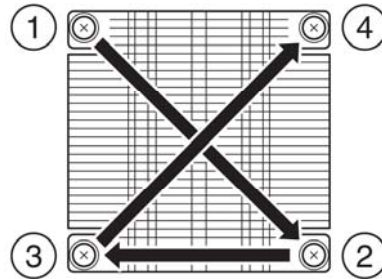

15. Install the air duct.

16. Refer to page 8-15 and install the CPU/IO module.

17. Connect the power cord.

18. Turn on the power by pressing the POWER switch.

19. Verify that POST displays no error message. If an error message is displayed, write it down and check it in the error message list on page 7-4.

Removing CPU

Removal of a heat sink and CPU is the reverse procedure of installation.

PCI BOARD

Either two or four PCI boards can be installed to the CPU/IO module.

IMPORTANT:

- The PCI board is extremely sensitive to static electricity. Make sure to touch the metal frame of the server to discharge static electricity from your body before handling the PCI board. Do not touch the PCI board terminals or onboard parts by a bare hand or place the PCI board directly on the desk. For more information on static electricity, see “ANTI-STATIC MEASURES” on page 8-3.
 - Make sure to read “ANTI-STATIC MEASURES” and “PREPARING YOUR SYSTEM FOR UPGRADE.”
-

Note the following to install or replace PCI board.

- Some PCI boards need to be duplexed. To make a dual PCI board configuration, install the same type of board (i.e., having the same specifications and performance) to the same slot for each group.

When a PCI board is installed to one group, another identical PCI board should be installed to the same slot in another group. This rule is applied to the case of removal.

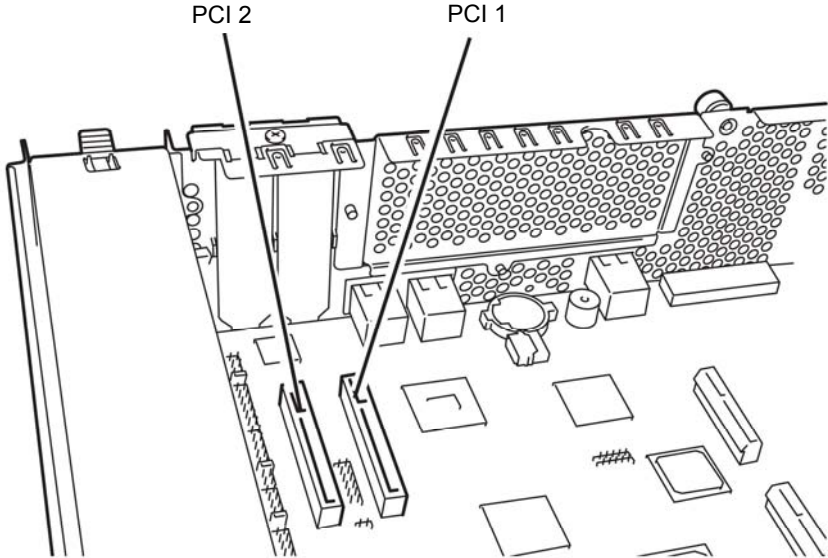

R320a-E4

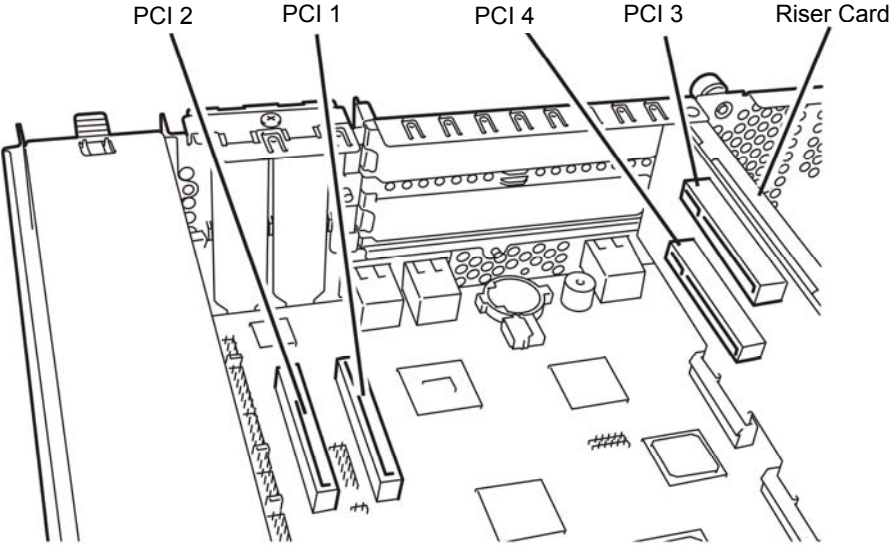

R320a-M4

List of option PCI boards and installable slots

■R320a-M4 model

N-code	Product name	PCI-1	PCI-2	PCI-3	PCI-4	Remarks	
		PCI slot performance	PCIe 1.1 x4 lane	PCIe 1.1 x4 lane	PCIe 2.0 x4 lane		PCIe 2.0 x4 lane
		Slot size	Low Profile		Full Height		
		PCI board type	x8 socket				
		Mountable board size	312 mm and less (long/short)		167.6 mm and less (MD 2)		
N8804-007	1000BASE-T 2ch board set	✓	✓	✓	✓	*1	
N8804-036	SCSI board	✓	✓	✓	✓	*2	
N8803-037	SAS board	✓	✓	✓	✓	*2	
N8803-035	Fibre Channel board set	✓	✓	✓	✓	*1	

*1 Exact the same board must be mounted into the same slot for each CPU/IO module 0, 1.

*2 Use N8803-036/037 by exclusion. These board can install to one piece by a total per the CPU/IO module and two pieces in a device.

■R320a-E4 model

N-code	Product name	PCI-1	PCI-2	PCI-3	PCI-4	Remarks	
		PCI slot performance	PCIe 1.1 x4 lane	PCIe 1.1 x4 lane	PCIe 2.0 x4 lane		PCIe 2.0 x4 lane
		Slot size	Low Profile		Full Height		
		PCI board type	x8 socket				
		Mountable board size	312 mm and less (long/short)		167.6 mm and less (MD 2)		
N8804-007	1000BASE-T 2ch board set	✓	✓	N/A	N/A	*1	
N8804-036	SCSI board	✓	✓	N/A	N/A	*2	
N8803-037	SAS board	✓	✓	N/A	N/A	*2	
N8803-035	Fibre Channel board set	✓	✓	N/A	N/A	*1	

*1 Exact the same board must be mounted into the same slot for each CPU/IO module 0, 1.

*2 Use N8803-036/037 by exclusion. These board can install to one piece by a total per the CPU/IO module and two pieces in a device.

Installing PCI Board

Follow the procedure below to install the board to be connected to the PCI board slot.

TIPS:

To install the PCI board, make sure the shape of the board connector matches with the shape of the PCI board slot connector.

Installing Low Profile PCI Board

1. Shut down the OS.
The server is automatically powered off.
2. Unplug the power cords.
3. Remove the CPU/IO module by referring to page 8-12.
4. Remove one screw that secures the stopper and remove it.

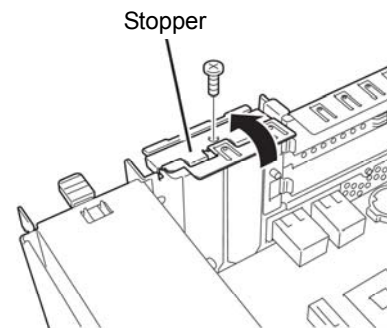

5. Verify the location of the CPU socket.
6. Remove the PCI bracket cover.

IMPORTANT:

Keep and store the removed PCI bracket cover with care.

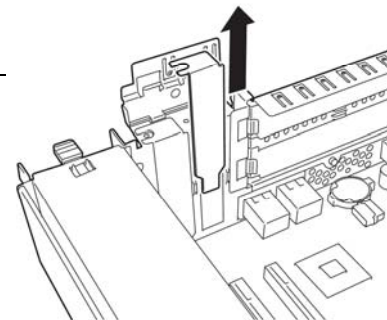

7. Install a PCI board in a PCI slot.

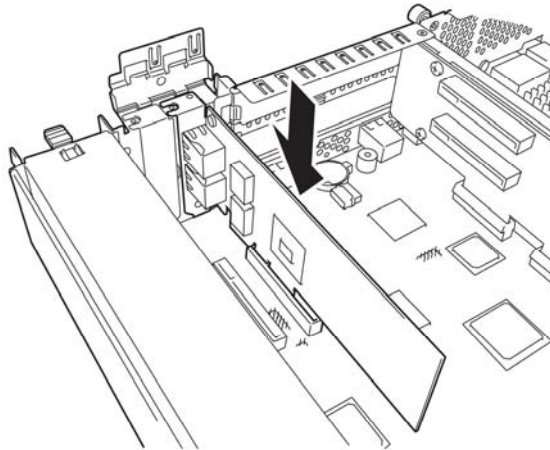

8. Install the stopper and secure with one screw.

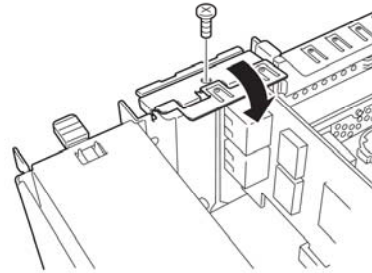

9. Refer to page 8-15 and install the CPU/IO module.
10. Plug the power cord.
11. Press the power switch and power on the server.
12. Verify that there is no error message displayed at POST screen.
If there is one, write down the error message and refer to 7-4 for the list of error messages.

Installing Full Height PCI Board

1. Shut down the OS.
The server is automatically powered off.
2. Unplug the power cords.
3. Remove the CPU/IO module referring to page 8-12.
4. Remove one screw that secures the stopper and remove it.

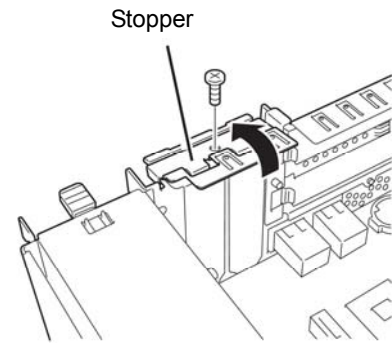

5. Remove three screws that secure the Riser Card, and remove it from the motherboard.

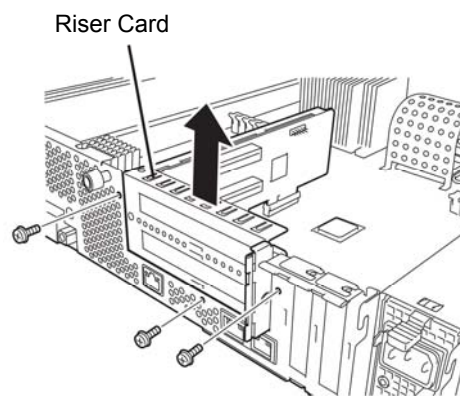

6. Remove one screw that secures the stopper and remove the stopper from the Riser Card.
7. Verify the location of the CPU socket.

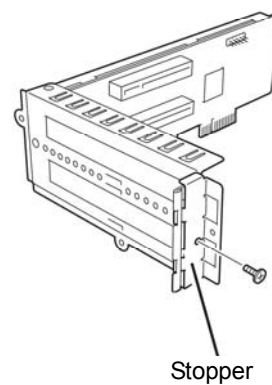

8. Remove the PCI bracket cover.

IMPORTANT:

Keep and store the removed PCI bracket cover with care.

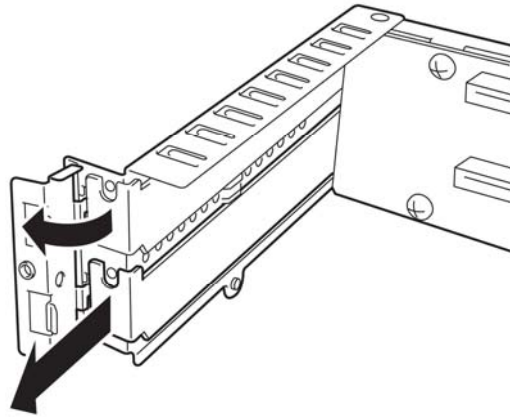

9. Install a PCI board in a PCI slot.

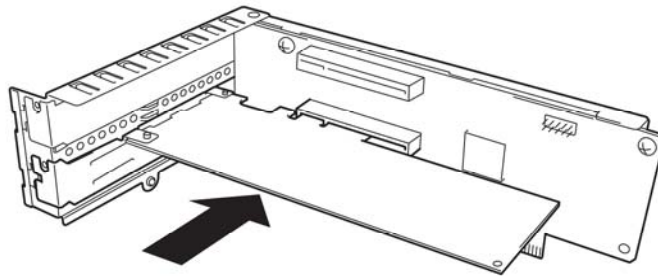

10. Install the stopper and secure with one screw.

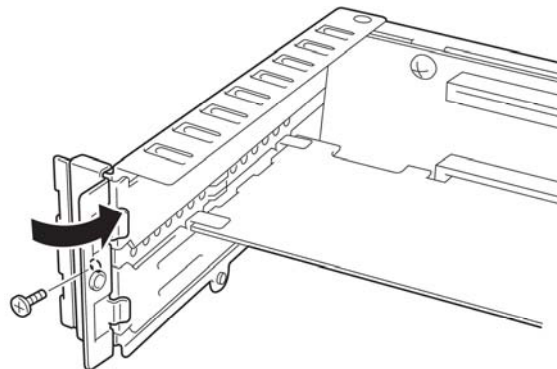

- 11.** Install a Riser Card on the motherboard and secure it with three screws.

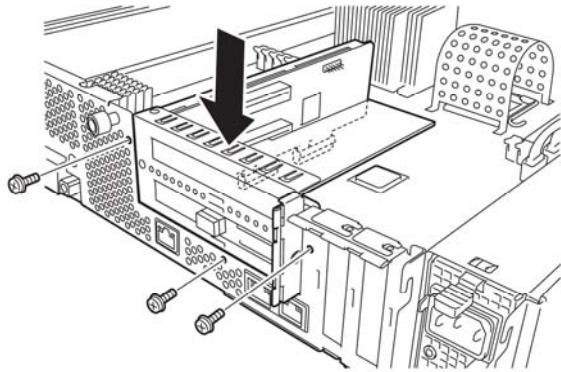

- 12.** Install the stopper and secure it with one screw.

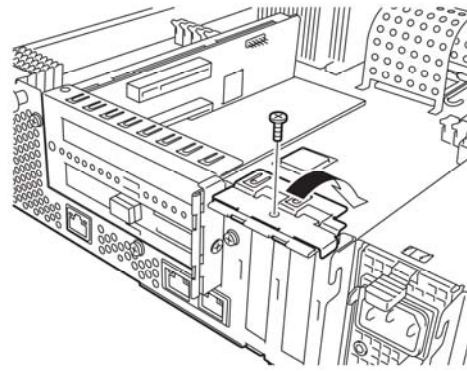

- 13.** Refer to page 8-15 and install the CPU/IO module.
- 14.** Plug the power cord.
- 15.** Press the power switch and power on the server.
- 16.** Verify that there is no error message displayed at POST screen.
If there is one, write down the error message and refer to 7-4 for the list of error messages.

Removing PCI Board

To remove PCI board card, follow the reverse procedure of the installation and install the expansion slot cover.

Replacing PCI Board

Follow the procedure below to replace the failed PCI board.

<Other than N8803-035 Fibre Channel Board Set>

1. Check the failed board from the event log.
2. Remove the CPU/IO module referring to the page 8-12.
3. Remove the PCI bracket, then remove the PCI board.
4. Replace the board and fasten it.
5. Install the CPU/IO module referring to the page 8-15.
6. Connect the network cable and cables for PCI boards.
7. The installed CPU/IO module will start automatically.
8. Confirm that the PCI board is correctly recognized by POST and OS.

<N8803-035 Fibre Channel Board set>

1. Check the failed board from the event log.
2. Remove the CPU/IO module referring to the page 8-12.
3. Configure WWPN of HBA (setting/confirming access control) newly installed on control software such as iStorageManager.
4. Remove the PCI bracket, then remove the PCI board.
5. Replace the board and fasten it.
6. Install the CPU/IO module referring to the page 8-15.
7. Connect the network cable and cables for PCI boards.
8. The installed CPU/IO module will start automatically.
9. Confirm that the PCI board is correctly recognized by POST and OS.

Setup of Optional PCI Board

IMPORTANT:

- To enable the fault-tolerant feature of the optional device, the identical PCI boards must be installed to the slots with the same number in CPU/IO module 0 and CPU/IO module 1.
 - The BIOS settings need to be modified when mounting some optional PCI boards. To change the BIOS settings, start the BIOS setup utility to change the [OS Boot Monitoring] configuration in [Server] – [Monitoring Configuration]. See page 4-24 for more details.
 - For the supported connecting devices, contact your sales agent.
-

N8804-007 1000BASE-T 2ch board set

IMPORTANT:

For LAN cable's connector, use a RJ-45 connector which is compliant with IEC8877 standard. If any other connector is used, it may not be removed easily.

- List of slots to install optional PCI boards
Refer to “List of option PCI boards and installable slots” on page 8-31.
- Driver installation procedure
You do not need to install drivers for N8804-007 board because they are included in the OS. After installing the boards, refer to 3-9 “Dual LAN Configuration” to set the dual LAN.

N8803-036 SCSI Board

- The lists of slots to install optional PCI boards

Refer to the table “List of option PCI boards and installable slots” on page 8-31.

- Driver installation procedure

You do not need the driver for N8803-032 because it is included in the OS. After installing the board, confirm the following directory exists by using the ls command.

```
/proc/scsi/aic79xx
```

If the directory above is not created, the board is recognized inappropriately.
(This directory exists only when the board is installed.)

N8803-037 SAS Board

Slots for Installation

Refer to “List of option PCI boards and installable slots” on page 8-32.

Installation Procedure

You do not need to install drivers for N8803-037 board because they are included in the OS..

N8803-035 Fibre Channel Board Set

- List of slots to install optional PCI boards

“List of option PCI boards and installable slots” on page 8-.32.

- Driver installation procedure

You do not need to install the driver for N8803-035 because it is included in the OS. However, you may need to add the following contents into /etc/modprobe.conf depending in your environment.

<N8190-119>

```
options lpfc lpfc_topology=0
```

<Other cases>

```
options lpfc lpfc_topology=6
```

After configuring above, use the following command to to reboot the system.

- (1) #sync
- (2) #reboot

Configuration of path duplexing

IMPORTANT:

This operation must be executed by only root user.

1. Execute following command to create multi path devise.

```
# multipath
```

Executing this command, dm devise of md-N and dm-mp devise (symbolic link to dm devise) of mapper/mpathN and mappae/mpathNpM (N and M is natural number except 1) are create under /dev.

Then sd devise of FibreChannel is made virtualization by each path.

mpathN is Nth LUN, mpathNpM is Mth partition.

2. Execute following command, and then begin path watch daemon (multipathd).

```
# chkconfig multipathd on  
# /etc/init.d/multipathd start
```

3. Execute following command, path condition of each dm-mp devise can be displayed.

- Altering procedure in running System

- altering partition

Execute fdisk to Virtualized /dev/mapper/mpathN (N is natural number except 1).

OS reboot is needed in order to reflect this altering to the System.

- Adding, altering, and deleting of LUN

OS reboot is needed in order to reflect this altering to the System.

(white paper)

Appendix A

Specifications

Item		NEC Express5800/R320a-E4 N8800-147F	NEC Express5800/R320a-M4 N8800-148F
CPU	Type	Intel® Xeon® Processor(E5504)	Intel® Xeon® Processor(X5570)
	Clock	2GHz	2.93GHz
	FSB	4.8GT/s	6.4GT/s
	Second cache	1MB	1MB
	Third cache	4MB	8MB
	Standard	Up to 1 processors (the number of processors installed per module)	
	Maximum	Up to 2 processors (the number of processors installed per module)	
Chipset		Intel 5500 Chipset + ICH10R	
Memory	Standard	None	
	Maximum	96GB (The standard DIMM must be replaced.)	
	Expansion unit	1 DIMM (2GB DIMM) 3 DIMM (4GB DIMM and 8GB DIMM)	
	Memory module	DDR3-1066 Registered DIMM	
	Error check	ECC	
Graphics (VRAM)		PILOT2 (32MB)	
	Optical Disk Drive (standard)	DVD-RAM (Load type: tray. Speed: x6)	
	Hard disk (standard)	None	
	Hard disk (maximum)	4.8TB*(300GB×16) * The user area is reduced to a half of the physical capacity due to software mirroring.	
File bay (2.5 inch)		16 slots	
Additional slot		PCI-ExpressREV1.1 x8slot x2	PCI-ExpressREV1.1 x8slot x2 PCI-ExpressREV2.0 x8slot x2
LAN interface		1000BASE-T x2	
External interface	USB	4-pin connector x4 Keyboard occupies one port.	
	Network	100/1000BASE-T x2, LAN for management x1	
	Display	MINI D-sub 15-pin x1	
Cabinet design		Rack-mount type	
External dimensions		483 (w) × 178 (h) × 736 (d) mm	
Weight		Max. 51.5kg	
Power supply		AC100V - 240V ±10%, 50/60Hz ±3Hz	
Power consumption		1400VA, 1390W	
Environmental requirements	In operation	Temperature 10 to 35°C Humidity 20 to 80% RH (non-condensing)	
	In storage	Temperature -10 to 55°C Humidity 20 to 80% RH (non-condensing)	
Bundled standard software		--	

Caution The sleep and hibernation function uncorresponds

N8800-147F, EXP320L
NEC Express5800/R320a-E4
N8800-148F, EXP320M
NEC Express5800/R320a-M4
User's Guide

1st Edition
1-2010
856-128382-111- A