

NEC Express Server
Express5800 Series

Express5800/T110g-S EXP285A User's Guide

Model Number: N8100-2195F/2196F



Chapter 1 General Description

Chapter 2 Preparations

Chapter 3 Setup

Chapter 4 Appendix

Documents for This Product

Documents for this product are provided as booklets () or as electronic manuals () in the EXPRESSBUILDER disc ().



Precautions for Use

Describes points of caution to ensure the safe use of this server.
Read these cautions before using this server.



Getting Started

Describes how to use this server, from unpacking to operations. See this guide at first and confirm an outline of this product.



EXPRESSBUILDER



User's Guide

Chapter 1: General Description	Overviews, names, and functions of the server's parts
Chapter 2: Preparations	Installation of additional options, connection of peripheral devices, and proper location for this server
Chapter 3: Setup	System BIOS configurations and summary of EXPRESSBUILDER
Chapter 4: Appendix	Specifications and other information



Installation Guide (Windows)

Chapter 1: Installing Windows	Installation of Windows and drivers, and important information for installation
Chapter 2: Installing the Bundled Software	Installation of bundled software, such as NEC ESMPRO and Universal RAID Utility



Maintenance Guide

Chapter 1: Maintenance	Server maintenance and troubleshooting
Chapter 2: Useful Features	The details of system BIOS settings, RAID Configuration Utility, and EXPRESSBUILDER
Chapter 3: Appendix	Error messages and Windows Event Logs











Other documents

Provides the details of NEC ESMPRO, Universal RAID Utility, and the other features.

Contents

Documents for This Product	2
Contents	3
Notations Used in This Document	7
Notations used in the text.....	7
Optical disk drive.....	7
Hard disk drive	7
Removable media	7
Abbreviations of Operating Systems(Windows)	8
Trademarks	9
License Notification	9
Regulatory Notices	10
Warnings and Additions to This Document	13
Latest editions	13
 Precautions for Use (Be Sure to Read).....	14
Safety precautions	14
Symbols used in this document and on warning labels.....	15
Safety notes	16
General	16
Power supply and power cord use.....	17
Installation, relocation, storage, and connection.....	19
Cleaning and working with internal devices	20
During operation	21
Warning labels	22
Handling precautions	23
Anti-static measures.....	24
Chapter 1 General Description.....	26
1. Introduction	27
2. Accessories.....	28
3. Standard Features	29
3.1 Management Features.....	31
3.2 Firmware and Software Version Management.....	32
4. Names and Functions of Parts.....	33
4.1 Front of the Server.....	33

4.2	Rear View	35
4.3	Internal View	36
4.4	Motherboard	38
4.5	Status Indicators	39
4.5.1	POWER LED ()	39
4.5.2	STATUS LED ()	40
4.5.3	Disk Access LED ()	41
4.5.4	Optical Disk Access LED	41
4.5.5	Disk LED.....	41
4.5.6	LINK/ACT LED ( ,  , )	42
4.5.7	SPEED LED ( ,  , )	42
Chapter 2	Preparations	43
I.	Installing Internal Optional Devices	44
1.1	Safety Precautions.....	44
1.2	Anti-static Measures	45
1.3	Overview of Installation and Removal.....	46
1.4	Removing the Side Cover	47
1.5	Removing the Front Bezel	48
1.6	Internal Flash Memory	49
1.6.1	Installation	49
1.6.2	Removal	49
1.7	TPM Kit.....	50
1.7.1	Installation	50
1.8	DIMM.....	51
1.8.1	Maximum supported memory size	52
1.8.2	Installation order	52
1.8.3	Installation	53
1.8.4	Removal	54
1.9	Use of Internal Hard Disk Drives in the RAID System	55
1.9.1	Notes on setting up a RAID System	58
1.10	Extra Battery for RAID Controller.....	60
1.10.1	Handling precautions	60
1.10.2	Installing N8103-155 extra battery	60
1.10.3	Removal	64
1.10.4	Installing the flash backup unit that comes with N8103-168	64
1.10.5	Removal	67
1.11	PCI Card.....	68
1.11.1	Notes	69
1.11.2	List of optional devices and installation slots	70

1.11.3	Installation	72
1.11.4	Configuration after installing	74
1.11.5	Removal	74
1.11.6	Installing the N8117-01A extra RS-232C connector kit	75
1.12	HDD Cages.....	77
1.12.1	Installing a 3.5-inch HDD cage and hard disk drives	78
1.12.2	Removing hard disk drives	79
1.12.3	Installing a 2.5-inch HDD cage and hard disk drives	80
1.12.4	Installing an extra 2.5-inch HDD cage	83
1.12.5	How to open the extra 2.5-inch HDD cage door	84
1.12.6	Installing the hard disk drive	85
1.13	Optical Disk Drive	86
1.13.1	Replacing drives	86
1.13.2	Removal	87
1.14	Backup Devices	88
1.14.1	Installation	89
1.14.2	Removal	89
1.15	Connecting Cables	90
1.15.1	Internal interface cables.....	90
1.15.2	Power cables	96
1.16	Attaching the Front Bezel.....	99
1.17	Installing the Side Cover	100
2.	Installation and Connection.....	101
2.1	Installation.....	101
2.1.1	Preparation for installation	103
2.2	Connection.....	105
2.2.1	Interface cables	106
2.2.2	Power cord	107
Chapter 3	Setup.....	108
1.	Turning on the Server.....	109
1.1	POST.....	110
1.1.1	POST sequence	110
1.1.2	POST error messages	111
2.	System BIOS Setup	112
2.1	Overview.....	112
2.2	Starting SETUP Utility.....	112
2.3	Usage of SETUP	113
2.4	Cases that Require Setting Changes.....	115

3. EXPRESSSCOPE ENGINE 3..... 117

3.1 Overview..... 117

3.2 EXPRESSSCOPE ENGINE 3 Network Configuration 118

4. EXPRESSBUILDER..... 120

4.1 Features of EXPRESSBUILDER 120

4.2 Usage of EXPRESSBUILDER 120

5. Installing Software Components 121

6. Turning off the Server..... 122

Chapter 4 Appendix 123

1. Specifications..... 124

1.1 Air Cooling System 124

1.2 Liquid Cooling System 127

2. Interrupt Lines 128

Notations Used in This Document

Notations used in the text

In addition to safety-related symbols urging caution, three other types of notations are used in this document. These notations have the following meanings.

Important	Indicates critical items that must be followed when handling the server or operating software. If the procedures described are not followed, <u>server failure, data loss, and other serious malfunctions could occur.</u>
Note	Indicates items that must be confirmed when handling the server or operating software.
Tips	Indicates information that is helpful to keep in mind when using this server.

Optical disk drive

This server is equipped with one of the following drives. These drives are referred to as *optical disk drive* in this document.

- DVD-ROM drive
- DVD Super MULTI drive

Hard disk drive

Unless otherwise stated, *hard disk drive* described in this document refers to the following.

- Hard disk drive (HDD)
- Solid state drive (SSD)

Removable media

Unless otherwise stated, *removable media* described in this document refers to the following.

- USB flash drive
- Flash FDD

Abbreviations of Operating Systems(Windows)

Windows Operating Systems are referred to as follows.

See Chapter 1 (1.2 Supported Windows OS) in Installation Guide (Windows) for detailed information.

Notations in this document	Official names of Windows
Windows Server 2012 R2	Windows Server 2012 R2 Standard
	Windows Server 2012 R2 Datacenter
	Windows Server 2012 R2 Foundation
Windows Server 2012	Windows Server 2012 Standard
	Windows Server 2012 Datacenter
Windows Server 2008 R2	Windows Server 2008 R2 Standard
	Windows Server 2008 R2 Enterprise
Windows Server 2008 *	Windows Server 2008 Standard
	Windows Server 2008 Enterprise

* Windows Server 2008 is 32-bit(x86) only in this manual.

Trademarks

EXPRESSSCOPE are registered trademarks of NEC Corporation.

Microsoft, Windows, Windows Server, Windows Vista, and MS-DOS are registered trademarks or trademarks of Microsoft Corporation in the United States and other countries. Intel, Pentium, and Xeon are registered trademarks of Intel Corporation of the United States. AT is a registered trademark of International Business Machines Corporation of the United States and other countries. Adaptec, its logo, and SCSI Select are registered trademarks or trademarks of Adaptec, Inc. of the United States. LSI and the LSI logo design are trademarks or registered trademarks of LSI Corporation. Adobe, the Adobe logo, and Acrobat are trademarks of Adobe Systems Incorporated. PCI Express is a trademark of Peripheral Component Interconnect Special Interest Group.

All other product, brand, or trade names used in this publication are the trademarks or registered trademarks of their respective trademark owners.

License Notification

The System BIOS of this product contains open source software for the following license.

EDK FROM TIANOCORE.ORG

BSD License from Intel

Copyright (c) 2004, Intel Corporation

All rights reserved.

Redistribution and use in source and binary forms, with or without modification, are permitted provided that the following conditions are met:

- Redistributions of source code must retain the above copyright notice, this list of conditions and the following disclaimer.
- Redistributions in binary form must reproduce the above copyright notice, this list of conditions and the following disclaimer in the documentation and/or other materials provided with the distribution.
- Neither the name of the Intel Corporation nor the names of its contributors may be used to endorse or promote products derived from this software without specific prior written permission.

THIS SOFTWARE IS PROVIDED BY THE COPYRIGHT HOLDERS AND CONTRIBUTORS "AS IS" AND ANY EXPRESS OR IMPLIED WARRANTIES, INCLUDING, BUT NOT LIMITED TO, THE IMPLIED WARRANTIES OF MERCHANTABILITY AND FITNESS FOR A PARTICULAR PURPOSE ARE DISCLAIMED. IN NO EVENT SHALL THE COPYRIGHT OWNER OR CONTRIBUTORS BE LIABLE FOR ANY DIRECT, INDIRECT, INCIDENTAL, SPECIAL, EXEMPLARY, OR CONSEQUENTIAL DAMAGES (INCLUDING, BUT NOT LIMITED TO, PROCUREMENT OF SUBSTITUTE GOODS OR SERVICES; LOSS OF USE, DATA, OR PROFITS; OR BUSINESS INTERRUPTION) HOWEVER CAUSED AND ON ANY THEORY OF LIABILITY, WHETHER IN CONTRACT, STRICT LIABILITY, OR TORT (INCLUDING NEGLIGENCE OR OTHERWISE) ARISING IN ANY WAY OUT OF THE USE OF THIS SOFTWARE, EVEN IF ADVISED OF THE POSSIBILITY OF SUCH DAMAGE.

Copyright (c) 2004 - 2007, Intel Corporation

All rights reserved. This program and the accompanying materials are licensed and made available under the terms and conditions of the BSD License which accompanies this distribution. The full text of the license may be found at <http://opensource.org/licenses/bsd-license.php>

THE PROGRAM IS DISTRIBUTED UNDER THE BSD LICENSE ON AN "AS IS" BASIS, WITHOUT WARRANTIES OR REPRESENTATIONS OF ANY KIND, EITHER EXPRESS OR IMPLIED.

Regulatory Notices

FCC Statement

This equipment has been tested and found to comply with the limits for a Class A digital device, pursuant to Part 15 of the FCC Rules. These limits are designed to provide reasonable protection against harmful interference when the equipment is operated in a commercial environment. This equipment generates, uses, and can radiate radio frequency energy and, if not installed and used in accordance with the instruction manual, may cause harmful interference to radio communications. Operation of this equipment in a residential area is likely to cause harmful interference in which case the user will be required to correct the interference at his own expense.

Industry Canada Class A Emission Compliance Statement/ Avis de conformité à la réglementation d'Industrie Canada:

CAN ICES-3(A)/NMB-3(A)

CE / Australia and New Zealand Statement

This is a Class A product. In domestic environment this product may cause radio interference in which case the user may be required to take adequate measures (EN55022).

BSMI Statement

警告使用者：

這是甲類的資訊產品，在居住的環境中使用時，可能會造成射頻干擾，在這種情況下，使用者會被要求採取某些適當的對策。

Disposing of your used product



In the European Union

EU-wide legislation as implemented in each Member State requires that used electrical and electronic products carrying the mark (left) must be disposed of separately from normal household waste. This includes Information and Communication Technology (ICT) equipment or electrical accessories, such as cables or DVDs.

When disposing of used products, you should comply with applicable legislation or agreements you may have. The mark on the electrical and electronic products only applies to the current European Union Member States.

Outside the European Union

If you wish to dispose of used electrical and electronic products outside the European Union, please contact your local authority and ask for the correct method of disposal.

Turkish RoHS information relevant for Turkish market

EEE Yönetmeliğine Uygundur

CCC声明

声明

此为A级产品, 在生活环境中, 该产品可能会造成无线电干扰。在这种情况下, 可能需要用户对其干扰采取切实可行的措施。

部件名称	有毒有害物质或元素					
	铅 (Pb)	汞 (Hg)	镉 (Cd)	六价铬 (Cr(VI))	多溴联苯 (PBB)	多溴二苯醚 (PBDE)
印刷线路板	×	○	○	○	○	○
HDD、DVD等	×	○	○	○	○	○
机箱、支架	○	○	○	○	○	○
电源	×	○	○	○	○	○
键盘	×	○	○	○	○	○
其他(电缆、鼠标等)	×	○	○	○	○	○

○: 表示该有毒有害物质在该部件所有均质材料中的含量均在SJ/T11363-2006标准规定的限量要求以下。
×: 表示该有毒有害物质至少在该部件的某一均质材料中的含量超出SJ/T11363-2006标准规定的限量要求。

Vietnam RoHS information relevant for Vietnam market

Complying with "CIRCULAR, No.30/2011/TT-BCT (Hanoi, August 10 2011), Temporary regulations on content limit for certain hazardous substances in electrical products"



廢電池請回收

警告:
如果更換錯誤電池會產生爆炸請以相同或同型電池更換使用

Declaration of Conformity
with the requirements of Technical Regulation on the Restriction Of the use of certain Hazardous Substances in Electrical and Electronic Equipment
(adopted by Order №1057 of Cabinet of Ministers of Ukraine)

The Product is in conformity with the requirements of Technical Regulation on the Restriction Of the use of certain Hazardous Substances in electrical and electronic equipment (TR on RoHS).

The content of hazardous substance with the exemption of the applications listed in the Annex №2 of TR on RoHS:

1. Lead (Pb) – not over 0,1wt % or 1000wt ppm;
2. Cadmium (Cd) – not over 0,01wt % or 100wt ppm;
3. Mercury (Hg) – not over 0,1wt % or 1000wt ppm;
4. Hexavalent chromium (Cr6+) – not over 0,1wt % or 1000wt ppm;
5. Polybrominated biphenyls (PBBs) – not over 0,1wt % or 1000wt ppm;
6. Polybrominated diphenyl ethers (PBDEs) – not over 0,1wt % or 1000wt ppm.

Декларація про Відповідність
Вимогам Технічного Регламенту Обмеження Використання деяких Небезпечних Речовин в
електричному та електронному обладнанні
(затвердженого Постановою №1057 Кабінету Міністрів України)

Виріб відповідає вимогам Технічного Регламенту Обмеження Використання деяких Небезпечних Речовин в електричному та електронному обладнанні (ТР ОВНР).

Вміст небезпечних речовин у випадках, не обумовлених в Додатку №2 ТР ОВНР, :

1. свинець (Pb) – не перевищує 0,1 % ваги речовини або в концентрації до 1000 частин на мільйон;
2. кадмій (Cd) – не перевищує 0,01 % ваги речовини або в концентрації до 100 частин на мільйон;
3. ртуть (Hg) – не перевищує 0,1 % ваги речовини або в концентрації до 1000 частин на мільйон;
4. шестивалентний хром (Cr6+) – не перевищує 0,1 % ваги речовини або в концентрації до 1000 частин на мільйон;
5. полібромбіфеноли (PBВ) – не перевищує 0,1% ваги речовини або в концентрації до 1000 частин на мільйон;
6. полібромдефенілові ефіри (PBDE) – не перевищує 0,1 % ваги речовини або в концентрації до 1000 частин на мільйон.

Декларация о Соответствии
Требованиям Технического Регламента об Ограничении Использования некоторых Вредных
Веществ в электрическом и электронном оборудовании
(утверждённого Постановлением №1057 Кабинета Министров Украины)

Изделие соответствует требованиям Технического Регламента об Ограничении Использования некоторых Вредных Веществ в электрическом и электронном оборудовании (ТР ОИВВ).

Содержание вредных веществ в случаях, не предусмотренных Дополнением №2 ТР ОИВВ:

1. свинец (Pb) – не превышает 0,1 % веса вещества или в концентрации до 1000 миллионных частей;
2. кадмий (Cd) – не превышает 0,01 % веса вещества или в концентрации до 100 миллионных частей;
3. ртуть (Hg) – не превышает 0,1 % веса вещества или в концентрации до 1000 миллионных частей;
4. шестивалентный хром (Cr6+) – не превышает 0,1 % веса вещества или в концентрации до 1000 миллионных частей;
5. полибромбифенолы (PBВ) – не превышает 0,1 % веса вещества или в концентрации до 1000 миллионных частей;
6. полибромдифеноловые эфиры (PBDE) – не превышает 0,1 % веса вещества или в концентрации до 1000 миллионных частей.

Warnings and Additions to This Document

1. Unauthorized reproduction of the contents of this document, in part or in its entirety, is prohibited.
2. This document is subject to change at any time without notice.
3. Do not make copies or alter the document content without permission from NEC Corporation.
4. If you have any concerns, or discover errors or omissions in this document, contact your sales representative.
5. Regardless of article 4, NEC Corporation assumes no responsibility for effects resulting from your operations.
6. The sample values used in this document are not the actual values.

Keep this document for future reference.

Latest editions

This document was created based on the information available at the time of its creation. The screen images, messages and procedures are subject to change without notice. Substitute as appropriate when content has been modified.

The most recent version of the guide, as well as other related documents, is also available for download from the following website.

<http://www.nec.com/>



Precautions for Use (Be Sure to Read)

The following provides information required to use your server safely and properly. For details of names in this section, see *Names and Functions of Parts* in this document.

Safety precautions

Follow the instructions in this document for the safe use of the NEC Express server.

This guide describes hazardous parts of the server, possible hazards, and how to avoid them. Server components with possible danger are indicated with a warning label placed on or around them.

WARNING or **CAUTION** is used to indicate a danger in this guide or on warning labels. Each term is defined as follows:



Indicates there is a risk of death or serious personal injury



Indicates there is a risk of burns, other personal injury, or property damage

Precautions and notices against hazards are presented with one of the following three symbols. Each symbol is defined as follows:

	Attention	This symbol indicates the presence of a hazard if the instruction is ignored. An image in the symbol illustrates the hazard type.	(Example) (Electric shock risk)
	Prohibited Action	This symbol indicates prohibited actions. An image in the symbol illustrates a particular prohibited action.	(Example) (Do not disassemble)
	Mandatory Action	This symbol indicates mandatory actions. An image in the symbol illustrates a mandatory action to avoid a particular hazard.	(Example) (Disconnect a plug)

(A label example used in this guide)

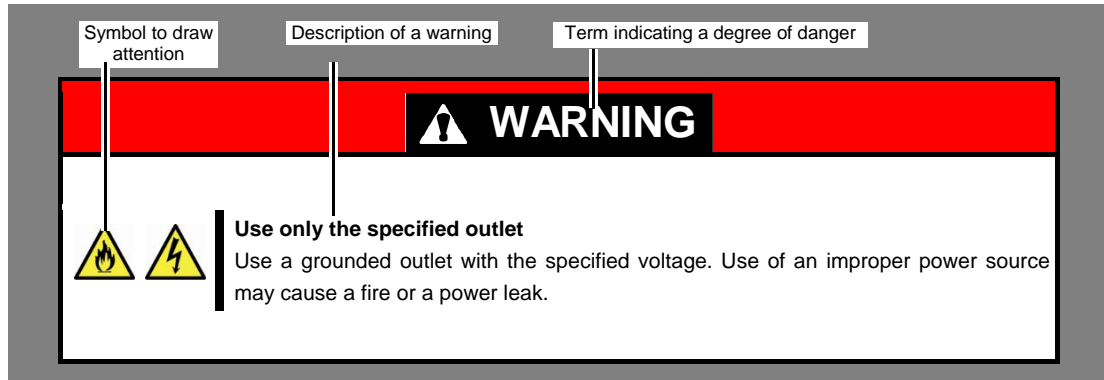

Symbols used in this document and on warning labels

Attentions

	Indicates the presence of electric shock hazards.		Indicates the presence of mechanical parts that can result in bodily injury.
	Indicates the presence of a hot surface or component. Touching this surface could result in bodily injury.		Indicates the presence of mechanical parts that can result in pinching or other bodily injury.
	Indicates there is a risk of explosion.		Indicates the presence of laser beam that cause blindness.
	Indicates there is a risk of fire or fumes.		Indicates a general notice or warning that cannot be specifically identified.

Prohibited Actions

	Do not disassemble, repair, or modify the server. Otherwise, an electric shock or fire may be caused.		Do not touch the server with wet hand. Otherwise, an electric shock may be caused.
	Do not touch the component specified by this symbol. Otherwise, an electric shock or burn may be caused.		Do not use the server in the place where water or liquid may pour. Otherwise, an electric shock or fire may be caused.
	Do not place the server near the fire. Otherwise, a fire may be caused.		Indicates a general prohibited action that cannot be specifically identified.







Mandatory Actions





	Unplug the power cord of the server. Otherwise, an electric shock or fire may be caused.		Indicates a mandatory action that cannot be specifically identified. Make sure to follow the instruction.
	Make sure equipment is properly grounded. Otherwise, an electric shock or fire may be caused.		

Safety notes

This section provides notes on using the server safely. Read this section carefully to ensure proper and safe use of the server. For symbols, see *Safety precautions*.

General

 WARNING	
	<p>Do not use the server for services where human life may be at stake or high reliability is required.</p> <p>This server is not intended for use in medical, nuclear, aerospace, mass transit or other applications where human life may be at stake or high reliability is required, nor is it intended for use in controlling such applications. We disclaim liability for any personal injury and property damages caused by such use of this server.</p>
 	<p>Do not use the server if any smoke, odor, or noise is present.</p> <p>If smoke, odor, or noise is present, immediately turn off the server and disconnect the power plug from the outlet, then contact the store where you purchased the product or your maintenance service company. Using the server in such conditions may cause a fire.</p>
 	<p>Do not insert needles or metal objects.</p> <p>Do not insert needles or metal objects into ventilation holes in the server or openings in the optical disk drive. Doing so may cause an electric shock.</p>

 CAUTION	
  	<p>Keep water or foreign matter away from the server.</p> <p>Do not let any liquid such as water or foreign materials including pins or paper clips enter the server. Failure to follow this warning may cause an electric shock, a fire, or failure of the server. When such things accidentally enter the server, immediately turn off the power and disconnect the power plug from the outlet. Do not disassemble the server, and contact the store where you purchased the product or your maintenance service company.</p>

Power supply and power cord use

WARNING



Do not hold the power plug with a wet hand.

Do not disconnect/connect the plug while your hands are wet. Failure to follow this warning may cause an electric shock.



Do not connect the ground wire to a gas pipe.

Never connect the ground wire to a gas pipe. Failure to follow this warning may cause a gas explosion.

CAUTION



Plug in to a proper power source.

Use a grounded outlet and observe the specified voltage. Use of an improper power source may cause a fire or a power leak.

Do not install the server where you need an extension cord. Use of a cord that does not meet the power specifications of the server may heat up the cord and cause a fire.

If you want to use an AC cord set with a ground wire of class OI, be sure to connect the ground wire before inserting the power plug into the outlet. Before disconnecting the ground wire, be sure to disconnect the power plug from the output.



Do not connect many cords into a single outlet by using extension cords.

The electric current exceeding the rated flow overheats the outlet, which may cause a fire.



Do not pull out a cable by gripping the cable part.

Pull a cable straight out by gripping the connector part. Pulling a cable by gripping the cable part or applying extra pressure to the connector part may damage the cable part, which may cause a fire or electric shock.



Insert the power plug into the outlet as far as it goes.

Heat generation resulting from a halfway inserted power plug (imperfect contact) may cause a fire. Heat will also be generated if condensation is formed on dusty blades of the halfway inserted plug, increasing the possibility of fire.

 **CAUTION**
Do not use any unauthorized interface cable.

Use only the interface cables provided with the server. Electric current that exceeds the amount allowed could cause fire.

Also, observe the following precautions to prevent electrical shock or fire caused by a damaged power cord.



- Do not stretch the cord harness
- Do not bend the power cord.
- Do not twist the power cord
- Do not step on the power cord.
- Uncoil the power cord before use
- Do not secure the power cord with staples or equivalents
- Do not pinch the power cord
- Keep chemicals away from the power cord
- Do not place any object on the power cord
- Do not alter, modify, or repair the power cord
- Do not use a damaged power cord (replace the damaged power cord with a power cord of the same standard. For information on replacing the power cord, contact the store where you purchased the product or a maintenance service company)

**Do not use the attached power cord for any other devices or usage.**

The power cord that comes with your server is designed aiming to connect with this server and to use with the server, and its safety has been tested. Do not use the attached power cord for any other purpose. Doing so may cause a fire or an electric shock.

Installation, relocation, storage, and connection

CAUTION



Do not attempt to lift the server by holding the front bezel.

Securely hold the server by the base to move or lift. Do not attempt to lift it by holding the front bezel. Doing so may cause the front bezel to come off, which may cause not only breakage of the server but also cause the server to fall on to persons resulting in personal injury.



Do not install the server in any place other than specified.

Do not install the server in the following places or any place other than specified in this User's Guide. Failure to follow this instruction may cause a fire.

- A dusty place
- A humid place such as near a boiler
- A place exposed to direct sunlight
- An unstable place



Do not use the server in an environment where corrosive gas is present

Do not install the server in a place subject to corrosive gases including sodium chloride, sulfur dioxide, hydrogen sulfide, nitrogen dioxide, chlorine, ammonia, or ozone. Do not install the server in an environment that contains dust, chemicals that accelerate corrosion such as NaCl or sulfur, or conductive materials. Failure to follow this warning may cause the wiring on the printed wiring board to short-circuit, leading to fire. If you have any questions, contact the store where you purchased the product or a maintenance service company.



Do not connect or disconnect any interface cable with the power cord of the server plugged to a power source.

Be sure to power off the server and unplug the power cord from a power outlet before installing/removing any optional internal device or connecting/disconnecting any interface cable to/from the server. If the server is off-powered but its power cord is plugged to a power source, touching an internal device, cable, or connector may cause an electric shock or a fire resulted from a short circuit.



Use only the specified interface cable.

Use only interface cables provided by NEC and locate a proper device and connector before connecting a cable. Using an authorized cable or connecting a cable to an improper destination may cause a short circuit, resulting in a fire.

Also, observe the following notes on using and connecting an interface cable.

- Do not use any damaged cable connector.
- Do not step on the cable.
- Do not place any object on the cable.
- Do not use the server with loose cable connections.
- Do not use any damaged cable.

Cleaning and working with internal devices

WARNING



Do not disassemble, repair, or alter the server.

Never attempt to disassemble, repair, or alter the server on any occasion except as described in this document. Failure to follow this warning may cause not only malfunction of the server but also an electric shock or fire.



Do not look into the optical disk drive

A laser beam used in the optical disk is harmful to the eyes. Do not look into or insert a mirror into the drive while the drive is powered on. If a laser beam (which is invisible) enters your eyes, you may lose your eyesight.



Do not attempt to remove lithium, NiMH, or Li-ion batteries.

The server contains the lithium, NiMH, or Li-ion battery (some optional devices have a lithium, NiMH, or Li-ion battery installed). Do not remove the battery. Placing a battery close to a fire or in the water may cause an explosion.

When the server does not operate appropriately due to the dead battery, contact the store you purchased the product or your maintenance service company. Do not attempt to disassemble the server to replace or recharge the battery by yourself.

CAUTION



High temperature

Components including internal Hard Disk Drives in the server are extremely hot just after the server is turned off. Allow the surface to cool before installing/removing.



Secure cables or cards in place

Be sure to secure the power cord, interface cables, and cards in place. Incomplete installation causes a loose connection, resulting in smoke or fire

During operation

CAUTION



Avoid contact with the server during thunderstorms.

Do not touch any part of the server including the cables when a thunderstorm is approaching. Also, do not connect or disconnect any devices. There may be a risk of electric shock from lightning strike.



Keep animals away from the server.

Keep animals such as pets away from the server. Pet hair or other waste enters the server, which may cause a fire or electric shock.



Do not place any object on top of vertically mounted servers.

Any weight on the server may cause the server to fall, resulting in personal injury or property damage.



Do not place any object that weighs 5 kg or more on top of horizontally mounted servers.

The maximum weight that can be placed on top of the server when it is horizontally mounted is 5 kg. Do not place any object weighing 5 kg or more on top of the server. Failure to observe this limit may deform the server, which could cause a failure.



Do not leave the optical disk drive tray open.

Dust may get in the server when the tray is open, which may result in a malfunction. In addition, bumping the open tray could cause personal injury.



Do not get yourself caught in the fan

Keep your hands and hair away from the cooling fan at the rear of the server during operation. Failure to observe this warning may cause your hands or hair to catch in the fan, resulting in personal injury.

Warning labels

Warning labels are attached on or near the components with potential hazards to draw attention from users to potential hazards involved in handling the server. This label is either attached or printed on the component. Do not remove or black out this label and keep it clean. If no label is attached or printed on the server, or if there is a label coming off or stained, contact your sales representative.

⚠ 注意 CAUTION ATTENTION

本製品を横置きした場合の耐荷重は5kg未満です。
5kg以上の物を載せないで下さい。

本产品平放时承载重量为 5KG 以下。
请不要在本机上放置 5KG 以上的物品。

The withstand load when this product is put in side is less than 5kg.
Do not put the thing of 5kg or more.

La charge de tenue quand ce produit est mis à l'intérieur est moins de 5 kilogrammes.
Ne mettez pas un objet de 5 kilogrammes ou plus.

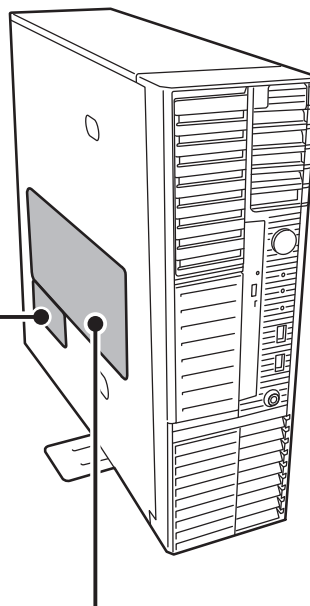

⚠ 注意 CAUTION ATTENTION	
<p>高温になるコンポーネントがあります。十分に冷えてから触れるようにして下さい。 As some components may become very hot during system operation, give ample time to allow cooling as well as use precaution when handling internal components immediately after powering down. 有的部件可能会达到高温。请注意待其冷却之后再接触。</p> <p>有的组件可能会达到高温。请注意待其冷却之后再接触。</p> <p>Comme certains composants peuvent se réchauffer beaucoup pendant le fonctionnement du système, laissez-les se refroidir suffisamment et faites bien attention lorsque vous manipulez les composants internes juste après avoir désactivé le système.</p>	<p>ネジは本体内部へ落とさない様、十分ご注意ください。 Do not drop any screws inside the system. 请一定注意不要让螺丝掉入设备内部。 请注意绝对不要将螺丝掉入设备内部。 Ne laissez tomber aucune vis à l'intérieur du système.</p>
<p>電源を切ってもバッテリーで稼働している部分があります。 保守をする前に全てのコンポーネントの取り扱い説明書をお読みください。 Some internal components may still be operational on battery power. Refer to instruction manuals for this system as well as options prior to maintenance. 即使切断电源，有的部件也会依靠电池运转。在进行维护之前，请认真阅读各组件的使用说明书。</p> <p>即使切断电源，有的组件也会依靠电池运转。 在进行维护之前，请事先阅读各组件的使用说明书。 Quelques composants internes peuvent encore continuer à fonctionner avec l'alimentation de la batterie. Référez-vous aux manuels d'instruction pour ces systèmes aussi bien que les dispositifs en options avant d'effectuer les travaux d'entretien.</p>	<p>ボード及びオプション機器の接続の際は、必ずユーザースタンドを参照し、正しく接続して下さい。 誤った接続は、故障や火災の原因となります。 Refer to the "User's Guide" when option board or peripherals are installed. Incorrect installations may result in damage to the system and lead to accidents. 连接板卡及可选设备时，请务必参照“用户指南”进行正确连接。 连接错误，有可能造成故障或火灾。 安装控制卡及选配件时，请务必参照“用户指南”进行正确连接。 连接错误时，可能会造成故障或火灾。 Référez-vous au «Guide de l'utilisateur» lorsque des cartes en option ou des périphériques sont installés. Une installation incorrecte risque d'endommager le système et de causer des accidents.</p>
<p>オプションの取付け、取外し時はすべての電源プラグをコンセントから抜き、外部装置と接続しているケーブルを外して下さい。 Disconnect all AC power cords from both system and external peripherals prior to installing/removing options. 进行可选配件的安装和拆卸时，请先从插座拔下全部的电源插头并分离与外部设备间的线缆。拆卸时请同时拔掉所有电源，否则无法断电。 进行选配件的安装和拆卸时，请先把全部的电源插头从插座中拔出，並取下與外部設備連接的線纜。 Déconnectez tous les câbles CA du système et des périphériques externes avant d'installer/d'enlever les dispositifs en option.</p>	<p>指をさんだり、ぶつけたりしないように注意して下さい。 To avoid the risk of personal injury, be careful when accessing the inside of the system. 请小心不要夹住或划伤手指。 请注意不要夹伤手指，或因碰撞而受伤。 Pour éviter tout risque de blessure, faites attention en accédant à l'intérieur du système.</p> <p>装置の持ち上げ、移動の際は、装置の底面をしっかりと持ち上げて下さい。 Firmly hold the bottom of the system when required to lift and carry the system. 抬起、移动设备时，请牢固抓住设备底部将其抬起。 抬起、搬運向服務時，請牢實抓住設備底部將其抬起。 Saisissez fermement le fond du système au cas où vous devez soulever et transporter le système.</p>

Handling precautions

Confirm the following precautions.

- Do not use any cell phone or PHS and switch off them near the server. Electric waves from such devices can cause server to malfunction.
- Install the server in an appropriate place. For details about the location, see *Chapter 2 (2. Installation and Connection)*.
- Make sure that the server is off and unplug the power cord before connecting/removing cables to/from peripheral devices if they are not plug-and-play devices.
- Connect the provided power cord to a 100 VAC outlet. If an optional cable is used, you can connect to a 100 or 200 VAC power system.
- Make sure that the access LED on the server is off before turning off the power or ejecting an optical disk.
- Wait for at least 30 seconds before turning on the server after turning off the server. If any Uninterruptible Power Supply (UPS) unit is connected, set it to wait for at least 30 seconds before turning on the server after power off. If the optional RAID Controller N8103-168 is installed, wait for at least 90 seconds before turning on the server after turning off the power.
- Turn off the server and unplug the power cord before moving it.
- Regularly clean the server to prevent various types of failure. See *Chapter 1 (2. Daily Maintenance)* in "*Maintenance Guide*" for details about cleaning.
- Check the system clock approximately once per month. Use of a time server (NTP server) is recommended.
- We recommend you store the server at room temperature. Keep the following storage conditions.
Temperature: -10°C to 55°C, Humidity: 20% to 80%, No condensation of moisture
- Do not use the server, or removable/backup media such as tape cartridges when moving them from a cold place to a warm place. The condensation will occur and cause malfunctions and failures when these are used in such state. Use the server after waiting sufficiently.
Reference: Time effective at avoiding condensation in winter (10°C or more differences between the room temperature and atmospheric temperature)
 - Disk devices: Approximately 2 to 3 hours
 - Tape media: Approximately 1 day
- If you use the third party optional device to the server, and it causes failure, a charge for repairing must be paid even within warranty period.

Anti-static measures

This product contains static-sensitive electronic components. Follow the measures below to avoid a failure caused by static electricity when installing or uninstalling any optional device.

- **Wearing Anti-static Wrist Strap or Anti-static Gloves**

Wear a wrist strap on your wrist and connect the wire to the chassis. If there is no wrist strap, touch an unpainted metal surface of the chassis connected to the ground to discharge static electricity from your body before touching the component. Touch the metal part occasionally to discharge the static electricity while working on the component.

- **Checking the Workplace**

- Work on an anti-static floor or concrete floor.
- If you work on a place where static electricity is likely to be generated (e.g. carpet), be sure to provide anti-static protection.

- **Using the Work Table**

Place the server on a mat with Electrostatic Discharge (ESD) protection.

- **Clothing**

- Do not wear wool or synthetic clothes.
- Wear anti-static shoes.
- Remove any kind of metal accessories such as a ring, bracelet or wrist watch.

- **Handling of Components**

- Keep the component in an anti-static bag until you install it to the server.
- Hold the component by the edges to avoid touching any terminals or mounting parts.
- Place the component in an anti-static bag when storing or moving them.

- **Handling of Cables**

When connecting a cable (e.g., LAN cable), static electricity may also be charged due to friction against the floor.

Connecting the charged cable with an I/O device may cause damage to the devices in the system. It is recommended to use a product such as electrostatic discharge kit to eliminate the static charge before connecting the cable.

- **Installing and Uninstalling the Optional Device**

- To avoid electric hazard and malfunction, be sure to turn off the power switch of the server and unplug the power cord from the outlet before installing or uninstalling any optional device. If the device is hot-swappable, you do not need to turn off the power switch and unplug the power cord.
- The device contains static-sensitive electronic components. When installing or uninstalling the optional device, wear an anti-static wrist strap on your wrist to avoid a failure caused by the static electricity. To use the strap, connect the wire to the chassis.

Tips for your health and safety

Using a computer extensively may affect different parts of your body. Here are tips you should follow while working on a computer to minimize strain on your body.

Keep proper posture

The basic body position for using a computer is sitting straight with your hands on the keyboard parallel with the floor, and your eyes directed slightly downward toward the monitor. With the proper posture described above, no unnecessary strain is applied on any part of your body, in other words when your muscles are most relaxed.

Working on the computer with bad posture such as hunching over or being too close to the monitor could cause fatigue or deteriorated eyesight.



Adjust the angle of your display

Most display units are designed for adjustment of the horizontal and vertical angles. This adjustment is important to prevent the screen from reflecting bright lights and to make the display contents easy to see. Working without adjusting the display to a comfortable angle makes it difficult for you to maintain a proper posture and you will get tired easily. Adjust the viewing angle before use.

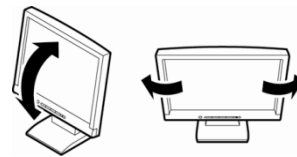

Adjust the brightness and contrast of the display

Display screens have functions to control brightness and contrast. The most suitable brightness/contrast depends on age, individuals, and environment, so adjust it to suit your preferences. A too bright or too dark display is bad for your eyes.

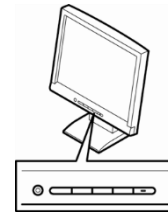

Adjust the angle of keyboard

Some keyboards are ergonomically designed, which allow the angle to be adjusted. Adjusting the angle of the keyboard is effective to reduce tension on your shoulders, arms, and fingers.



Clean your equipment

Keeping your equipment clean is important not only for the appearance but also for functional and safety reasons. A dusty monitor makes it difficult to see the display contents, so clean it regularly.

Take rest breaks

When you feel tired, take a break. Light exercise is also recommended.



General Description

This chapter introduces the features of this server and explains the name of each part.

1. Introduction

2. Accessories

Explains the server's accessories.

3. Standard Features

Explains the server's feature.

4. Names and Functions of Parts

Explains the name of each part contained in the server.

***1.* Introduction**

Thank you for purchasing this NEC Express5800 Series product.

This high performance server is powered by the latest Intel® processor "Intel® Xeon® processor".

NEC's latest technology and architectures realize high-power and high-speed operation that cannot be matched by existing servers.

The server is designed with consideration of not only reliability but also expandability, which enables you to use it as a network server.

To use the server correctly and to bring out the server's performance, read this document carefully.

2. Accessories

The carton box contains various accessories which are required for setup or maintenance. **Make sure you have them all** for future use.

- Keyboard × 1
- Mouse × 1
- Rubber Foot × 4
- Bezel Lock Key × 2^{*1}
- Screw set for fix to backup device × 1
- EXPRESSBUILDER^{*2} × 1
- Getting Started × 1
- Power Cord × 1
- SDR Update CD-ROM × 1
- Cable Tie (for securing AC power cord) × 1
- Cable Tie (for Battery cable fixing) × 1

*1 Requires 2.5-inch HDD cage.

*2 Instruction manuals are stored in the PDF format on the EXPRESSBUILDER disc. Install Adobe Reader into your computer to read them.

Make sure you have all accessories and inspect them. If an accessory is missing or damaged, contact your sales representative.

3. Standard Features

The server has the following standard features:

High performance

- Intel® Xeon®, Core™ i3, Pentium® processor
- High-speed memory access (DDR3 1600 supported)
- High-speed disk access (SATA2 6 Gbps, SAS 6 Gbps supported)
- High-speed 1000BASE-T (2 ports) interface (1 Gbps/100 Mbps/10 Mbps supported)

High reliability

- Memory monitoring feature (error correction/error detection)
- Memory degeneracy feature (logical isolation of a failed device)
- Bus parity error detection
- Temperature detection
- Error detection
- Internal fan monitoring feature
- Internal voltage monitoring feature
- RAID system (disk array)
- BIOS password feature

Management utilities

- NEC ESM PRO
- ExpressUpdate
- Remote controlling feature (EXPRESSSCOPE Engine 3)
- RAID system management utility (Universal RAID Utility)
- Hard disk drive monitoring

Power saving and noiseless design

- Power monitoring feature
- Power control feature
- High-efficiency power supply supporting 80 PLUS® Platinum
- Fan control appropriate to environment, work load, and configuration
- Enhanced Intel SpeedStep® Technology supported

Expandability

- Various IO option slots
 - PCI Express 3.0 (x 16 lanes) : 1 slot (low profile)
 - PCI Express 2.0 (x 4 lanes): 1 slot (low profile)
 - PCI Express 2.0 (x 1 lanes): 2 slots (low profile)
- Large memory of up to 32 GB
- Backup device bay provided as standard
- USB 3.0 interface (requires the supporting OS)
- Three LAN connectors (one for management LAN)

Ready to use

- Hard disk drives can be installed with one-touch setup, which requires no cables (hot swap supported)

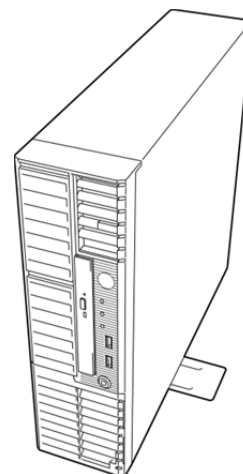

Various built-in features

- El Torito Bootable CD-ROM (no emulation mode) format supported
- Software power-off
- Remote power-on feature
- AC-Link feature
- Remote console feature
- Baseboard Management Controller (BMC) conforming to IPMI v2.0

Self-diagnosis

- Power On Self-Test (POST)
- Test and Diagnosis (T&D) utility

Easy setup

- EXPRESSBUILDER (OS setup utility)
- BIOS setup utility (SETUP)

Maintenance features

- Off-line tool
- Memory dump feature using the DUMP switch
- Feature to back up and restore BIOS/BMC settings using the EXPRESSSCOPE profile key

3.1 Management Features

The hardware components of the server provide operation control/reliability features as shown below. Additionally, *NEC ESMPRO Agent*, which is provided in EXPRESSBUILDER, enables you to collectively manage the state of your systems. You can also monitor the status of the server from a PC to manage the network where NEC ESMPRO Manager provided in EXPRESSBUILDER is installed.

The features available on this server are as shown in the table below.

Function	Availability	Description
Hardware		Shows physical hardware information.
Memory bank	○	Shows physical memory information.
Device info	○	Shows information specific to the server.
CPU	○	Shows physical CPU information.
System	○	Shows logical CPU information and monitors the load factor. Shows logical memory information and monitors the status.
I/O device	○	Shows information on I/O devices (serial ports, keyboard, mouse, and video).
System environment		
Temperature	○	Monitors the temperature inside of the chassis.
Fan	○	Monitors the fans.
Voltage	○	Monitors the voltage inside of the chassis.
Power supply	○	Monitors the power supply unit.
Door	×	Monitors chassis intrusion (open/close of the covers and doors on the chassis).
Software	○	Shows service, driver, and OS information.
Network	○	Shows network (LAN) information and monitors packets.
BIOS	○	Shows BIOS information.
Local polling	○	Monitors the values of an MIB item obtained by NEC ESMPRO Agent.
Storage	○	Monitors controllers and storage devices including hard disk drives.
File system	○	Shows the file system configuration and monitors the free space.
RAID system	×	Universal RAID Utility will monitor the RAID System.
Others*	○	Monitors OS stall using the Watch Dog Timer.
	○	Performs alert processing after an OS STOP error occurs.

○: Supported. △: Partially supported. ×: Unsupported.

*: Not displayed on the NEC ESMPRO Manager screen.

Tips

NEC ESMPRO Manager and NEC ESMPRO Agent are supplied with the server as standard. For how to install and use each software component, refer to the explanation of the component.

3.2 Firmware and Software Version Management

You can manage the version of firmware or software on the server and update them with an update package by using NEC ESMPRO Manager and ExpressUpdate Agent.

This feature automatically updates multiple packages without stopping the system by using NEC ESMPRO Manager.

4. Names and Functions of Parts

The names and the functions of the server's parts are as follows.

4.1 Front of the Server

Air cooling model

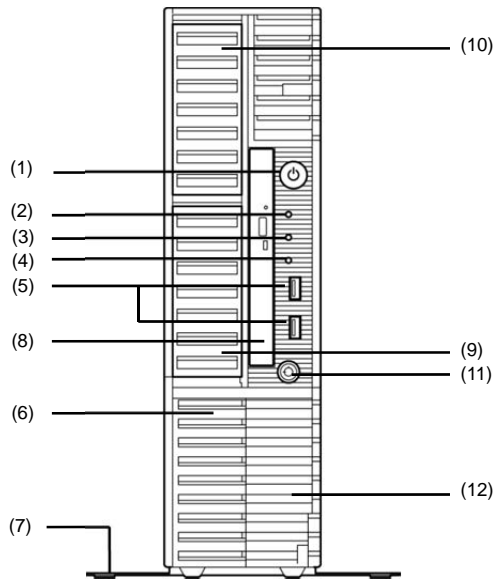

(1) POWER Switch

The switch to turn the server on and off. Press once to turn on the server. The LED lights green when it is on. Press it again to turn off the server. Hold down the switch for 4 seconds or more to forcibly turn off the server.

(3) POWER LED (green/amber)

After the power cord is connected, this LED lights amber during initialization of system. This LED lights green when the power is ON.

(3) Disk Access LED (green/amber)

This LED lights or flashes green when the internal hard disk drive or optical disk drive is being accessed.

The LED lights amber if a hard disk drive error occurs in the RAID system configurations except for an onboard RAID configuration using 3.5-inch hard disk drives

(4) STATUS LED (green/amber)

This LED indicates the server status. It lights green when the server is operating normally.

(5) USB Connectors (front)

These connectors are used to connect devices that support the USB interface.

Blue connector: for USB 3.0

Black connector: for USB 2.0

(6) Front Bezel

This cover protects the front part of the server.

(7) Stabilizer

To place the server vertically, install as shown in the above figure

(8) Optical Disk Drive

Either of the following drives can be installed.

- DVD-ROM drive
- DVD SuperMULTI drive

The drive provides the following: an eject button to eject the tray; an LED that indicates the drive access; and an eject hole to eject the tray forcibly

(9) 3.5-inch Expansion Bay 1

The bay which can accommodate 2.5-inch HDD cage (N8154-72F)

(10) 3.5-inch Expansion Bay 2

The bay which can accommodate 3.5-inch backup device.

(11) Key Slot

Bezel Lock Key can be inserted into Key Slot to lock Front Door when a 2.5-inch HDD cage is installed.

(12) Front Door

Open this door to handle the 2.5-inch hard disk drives.

Liquid cooling model

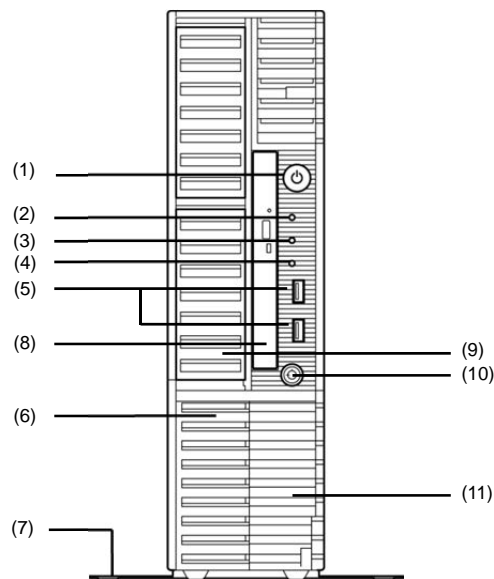

(1) POWER Switch

The switch to turn the server on and off. Press once to turn on the server. The LED lights green when it is on. Press it again to turn off the server. Hold down the switch for 4 seconds or more to forcibly turn off, the server.

(2) POWER LED (green/amber)

After the power cord is connected, this LED lights amber during initialization of system. This LED lights green when the power is ON.

(3) Disk Access LED (green/amber)

This LED lights or flashes green when the internal hard disk drive or optical disk drive is being accessed.

The LED lights amber if a hard disk drive error occurs in the RAID system configurations except for an onboard RAID configuration using 3.5-inch hard disk drives

(4) STATUS LED (green/amber)

This LED indicates the server status. It lights green when the server is operating normally.

(5) USB Connectors (front)

These connectors are used to connect devices that support the USB interface.

Blue connector: for USB 3.0

Black connector: for USB 2.0

(6) Front Bezel

This cover protects the front part of the server.

(7) Stabilizer

To place the server vertically, install as shown in the above figure

(8) Optical Disk Drive

Either of the following drives can be installed.

- DVD-ROM drive
- DVD SuperMULTI drive

The drive provides the following: an eject button to eject the tray; an LED that indicates hard disk drive access; and an eject hole to eject the tray forcibly.

(9) 3.5-inch Expansion Bay

The bay which can accommodate 3.5-inch device or extra HDD cage.

(10) Key Slot

Bezel Lock Key can be inserted into Key Slot to lock Front Door when a 2.5-inch HDD cage is installed.

(11) Front Door

Open this door to handle the 2.5-inch hard disk drives.

4.2 Rear View

Air cooling model, liquid cooling model

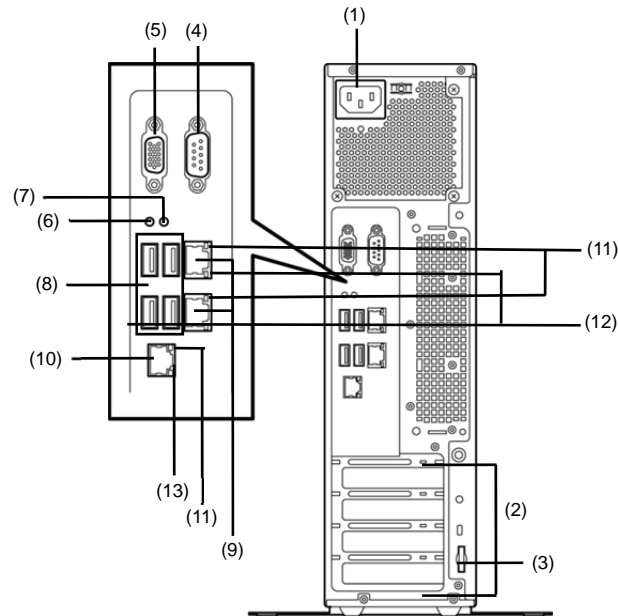

(1) AC Inlet

This socket is used to connect the power cord.

(2) PCI Slots

(3) Chassis Lock Tab

The lock protects internal components.

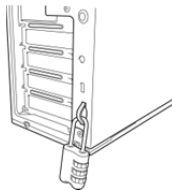

(4) Serial Port (COM A) Connector

This connector is used to connect devices that support a serial interface. Note that it is not possible to directly connect to a dedicated line. If the optional N8117-01A Additional RS232C Connector Kit is connected, the connector of N8117-01A is assigned as the serial port B.

(5) Display Connector

The connector to connect a display

(6) DUMP Switch

Press this switch to get a memory dump.

Do not press DUMP Switch usually. If DUMP Switch is pressed, the server stops.

(7) BMC RESET Switch

The switch to reset BMC of this server. Use the switch only when there is something wrong with EXPRESSSCOPE Engine 3 (BMC).

(8) USB Connectors

These connectors are used to connect devices that support the USB interface.

Blue connector: for USB 3.0

Black connector: for USB 2.0

(9) LAN Connectors

Supports 1000BASE-T interface.

If Shared BMC LAN feature is enabled in ROM Utility, LAN connector 1 can also be used as the management LAN connector. Sharing port is not recommended from the point of performance and security.

(10) Management LAN Connector

A LAN connector which supports 100BASE-TX. This port is used for connection with EXPRESSSCOPE Engine 3, and cannot be used as a data transmission port. This port cannot be used when Shared BMC LAN feature is used.

(11) LINK/ACT LED (green)

The LED indicates the access status of LAN

(12) SPEED LED (green/amber)

The LED indicates the transfer speed of LAN ports

(13) SPEED LED (green)

The LED indicates the transfer speed of the LAN port used for management

4.3 Internal View

<Air cooling model>

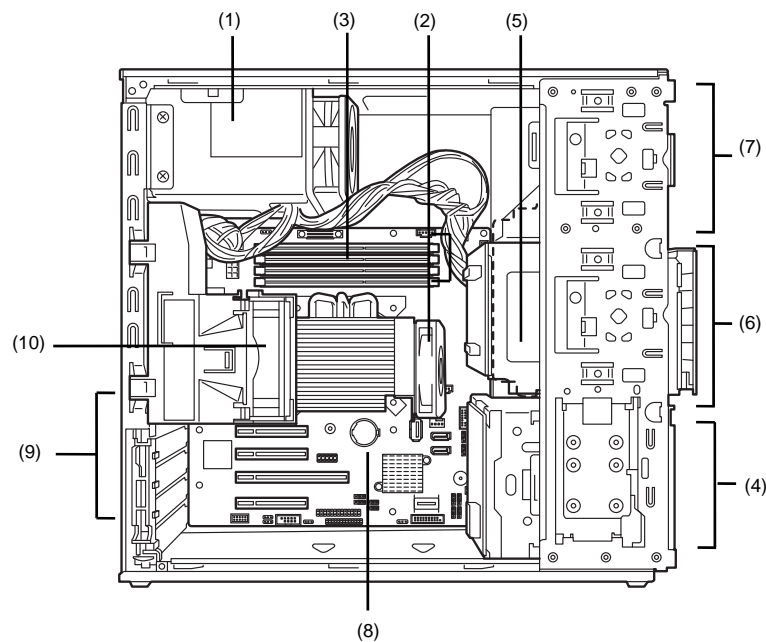

(1) Power Supply Unit

(2) Cooling Fan (CPU)

(3) DIMM Slots

(4) Hard Disk Drive Bay

Can be equipped with 3.5-inch or 2.5-inch hard disk drives.

The figure shows the view when 2.5-inch hard disk drives are installed.

(5) Optical Disk Drive

(6) 3.5-inch Expansion Bay 1

A bay that can accommodate an extra 2.5-inch HDD cage (N8154-72F)

(7) 3.5-inch Expansion Bay 2

A bay that can accommodate a 3.5-inch backup device

(8) Motherboard

(9) PCI Slot

(10) Cooling Fan (rear)

<Liquid cooling model>

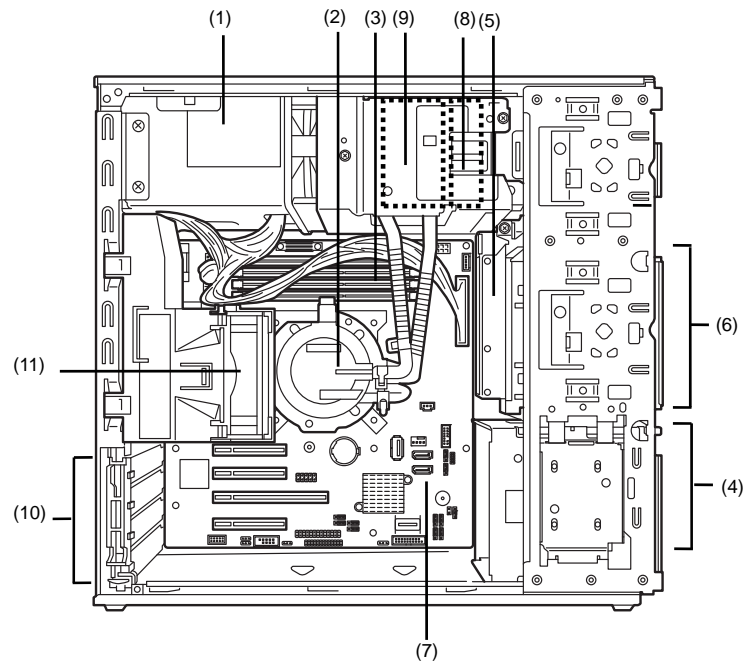

(1) Power Supply Unit

(2) Liquid Cooling Unit

(3) DIMM Slots

(4) Hard Disk Drive Bay

Can be equipped with 3.5-inch or 2.5-inch hard disk drives.

The figure shows the view when 2.5-inch hard disk drives are installed.

(5) Optical Disk Drive

(6) 3.5-inch Expansion Bay 1

A bay that can accommodate a 3.5-inch device or an extra 2.5-inch HDD cage

(7) Motherboard

(8) Cooling Fan (radiator)

(9) Radiator

(10) PCI Slots

(11) Cooling Fan (rear)

4.4 Motherboard

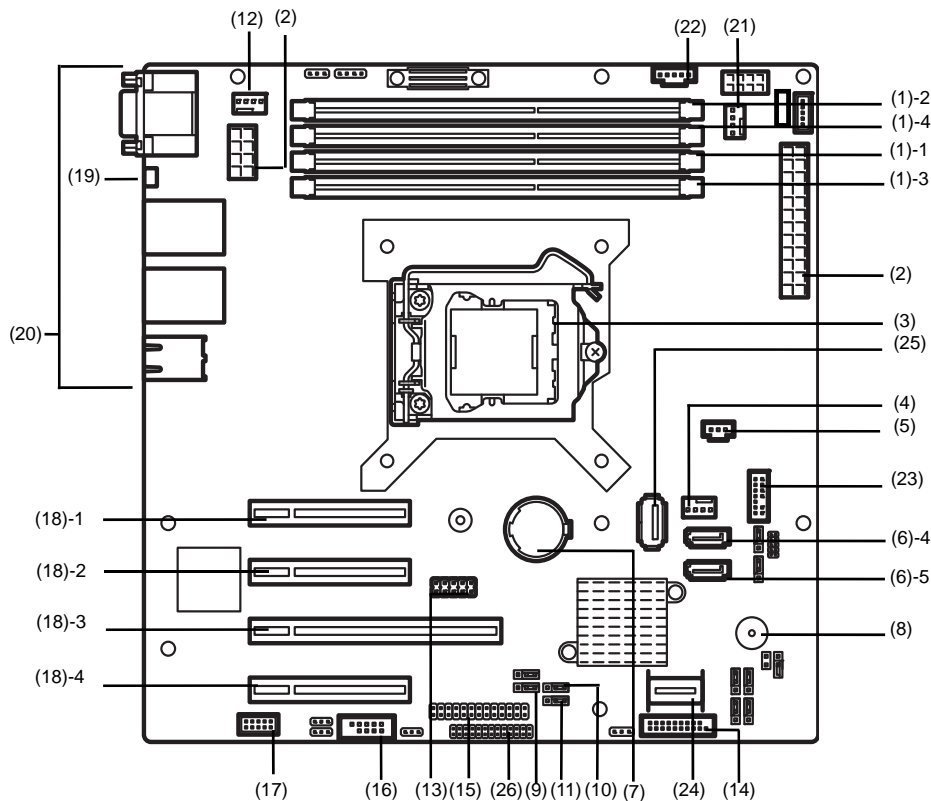

(1) DIMM Slots (the number after hyphen indicates DIMM number)

(2) Power Connector

(3) CPU Socket

(4) CPU Cooling Fan Connector (FAN1)

(5) RAID LED Cable Connector

(6) Serial ATA Connector (the number after hyphen indicates connector number)

(7) Lithium Battery

(8) Buzzer

(9) Clear CMOS Jumper

(10) RAID Configuration Jumper

(11) Clear Password Jumper

(12) Rear Fan Connector (FAN2)

(13) Internal Flash Memory connector

(14) USB Connector (for front)

(15) LED/SW Cable Connector

(16) Serial Port (COM B) Connector (for N8117-01A)

(17) SPI Flash Mezzanine Connector

EXPRESSSCOPE profile key (SPI memory) has been installed, where BIOS and BMC configuration data is stored. Move it when replacing MB to keep using the data.

(18) PCI Card Slots

(18)-1 PCI EXPRESS x1 (x8 connector)

(18)-2 PCI EXPRESS x1 (x8 connector)

(18)-3 PCI EXPRESS x16 (x16 connector)

(18)-4 PCI EXPRESS x4 (x8 connector)

(19) (Upper) BMC RESET Switch

(Lower) DUMP Switch (NMI)

(20) External Connector

(21) Radiator Fan Connector (FAN3)

(22) PMBus Connector

(23) TPM Mezzanine Connector

(24) Mini-SAS Connector

(25) USB Connector (for internal)

(26) HDD BP Connector

4.5 Status Indicators

This section explains the indication and meanings of the server LEDs.

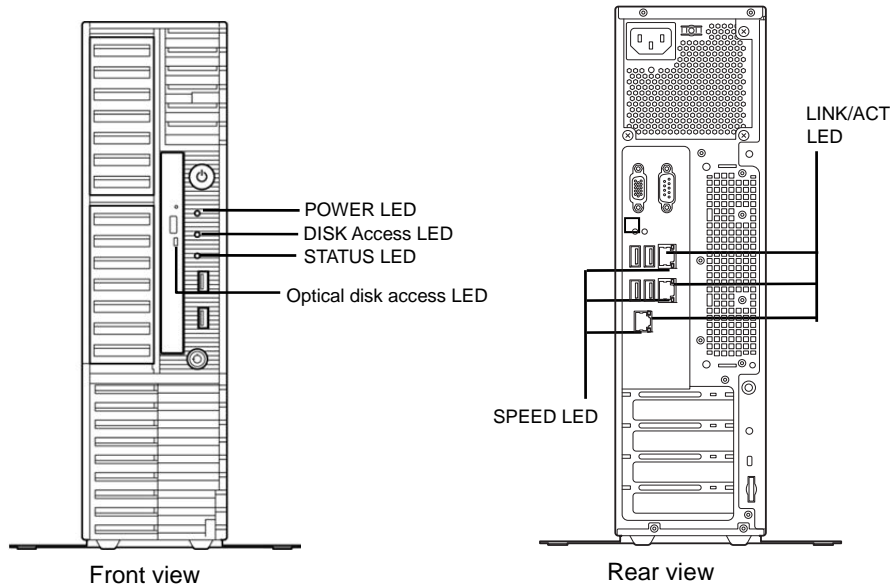

4.5.1 POWER LED ()

POWER LED indicates the power ON/OFF status of the server.

The following table lists POWER LED patterns.

POWER LED pattern	Description
On (green)	The server is normally powered on.
On (amber)	The power cord is plugged in and BMC is being initialized. The server can be powered on after the amber LED is unlit.
Off	The server is off-powered.

4.5.2 STATUS LED (▲)

STATUS LED lights green while hardware is operating normally. STATUS LED is off or lights/flashes amber if there is a hardware failure.

The following table lists STATUS LED patterns, their description and solution.

Tips

Refer to the system event log (SEL) by using NEC ESMPRO or the offline maintenance utility to view the cause of failure.

STATUS LED pattern	Description	Solution
On (green)	Normal state	–
Flashing (green)	Memory is in a degraded state	Find the device of the degraded state by using the BIOS setup utility <i>SETUP</i> , and replace it as soon as possible.
	Uncorrectable memory errors have often occurred.	
Off	The power is off.	Turn on the server.
	POST is in progress.	STATUS LED turns green after the POST process.
	Watchdog timer expired.	Turn the power off and then turn it on. If the POST screen displays any error message, take notes of the message, and contact your sales representative.
	An uncorrectable error in memory was detected.	
	A PCI bus error was detected.	
	Memory dump is being requested. DUMP Switch was pressed. Note It remains green when the dump is caused by software.	Wait until the memory dump is complete.
On (amber)	A temperature alarm was detected.	Check the internal cooling fan for dusts. Also check if the fan unit is properly connected.
	A voltage alarm was detected.	Contact your sales representative.
	A CPU temperature alarm was detected.	
	A CPU error was detected.	Turn the power off and then turn it on. If the POST screen displays any error message, take notes of the message, and contact your sales representative.
	SMI timeout was detected	Contact your sales representative.
	Sensor error was detected.	
Flashing (amber)	Failure of the power supply unit was detected	Contact your sales representative.
	A fan alarm was detected.	Check if the internal cooling fan cable is properly connected.
	A temperature warning was detected.	Check the internal cooling fan for dusts. Also check if the fan unit is properly connected.
	A voltage warning was detected	Contact your sales representative.
	An error was detected on either of the hard disk drives when a 2.5-inch HDD cage is installed and the RAID system is configured.	

4.5.3 Disk Access LED ()

DISK Access LED indicates the status of HDDs.

The following table lists DISK Access LED patterns.

DISK Access LED pattern	Hardware configuration	Description
On (green)/Flashing green	All	Hard disk drive or optical disk drive is being accessed.
On (amber)	A RAID system is configured by using an optional RAID controller. A RAID system is configured with 2.5-inch hard disk drives.	Hard disk drive is failing.
On (amber)	3.5-inch HDD cage and RAID controller N8103-172/173/174 are used.	The normal working after powering on or resetting.
Flashing green and amber alternately.	A RAID system is configured by using an optional RAID controller. A RAID system is configured with 2.5-inch hard disk drives.	Rebuild is in progress.
Off	All	Hard disk drive is halted.

4.5.4 Optical Disk Access LED

The LED lights/flashes when the media set on the optical disk drive is being accessed.

4.5.5 Disk LED

When 2.5-inch HDD cage is installed, each drive has its respective LED (Disk LED).

The following table lists DISK LED patterns.

Disk LED pattern	Description
On (green)/Flashing green	Hard disk drive is being accessed.
On (amber)	Hard disk drive is failing in RAID system.
Flashing green and amber alternately	Rebuild is in progress.
Off	Hard disk drive is halted.

4.5.6 LINK/ACT LED (□□1, □□2, □□M)

This LED indicates the status of the LAN port.

The following table lists LINK/ACT LED patterns.

LINK/ACT LED pattern	Description
On (green)	The server is connected with network correctly.
Flashing (green)	The server is accessing network.
Off	The server is disconnected from network.

4.5.7 SPEED LED (□□1, □□2, □□M)

This LED indicates which network interface is used.

- Two onboard LANs (□□1, □□2) support 1000BASE-T, 100BASE-TX, and 10BASE-TX.
- Management LAN (□□M) supports 100BASE-TX.

The following table lists LINK/ACT LED patterns.

SPEED LED pattern	Description
On (amber)	The port is operating with 1000BASE-T interface.
On (green)	The port is operating with 100BASE-TX interface.
Off	The port is operating with 10BASE-T interface.

Preparations

This chapter describes preparations for using this server.

1. Installing Internal Optional Devices

You can skip this section if you did not purchase any optional devices.

2. Installation and Connection

Place the server in a proper location and connect some cables following this section.

1. Installing Internal Optional Devices

This chapter describes the instructions for installing supported optional devices and precautions. If you did not purchase any optional device requiring installation, you can skip this section.

Important If you use the third party optional device to the server, and it causes failure, a charge for repairing must be paid even within the warranty period.

1.1 Safety Precautions

Be sure to observe the following precautions to install and remove optional devices properly and safely.

⚠ WARNING



Be sure to observe the following precautions to use the server safety. Failure to observe the precautions may cause death or serious injury. For details, refer to *Safety precautions in Precautions for Use*.

- Do not disassemble, repair, or modify the server.
- Do not remove the lithium, NiMH, or Li-ion battery.
- Do not handle the server while the power plug is inserted into the outlet.

⚠ CAUTION



Be sure to observe the following precautions to use of the server safely. Failure to observe the precautions may cause burns, injury, and property damage. For details, refer to *Safety precautions in Precautions for Use*.

- Do not attempt to lift the server by gripping the front bezel or vent holes cover.
- Make sure to complete installation.
- Do not get your fingers caught.
- High temperature.

1.2 Anti-static Measures

This product contains static-sensitive electronic components. Follow the measures below to avoid a failure caused by static electricity when installing or uninstalling any optional device.

- **Wearing Anti-static Wrist Strap or Anti-static Gloves**

Wear a wrist strap on your wrist and connect the wire to the chassis. If there is no wrist strap, touch an unpainted metal surface of the chassis connected to the ground to discharge static electricity from your body before touching the component. Touch the metal part occasionally to discharge the static electricity while working on the component.

- **Checking the Workplace**

- Work on an anti-static floor or concrete floor.
- If you work on a place where static electricity is likely to be generated (e.g. carpet), be sure to provide anti-static protection.

- **Using the Work Table**

Place the server on a mat with Electrostatic Discharge (ESD) protection.

- **Clothing**

- Do not wear wool or synthetic clothes.
- Wear anti-static shoes.
- Remove any kind of metal accessories such as a ring, bracelet or wrist watch.

- **Handling of Components**

- Keep the component in an anti-static bag until you install it to the server.
- Hold the component by the edges to avoid touching any terminals or mounting parts.
- Place the component in an anti-static bag when storing or moving them.

- **Handling of Cables**

When connecting a cable (e.g., LAN cable), static electricity may also be charged due to friction against the floor. Connecting the charged cable with an I/O device may cause damage to the devices in the system. It is recommended to use a product such as electrostatic discharge kit to eliminate the static charge before connecting the cable.

- **Installing and Uninstalling the Optional Device**

- To avoid electric hazard and malfunction, be sure to turn off the power switch of the server and unplug the power cord from the outlet before installing or uninstalling any optional device. If the device is hot-swappable, you do not need to turn off the power switch and unplug the power cord.
- The device contains static-sensitive electronic components. When installing or uninstalling the optional device, wear an anti-static wrist strap on your wrist to avoid a failure caused by the static electricity. To use the strap, connect the wire to the chassis

1.3 Overview of Installation and Removal

Install/remove components by using the following procedure.

1. Turn the server off.
See *Chapter 3 (6. Turning off the Server)*.
2. Disconnect the power cord from the outlet and the server.

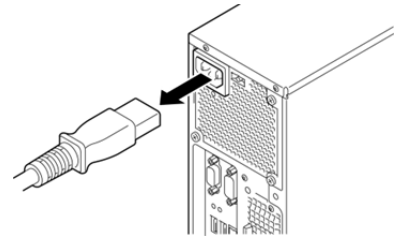

3. Disconnect all cables connected to the connector at the rear.
4. Remove the side cover.
See *Chapter 2 (1.4. Removing the Side Cover)*.
5. Remove the front bezel.
See *Chapter 2 (1.5 Removing the Front Bezel)*.
6. Depending on the components to be installed or removed, follow the procedure in order.
See *Chapter 2 (1.6 Internal Flash Memory to 1.14 Backup Devices)*.
7. Connect cables
See *Chapter 2 (1.15 Connecting Cables)*.
8. Attach the front bezel.
See *Chapter 2 (1.16 Attaching the Front Bezel)*.
9. Attach the side cover.
See *Chapter 2 (1.17 Installing the Side Cover)*.

Continue the setup with reference to *Chapter 2 (2.2 Connection)*.

1.4 Removing the Side Cover

Remove the side cover by using the following procedure.

1. See the steps 1 to 3 in *Chapter 2 (1.3 Overview of Installation and Removal)* for preparations.

2. Unlock the chassis, if necessary.

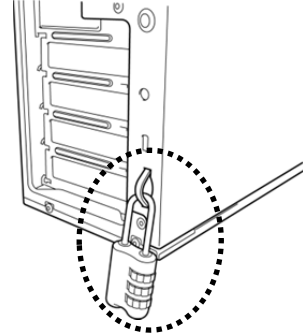

3. Lay the server slowly and gently so that the side cover faces upward and remove a screw.

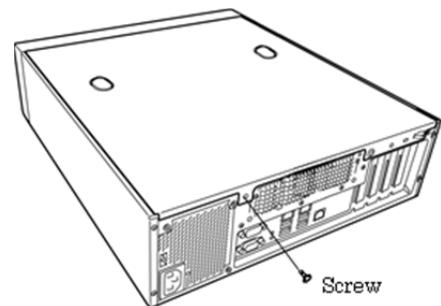

4. (1) While pressing the two release buttons, (2) slide the cover toward the rear of the server, (3) lift it in the direction shown by the arrow, and then (4) remove the cover in the direction shown by the arrow.

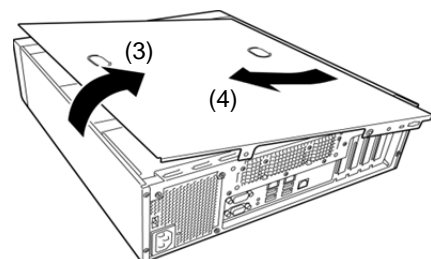
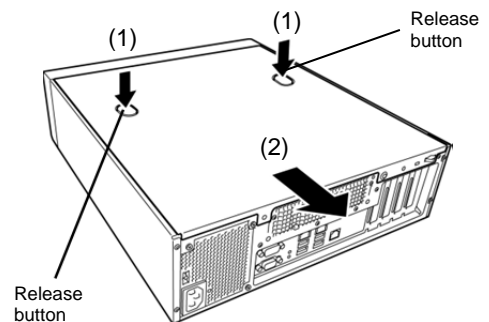

1.5 Removing the Front Bezel

Remove the front bezel by using the following procedure.

1. See the steps 1 to 3 in *Chapter 2 (1.3 Overview of Installation and Removal)* for preparations.
2. Remove the screw.

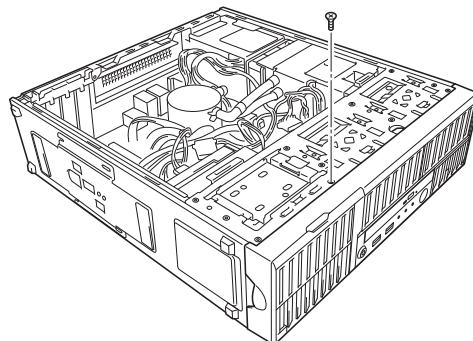

3. Place the server in the direction shown in the figure, and then pull the front bezel slightly toward the front until the tab can be released from the frame.

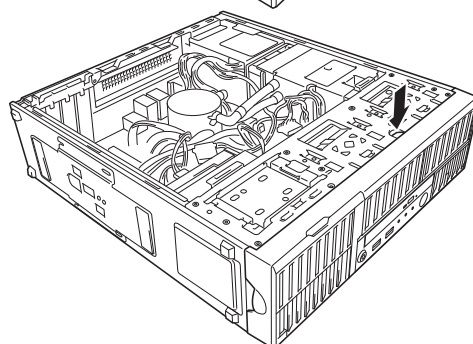

Important If you pull the front bezel forward too much, you will break the front bezel. Gently slide it to prevent damaging the equipment.

4. Slide the front bezel forward to release the hooks that engaged with the holes at the front of the server and take it off the server.

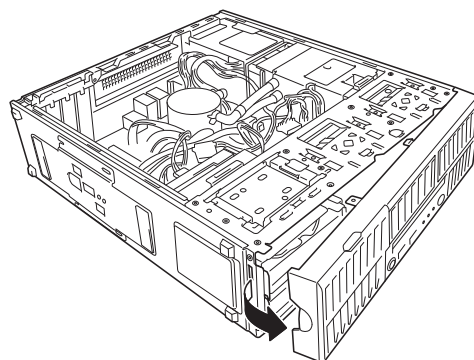

1.6 Internal Flash Memory

This section describes the procedure for installing the Internal Flash Memory.

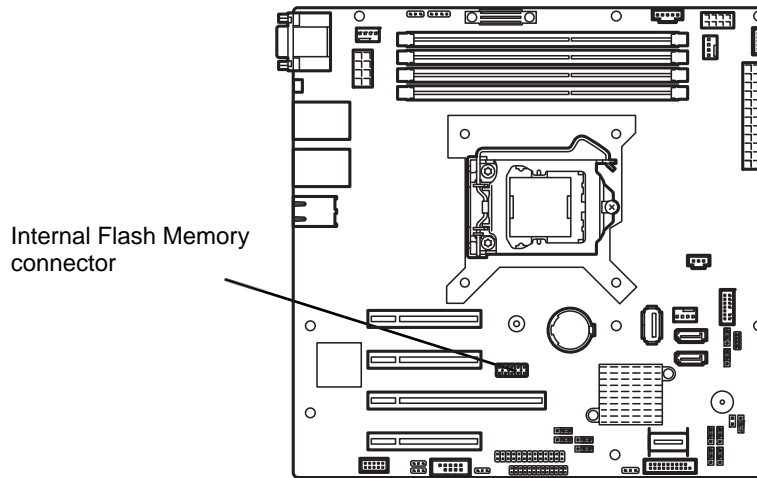

1.6.1 Installation

Install the Internal Flash Memory in the following procedure.

1. See the steps 1 to 5 in *Chapter 2 (1.3 Overview of Installation and Removal)* for preparations.
2. Attach the Internal Flash Memory and fix it with the screw that comes with the Internal Flash Memory Kit.

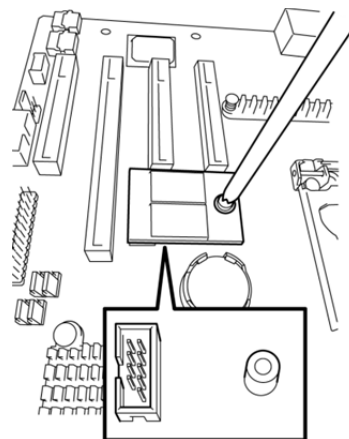

1.6.2 Removal

To remove the Internal Flash Memory, reverse the installation procedure.

1.7 TPM Kit

This section describes the procedure for installing optional TPM Kit.

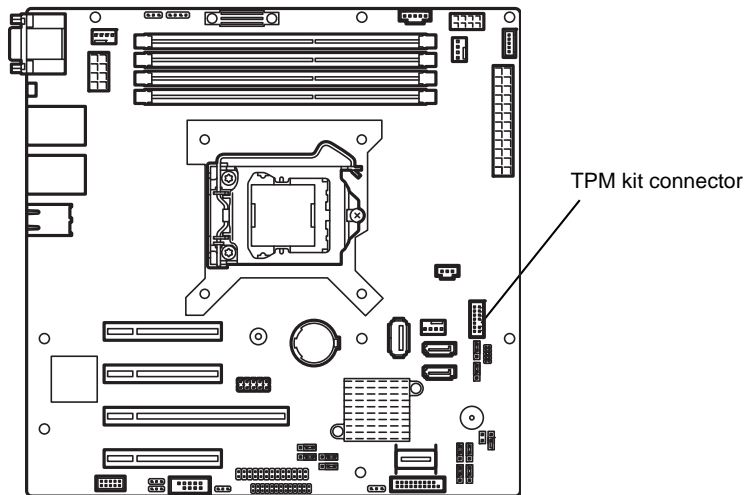

1.7.1 Installation

Install the TPM Kit in accordance with the following procedure.

Note The TPM kit once installed cannot be removed.

1. See the steps 1 to 5 in *Chapter 2 (1.3 Overview of Installation and Removal)* for preparations.
2. Pull the hard disk drive cage toward the front according to the steps in *Chapter 2 (1.12 HDD Cages)*.
(For a 3.5-inch hard disk drive cage, only pull the hard disk drive.)

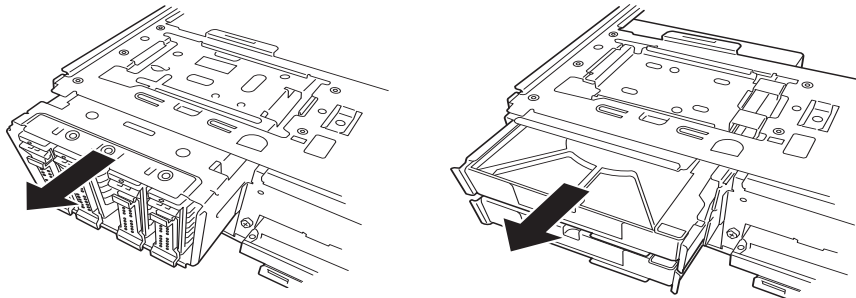

3. Install the TPM Kit and secure it by pushing the nylon rivet that comes with the TPM Kit.

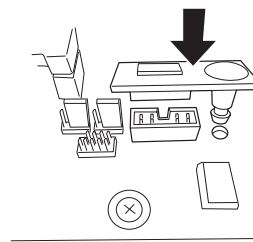

4. Re-assemble the parts that were removed in the steps 1 and 2.

1.8 DIMM

Install a Dual In-line Memory Module (DIMM) to a DIMM slot on the motherboard in the server. The motherboard provides four slots to install DIMMs.

Up to 32 GB (8 GB × 4) of memory can be installed.

Important

- Use only the DIMMs specified by NEC. Installing a DIMM from a third party may cause the server to fail. You will be charged to repair failures or damages caused by the use of such products even within the warranty period.
- Read through *Chapter 2 (1.2 Anti-static Measures)* beforehand.

Tips

As about 750 MB of memory is used for PCI resources, the available memory size may be less than the mounted memory size.

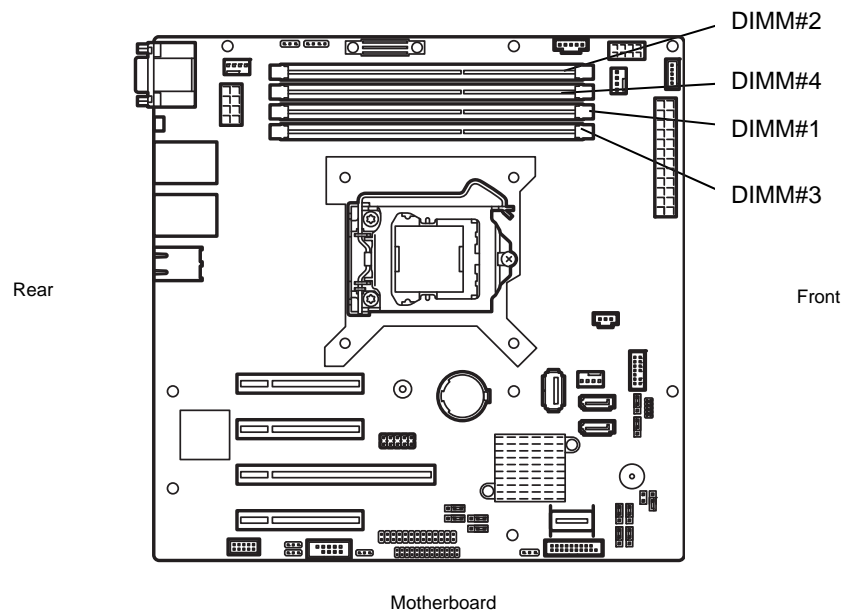

This server supports 2-way Interleave mode.

In 2-way interleaved memory system, the data transfer rate of the memory is twice that of a non-interleaved memory system.

1.8.1 Maximum supported memory size

The maximum available memory size on the server depends on the architecture (x86 architecture) and OS specs.

A list of maximum memory sizes

OS	The maximum memory size supported on each OS	The maximum memory size supported on the server
Windows Server 2008 Standard	4 GB	4 GB (using HW-DEP feature) * Default factory settings About 3.5 GB (not using HW-DEP feature) Note: When Execute Disable Bit (XD Bit) is set to Disabled in BIOS SETUP.
Windows Server 2008 R2 Standard (x64)	32 GB	32 GB
Windows Server 2008 Enterprise	64 GB	
Windows Server 2008 R2 Enterprise	2 TB	
Windows Server 2012 Standard Windows Server 2012 Datacenter	4 TB	
VMware ESXi 5.1	2 TB	32 GB Up to 1 TB of the main memory is available to each virtual machine.

1.8.2 Installation order

Install DIMMs one by one in order of increasing memory size into slots in the order of DIMM#1, DIMM#2, DIMM#3, and DIMM#4. If you want to run the server in 2Way Interleave mode, observe the following installation rules:

- Install DIMMs in pairs
- The two DIMMs installed together must be of the same specifications and memory size.
- Install the pairs as DIMM#1 and DIMM#2, or DIMM#3 and DIMM#4. The installation order between the pairs does not matter.

Installation examples

Example	2Way Interleave	DIMM#1	DIMM#2	DIMM#3	DIMM#4
1	Available	2 GB DIMM (Standard)	2 GB DIMM	Not installed	Not installed
2	Available	2 GB DIMM (Standard)	2 GB DIMM	2 GB DIMM	2 GB DIMM
3	Not available	2 GB DIMM (Standard)	2 GB DIMM	2 GB DIMM	Not installed
4	Not available	2 GB DIMM (Standard)	2 GB DIMM	Not installed	2 GB DIMM

1.8.3 Installation

Install a DIMM by using the following procedure.

1. See the steps 1 to 5 in *Chapter 2 (1.3 Overview of Installation and Removal)* for preparations.
2. Hold the server with both hands and slowly and gently lay it so that the left side faces upward.
3. Open both levers of the target DIMM slot outward.
4. Hold the DIMM vertically and push it into the slot.
When the DIMM is inserted correctly, the lever automatically closes.

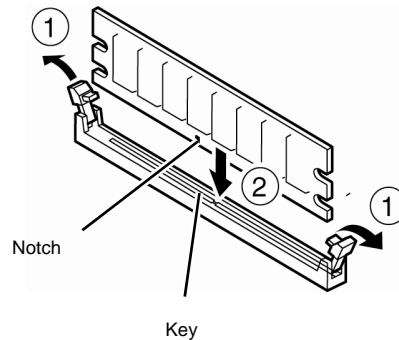

Important Do not apply too much pressure when you push a DIMM into the socket.

Note Align the notch on the DIMM with the key on the slot.

5. Firmly close the lever.
6. Continue to install or remove internal optional devices, mount and connect the server, and turn it on.
7. Confirm that no error messages are displayed in POST screen.
If any error messages are displayed, see *Chapter 3 (1. POST Error Message)* in "*Maintenance Guide*".
8. Run the BIOS Setup Utility, go to the **Advanced** menu, and check the **Memory Configuration**.
Confirm that the added DIMM has been recognized in the BIOS. Confirm that the applicable **DIMM Group Status** is set to "Normal". See *Chapter 2 (1. System BIOS)* in "*Maintenance Guide*".
9. Set the paging file size to the recommended value (Total memory size x 1.5) or more.
When using a Windows OS, see *Chapter 1 (6.1 Specifying Memory Dump Settings (Debug Information))* in "*Installation Guide (Windows)*".
For other OS, see the manual provided with the operating system or contact your sales representative.

1.3.4 Removal

Remove a DIMM in the following procedure.

Note

- When removing a defective DIMM, check error messages displayed at POST or NEC ESMPRO and check the DIMM slot where the defective DIMM is installed.
- At least one DIMM needs to be installed for the server to operate.

1. See the steps 1 to 5 in *Chapter 2 (1.3 Overview of Installation and Removal)* for preparations.
2. Open both levers of the target DIMM slot outward.
The DIMM is unlocked
3. Remove the DIMM by pulling it out from the slot in a straight direction.

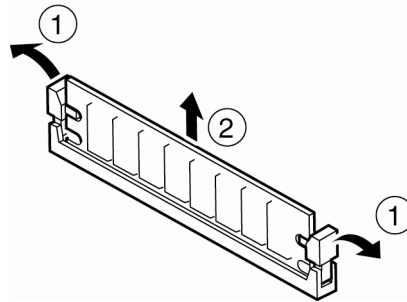

Important

Do not apply too much pressure when you pull a DIMM out from the socket.

4. Assemble the server.
5. Turn on the server and confirm that no error messages are displayed on POST. If any error message is displayed, see *Chapter 3 (1. POST Error Message)* in "Maintenance Guide".
6. If you replaced a broken DIMM, choose **Yes** in **Memory Configuration-Memory Retest** of the **Advanced** menu, and then choose **Save Changes and Exit** to restart.
7. Set the paging file size to the recommended value (Total memory size x 1.5) or more.
When using a Windows OS, see *Chapter 1 (6.1 Specifying Memory Dump Settings (Debug Information))* in "Installation Guide (Windows)".
For other OS, see the manual provided with the operating system or contact your sales representative.

1.9 Use of Internal Hard Disk Drives in the RAID System

This section describes how to use the hard disk drives installed in the HDD cage at the front of the server in the RAID system.

Important If you use hard disk drives in the RAID system or change the RAID level, initialize the hard disk drives. If the hard disk drive used in the RAID system contains valuable data, be sure to back up the hard disk drive before installing the RAID controller and configuring the RAID system.

Note In the RAID system, use hard disk drives that have the same specifications (capacity, rotational speed, and standard) for each disk array.

Tips Logical drives can be created even with only one physical device.

To build a RAID system, change the jumper switch on motherboard and backplane, as shown below.

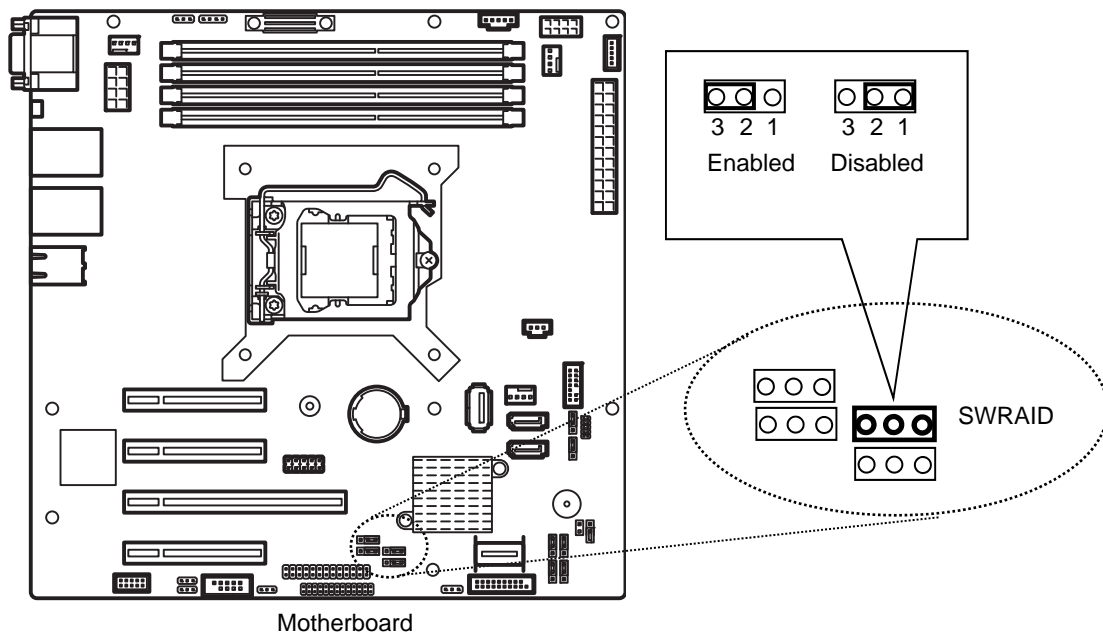

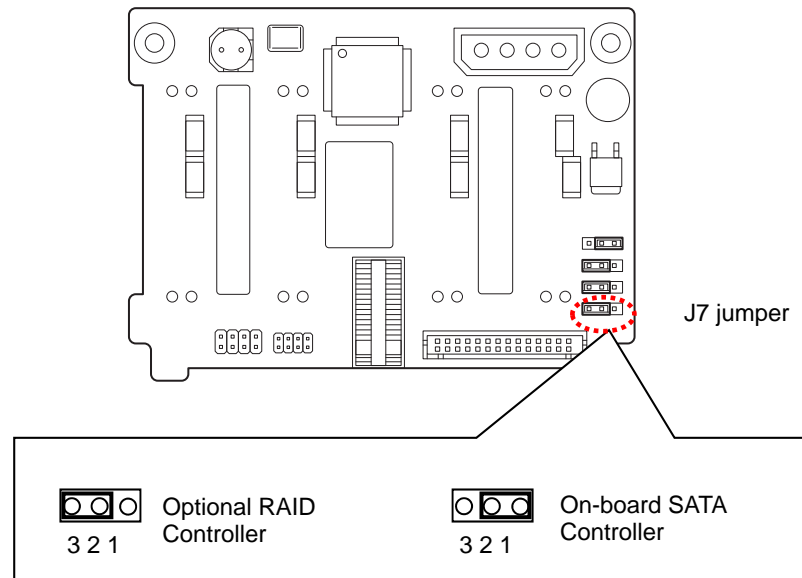

Backplane for 2.5-inch hard disk drives when a 2.5-inch HDD cage is installed

(a) **Using the on-board RAID controller (LSI Embedded MegaRAID™)**

Jumper on motherboard (SWRAID)

Change jumper setting to 2-3 (Enabled).

[Using 2.5-inch hard disk drive]

Backplane for 2.5-inch hard disk drive provided with 2.5-inch HDD cage (J7)

Change jumper setting to 1-2 (Onboard SATA controller).

[Using 3.5-inch hard disk drive]

No setting other than the jumper on the motherboard is required.

Configure the RAID system using EXPRESSBUILDER or LSI Software RAID Configuration Utility after changing the jumper.

For details, see *Chapter 2 (4. RAID System Configuration)* or *(5. Details of EXPRESSBUILDER)* in "Maintenance Guide".

(b) Using an optional RAID controller**Jumper on motherboard (SWRAID)**

Change jumper setting to 1-2 (Disabled).

Backplane for 2.5-inch hard disk drive provided with 2.5-inch HDD cage (J7)

Change jumper setting to 2-3 (Optional RAID Controller)

Note

When installing an optional RAID Controller, start the BIOS Setup utility, select **PCI Configuration** from the **Advanced** menu, and then make sure that the parameter of **PCI Slot xx ROM** (xx is PCI slot number) is set to **Enabled**.

Important

Do not change the mode to hibernate when building a RAID system.

(c) Installation

For the instruction of installing the optional RAID Controller, see *Chapter 2 (1.11 PCI Card)*.

Important

When connecting a RAID controller, set the boot priority to 8th or higher in the Boot menu of the BIOS Setup utility. If the setting is 9th or lower, the configuration menu for RAID controllers cannot be launched.

(d) Removal

To remove the optional RAID controller, reverse the installation procedure.

If you intend to use with the card removed, be sure to attach the blank cover attached to the riser card.

1.9.1 Notes on setting up a RAID System

Note the following points when setting up a RAID system.

- The number of hard disk drives required varies in each RAID level.
- If an on-board RAID controller or optional RAID controller (N8103-171/172) is used, the RAID system cannot be built in RAID5/RAID6.

RAID level	The minimum number of hard disk drives required to set up a RAID system	
	On-board RAID Controller or N8103-171/172	N8103-173/174/168
RAID 0	1	1
RAID 1	2	2
RAID 5		3
RAID 6		3
RAID 10	4	4
RAID 50		6
RAID 60		6

- Use SAS/SATA hard disk drives or SSDs that have the same capacity and rotational speed.
- RAID 10 using a hard disk drive of 2 TB or more cannot be supported if an on-board RAID controller is used.
- When installing an OS in your RAID system, you can easily complete the setup process, including RAID configuration and OS installation, by using EXPRESSBUILDER.
- If you are installing the OS manually, use the RAID system configuration utility. The utility can be run during POST which starts immediately after the server is turned on. For details, see *Chapter 2 (4. RAID System Configuration)* in "*Maintenance Guide*" or the manual supplied with the optional RAID controller.

Important

- Do not change the RAID system mode to hibernate.
- A mix of SAS and SATA drives cannot be used within the RAID system.

HDD slot numbering

<3.5-inch HDD cage>

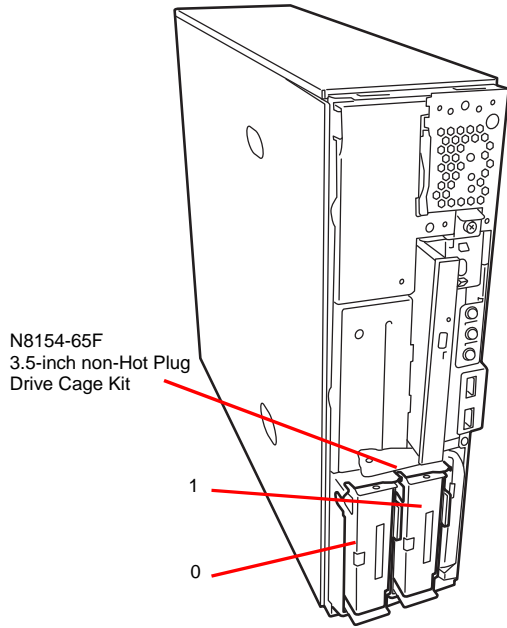

<2.5-inch HDD cage>

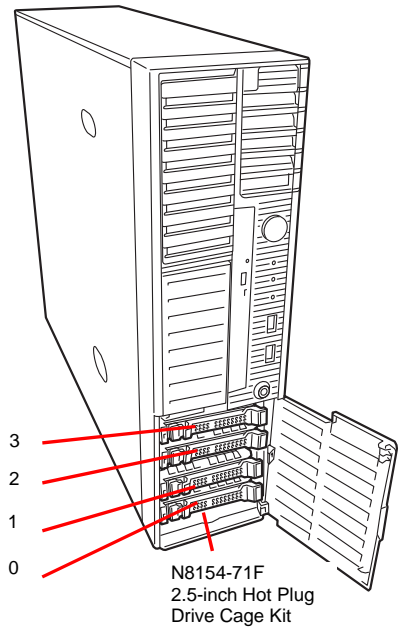

<3.5-inch HDD cage and extra 2.5-inch HDD cage>

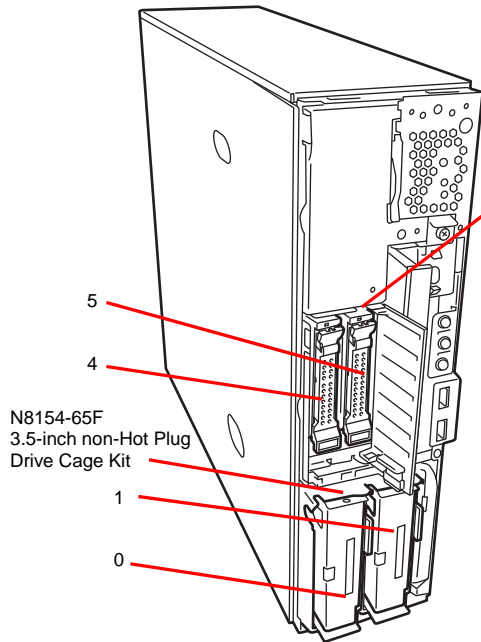

<2.5-inch HDD cage and extra 2.5-inch HDD cage>

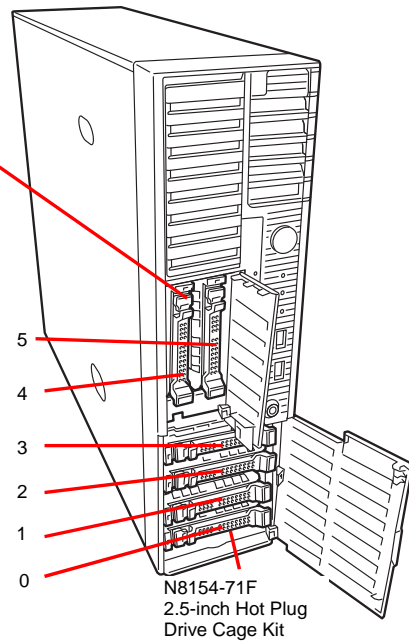

1.10 Extra Battery for RAID Controller

The optional extra battery is used in order to avoid data loss caused by accidents during a write-back operation. The model of the extra battery to be used depends on a RAID controller.

- For N8103-172/173/174, use N8103-155 extra battery
- For N8103-168, use flash backup unit that comes with N8103-168 RAID controller

1.10.1 Handling precautions

Observe the following precautions to use the extra battery.

- Use the extra battery that supports the RAID controller used.
- The extra battery is a very delicate electronic device. Before installation, touch the metal frame part of the server to discharge the static electricity from your body.
- Do not drop or bump the backup battery.
- For recycling and disposing the backup battery, refer to the manual that comes with it.

1.10.2 Installing N8103-155 extra battery

Install an extra battery in the server by using the following procedure.

Note

Read through the manual supplied with the RAID controller before installation.

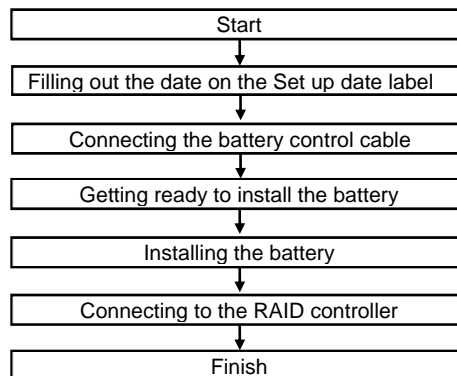

Filling out the date on the Set up date label

Write down the installation date (year and month) on the Set up date label supplied with the extra battery. Attach the label on the battery cover or somewhere easy to find on the server.

Fill out the *Set up date* label supplied with the battery

Set up Date
Y 13 .M 06

← Write the date.(The last two digits)
Example: Y 13. M 06

Important The battery life is about two years. If it has been used for two years or more, replace it soon with a new battery pack, referring to the manual for the extra battery.

Connecting the battery control cable

To connect the battery control cable into the battery pack, see the following figure. Check the form of the connector and connect the cable straight into the connector.

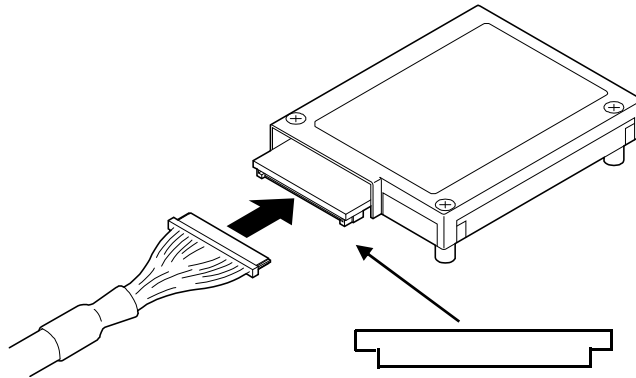

The upper portion is wider than that of lower portion.

Important When installing or removing the extra battery, pay attention not to apply excessive pressure on the part of the battery cover marked in the image below.

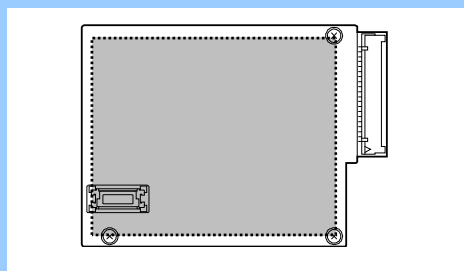

Getting ready to install the battery

1. See *Chapter 2 (1.3 Overview of Installation and Removal)* for preparations.
2. To remove the side cover and the front bezel, see *Chapter 2 (1.4 Removing the Side Cover and 1.5 Removing the Front Bezel)*.

Installing the battery pack

1. Remove one screw from the front panel bracket.

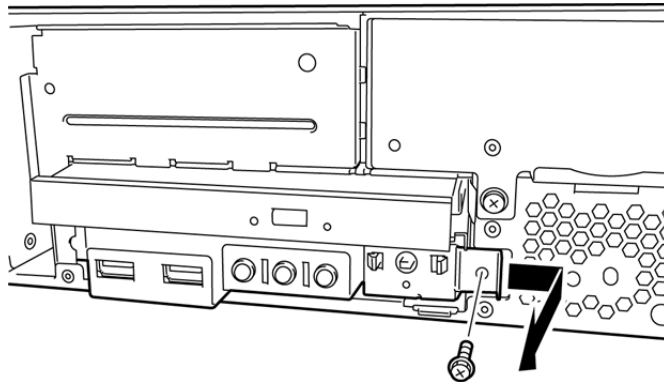

2. Slide the front panel bracket slightly toward the right, and then pull the bracket toward the front to remove it.

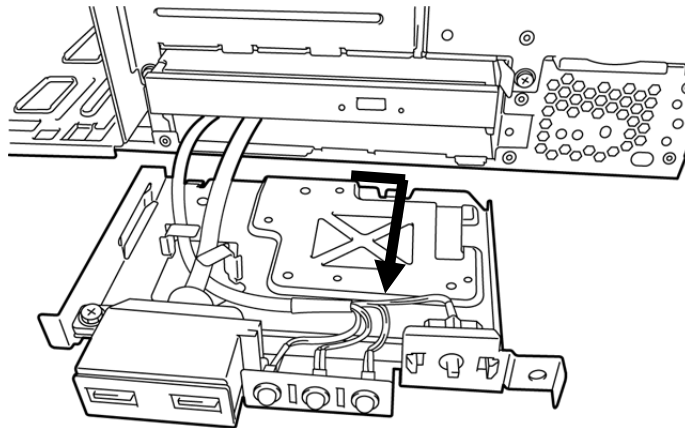

Important Be careful that the cable does not come out from the connector when pulling the front panel bracket.

3. Mount the battery on the bracket, and then secure with three screws from the reverse side, and then fix battery cable.

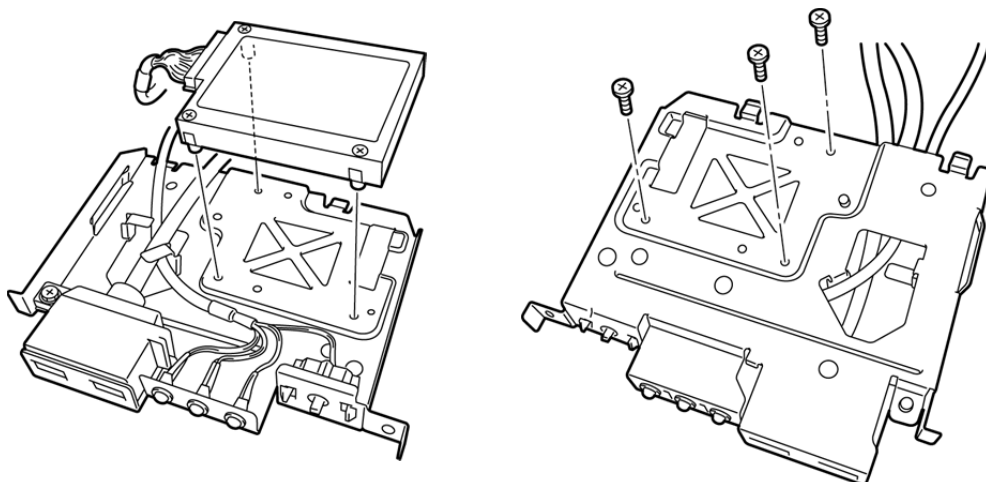

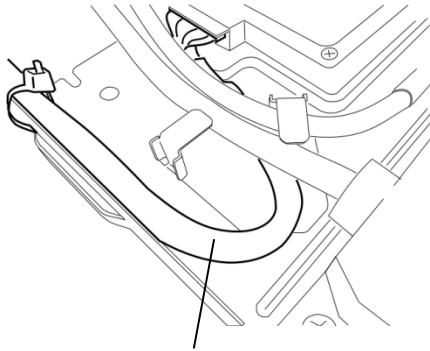

Arrange the battery cable as shown in the figure.

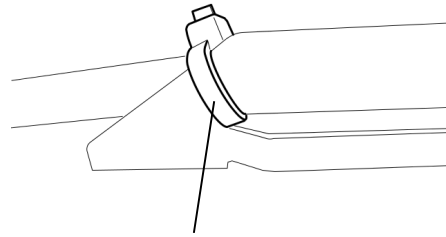

With cable tie attached, fixed the battery cable to the bracket as shown in the figure.

4. Draw the cable into the chassis and mount the front panel bracket on the server chassis in the reverse order of the removal procedure.

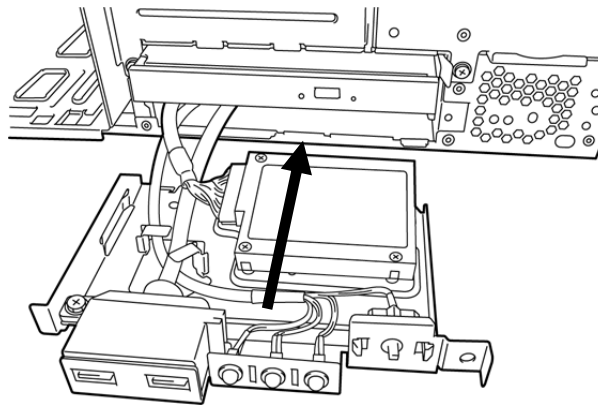

Connecting to a RAID Controller

1. Connect another connector of the battery control cable to the connector on the RAID controller. Check the form of the connector and connect the cable straight into the connector. Be careful not to press it in at an angle when connecting.

Position of the connector

Connect the cable to the connector shown in the figure below.

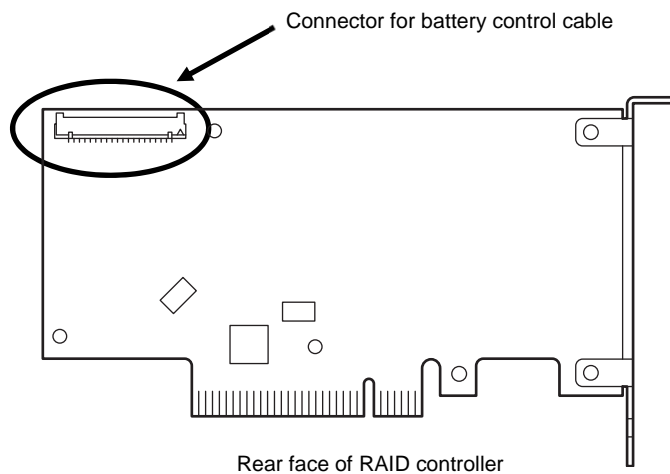

2. Install the RAID controller into the PCI slot #4 and fix it in place. Be careful not to disconnect the battery control cable.

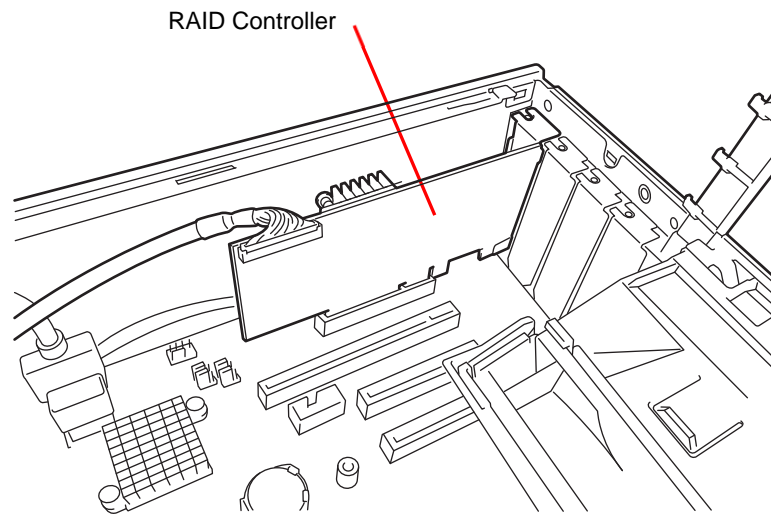

3. Connect the cables and components that you removed.

1.10.3 Removal

To remove the extra battery for the RAID controller, reverse the installation procedure.

1.10.4 Installing the flash backup unit that comes with N8103-168

Install the flash backup unit that comes with N8103-168 RAID Controller the by using the following procedure.

Note

Read through the manual supplied with the RAID controller before installation.

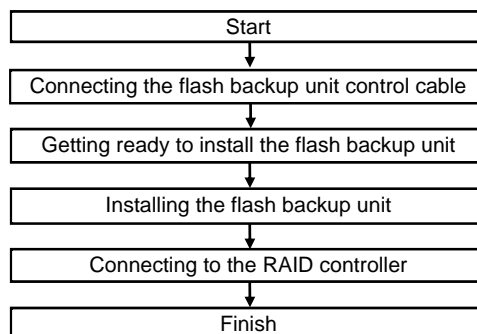

Connecting the flash backup unit control cable

To connect the flash backup unit control cable into the flash backup unit, see the following figure. Check the form of the connector and connect the cable straight into the connector.

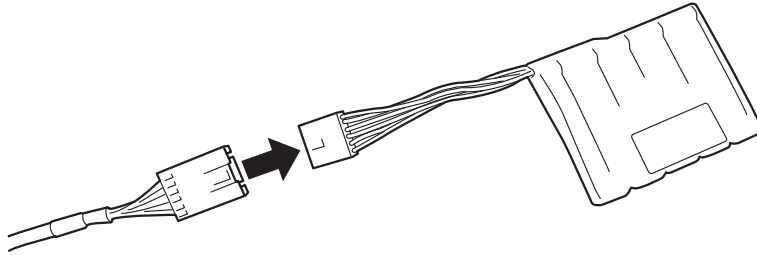

Getting ready to install the flash backup unit

1. See *Chapter 2 (1.3 Overview of Installation and Removal)* for preparations.
2. To remove the side cover and the front bezel, see *Chapter 2 (1.4 Removing the Side Cover and 1.5 Removing the Front Bezel)*.

Installing the flash backup unit

1. Remove one screw from the front panel bracket.

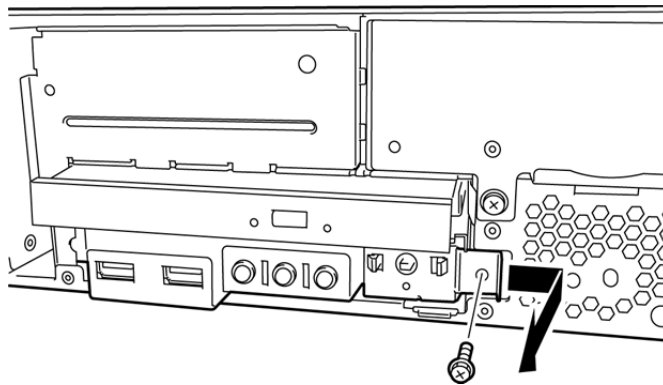

2. Slide the front panel bracket slightly toward the right, and then pull the bracket toward the front to remove it.

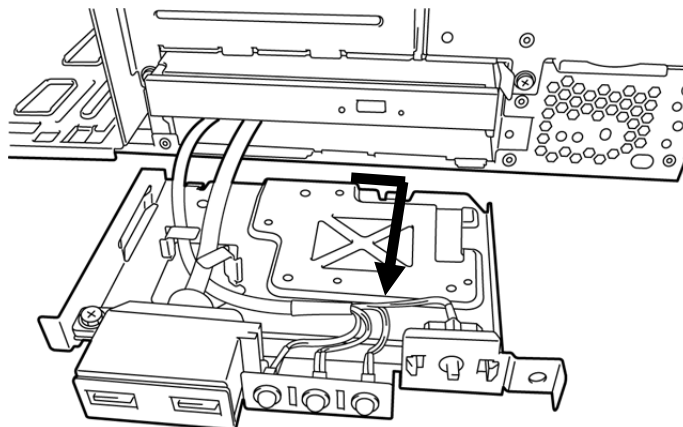

Important Be careful that the cable does not come out from the connector when pulling the front panel bracket.

3. Mount the flash backup unit on the RAID controller by using the anchoring bracket that comes with the RAID controller and secure it by using one screw.

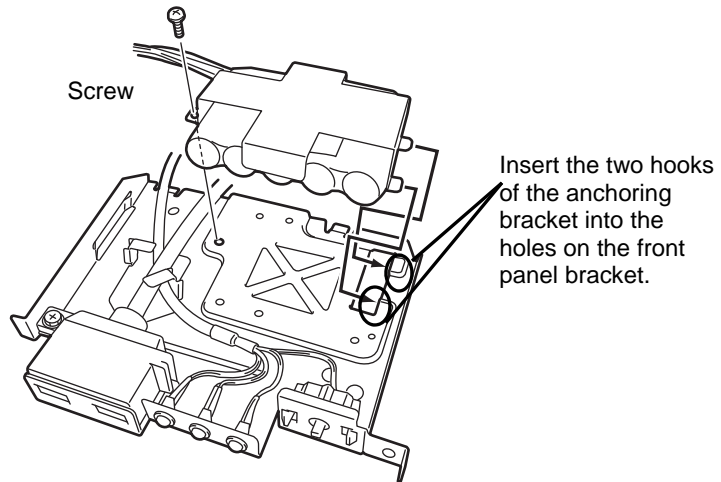

4. Draw the cable into the chassis and mount the front panel bracket on the server chassis in the reverse order of the removal procedure.

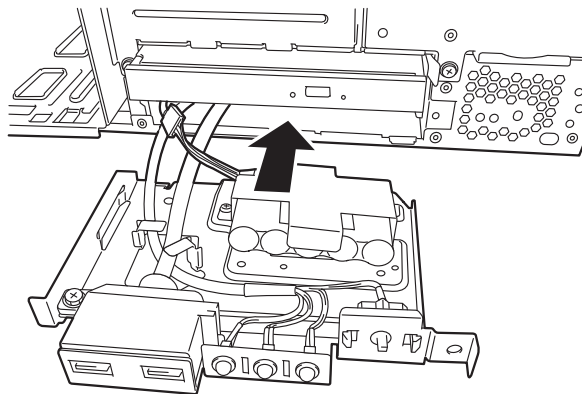

Connecting to a RAID Controller

1. Connect another connector of the flash backup unit control cable to the connector on the RAID controller. Check the marker of the connector and connect the cable straight into the connector. Be careful not to press it in at an angle when connecting.

Position of the connector

Connect the cable to the connector shown in the figure below.

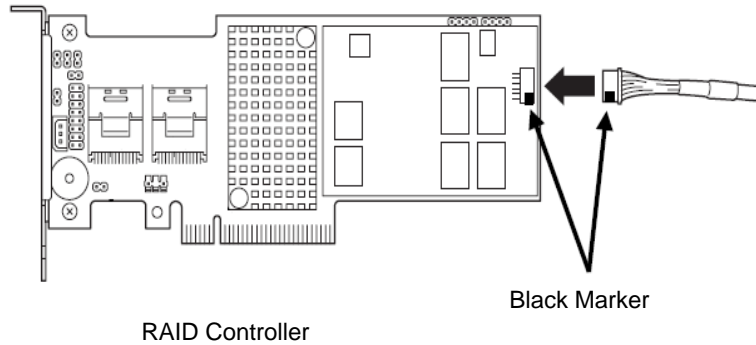

2. Install the RAID controller into the PCI slot #4 and fix it in place. Be careful not to disconnect the cable.

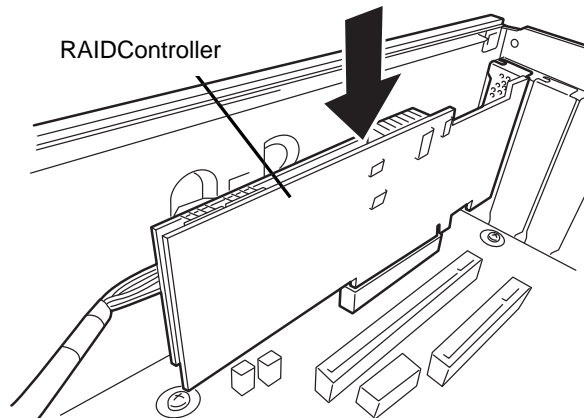

3. Connect the cables and components that you removed.

1.10.5 Removal

To remove the flash backup unit, reverse the installation procedure.

1.1.1 PCI Card

This server provides four slots where PCI cards can be installed.

Important

- Avoid static electricity to work with the procedure below. For details, see Chapter 2 (1.2 Anti-static Measures).
- When installing PCI cards, see *Chapter 2 (1.11.2 List of optional devices and installation slots)* to prevent mistaking slot numbers.
- Configure the Option ROM in [PCI Configuration] according to the application of the installed PCI card. For the configuration instructions, see *Chapter 2 (1. System BIOS) in "Maintenance Guide"*.
Disabling the deployment of Option ROM can not only prevent memory consumption but also shorten the startup time.

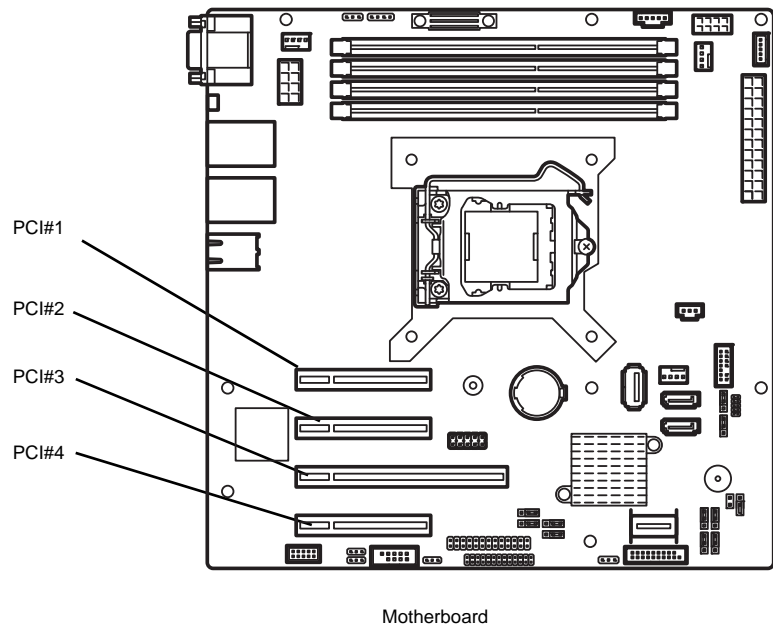

1.11.1 Notes

Read the following notes when installing or removing a PCI card.

- Do not touch the terminals of cards and the leads of electronic components with your bare hand. Fingerprints and dust left on them cause the server to malfunction due to a connection failure or damage to the leads.
- The search order for PCI bus slot on boot is as follows.
Slot 3 → Slot 4 → Slot 1 → Slot 2
- The PCI devices of the same type (including onboard PCI device) may be recognized in different order from that described above, depending on OS or RAID System BIOS utility. Check the slot location of PCI device by PCI bus number, device number and function number shown in the table below.

PCI device	PCI bus number	Device number	Function number
Onboard NIC1	3h	0	0
Onboard NIC2	3h	0	1
Slot 1	41h	0	×
Slot 2	59h	0	×
Slot 3	1h	0	×
Slot 4	21h	0	0

- Set **Disabled** for the optional ROM of a LAN device not to be booted by using the BIOS Setup utility.
- If an additional bootable PCI card (such as a RAID Controller, SAS controller, or LAN card) is installed, the boot priority may change. After the installation, set the boot priority in the **Boot** menu of the BIOS Setup utility.
- If a bootable device such as a PCI card or USB device is added, the boot order may change. In the BIOS Setup utility, select **Hard Drive BBS Priorities** from the **Boot** menu, and then specify a higher priority for the boot device.
Boot → **Hard Drive BBS Priorities** → Check the display
If the boot device is an HDD under an optional RAID Controller, the display is (Bus xx Dev 00) PCI RAID Adapter.
Note that the value for xx changes depending on the PCI slot where a RAID Controller is installed.

1.11.2 List of optional devices and installation slots

Model name	Product name	PCI Express				Remark
		2.0		3.0		
		PCI#1	PCI#2	PCI#3	PCI#4	
		X1 lane	X1 lane	x16 lane	x4 lane	
		Low Profile				
PCI slot performance ^{*1}						
PCI slot size	Low Profile					
PCI board socket type ^{*1}	x8	x8	x16	x8		
Size of mountable board	168 mm or less					
N8103-142	SAS controller (card performance: PCI Express 2.0 (x8))	–	○	○	○	For connecting external devices. Cannot be connected to internal hard disk drives.
N8103-171	RAID controller (128 MB, RAID 0/1) (card performance: PCI Express 2.0 (x8))	–	–	–	○	For connecting internal hard disk drives Cannot be connected to an extra battery.
N8103-172	RAID controller (512 MB, RAID 0/1) (card performance: PCI EXPRESS 3.0 (x8))	–	–	–	○	For connecting internal hard disk drives
N8103-173 ^{*3}	RAID controller (512 MB, RAID 0/1/5/6) (card performance: PCI Express 3.0 (x8))	–	–	–	○	Can be connected to an extra battery (N8103-155)
N8103-174	RAID controller (1 GB, RAID 0/1/5/6) (card performance: PCI Express 3.0 (x8))	–	–	–	○	Cannot be used when a 3.5-inch HDD cage is installed.
N8103-168 ^{*3}	RAID controller (1 GB, RAID 0/1/5/6) (card performance: PCI Express 3.0 (x8))	–	–	–	○	For connecting internal hard disk drives The RAID cache can be backed up by using the flash backup unit that comes with N8103-168. Separately, RAID controller installation kit(K410-328(00)) is necessary
N8104-138	1000BASE-T connection board (1ch) (card performance: PCI Express 2.0 (x1))	○	○	○	○	For additional LAN Card type: PCI Express 2.0(x4)
N8104-132	1000BASE-T connection board (2ch) (card performance: PCI Express 2.0 (x1))	○	○	○	○	For additional LAN Card type: PCI Express 2.0(x4)
N8104-133	1000BASE-T connection board (4ch) (card performance: PCI Express 2.0 (x4))	○	○	○	○	For additional LAN.
N8117-01A	Expansion RS-232C connector kit ^{*2}	○	○	○	○	For additional serial port (RS-232C)

○ Can be installed – Cannot be installed

*1 Lane: Indicates the transfer performance (transfer bandwidth).
<e.g.> 1 lane = 2.5 Gbps (unidirectional), 4 lanes = 10 Gbps (unidirectional)

Socket: Indicates the connector size. A card up to the number of sockets can be connected.
<e.g.> x4 socket = x1 card, x4 card can be installed. x8 card cannot be installed.

*2 The N8117-01A expansion RS-232C connector kit contains two types of cables. This server uses the RS-232C cable (B).

*3 3.5-inch HDD is not supported.

- The depth of mountable boards is up to 168 mm (MD2).
- For details of functions of each card, refer to the technical guide.
- The card performance described in the parentheses after the Product name indicates the maximum operation performance of the card.
- Even if you use PCI cards of a higher performance than the PCI slot, the operation of the device will be that of the PCI slot.

About the standard network

You can use functional equivalents of AFT/SFT/ALB teaming and bonding with the standard network and the following LAN cards:

N8104-132, N8104-133 and N8104-138

1.11.3 Installation

Install a PCI card to connect to a PCI slot by using the following procedure.

1. Before installation, make sure the switch or jumper settings on the PCI card are proper according to the instruction manual supplied with the card if necessary.
2. See *Chapter 2 (1.3 Overview of Installation and Removal)* for preparations.
3. To remove the side cover, see *Chapter 2 (1.4 Removing the Side Cover)*.
4. Open the PCI slot retention latch.

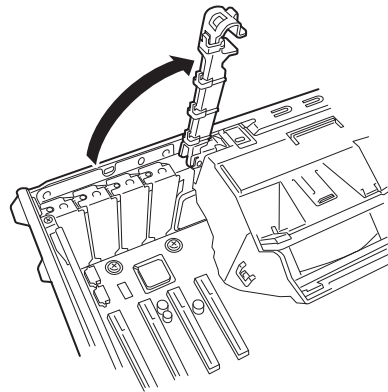

5. Remove the blank cover aligned with the slot where you will install a card.

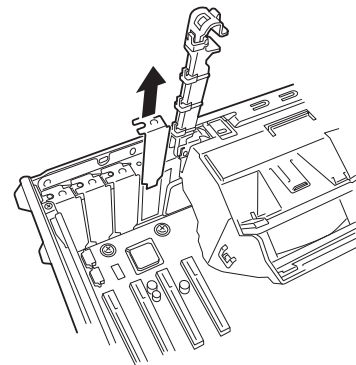

Important | Keep the removed blank cover for future use.

6. Face the component side of the card toward the bottom of the server. When the rear panel of the card is firmly engaged with the spring, firmly press the card into the slot so that the component parts of the card securely connect to the slot.

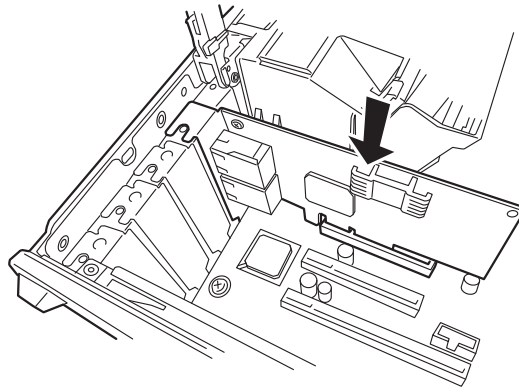

Important If you have trouble installing the card, remove the card once and try again. If you apply excessive pressure on the card, there is a risk of breaking the card.

7. Close the PCI slot retention latch.
When it locks, you hear a clicking sound.

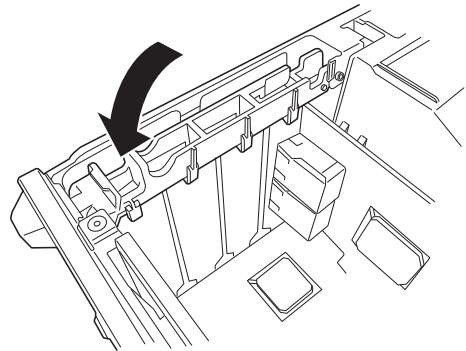

8. Assemble the server.
9. Turn on the server and confirm that no error messages are displayed in POST.
If an error message is displayed, take notes on the message and ask your sales representative.

1.11.4 Configuration after installing

Depending on the type of card installed, you need to use a utility, such as the BIOS setup utility, a setup utility provided with the card, following installation to modify server settings.

Follow the instructions in the manual provided with the card to specify the correct settings.

After turning the server power on, the PCI bus numbers are scanned in ascending order. If the option ROM installed in the card contains a BIOS utility, the startup message (banner) is displayed in ascending order of the PCI bus numbers.

1.11.5 Removal

Remove a PCI card connected to a PCI slot by using the following procedure.

1. See *Chapter 2 (1.3 Overview of Installation and Removal)* for preparations.
2. To remove the side cover, see *Chapter 2 (1.4 Removing the Side Cover)*.
3. See installation step 4 to open the PCI slot retention.
4. Remove the card.
5. Attach the blank cover, and see installation step 7 to close the PCI slot retention.
6. Assemble the server.
7. Turn on the server and confirm that no error messages are displayed in POST.
If an error message is displayed, take notes on the message and ask your sales representative.

1.11.6 Installing the N8117-01A extra RS-232C connector kit

Install a PCI card to connect to the PCI slot by using the following procedure. For details, refer to the instruction manual supplied with the connector kit.

The component parts for N8117-01A are as follows:

Item no.	Item name	Specification	Amount	Remarks
<1>	RS-232C connector Kit User's Guide	856-125671-002	1	
<2>	RS-232C cable (A)	804-063264-020	1	Not available for this server
<3>	RS-232C cable (B)	804-062746-820	1	
<4>	PCI bracket (1)	243-112122-001	1	Preinstalled to cable
<5>	PCI bracket (2)	243-112122-002	1	For full height PCI

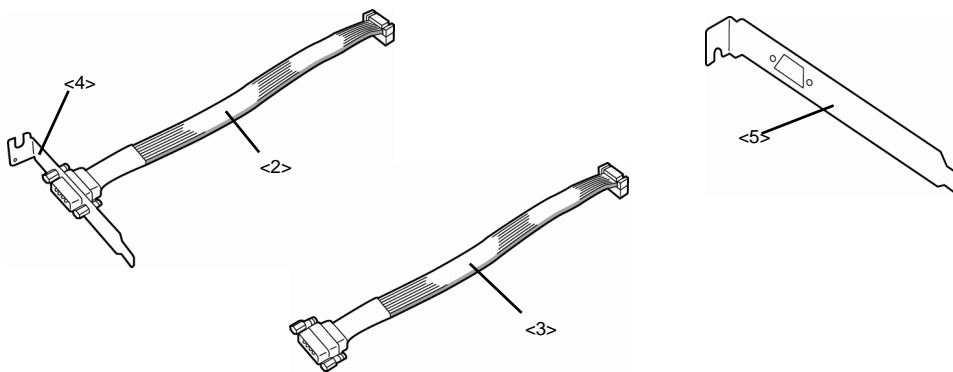

This product uses a combination of items <3> and <4>.

Follow the procedure below to install the kit.

1. See *Chapter 2 (1.3 Overview of Installation and Removal)* for preparations.
2. To remove the side cover, see *Chapter 2 (1.4 Removing the Side Cover)*.
3. Assemble <3> RS-232C cable (B) and <4> PCI bracket (1).
4. To open the PCI slot retention latch, see *Chapter 2 (1.11.3 Installation)*.
5. Remove the expansion blank cover aligned with the slot where you will install a card.

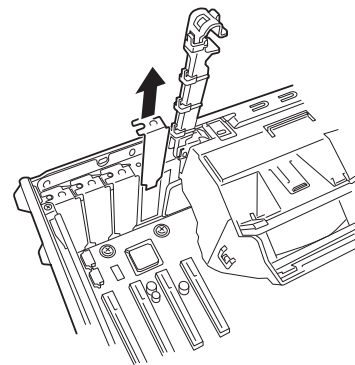

Important Keep the removed blank cover for future use.

6. Make sure that you are properly inserting the bracket edge into the frame guide, and attach it securely.

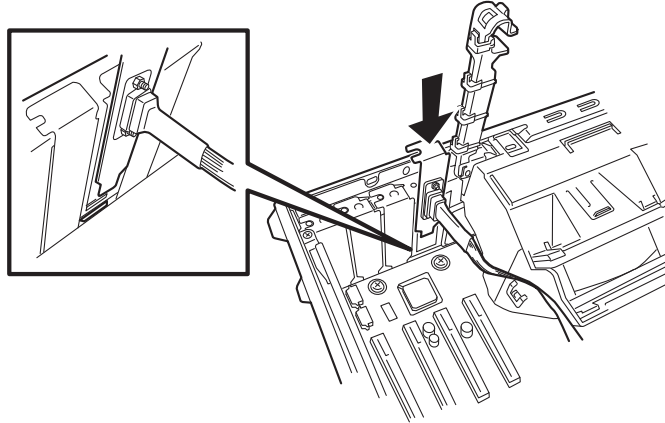

7. Arrange the cable so as not to buffer other PCI cards, and connect to the COM connector used for internal connections in the motherboard.
See the following for the position of the COM connector for internal connections.

Important Note the direction of the connector when connecting the cable.

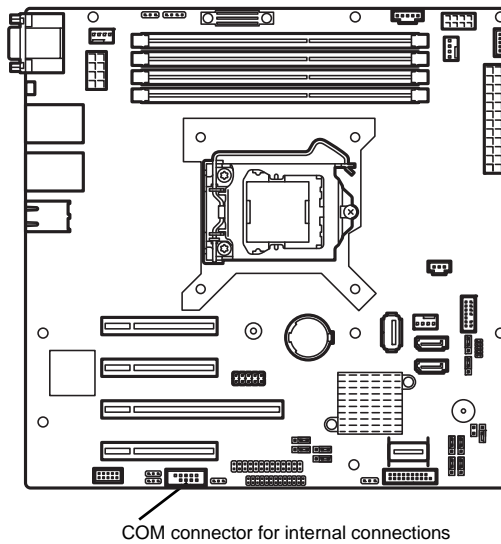

8. Reassemble the server.

1.12 HDD Cages

The N8154-65F 3.5-inch non-Hot Plug Drive Cage Kit (3.5-inch HDD cage) or N8154-71F 2.5-inch Hot Plug Drive Cage Kit (2.5-inch HDD cage) can be installed in the HDD bay in this server. The N8154-72F 2.5-inch Hot Plug Drive Cage Kit (extra 2.5-inch HDD cage) can be installed in 3.5-inch expansion bay 1.

Important Use hard disk drives provided by NEC.

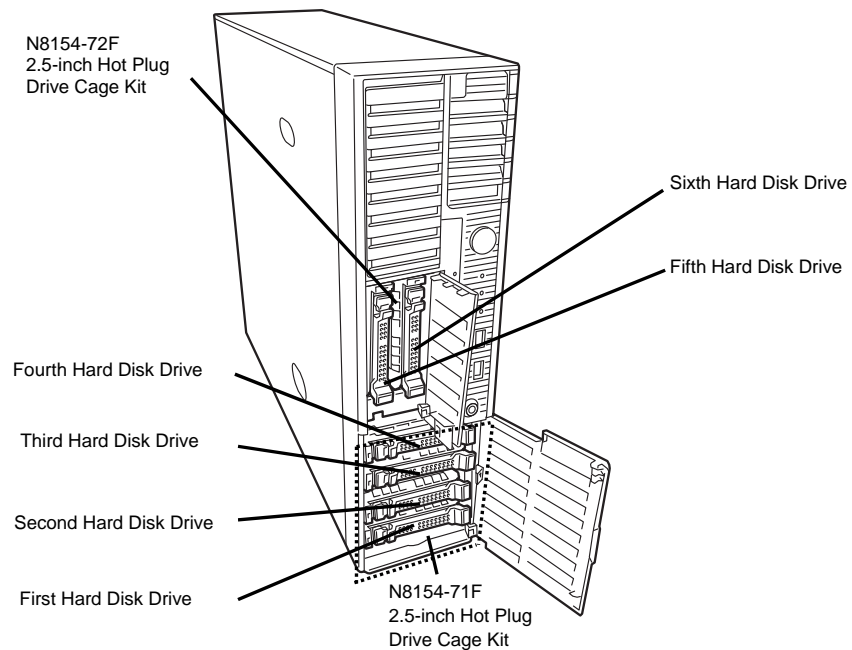
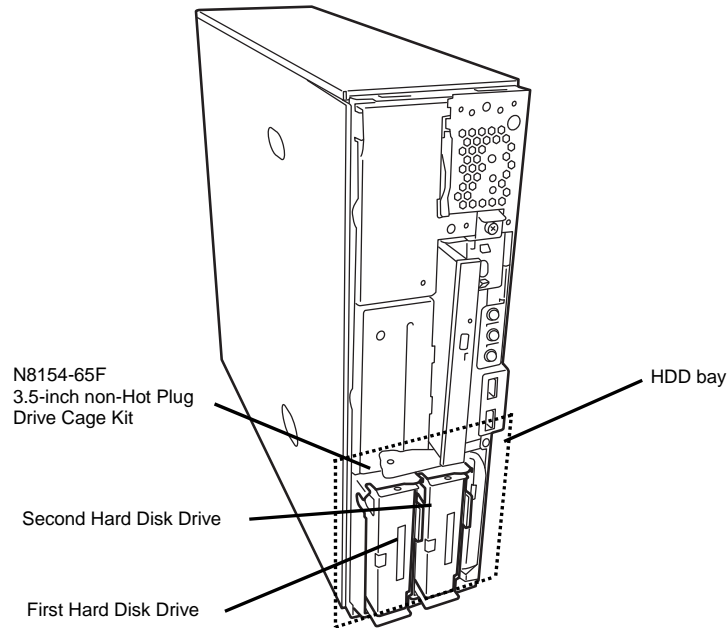

1.12.1 Installing a 3.5-inch HDD cage and hard disk drives

Install a 3.5-inch HDD cage in the server by using the following procedure.

1. See *Chapter 2 (1.3 Overview of Installation and Removal)* for preparations.
2. To remove the side cover and the front bezel, see *Chapter 2 (1.4 Removing the Side Cover and 1.5 Removing the Front Bezel)*.
3. Insert the HDD cage into the HDD bay.

The "C side" must face upward.

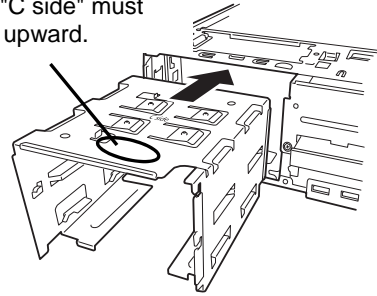

4. Push the HDD cage so that its tabs A and B come fit into the slits on the chassis.

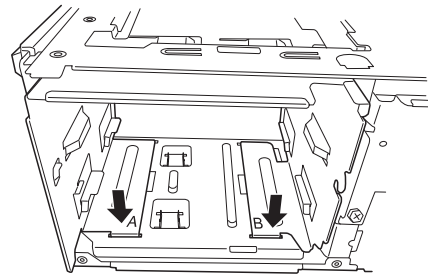

5. Insert one side of the lock plate into the slits of the chassis. Push the lock plate in the direction shown by the arrow to lock the HDD cage.

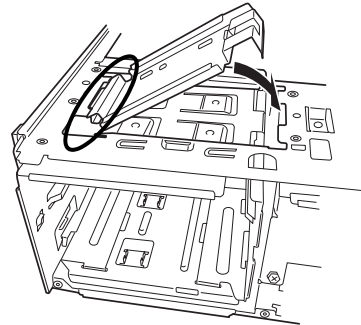

Important

Make sure to insert the lock plate into the groove of the chassis correctly. Incorrect installation causes the removal of the side cover to be impossible.

6. Mount the HDD trays that come with the HDD cage from both sides of the 3.5-inch hard disk drive. Mount the tray marked "A" on the left side, and the tray marked "B" on the right side. Mount the hard disk drive so that the flat face of the hard disk drive faces downward.

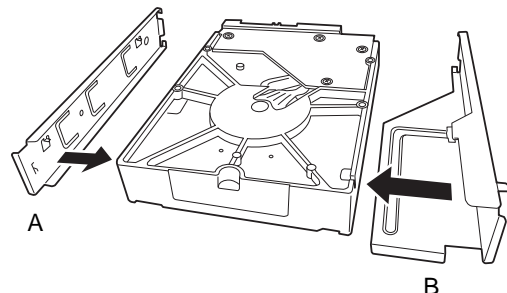

7. Insert the hard disk drive attached to the tray into the slot of the HDD cage.
When it is pushed to the end, it locks with a click.

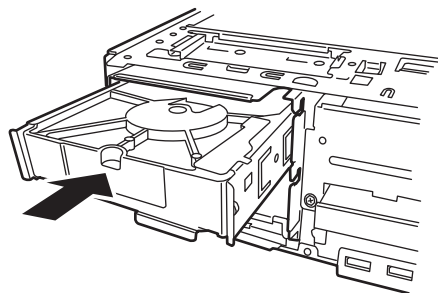

8. Connect the signal cable and the power cable to the hard disk drive. Use the signal cable that come with the HDD cage. Use the power cable connected to the motherboard in advance. For details about cable connection, see *Chapter 2 (1.15.1 Internal interface cables)*.
9. Attach the front bezel and the side cover you removed in step 2.

1.12.2 Removing hard disk drives

Remove the hard disk drives by using the following procedure.

Important When disposing of the hard disk drives, follow the instructions described in *Chapter 1 (1.2 Disposal of the Server and Consumables)* in the Maintenance Guide.

1. See *Chapter 2 (1.3 Overview of Installation and Removal)* for preparations.
2. To remove the side cover and the front bezel, see *Chapter 2 (1.4 Removing the Side Cover and 1.5 Removing the Front Bezel)*.
3. Disconnect the power cable and signal cable from the hard disk drives.
4. Press the part shown in the figure to unlock the HDD tray, and then remove the hard disk drive out from the HDD cage.
5. Assemble the server.

1.12.3 Installing a 2.5-inch HDD cage and hard disk drives

When a 2.5-inch HDD cage is installed in this server, four to six SAS/SATA hard disk drives or SSDs can be installed.

Combining SATA/SAS Hard Disk Drives and SSDs

- An optional RAID controller is required to use SAS hard disk drives together with SSDs.
- An optional RAID controller is required to install five or more hard disk drives.
- You cannot mix them within the same RAID array.
- You cannot use SAS hard disk drives that have different rotation speeds.
- Mount SATA/SAS hard disk drives in order from slot 0, and mount the SSDs to the remaining slots.

The N8154-71F 2.5-inch HDD cage, which is a required BTO option, can mount a SAS HDD, and the N8154-72F 2.5-inch extra HDD cage can mount a SATA HDD, and vice versa.

Important Use hard disk drives provided by NEC.

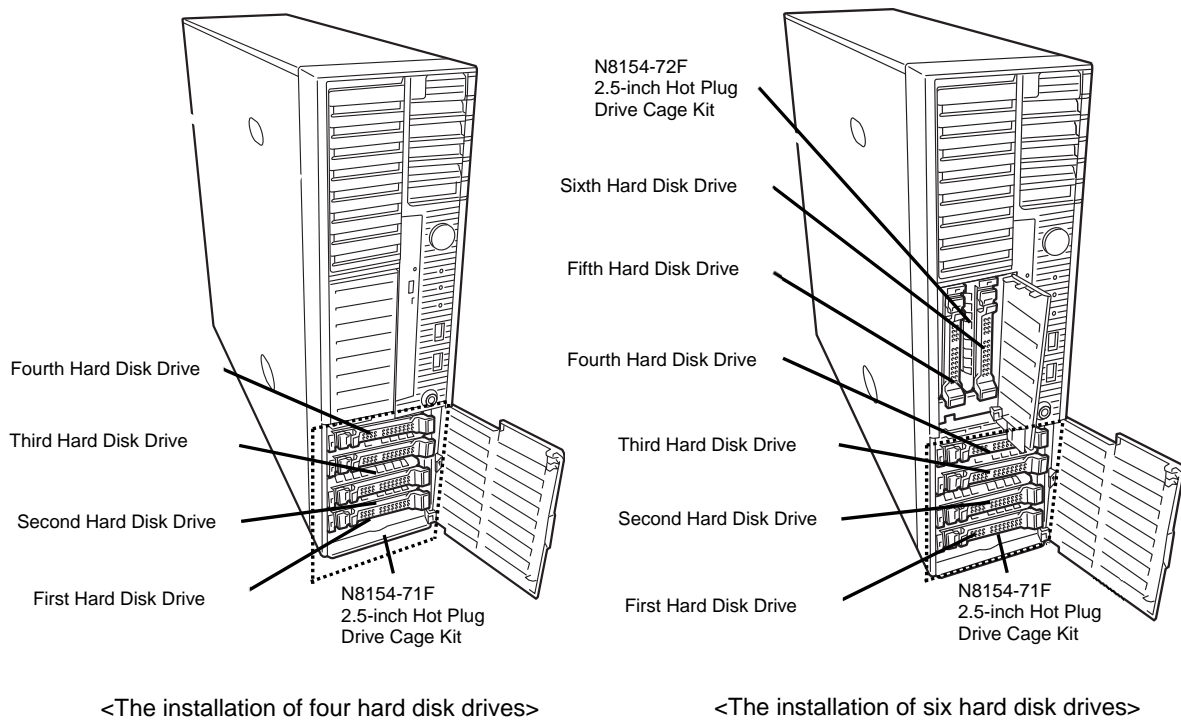

Important Install the hard disk drives sequentially starting from slot 0.

Install a 2.5-inch HDD cage in the server by using the following procedure.

1. See *Chapter 2 (1.3 Overview of Installation and Removal)* for preparations.
2. To remove the side cover and the front bezel, see *Chapter 2 (1.4 Removing the Side Cover and 1.5 Removing the Front Bezel)*.
3. Set the jumper for the backplane board installed in the HDD cage. The jumper setting when the onboard SATA controller (LSI Embedded MegaRAID) is used differs from that when the optional RAID controller is used. For details, see *Chapter 2 (1.9 Use of Internal Hard Disk Drives in the RAID System)*.

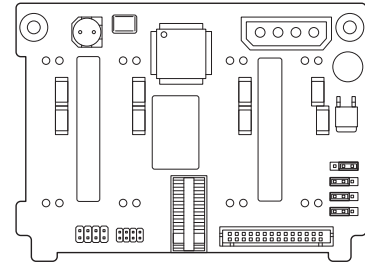

4. Mount the rollers that come with the HDD cage on the holes inside the HDD bay (10 places).

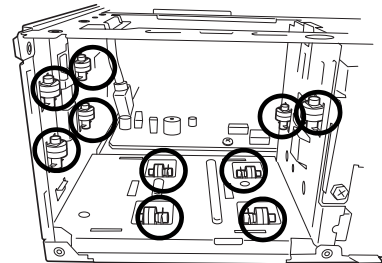

5. Insert the HDD cage into the HDD bay. The "C side" must face upward. Do not push the HDD cage to the end for connecting cables later.

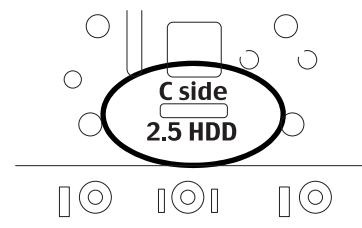
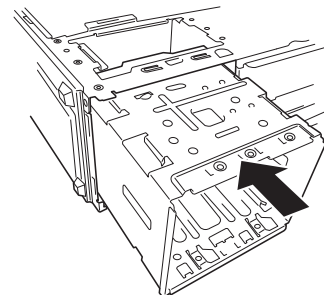

6. Connect the interface cable and power cable to the HDD cage. Use the interface cable that comes with the HDD cage. Use the power cable connected to the motherboard in advance. For details of cable connection, see *Chapter 2 (2.2.1 Interface cables)* described later.
7. Push the HDD cage to the end. Insert one side of the lock plate into the slit of the chassis. Push the lock plate in the direction shown by the arrow to lock the HDD cage.

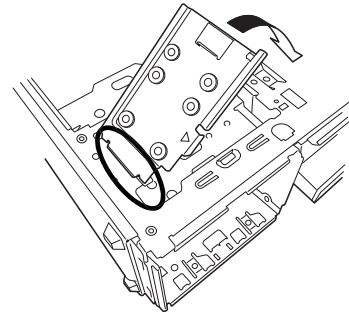

Important Make sure to insert the lock plate into the groove of the chassis correctly. Incorrect installation causes the removal of the side cover to be impossible.

1.12.4 Installing an extra 2.5-inch HDD cage

Two hard disks can be added by using an extra 2.5-inch HDD cage.

Tips

With a liquid-cooled server, an extra 2.5-inch HDD cage cannot be used at the same time as a backup device.

Install an extra 2.5-inch HDD cage in the server by using the following procedure.

1. See *Chapter 2 (1.3 Overview of Installation and Removal)* for preparations.
2. To remove the side cover and the front bezel, see *Chapter 2 (1.4 Removing the Side Cover and 1.5 Removing the Front Bezel)*.
3. Remove one screw and the dummy cover from the 3.5-inch expansion bay.

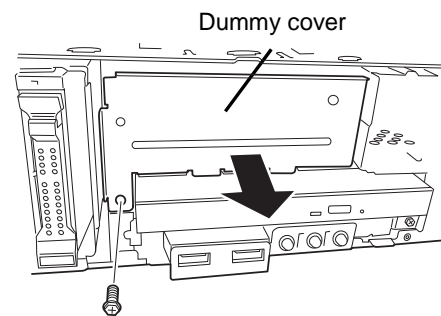

4. Insert an extra 2.5-inch HDD cage into the 3.5-inch expansion bay. Do not push the HDD cage to the end for connecting cables later.

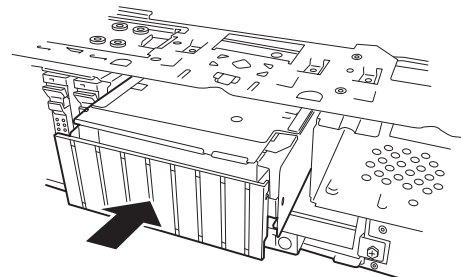

5. Connect the interface cable that comes with the HDD cage and the power cable on the motherboard. For details, see *Chapter 2 (1.15 Connecting)*.
6. Push the HDD cage to the end and secure it with two screws.

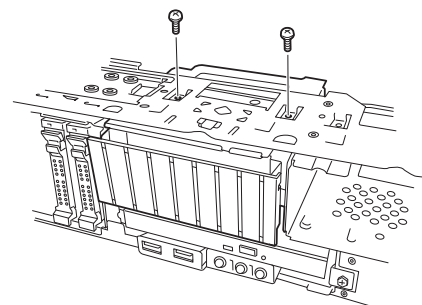

7. Attach the front bezel and the side cover.

8. Open the front door of the standard 2.5-inch HDD cage. Slide the tab on the bezel of the extra 2.5-inch HDD cage in the direction shown by the arrow, and then remove it from the bezel. Sliding this tab toward the outside of the bezel enables you to lock the bezel of the extra 2.5-inch HDD cage when the front door of the standard 2.5-inch HDD cage is closed.

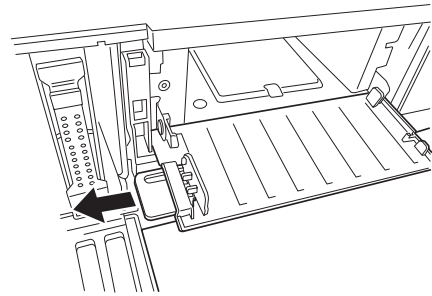

1.12.5 How to open the extra 2.5-inch HDD cage door

Open the extra 2.5-inch HDD cage in the server by using the following procedure.

1. Unlock and open the door of the 2.5-inch hard disk drive bay.

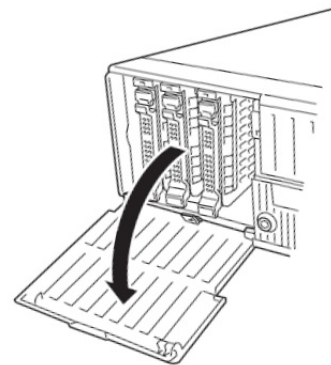

Note

You need to open the 2.5-inch HDD bay first to open the extra 2.5-inch HDD cage door.

2. Lay down the server horizontally, and then insert your finger into the opening located on the right side of the extra 2.5-inch HDD cage door and push the door to the right (see (1) below) to unlock the door. Pull the door toward the front (see (2) below) to open.

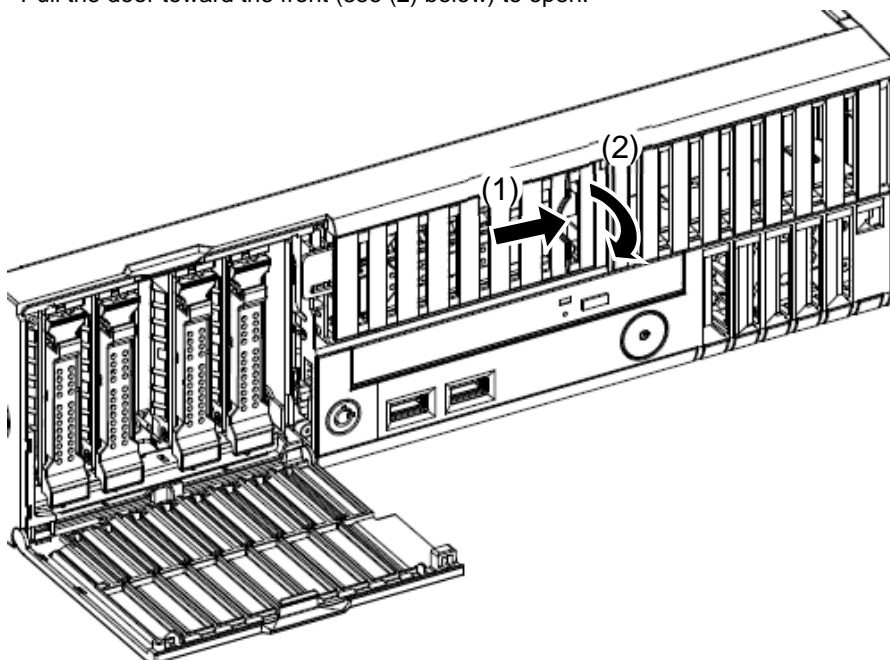

1.12.6 Installing the hard disk drive

Install a 2.5-inch hard disk drive in the server by using the following procedure.

1. Unlock and open the door of the 2.5-inch drive bay.

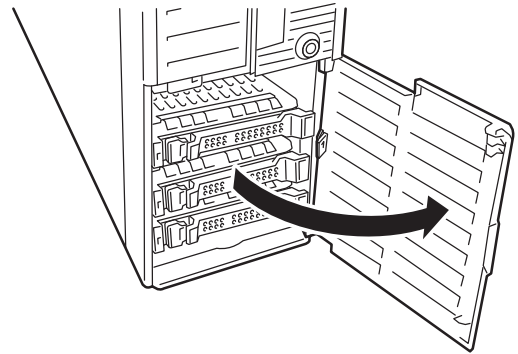

2. Install the hard disk drives in the HDD cage.
Fully open the lever on the hard disk drive tray, and then insert the hard disk drive until it comes into contact with back of the HDD cage (1).
When finished, close the lever to lock the hard disk drive (2).

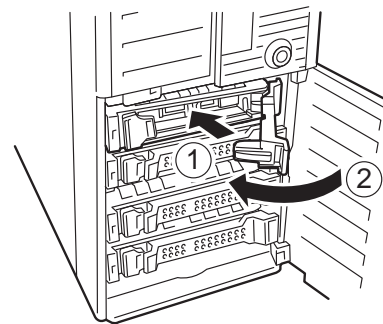
**Important**

- Use only the hard disk drives provided by NEC.
- If you remove two or more hard disk drives while the server is on, the logical drive will be damaged. Remove or replace the hard disk drives one by one.

Note

Make sure that the orientation of the hard disk drive (tray) before insertion is correct. In addition, make sure that the hook of the lever engages with the frame of the HDD cage when the lever is closed.

3. Close the door and lock it by using the key.

1.13 Optical Disk Drive

Procedures for replacing the standard optical disk drive with the optional internal DVD SuperMULTI drive are described below.

Important Do not install a third party's drive.

1.13.1 Replacing drives

Follow the procedure below to replace your drive with the optional internal DVD SuperMULTI drive.

1. See *Chapter 2 (1.3 Overview of Installation and Removal)* for preparations.
2. To remove the side cover and the front bezel, see *Chapter 2 (1.4 Removing the Side Cover and 1.5 Removing the Front Bezel)*.
3. If a device or an extra 2.5-inch HDD cage is installed in the 3.5-inch expansion bay (1), remove it so that you can access the cable connected to the optical disk drive.
4. Disconnect the SATA cable and DC power cable from the optical disk drive.

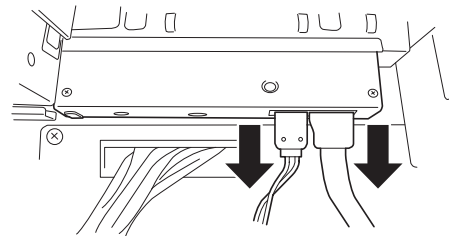

5. Push the stopper on the right side and remove the optical disk drive.

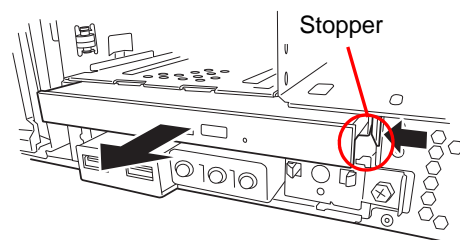

6. Remove the bracket from the optical disk drive.

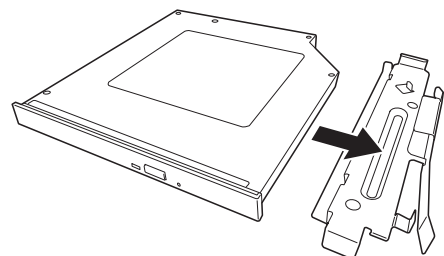

7. Mount the bracket for the optical disk drive on the DVD SuperMULTI drive.

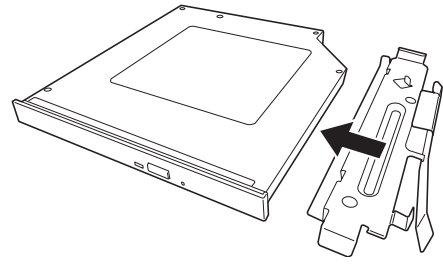

8. Install the bracket with DVD SuperMULTI drive installed to the server.
9. Connect the SATA cable and DC power cable you disconnected in step 3 to the server.

This completes the installation procedures.

***1.13.2* Removal**

You can remove the optical disk drive by reversing the installation procedure.

1.14 Backup Devices

The 3.5-inch expansion bay of the server can contain a backup device such as a magnetic tape drive. In an air cooled server, install the backup device in 3.5-inch expansion bay 2. In a liquid-cooled server, install the backup device in 3.5-inch expansion bay 1.

Tips

An optional internal USB cable is required to install a backup device.

- K410-276(00) internal USB cable (USB 3.0)
- K410-286(00) internal USB cable (USB 2.0)

Prepare whichever cable is appropriate for your configuration.

In a liquid-cooled server, the backup device cannot be used at the same time as an extra 2.5-inch HDD cage.

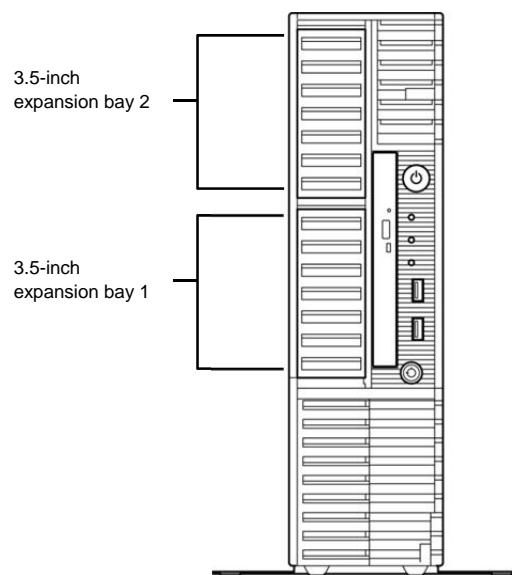

1.14.1 Installation

Install a backup device by using the following procedure.

1. See *Chapter 2 (1.3 Overview of Installation and Removal)* for preparations.
2. To remove the side cover and the front bezel, see *Chapter 2 (1.4 Removing the Side Cover and 1.5 Removing the Front Bezel)*.
3. Remove the blank cover. Push the tab on the tray and pull out the device tray from the 3.5-inch expansion bay.

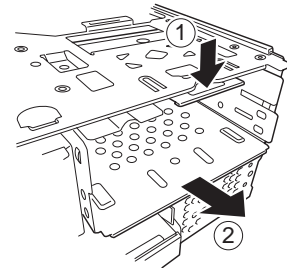

4. Mount the backup device on the device tray. Secure the backup device on the left and right sides by using the two screws that come with the server.

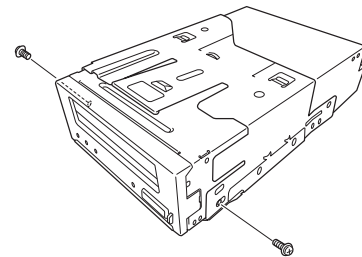

Important Use two screws supplied with this server to attach the backup device to the tray.

5. Insert the backup device into chassis.
Do not push the backup device in completely as the cable has to be connected to the device.

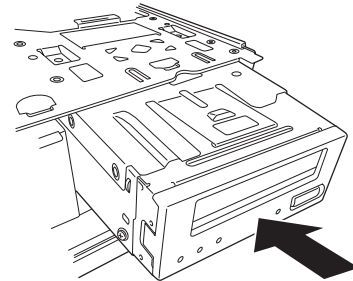

6. Connect the interface cable and power cable to the installed 3.5-inch backup device.
For more information, see *Chapter 2 (1.15 Connecting)*.
7. Push the device all the way until it locks with a clicking sound.
8. Assemble the server.
9. Install device drivers for installed backup device as needed.
For more information, refer to the manual provided with the backup device.

1.14.2 Removal

You can remove the backup device by reversing the installation procedure. If the devices are to remain removed, attach the stored dummy cover.

1.15 Connecting Cables

This section shows an example of internal device cable connection.

1.15.1 Internal interface cables

This section describes the connection of internal interface cables.

Tips

The figure shown here primarily describes connections. For more information about the connectors on the motherboard, see *Chapter 1 (4.4 Motherboard)*.

(1) Connecting hard disk drives

This section describes how to connect additional hard disk drives.

(a) In case of 3.5-inch hard disk drive installed

Connect the cables as in the following figure when adding 3.5-inch hard disk drives. Install the hard disk drives in order from the left side.

Connect the first Hard Disk Drive to SATA0, the second to SATA1.

- **Connecting to the miniSAS connector on the motherboard**

A dedicated cable (K410-278(00)) is required.

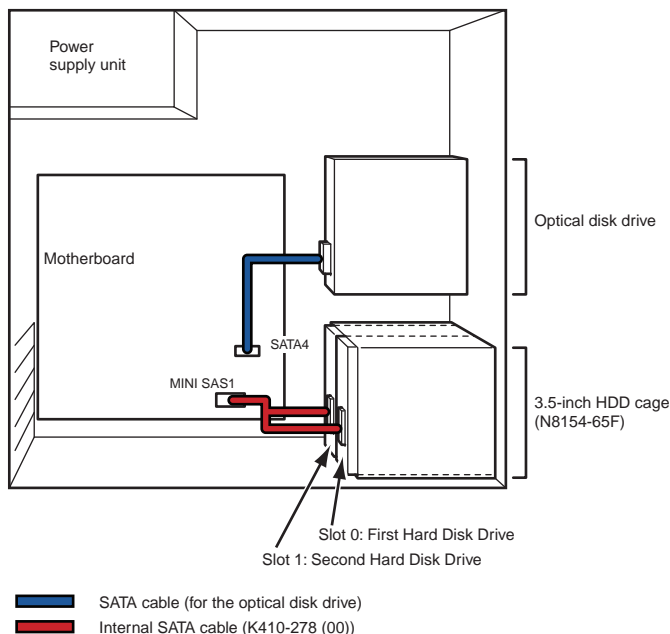

You can use the controller on the motherboard to build a RAID system. For more information, see *Chapter 2 (4. RAID System Configuration)* in "*Maintenance Guide*".

• **Connecting a RAID controller (N8103-172) and an extra 2.5-inch HDD cage (N8154-72F)**

When a RAID controller (N8103-172) is installed and an extra 2.5-inch HDD cage (N8154-72F) is connected, dedicated cables (K410-277(00) and K410-287(00)) are required. Do not use the cable that comes with the extra 2.5-inch HDD cage (N8154-72F).

Install the hard disk drives sequentially starting from the leftmost slot when viewed from the front.

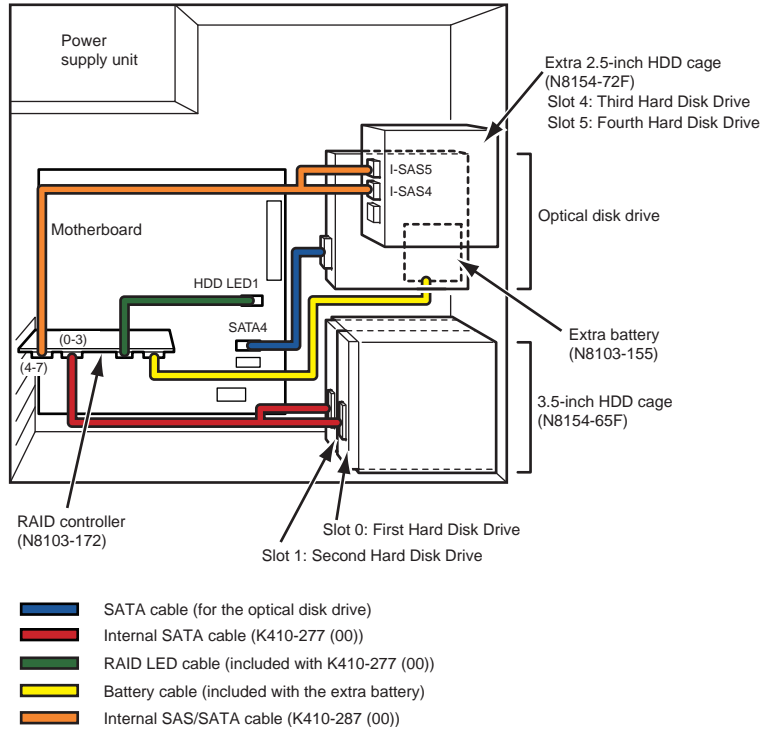

• **About RAID LED cables**

The DISK access LED on the front of the equipment shows the access status of hard disk drives that are connected to a RAID controller. To display this status, connect the LED cable that comes with the optional cable K410-277(00).

Connect the LED connector on the motherboard to the connector on the RAID controller.

See the figures below and connect the LED cable to the LED connector of the motherboard.

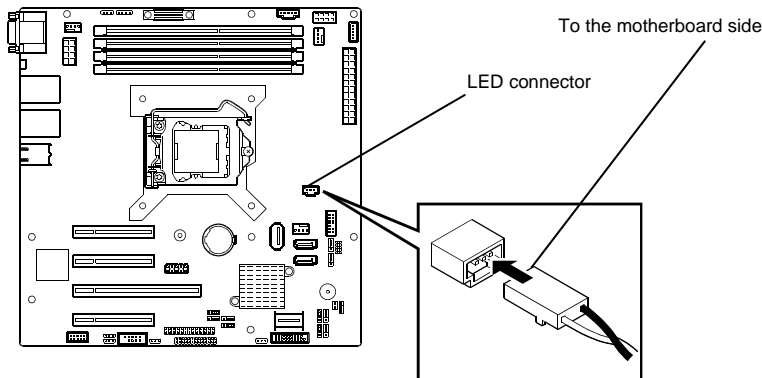

(b) In case of 2.5-inch hard disk drive installed

Connect the cables as in the following figure when adding 2.5-inch hard disk drives. Install the hard disk drives in order from slot 0.

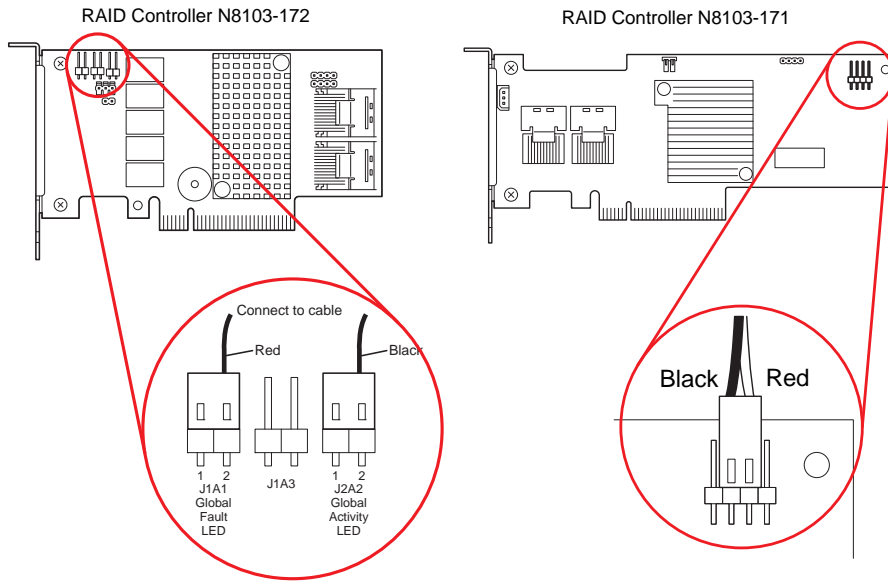

- **Connecting to the miniSAS connector on the motherboard**
Use the cable that comes with the 2.5-inch HDD cage N8154-71F. Install hard disk drives from Slot 0 in ascending order.

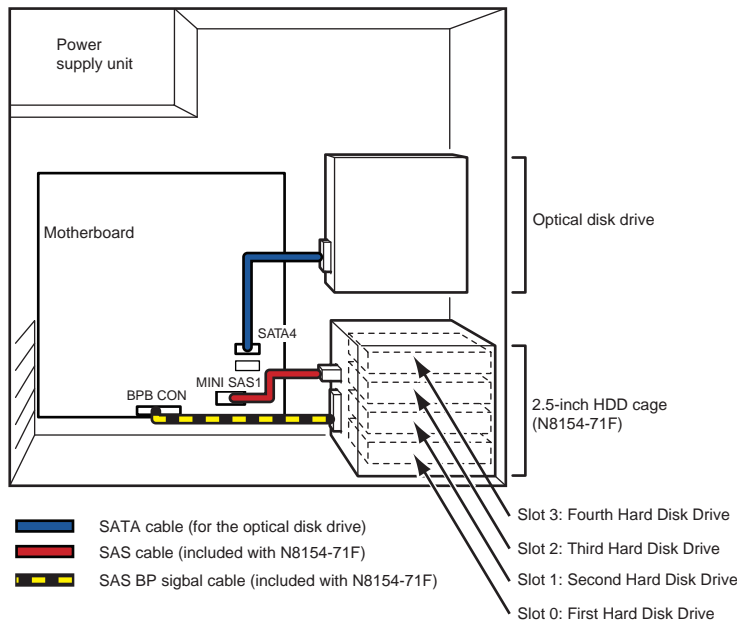

• **Adding a RAID controller (N8103-171/172/173/174/168)**

When SAS or SATA hard disk drives are installed and used in a RAID system with a RAID controller (N8103-171/172/173/174/168), the dedicated cable K410-180(00) is required. Install hard disk drives from Slot 0 in ascending order.

[Connecting four hard disk drives]

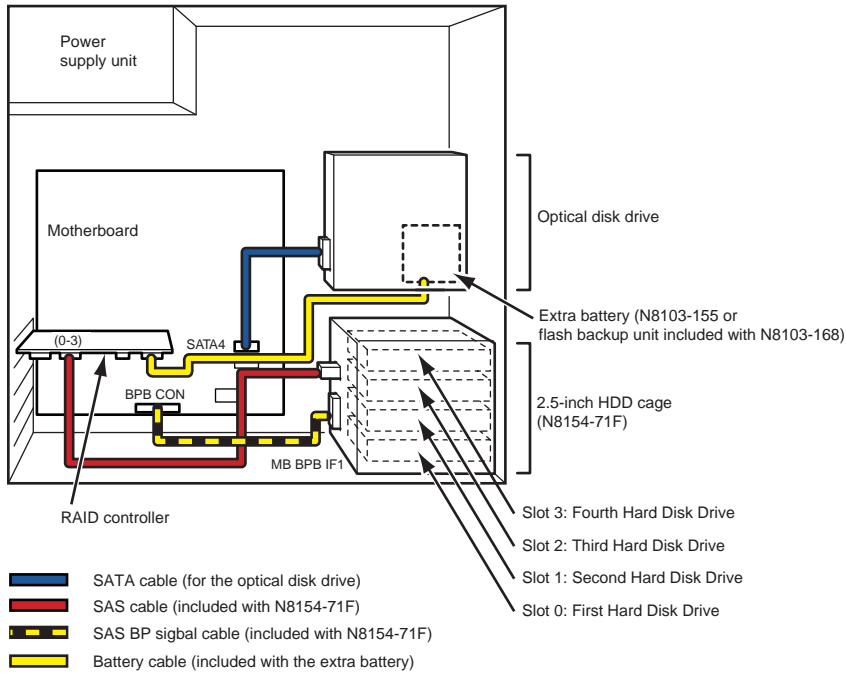

* N8103-171 does not support the extra battery.

[Connecting six hard disk drives]

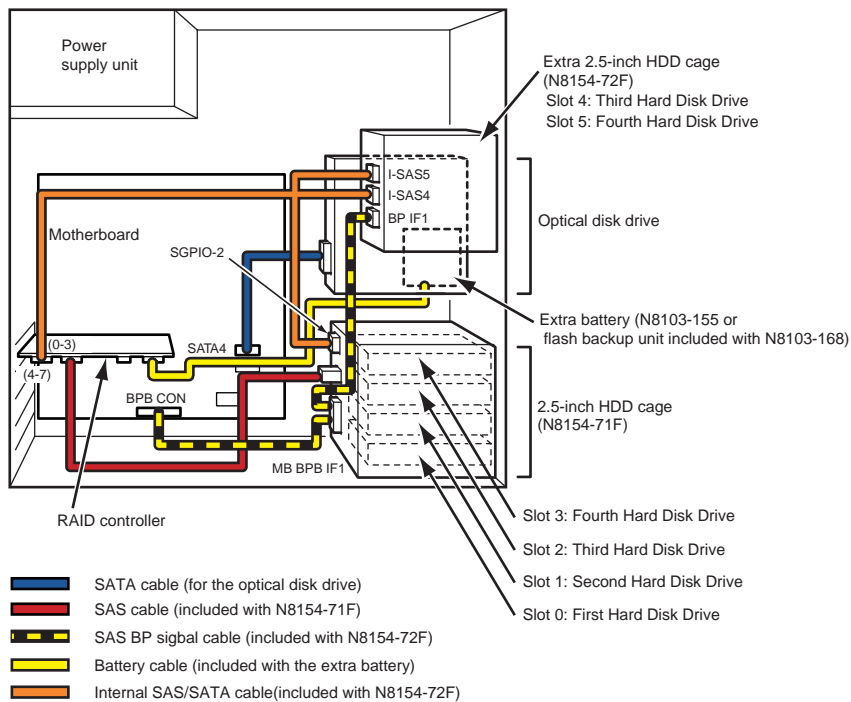

* N8103-171 does not support the extra battery.

(2) Connecting backup devices

The 3.5-inch expansion bay of the server can mount USB devices for internal connection.

(a) Mounting an internal USB device on Air Cooling model

Use the dedicated internal USB cable (for USB 3.0: K410-276(00), for USB 2.0: K410-286(00)).

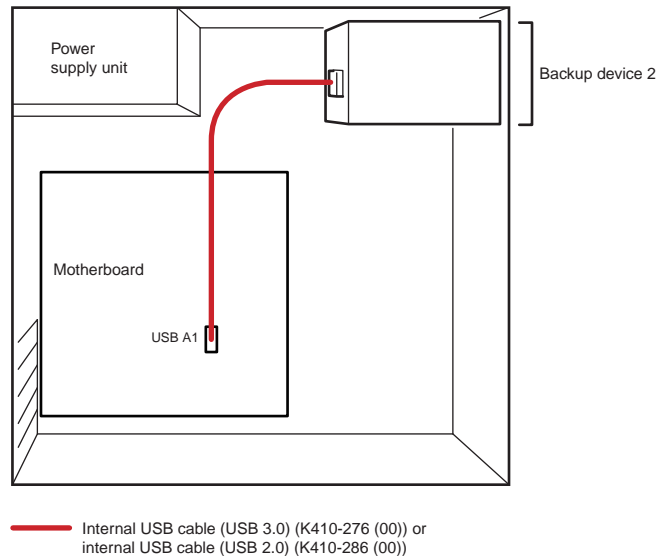
**(b) Mounting an internal USB device on Liquid Cooling model**

Use the dedicated internal USB cable (for USB 3.0: K410-276(00), for USB 2.0: K410-286(00)).

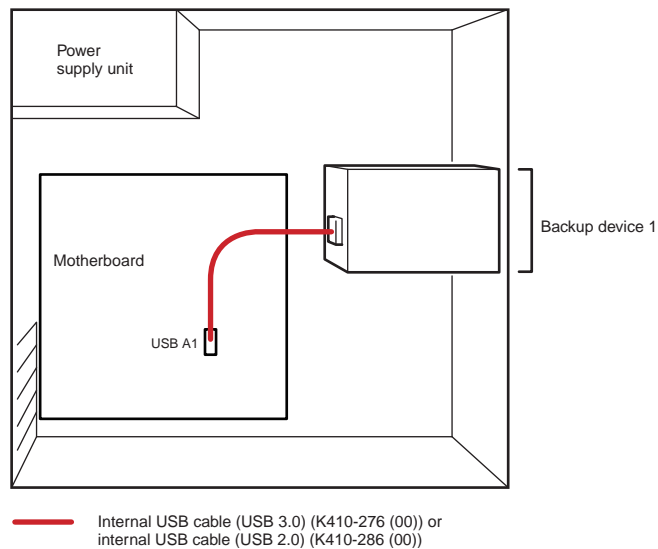

1.15.2 Power cables

The figure below shows an example of connecting the power cables. Power cables other than those shown here are not used by the devices.

(1) Using 3.5-inch hard disk drives in air cooling model, an extra 2.5-inch HDD cage and a backup device

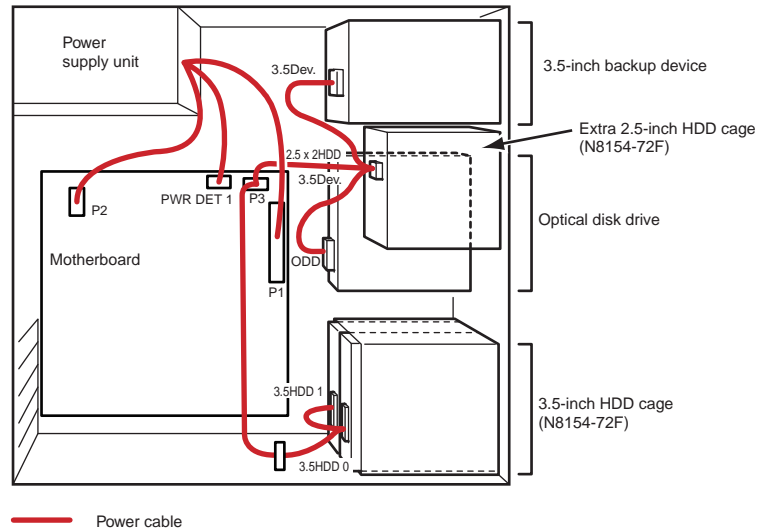

(2) Using 3.5-inch hard disk drives in liquid cooling model and an extra 2.5-inch HDD cage

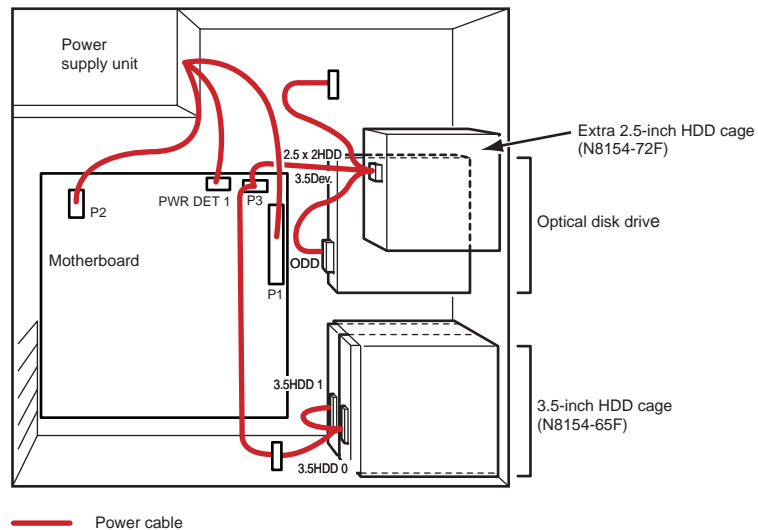

(3) Using 3.5-inch hard disk drives in liquid cooling model and a backup device

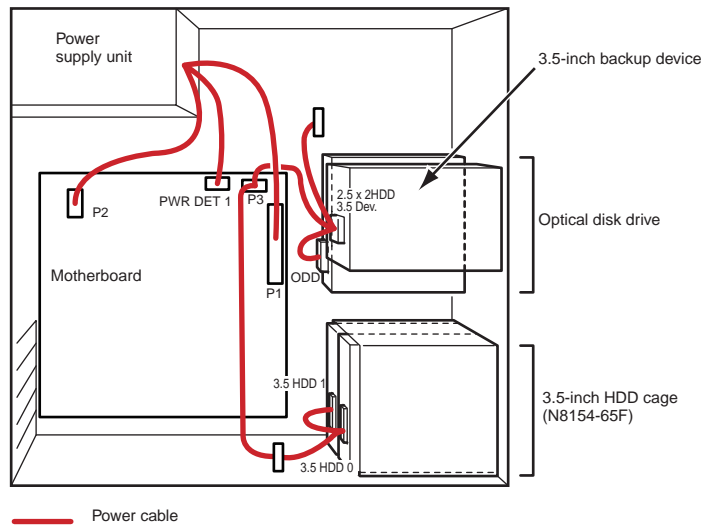

(4) Using 2.5-inch hard disk drives in air cooling model, an extra 2.5-inch HDD cage and a backup device

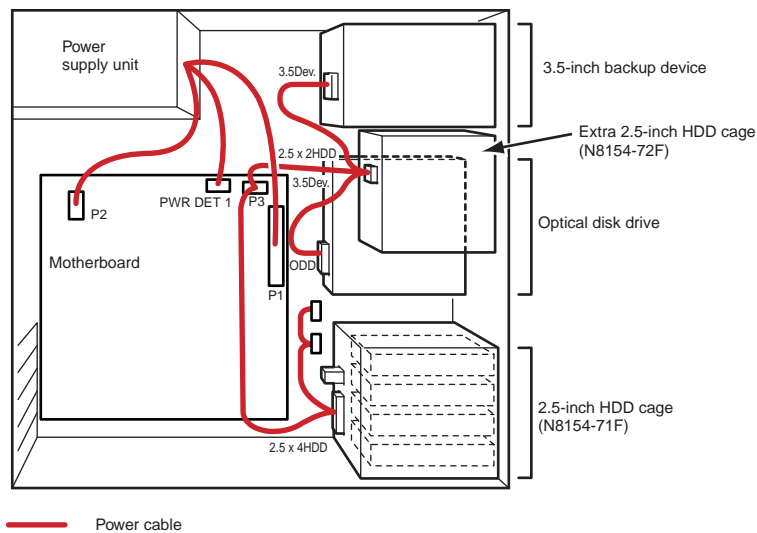

(5) Using 2.5-inch hard disk drives in liquid cooling model and an extra 2.5-inch HDD cage

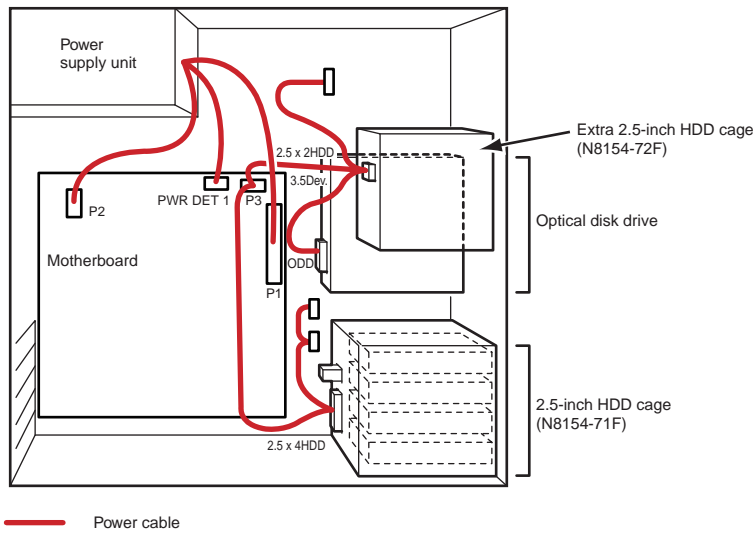

(6) Using 2.5-inch hard disk drives in liquid cooling model and a 3.5-inch backup device

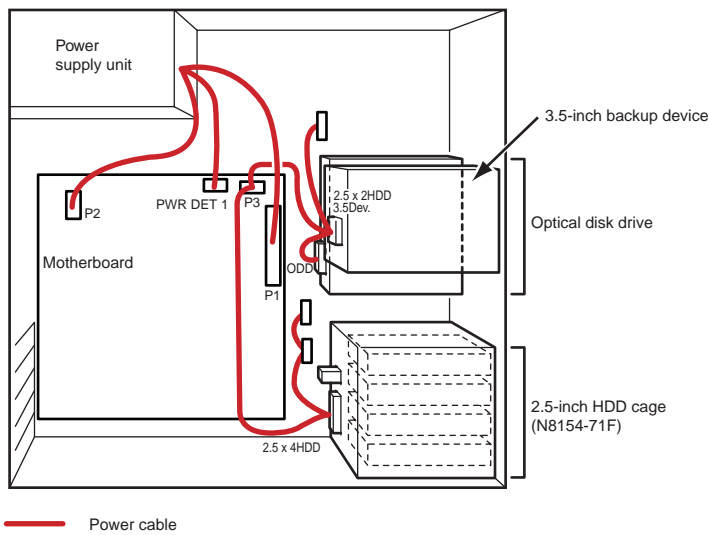

1.16 Attaching the Front Bezel

You can attach the front bezel by reversing the removal procedure. Insert the tab inside the front bezel into the hole on the front upper side of the server, push the left side of the front bezel toward the server, and then lock the bezel by using the tab on the upper side of the bezel. Secure the screw to fix the bezel onto the chassis.

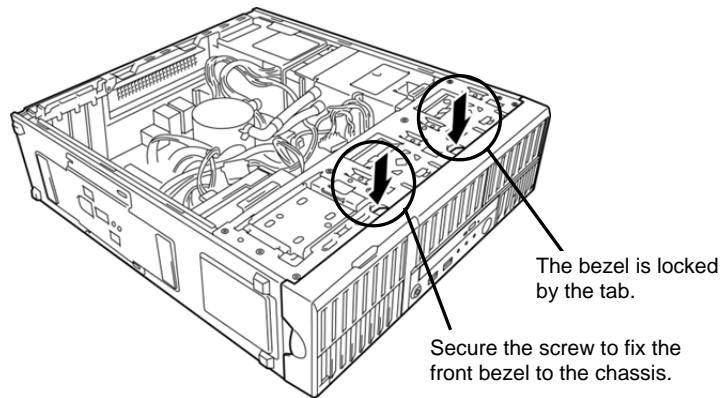
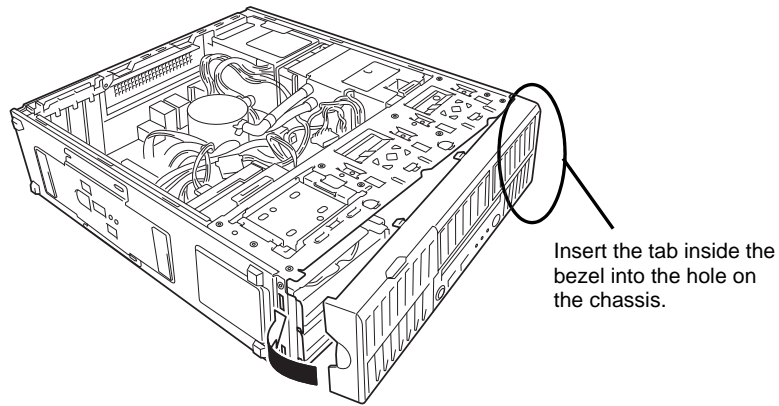

1.17 Installing the Side Cover

You can attach the side cover by reversing the removal procedure.

Make sure that hooks at both the top and bottom of the side cover are securely inserted in the holes on the server frame. Also make sure that the hooks at the front of the cover are engaged with the server frame when sliding the side cover forward to attach. If they are not engaged with the frame, the cover cannot be secured in place.

2. Installation and Connection

This section describes how to position the server and connect cables.

2.1 Installation

⚠ CAUTION



Be sure to observe the following precautions to use of the server safely. Failure to observe the precautions may cause burns, injury, and property damage. For details, refer to *Safety precautions in Precautions for Use*.

- Do not attempt to lift the server by gripping the front bezel.
- Install and store only in the specified environment.

The environment suitable for the server is as follows.

Hold the server firmly, and slowly and gently place it in the position in which it is to be installed.

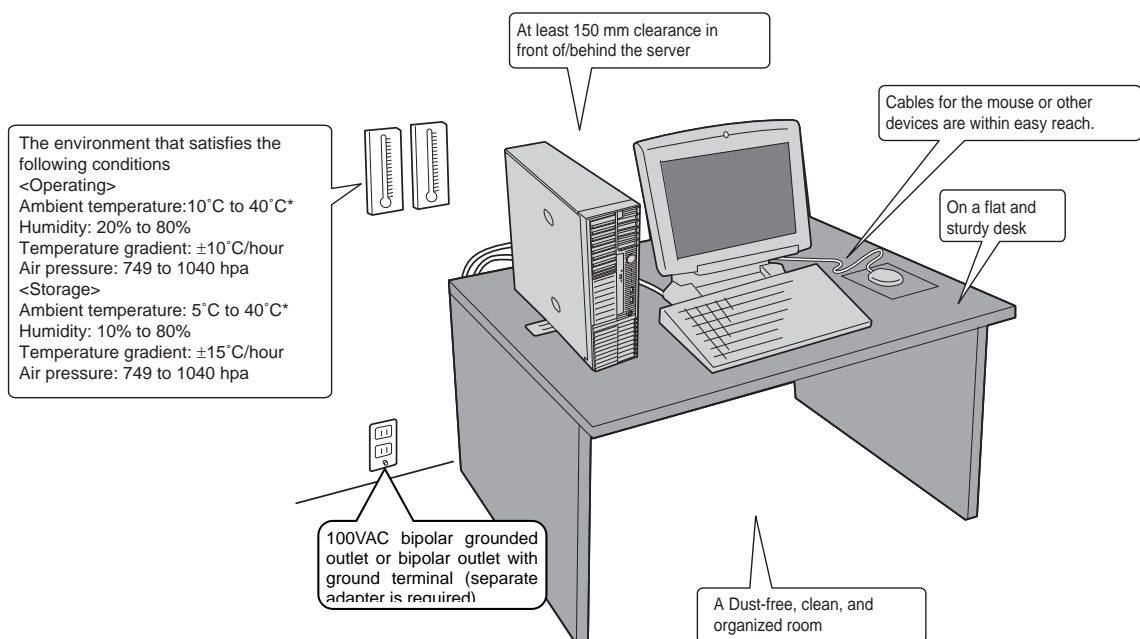

Do not install the server in an environment in which any of the following conditions apply: Installing the server in any of the following conditions will cause the server to malfunction.



2.1.1 Preparation for installation

(1) Mounting for vertical

For vertical use of the server, set the stabilizer attached to the bottom of the server as instructed below.

Removing/installing the stabilizer

Removing the stabilizer

Release the lock lever and slide it in the direction of the arrow to remove.

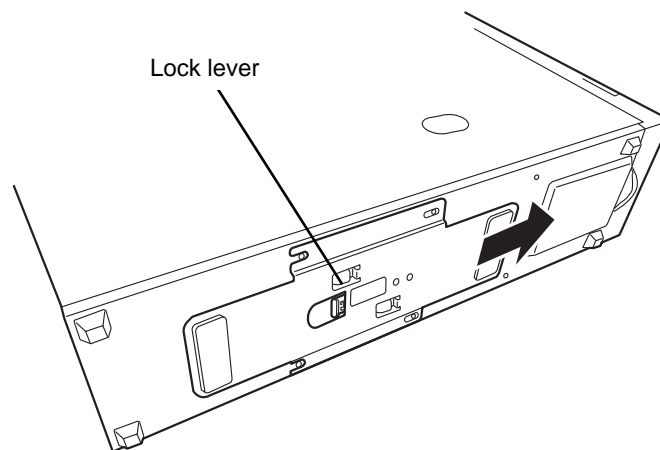

Installing the stabilizer

Insert the tab of the stabilizer into the slot of the server as shown in the figure below.

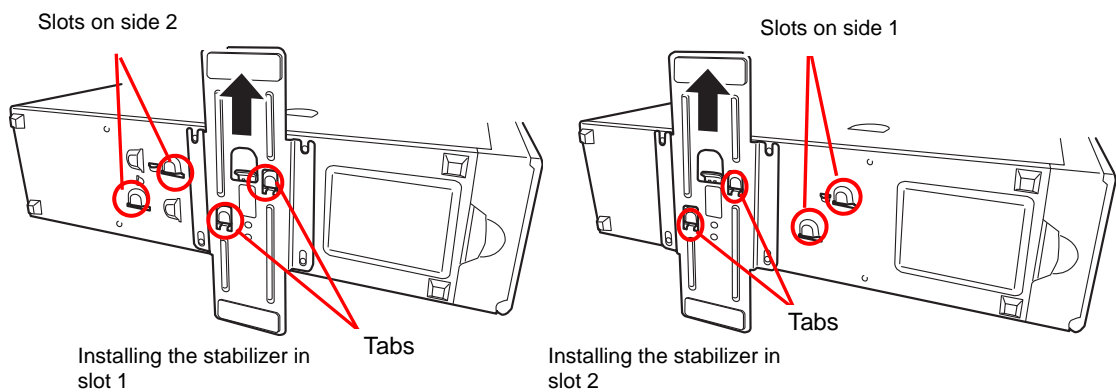

Set up the server as shown in the figure after attaching the stabilizers.

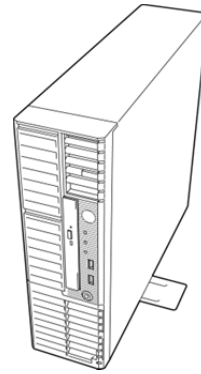

Tips

When two or more servers are installed vertically side by side, installing the stabilizers in slots 1 and 2 alternately can remove the gap between servers.

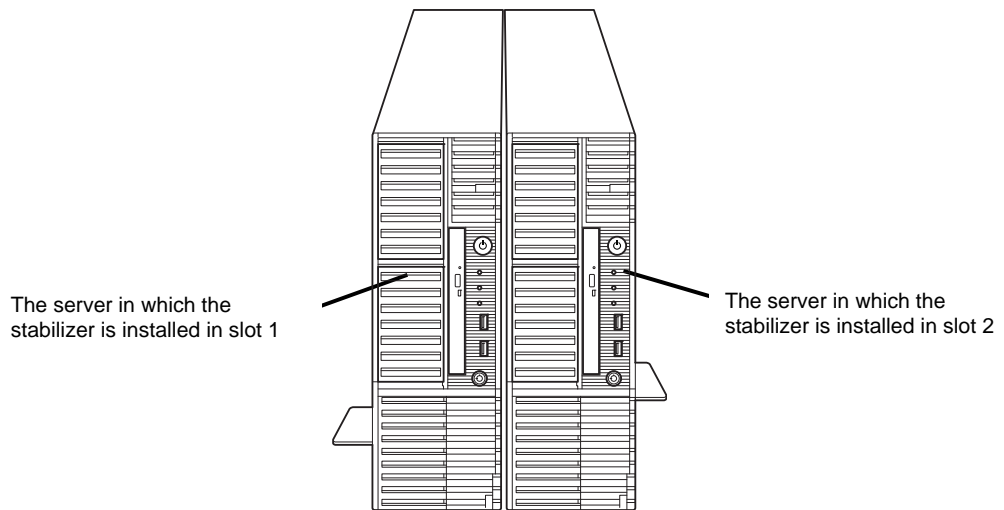

(2) Mounting for horizontal

To mount the server horizontally, attach the provided rubber feet to the positions shown in the figure.

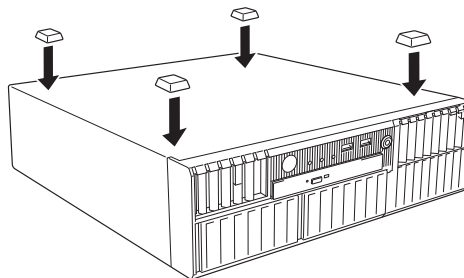

Attach the rubber feet on the right side of the server as shown in the figure.



Important

When the server is horizontally mounted, do not put devices that weigh more than 5 kg on the server.

2.2 Connection

Connect peripheral devices to the server. Connectors that enable a variety of peripheral devices to be connected are provided at the front and rear of the server. Figures on the following pages show the peripheral devices that can be connected as standard. Connect the peripheral devices before connecting the power cord to the server.



 **WARNING**



Be sure to observe the following precautions to use the server safely. Failure to observe the precautions may cause death or serious injury. For details, refer to *Safety precautions in Precautions for Use*.

- Do not hold the power plug with wet hands.

 **CAUTION**



Be sure to observe the following precautions to use of the server safely. Failure to observe the precautions may cause burns, injury, and property damage. For details, refer to *Safety precautions in Precautions for Use*.

- Use only the specified outlet to insert.
- Do not connect the power cord to an outlet that has an illegal number of connections.
- Insert the power plug into the outlet as far as it goes.
- Use only the specified power cord.
- Do not connect or disconnect the interface cable while the power cord is connected.
- Use only the specified interface cable.

2.2.1 Interface cables

Connect the interface cable before connecting the power cord.

Important

- Turn off the server and peripheral devices to be connected before connecting.
- The connectors that are not explained here are not available. Do not connect anything to the connectors.

<Front view>

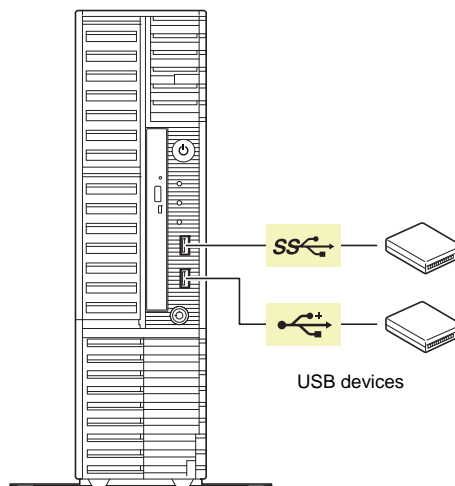

<Rear view>

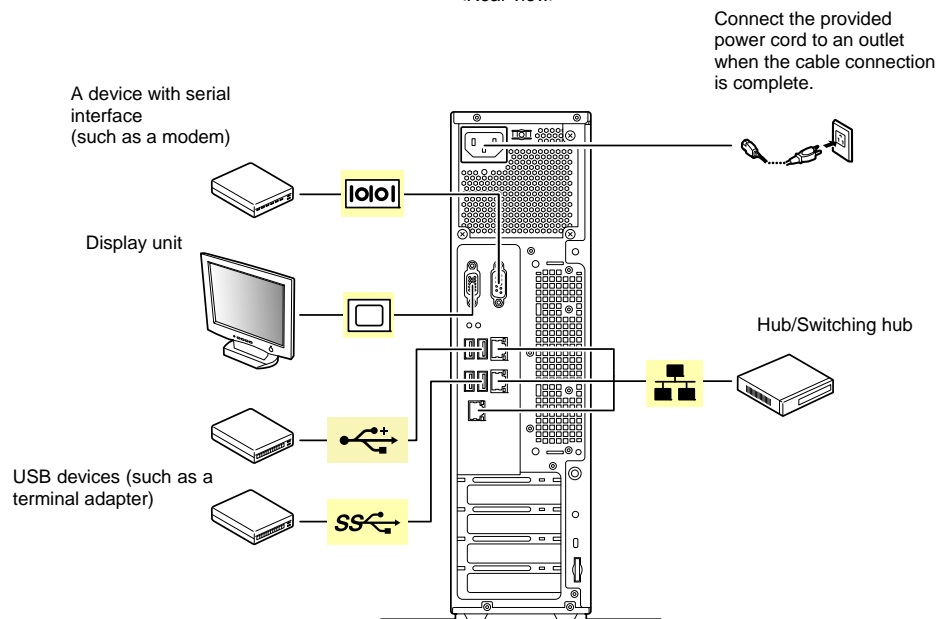

2.2.2 Power cord

Connect the provided power cord to the server.

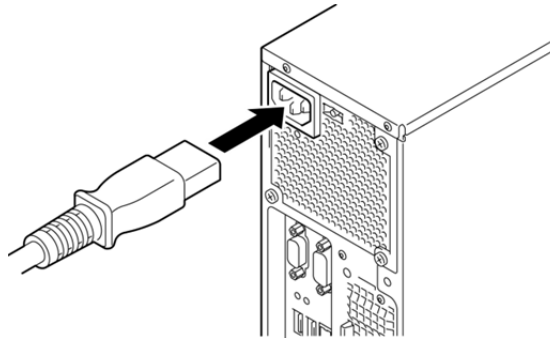

When the power cord is connected to an outlet, POWER LED lights amber during initialization of the system.

Tips

- To connect the power cord to a UPS, connect it to the outlet provided at the rear of the UPS. For details, refer to the instruction manual supplied with the UPS
- In order to link the power supply from the UPS with the power-on/off of this server, the BIOS settings change are required depending on the UPS to which the power cord of this server is connected.
In the BIOS Setup Utility, select **Server**, and then **AC-LINK** to change the parameter to the appropriate value.

NEC Express5800 Series Express5800/T110g-S

3

Setup

This chapter describes how to set up the server.

1. Turning on the Server

Power-On Self-Test (POST) is explained in this section.

2. System BIOS Setup

You can customize BIOS settings by following the instructions in this section.

3. EXPRESSSCOPE Engine 3

EXPRESSSCOPE Engine 3 provides useful features through the Baseboard Management Controller (BMC).

4. EXPRESSBUILDER

EXPRESSBUILDER helps you to install Windows and maintain the server.

5. Installing Software Components

You can install Windows and bundled software by following the instructions in "*Installation Guide (Windows)*".

6. Turning off the Server

Turn off power when not using the server.

1. Turning on the Server

Turn on the server by using the following procedure.

Important Wait for at least 10 seconds before turning on the server again after the power has been turned off.

1. Disconnect Flash FDD if applicable.
2. Turn on the peripheral devices such as display unit.

Note If the power cord is connected to power control system such as an Uninterruptible Power Supply (UPS), make sure that the power control system is turned on.

3. If POWER LED lights amber, wait until POWER LED is unlit.
4. Press POWER Switch at the front of the server.
POWER LED is turned on green and after a while, the NEC logo appears on the display.
While the NEC logo is being displayed, the self-diagnostic program (POST) runs and diagnoses the hardware. For details, see *Chapter 3 (1.1 POST)*.

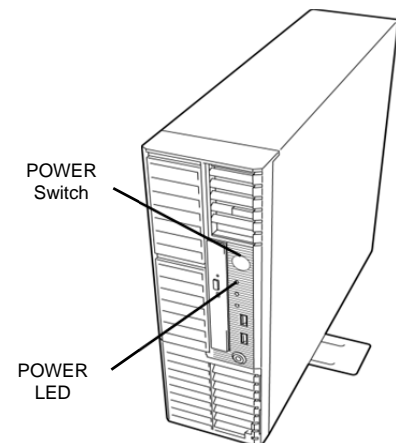

1.1 POST

Power-On Self-Test (POST) is a self-diagnostic program stored in the server as standard. POST automatically runs immediately after the server is turned on and checks the motherboard, memory, processor (CPU), keyboard, and mouse. POST also displays the start-up messages of different utilities during the operation.

Usually, you do not need to check the message of POST. Check messages displayed at POST in the following cases:

- When introducing a server
- If you suspect a failure
- When you hear beep many times during the time between the power on and OS startup
- When any error message is displayed

1.1.1 POST sequence

Explains how POST runs in order.

Important

- Do not press any keys or perform mouse operations while POST is in progress.
- Powering on the server, after you installed or removed an optional PCI board or moved it to another slot, may display the message that indicates incorrect board configuration and suspend POST. In such a case, press **F1** to continue POST. Board configuration can be made using the utility described later.

1. POST runs automatically when the server is turned on. NEC logo appears on the screen as factory settings.
2. When **Password On Boot** is set to **Enabled** on the **Security** menu in the BIOS setup utility (SETUP), the logo is displayed, and then the password entry is displayed. If you enter the wrong password three times in a row, POST stops and you cannot proceed to the subsequent operation. In this case, turn off and on the server.

Important

Do not set a password until you install the OS.

3. If <Esc> key is pressed, the logo disappears and the details of POST are displayed.

Tips

To show the details of POST without pressing <ESC> key, set **Quiet Boot** to **Disabled** in the **Boot** menu of the BIOS settings.

4. POST displays several types of message. These messages let you know that the installed CPU or connected keyboard and mouse are detected.

5. After a while, the following message is displayed on the screen.

Press <F2> SETUP, <F3> Internal Flash Memory, <F4> ROM Utility, <F12> Network

You can call the functions below upon completion of POST by pressing the designated function key.

<F2> key: Run the SETUP. For information on the SETUP, see *Chapter 3 (2. System BIOS Setup)*.

<F3> key: Run EXPRESSBUILDER from Internal Flash Memory (optional). For information on EXPRESSBUILDER, see *Chapter 3 (4. EXPRESSBUILDER)*.

<F4> key: Run the offline tool. For information on the offline tool, see *Chapter 1 (9. Offline Tools) in "Maintenance Guide"*.

<F12> key: Boot from network.

Note

- If the optional Internal Flash Memory is not installed in the server, the <F3> key message is not displayed.
- Note that the server does not boot from Internal Flash Memory when a bootable CD/DVD-ROM is set on the drive.

6. If a controller which has its dedicated BIOS such as a SAS controller board is installed, a message that prompts you to start the dedicated utility to set each board is displayed.

Example: optional SAS controller

Press Ctrl-C to start LSI Corp Configuration Utility..

The utility starts by pressing <Ctrl> + <C> keys.

Example: optional RAID controller

Press <Ctrl> <H> for Web BIOS

The utility starts by pressing <Ctrl> + <H> keys.

Example: on-board RAID controller

Press <Ctrl> <M> to Run LSI Software RAID Configuration Utility

The utility starts by pressing <Ctrl> + <M> keys.

For details on the utility, refer to the manual supplied with each optional board.

Depending on the hardware configuration, the message "Press Any Key" might appear to prompt a key entry. This is a behavior of the BIOS of the optional board. Continue to operate after checking the manual of the optional board.

7. If you set a password at **SETUP** in the BIOS Setup utility, the password entry appears upon successful completion of POST.

Up to three password entries will be accepted. Three incorrect password entries disable the server to boot. In such a case, turn off the power and wait about ten seconds before turning on to boot the server.

Important

Do not set a password before OS is installed.

8. The OS starts when POST is completed.

1.1.2 POST error messages

If POST detects an error, an error message is displayed on the screen or beeps are sounded. Write down the error message for future use. For details, see "*Maintenance Guide*".

2. System BIOS Setup

This section describes how to configure Basic Input Output System (BIOS).

2.1 Overview

The BIOS Setup Utility (SETUP) is a utility to configure basic hardware settings. This utility is pre-installed in the server as standard and can run without bootable discs.

Usually, you do not need to change the parameters of the SETUP. **Use only when the case applies to any of cases described in Chapter 3 (2.4 Cases that Require Setting Changes).**

2.2 Starting SETUP Utility

Turn on the server and wait until the following message appears. See *Chapter 3 (1.1.1 POST sequence)* for details.

```
Press <F2> SETUP, <F3> Internal Flash Memory, <F4> ROM Utility, <F12> Network
```

When you press <F2> key during displaying the message or the NEC logo, SETUP runs and displays the **Main** menu upon completion of POST.

About password entry

The entry of the password appears after you set a password in SETUP.

```
Enter password [          ]
```

If you enter a wrong password three times, SETUP stops. Turn off the server and try again.

To exit SETUP after saving the parameters, choose **Save & Exit** and then **Save Changes and Exit**.

To exit SETUP without saving the parameters, select **Save & Exit** and then **Discard Changes and Exit**.

2.3 Usage of SETUP

This section explains how to use SETUP.

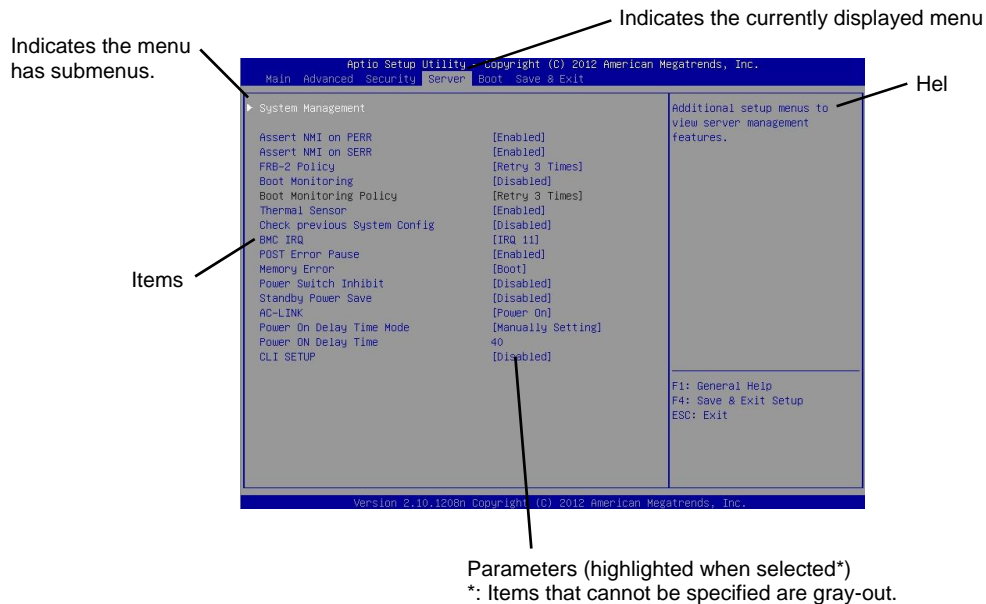

- Cursor keys (<↑>, <↓>)

Select an item displayed on the screen. If characters of an item are highlighted, that means the item is currently selected.
- Cursor keys (<←>, <→>)

Select menus including **Main**, **Advanced**, **Security**, **Server**, **Boot**, and **Save & Exit**.
- <→> key/<+> key

Change the parameter of the selected item. You cannot use this key when a menu which has ► on the left is selected.
- <Enter> key

Press this key to confirm the selected parameter.
- <Esc> key

Press this key to return the previous screen. If you choose **Yes** in the following message, SETUP closes without saving the changed parameters.

Quit without saving?	
[Yes]	No
- <F1> key

Press this key to display help information. Press <Esc> key to go back to the original screen.

<F2> key

Press this key to restore the parameters. If you choose **Yes** in the following message, the previous parameter(s) are restored.

Load Previous Values?
[Yes] No

 <F3> key

Press this key to load default settings. If you choose **Yes** in the following message, the default settings of SETUP are restored. **The default settings are different from the factory settings.** See Chapter 2 (1. System BIOS) in "Maintenance Guide" for details.

Load Setup Defaults?
[Yes] No

 <F4> key

Press this key to save parameters. If you choose **Yes** in the following message, the parameters you configured are saved and SETUP closes.

Save configuration and exit?
[Yes] No

2.4 Cases that Require Setting Changes

Specify parameters according to the following table when your system matches "Description". The list of SETUP parameters and factory settings are described in **Chapter 2 (1. System BIOS)** in "**Maintenance Guide**".

Category	Description	To be changed	Remark
Basic	Change date and time	Main → System Date Main → System Time	Configurable on OS
	On/Off NumLock on power ON	Boot → Bootup Numlock State	
	On/Off the function to display the NEC logo during POST	Boot → Quite Boot → Disabled	By pressing <Esc> key, prevent the display of the logo.
Optional board	When an optional board is installed, set to [Disabled] for Option ROM for all PCI devices except for the boot device.	Advanced → PCI Configuration → PCI Device Controller and Option ROM Settings → PCI Slot n Option ROM → Enabled	<i>n</i> is PCI slot number of the RAID Controller
		Advanced → PCI Configuration → PCI Device Controller and Option ROM Settings → LAN1 Option ROM Scan → Disabled	Option ROM on LAN1 must be disabled.
Memory	Configure the memory after the DIMM is added or exchanged.	Advanced → Memory Configuration → Memory Retest → Yes	After rebooting, the Memory Retest setting changes to No automatically.
Boot	Change the boot order of devices	Boot → Boot Option Priorities → Change the boot priority	
	Use remote power on feature (from modem)	Advanced → Advanced Chipset Configuration → Wake On Ring → Enabled	
	Use remote power on feature (from RTC alarm)	Advanced → Advanced Chipset Configuration → Wake On RTC Alarm → Enabled	
	Control from HW console terminal	Advanced → Serial Port Configuration → Change respective setting.	
Security	Set a password to restrict operation of SETUP.	Security → Administrator Password → Security → User password	After a password is set, the entry of password is displayed when SETUP is launched.
	Set a password to restrict booting.	Security → Password on Boot → Enabled	You can select this parameter after you set a password.

Category	Description	To be changed	Remark
UPS Powerlink	When the server is supplied with power from UPS, always turn on the power.	Server → Power Control Configuration → AC-LINK → Power On	
	If the server is turned off by using POWER switch, leave it OFF even when UPS supplies power.	Server → Power Control Configuration → AC-LINK → Last State	
	Keep the power OFF even when UPS supplies power.	Server → Power Control Configuration → AC-LINK → Stay off	

3. EXPRESSSCOPE ENGINE 3

3.1 Overview

EXPRESSSCOPE Engine 3 provides useful features by using Baseboard Management Controller (BMC).

EXPRESSSCOPE Engine 3 monitors the power unit, cooling fans, temperature, and voltage of the server. If the management LAN connector is connected to the network, you can remotely perform the following features by using a web browser or SSH client.

- Managing the server
- Remotely controlling the keyboard, video, and mouse (KVM)*
- Remotely accessing a CD/DVD/floppy disk/ISO image/USB flash drive*

* To use this feature, the optional license for remote management (N8115-04) is required.

To enable this feature, a USB mass storage device, such as Remote FD, Remote CD/DVD, Remote USB flash drive or Virtual Flash is virtually connected.

About N8115-04 Remove KVM and Media License

More than one removable drives other than the actual drives are displayed on the operating system of the server. These added removable drives are the virtual removable drives reserved for the remote media feature of EXPRESSSCOPE Engine 3 (*1).

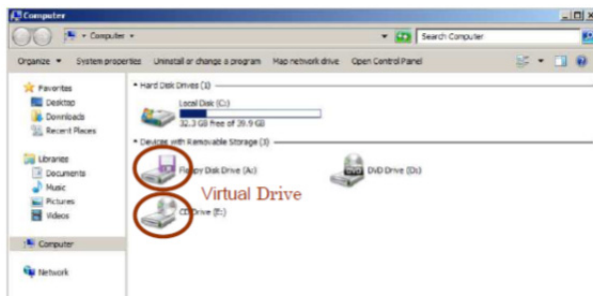

Fig. 1 Example of Windows Server 2008 R2 Computer Folder (*2)

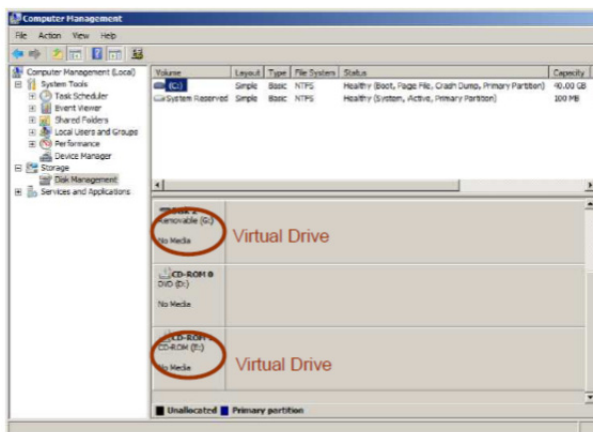

Fig. 2 Example of Windows Server 2008 R2 Server Manager (*2)

*1 This feature enables you to use FD/CD/DVD drives, ISO images or USB flash drives on "PC for Management" as virtual drives that are connected to the server.

*2 The number of drives and the drive character are different depending on hardware configurations.

3.2 EXPRESSSCOPE ENGINE 3 Network Configuration

To use EXPRESSSCOPE Engine 3 through the network, follow the steps below.

1. Turn on the server and wait until the following message appears on the lower left of the screen. See *Chapter 3 (1.1.1 POST sequence)* for details.

Press <F2> SETUP, <F3> Internal Flash Memory, <F4> ROM Utility, <F12> Network

2. When you press <F4> key during displaying the message or the NEC logo, ROM utility starts upon completion of POST.
3. The keyboard selection menu appears. Choose your keyboard type.
4. On the Off-line TOOL MENU, choose **BMC Configuration**, **BMC Configuration**, **Network**, and then **Property**.

```
Off-line TOOL MENU
Off-line TOOL MENU
Maintenance Utility
BMC Configuration
BMC Configuration Initialization
Exit

These utilities are for maintenance and configuration.

- System information is displayed, managed,
  and set in "Maintenance Utility".
- BMC information is displayed and set in "BMC Configuration".
- All of BMC Configuration parameters are restored to the default
  in "BMC Configuration Initialization".
- Exits the Off-line TOOL and resets the system in "Exit".
```

5. In the **DHCP** of the Property screen, specify **Enable** or configure **IP Address/Subnet Mask**.

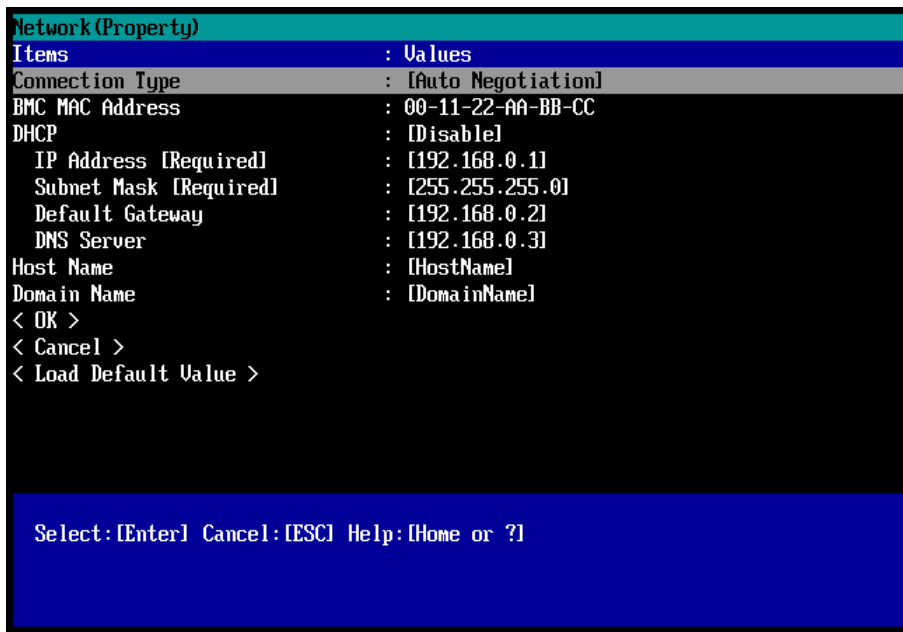

Tips

If **Shared BMC LAN** is enabled, Web feature, remote media/KVM feature, or command line interface feature may be interrupted. In this case, wait for a while, and connect with network again.

6. Connect the LAN cable to the management LAN connector in order to connect to the network. Access EXPRESSSCOPE Engine 3 by using a web browser from "PC for Management" with the settings specified by step 5.

4. EXPRESSBUILDER

EXPRESSBUILDER helps you to install Windows or maintain the server.

4.1 Features of EXPRESSBUILDER

EXPRESSBUILDER provides the following features.

Features	Descriptions
Setup (Windows reinstallation)	Installs Windows on your server. Easily completes the process from RAID configuration to installation of applications. To use this feature, choose OS installation in Boot Selection Menu.
Bundled software*	Stores various bundled software, such as NEC ESMPRO Agent.
Maintenance	Diagnoses your server system. To use this feature, choose Tool menu in Boot Selection Menu.
Instruction manuals*	Stores various documents, such as " <i>User's Guide</i> ", " <i>Installation Guide</i> " and " <i>Maintenance Guide</i> ".

*Documents and some software components are not stored in N8115-14 Internal Flash Memory (option).

4.2 Usage of EXPRESSBUILDER

If you want to install Windows, start EXPRESSBUILDER by using the following ways.

EXPRESSBUILDER disc:

Insert the disc into the server and either turn on the server or restart the server by pressing <Ctrl> + <Alt> + <Delete> keys. EXPRESSBUILDER starts from the disc.

If you want to install any bundled software or see documents, insert the disc into a computer on which Windows is running. The Autorun menu appears automatically.

N8115-14 Internal Flash Memory (optional):

Confirm that the EXPRESSBUILDER disc or other bootable disc is not inserted. Press <F3> key when the following message appears on POST screen.

Press <F2> SETUP, <F3> Internal Flash Memory, <F4> ROM Utility, <F12> Network

5. Installing Software Components

Continue to install the operating system and other bundled software.

See the instructions below.

- *Installation Guide (Windows)*

6. Turning off the Server

Turn off the server by using the following procedure. When the power cord of the server is connected to a UPS, refer to the documentation supplied with the UPS or the documentation for the application controlling the UPS.

1. Shut down the OS.
2. If the server does not automatically power off, press POWER Switch at the front of the server.
Confirm that POWER LED is OFF.
3. Turn off peripheral devices.

NEC Express5800 Series Express5800/T110g-S

4

Appendix

1. Specifications
2. Interrupt Lines

I. Specifications

I.I Air Cooling System

Product name		Express5800/T110g-S, EXP285A	
		N8100-2195F	
CPU	Type	Intel® Pentium® processor G3240	Intel® Core™ i3-4350 processor
	Clock/cache	3.10 GHz/3 MB	3.60 GHz/4 MB
	Standard / (maximum)	Not pre-installed / (1)	
Chipset		Intel® C224 Chipset	
Memory	Standard	Not pre-installed	
	Maximum	32 GB (8 GB x 4)	
	Expansion unit	DDR3L-1600 SDRAM DIMM (unbuffered) x 1	
	Memory module	ECC DDR3L-1600 SD-RAM DIMM with 2Way Interleave support	
Graphics		Integrated in BMC (more than 32 MB)	
Auxiliary storage	Hard Disk Drive (standard)	Not pre-installed	
	Hard Disk Drive (maximum)	3.5-inch HDD cage (N8154-65F) installed: 8 TB (2 x 4 TB) 2.5-inch HDD cage (N8154-71F/-72F) installed: SATA 6 TB (6 x 1 TB), SAS 7.2 TB (6 x 1.2 TB), SAS SSD 2.4 TB (6 x 400 GB) 3.5-inch/2.5-inch HDD cage (N8154-65F/-72F) installed: SATA 10 TB (2 x 4 TB + 2 x 1 TB), SATA+SAS 10.4 TB (2 x 4 TB SATA + 2 x 1.2 TB SAS)	
	RAID	SATA 6 Gb/s : RAID 0/1/10(standard), RAID 5/6/50/60 (optional) SAS 6 Gb/s : RAID 0/1/5/6/10/50/60 (optional)	
	Optical disk drive	Selectable: DVD-ROM drive or DVD SuperMULTI drive	
Expansion bay	Disk bay	3.5-inch Hard Disk Drive x 2 + 2.5-inch Hard Disk Drive x 2 (optional) 2.5-inch Hard Disk Drive x 4 + 2.5-inch Hard Disk Drive x 2 (optional)	
	Backup device	1 slot	
Expansion slot (PCI)		1x PCI Express 3.0 (x16 lane, x16 socket) 1x PCI Express 2.0 (x4 lane, x8 socket) 2x PCI Express 2.0 (x1 lane, x8 socket)	
External interface	USB3.0	Front: 1 port; rear: 2 ports; internal: 1 port	
	USB2.0	Front: 1 port; rear: 2 ports; internal: 1 port	
	Serial	1 port (D-sub 9-pin)	
	Network	2-port 1000Base-T, 100Base-TS/10Base-T (RJ-45) Management LAN connector (RJ-45)	
	Display	MINI D-sub 15-pin (1 port)	
External dimensions		98.0 mm (width) x 386.5 mm (depth) x 341.0 mm (height) (not including vent holes cover, stabilizer, protrusions) 200.0 mm (width) x 393.7 mm (depth) x 347.1 mm (height) (vent holes cover, stabilizer, protrusions included)	
Mass (maximum)		8 kg (11 kg)	
Power supply		1 x 250 W 80 PLUS® Platinum (bipolar grounded outlet) (hot-plug not available) 100/200 VAC ± 10%, 50/60 Hz ± 3 Hz	
Power rating		380 W	
Environmental conditions	When running	Temperature: 10 to 40°C; Humidity: 20 to 80% (and no condensation)	
	When in storage	Temperature: -10 to 55°C; Humidity: 20 to 80% (and no condensation)	
Bundled OS		None	
Supported OSs		Microsoft® Windows Server® 2008 Standard (RTM, SP2 or later) Microsoft® Windows Server® 2008 Enterprise (RTM, SP2 or later) Microsoft® Windows Server® 2008 R2 Standard Microsoft® Windows Server® 2008 R2 Enterprise Microsoft® Windows Server® 2012 Standard Microsoft® Windows Server® 2012 Datacenter Microsoft® Windows Server® 2012 R2 Standard Microsoft® Windows Server® 2012 R2 Datacenter Microsoft® Windows Server® 2012 R2 Essentials Microsoft® Windows Server® 2012 R2 Foundation	
Included parts		104 keyboard, two-button mouse with scroll wheel, rubber feet, EXPRESSBUILDER DVD, Getting Started, screws for device, Power cord	

* Can be optionally expanded to two ports.

Product name		Express5800/T110g-S, EXP285A		
		N8100-2195F		
CPU	Type	Intel® Xeon® processor E3-1220 v3	Intel® Xeon® processor E3-1240L v3	Intel® Xeon® processor E3-1275L v3
	Clock/cache	3.10 GHz/8 MB	2 GHz/8 MB	2.70 GHz/8 MB
	Standard / (maximum)	Not pre-installed / (1)		
Chipset		Intel® C224 Chipset		
Memory	Standard	Not pre-installed		
	Maximum	32 GB (8 GB x 4)		
	Expansion unit	DDR3L-1600 SDRAM DIMM (unbuffered) x 1		
	Memory module	ECC DDR3L-1600 SD-RAM DIMM with 2Way Interleave support		
Graphics		Integrated in BMC (more than 32 MB)		
Auxiliary storage	Hard Disk Drive (standard)	Not pre-installed		
	Hard Disk Drive (maximum)	3.5-inch HDD cage (N8154-65F) installed: 8 TB (2 x 4 TB) 2.5-inch HDD cage (N8154-71F/-72F) installed: SATA 6 TB (6 x 1 TB), SAS 7.2 TB (6 x 1.2 TB), SAS SSD 2.4 TB (6 x 400 GB) 3.5-inch/2.5-inch HDD cage (N8154-65F/-72F) installed: SATA 10 TB (2 x 4 TB + 2 x 1 TB), SATA+SAS 10.4 TB (2 x 4 TB SATA + 2 x 1.2 TB SAS)		
	RAID	SATA 6 Gb/s : RAID 0/1/10(standard), RAID 5/6/50/60 (optional) SAS 6 Gb/s : RAID 0/1/5/6/10/50/60 (optional)		
	Optical disk drive	Selectable: DVD-ROM drive or DVD SuperMULTI drive		
Expansion bay	Disk bay	3.5-inch Hard Disk Drive x 2 + 2.5-inch Hard Disk Drive x 2 (optional) 2.5-inch Hard Disk Drive x 4 + 2.5-inch Hard Disk Drive x 2 (optional)		
	Backup device	1 slot		
Expansion slot (PCI)		1x PCI Express 3.0 (x16 lane, x16 socket) 1x PCI Express 2.0 (x4 lane, x8 socket) 2x PCI Express 2.0 (x1 lane, x8 socket)		
External interface	USB3.0	Front: 1 port; rear: 2 ports; internal: 1 port		
	USB2.0	Front: 1 port; rear: 2 ports; internal: 1 port		
	Serial	1 port (D-sub 9-pin)*		
	Network	2-port 1000Base-T, 100Base-TS/10Base-T (RJ-45) Management LAN connector (RJ-45)		
	Display	MINI D-sub 15-pin (1 port)		
External dimensions		98.0 mm (width) x 386.5 mm (depth) x 341.0 mm (height) (not including vent holes cover, stabilizer, protrusions) 200.0 mm (width) x 393.7 mm (depth) x 347.1 mm (height) (vent holes cover, stabilizer, protrusions included)		
Mass (maximum)		8 kg (11 kg)		
Power supply		1 x 250 W 80 PLUS® Platinum (bipolar grounded outlet) (hot-plug not available) 100/200 VAC ± 10%, 50/60 Hz ± 3 Hz		
Power rating		380 W		
Environmental conditions	When running	Temperature: 10 to 40°C; Humidity: 20 to 80% (and no condensation)		
	When in storage	Temperature: -10 to 55°C; Humidity: 20 to 80% (and no condensation)		
Bundled OS		None		
Supported OSs		Microsoft® Windows Server® 2008 Standard (RTM, SP2 or later) Microsoft® Windows Server® 2008 Enterprise (RTM, SP2 or later) Microsoft® Windows Server® 2008 R2 Standard Microsoft® Windows Server® 2008 R2 Enterprise Microsoft® Windows Server® 2012 Standard Microsoft® Windows Server® 2012 Datacenter Microsoft® Windows Server® 2012 R2 Standard Microsoft® Windows Server® 2012 R2 Datacenter Microsoft® Windows Server® 2012 R2 Essentials Microsoft® Windows Server® 2012 R2 Foundation		
Included parts		104 keyboard, two-button mouse with scroll wheel, rubber feet, EXPRESSBUILDER DVD, Getting Started, screws for device, Power cord		

* Can be optionally expanded to two ports.

Product name		Express5800/T110g-S, EXP285A	
		N8100-2195F	
CPU	Type	Intel® Xeon® processor E3-1231 v3	Intel® Xeon® processor E3-1271 v3
	Clock/cache	3.40 GHz/8 MB	3.60 GHz/8 MB
	Standard / (maximum)	Not pre-installed / (1)	
Chipset		Intel® C224 Chipset	
Memory	Standard	Not pre-installed	
	Maximum	32 GB (8 GB x 4)	
	Expansion unit	DDR3L-1600 SDRAM DIMM (unbuffered) x 1	
	Memory module	ECC DDR3L-1600 SD-RAM DIMM with 2Way Interleave support	
Graphics		Integrated in BMC (more than 32 MB)	
Auxiliary storage	Hard Disk Drive (standard)	Not pre-installed	
	Hard Disk Drive (maximum)	3.5-inch HDD cage (N8154-65F) installed: 8 TB (2 x 4 TB) 2.5-inch HDD cage (N8154-71F/-72F) installed: SATA 6 TB (6 x 1 TB), SAS 7.2 TB (6 x 1.2 TB), SAS SSD 2.4 TB (6 x 400 GB) 3.5-inch/2.5-inch HDD cage (N8154-65F/-72F) installed: SATA 10 TB (2 x 4 TB + 2 x 1 TB), SATA+SAS 10.4 TB (2 x 4 TB SATA + 2 x 1.2 TB SAS)	
	RAID	SATA 6 Gb/s : RAID 0/1/10(standard), RAID 5/6/50/60 (optional) SAS 6 Gb/s : RAID 0/1/5/6/10/50/60 (optional)	
	Optical disk drive	Selectable: DVD-ROM drive or DVD SuperMULTI drive	
Expansion bay	Disk bay	3.5-inch Hard Disk Drive x 2 + 2.5-inch Hard Disk Drive x 2 (optional) 2.5-inch Hard Disk Drive x 4 + 2.5-inch Hard Disk Drive x 2 (optional)	
	Backup device	1 slot	
Expansion slot (PCI)		1x PCI Express 3.0 (x16 lane, x16 socket) 1x PCI Express 2.0 (x4 lane, x8 socket) 2x PCI Express 2.0 (x1 lane, x8 socket)	
External interface	USB3.0	Front: 1 port; rear: 2 ports; internal: 1 port	
	USB2.0	Front: 1 port; rear: 2 ports; internal: 1 port	
	Serial	1 port (D-sub 9-pin)	
	Network	2-port 1000Base-T, 100Base-TS/10Base-T (RJ-45) Management LAN connector (RJ-45)	
	Display	MINI D-sub 15-pin (1 port)	
External dimensions		98.0 mm (width) x 386.5 mm (depth) x 341.0 mm (height) (not including vent holes cover, stabilizer, protrusions) 200.0 mm (width) x 393.7 mm (depth) x 347.1 mm (height) (vent holes cover, stabilizer, protrusions included)	
Mass (maximum)		8 kg (11 kg)	
Power supply		1 x 250 W 80 PLUS® Platinum (bipolar grounded outlet) (hot-plug not available) 100/200 VAC ± 10%, 50/60 Hz ± 3 Hz	
Power rating		380 W	
Environmental conditions	When running	Temperature: 10 to 40°C; Humidity: 20 to 80% (and no condensation)	
	When in storage	Temperature: -10 to 55°C; Humidity: 20 to 80% (and no condensation)	
Bundled OS		None	
Supported OSs		Microsoft® Windows Server® 2008 Standard (RTM, SP2 or later) Microsoft® Windows Server® 2008 Enterprise (RTM, SP2 or later) Microsoft® Windows Server® 2008 R2 Standard Microsoft® Windows Server® 2008 R2 Enterprise Microsoft® Windows Server® 2012 Standard Microsoft® Windows Server® 2012 Datacenter Microsoft® Windows Server® 2012 R2 Standard Microsoft® Windows Server® 2012 R2 Datacenter Microsoft® Windows Server® 2012 R2 Essentials Microsoft® Windows Server® 2012 R2 Foundation	
Included parts		104 keyboard, two-button mouse with scroll wheel, rubber feet, EXPRESSBUILDER DVD, Getting Started, screws for device, Power cord	

* Can be optionally expanded to two ports.

1.2 Liquid Cooling System

Product name		Express5800/T110g-S, EXP285A			
		N8100-2196F			
CPU	Type	Intel® Core™ i3-4350 processor	Intel® Xeon® processor E3-1220 v3	Intel® Xeon® processor E3-1231 v3	Intel® Xeon® processor E3-1275L v3
	Clock/cache	3.60 GHz/4 MB	3.10 GHz/8 MB	3.40 GHz/8 MB	2.70 GHz/8 MB
	Standard / (maximum)	Not pre-installed / (1)			
Chipset		Intel® C224 Chipset			
Memory	Standard	Not pre-installed			
	Maximum	32 GB (8 GB x 4)			
	Expansion unit	DDR3L-1600 SDRAM DIMM (unbuffered) x 1			
	Memory module	ECC DDR3L-1600 SD-RAM DIMM with 2Way Interleave support			
Graphics		Integrated in BMC (more than 32 MB)			
Auxiliary storage	Hard Disk Drive (standard)	Not pre-installed			
	Hard Disk Drive (maximum)	3.5-inch HDD cage (N8154-65F) installed: 8 TB (2 x 4 TB) 2.5-inch HDD cage (N8154-71F/-72F) installed: SATA 6 TB (6 x 1 TB), SAS 7.2 TB (6 x 1.2 TB), SAS SSD 2.4 TB (6 x 400 GB) 3.5-inch/2.5-inch HDD cage (N8154-65F/-72F) installed: SATA 10 TB (2 x 4 TB + 2x 1 TB), SATA+SAS 10.4 TB (2 x 4 TB SATA + 2 x 1.2 TB SAS)			
	RAID	SATA 6 Gb/s : RAID 0/1/10(standard), RAID 5/6/50/60 (optional) SAS 6 Gb/s : RAID 0/1/5/6/10/50/60 (optional)			
	Optical disk drive	Selectable: DVD-ROM drive or DVD SuperMULTI drive			
Expansion bay	Disk bay	3.5-inch Hard Disk Drive x 2 + 2.5-inch Hard Disk Drive x 2 (optional) 2.5-inch Hard Disk Drive x 4 + 2.5-inch Hard Disk Drive x 2 (optional)			
	Backup device	1 slot (used exclusively with 2.5-inch HDD cage (N8154-72F))			
Expansion slot (PCI)		1x PCI Express 3.0 (x16 lane, x16 socket) 1x PCI Express 2.0 (x4 lane, x8 socket) 2x PCI Express 2.0 (x1 lane, x8 socket)			
External interface	USB3.0	Front: 1 port; rear: 2 ports; internal: 1 port			
	USB2.0	Front: 1 port; rear: 2 ports; internal: 1 port			
	Serial	1 port (D-sub 9-pin)*			
	Network	2-port 1000Base-T, 100Base-TS/10Base-T (RJ-45) Management LAN connector (RJ-45)			
	Display	MINI D-sub 15-pin (1 port)			
External dimensions		98.0 mm (width) x 386.5 mm (depth) x 341.0 mm (height) (not including vent holes cover, stabilizer, protrusions) 200.0 mm (width) x 393.7 mm (depth) x 347.1 mm (height) (vent holes cover, stabilizer, protrusions included)			
Mass (maximum)		8 kg (11 kg)			
Power supply		1x 250 W 80 PLUS® Platinum (bipolar grounded outlet) (hot-plug not available) 100/200 VAC ± 10%, 50/60 Hz ± 3 Hz			
Power rating		380 W			
Environmental conditions	When running	Temperature: 10 to 40°C; Humidity: 20 to 80% (and no condensation)			
	When in storage	Temperature: -10 to 55°C; Humidity: 20 to 80% (and no condensation)			
Bundled OS		None			
Supported OSs		Microsoft® Windows Server® 2008 Standard (RTM, SP2 or later) Microsoft® Windows Server® 2008 Enterprise (RTM, SP2 or later) Microsoft® Windows Server® 2008 R2 Standard Microsoft® Windows Server® 2008 R2 Enterprise Microsoft® Windows Server® 2012 Standard Microsoft® Windows Server® 2012 Datacenter Microsoft® Windows Server® 2012 R2 Standard Microsoft® Windows Server® 2012 R2 Datacenter Microsoft® Windows Server® 2012 R2 Essentials Microsoft® Windows Server® 2012 R2 Foundation			
Included parts		104 keyboard, two-button mouse with scroll wheel, rubber feet, EXPRESSBUILDER DVD, Getting Started, screws for device, Power cord			

* Can be optionally expanded to two ports.

2. Interrupt Lines

Interrupt lines are assigned as factory settings as shown below. Use this table as a reference when you add optional devices.

- **Interrupt lines**

As factory settings, interrupt lines are assigned as follows.

IRQ	Peripheral Device (Controller)	IRQ	Peripheral Device (Controller)
0	System timer	8	Real-time clock
1	–	9	Microsoft ACPI-Compliant System
2	Cascade connection	10	PCI
3	COM 2 serial port	11	PCI
4	COM 1 serial port	12	–
5	PCI	13	Arithmetic operation processor
6	–	14	–
7	–	15	–